

**Watson & Chalin Pivot Bolt Replacement
VHD**

RECALL INFORMATION

(June, 2021)

Watson & Chalin Manufacturing, Inc. ("W&C") has decided that a defect which relates to motor vehicle safety exists in a limited number of SL2065 20,000-pound rated capacity steerable auxiliary lift axle suspension systems. These SL2065 suspension systems were manufactured between November 13, 2019 and April 30, 2020.

These suspensions may be equipped with lower rear pivot cap screws that are not long enough to sufficiently engage the locking feature of the corresponding nuts.

Volvo Trucks has not received any complaints or reports of vehicle crashes because of this non-compliance.

To ensure that these vehicles meet Volvo's stringent quality requirements. Replacement of the lower rear pivot fasteners is required. These parts will need to be obtained directly from Watson & Chalin.

VEHICLES AFFECTED

One Volvo North America vehicle manufactured on October 30, 2002.

VEHICLE QUANTITY

There is 1 vehicle affected by this recall (1 U.S.).

Parts Instructions

Parts need to be ordered direct from Watson & Chalin by calling 972-838-1623 or emailing warranty@watsonsuspensions.com . When contacting Watson & Chalin for parts the following information will be needed:

VIN	
Lift Axle Model Number	
Lift Axle Serial Number	
Build Date	
In Service Date	
Current Mileage	
Ship to Address	
Contact Name	

Part Number	Part Names	Quantity
SRK2065WAR-001	Lower Rear Pivot Fastener Repair Kit	1

Repair Instructions

1. Verify all required parts were received in the service repair kit.
2. Verify all required parts are free from damage that would impair function.
3. Verify that the threads of the fasteners are clean and dry.
4. Lay out all required replacement parts such that they can be easily located during reassembly.
5. Verify all required tools are available.
6. Verify all required tools are free from damage that would impair function.
7. Lay out all required tools such that they can be easily located.
8. Park the vehicle on a flat, level surface.
9. Engage the parking brake so that the vehicle may not roll.
10. Chock the vehicle's wheels so that the vehicle may not roll.
11. Verify the vehicle will be properly restrained from movement and safe to work on.
12. Lower the auxiliary lift axle so that the tires are in contact with the ground.
13. Depressurize the auxiliary lift axle air system. De-pressurize the entire vehicle air system if required.
14. Verify system air pressure cannot be restored inadvertently while working on the vehicle.
15. Follow any additional vehicle manufacturer and/or dealership safety procedures and precautions to ensure the vehicle can be safely repaired and maintained.
16. Support the auxiliary lift axle with adjustable supports such as jacks, stands, or straps so that it does not roll or move when the control arm fasteners are removed.

17. From this point forward, work on only one side of the vehicle at a time.

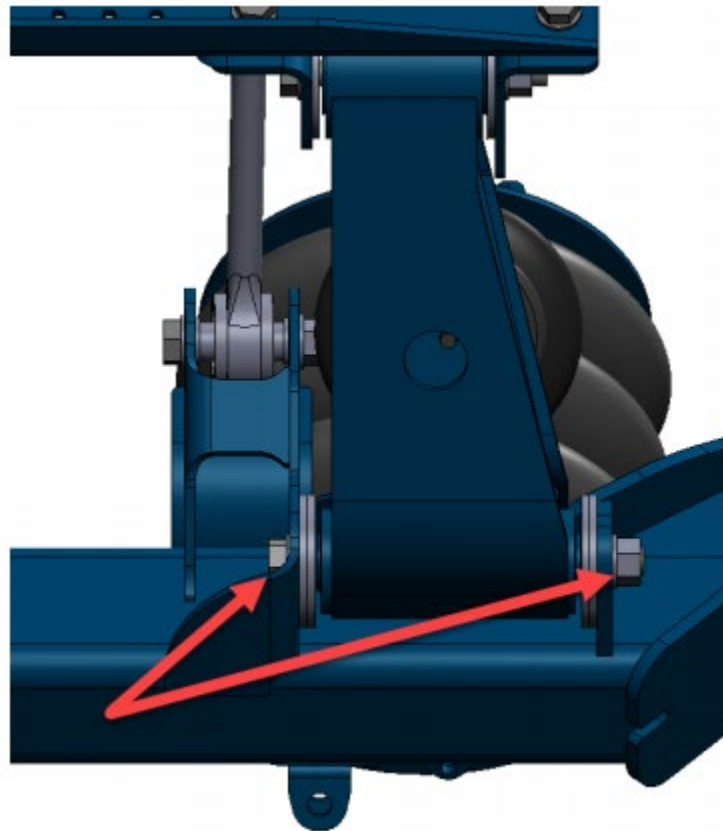

18. Remove the axle-side fasteners:

a. Make note of the lower control arm spacer washer locations. These are the large diameter washers

inside of the axle flanges. If required, mark the locations or take photographs to reference during re-installation. NOTE THAT WASHER LOCATIONS MAY DIFFER FROM THE ABOVE PICTURE. Spacer

washers may be left in and reused if they are free from damage.

b. Use 1-5/16-inch wrenches and/or sockets to remove the nuts.

c. If required, use a grinder and cutoff wheel to remove stuck fasteners. Take care not to damage the axle flange, axle tube, or any other vehicle components when using the grinder.

d. Secure the control arm with a jack stand, so it does not fall, and knock out the cap screw using punches and a hammer. USE CAUTION, AS CONTROL ARM MAY SHIFT WHEN THE FASTENER IS REMOVED.

19. Install the replacement fasteners:

- a. If required, place a floor jack or other lifting device under the lower control arm, then raise it into the axle.
- b. Install the lower control arm spacer washers. An alignment or center punch inserted from the outboard side may be used to hold them in place until the cap screw is inserted. For correct washer locations, reference notes taken in Step 18a.
- c. Install the lower control arm pivot cap screw, washers, and nut, but do not tighten.
- d. Use 1-5/16-inch wrenches and / or sockets to snug the lower pivot fastener. Confirm fastener is fully engaged with the joint.
- e. Secure the heads of the cap screws with a combination wrench and tighten the nuts to 400 lb-ft torque. DO NOT TORQUE FROM HEAD OF CAP SCREW.

20. Repeat steps 18 and 19 for the opposite side of the vehicle.

21. Re-pressurize the vehicle's air system.

22. Cycle the auxiliary suspension.

23. Return vehicle to lot.

NOTE: If any of the existing lower rear pivot cap screws currently equipped on suspensions are loose or damaged, the vehicle should not be further operated until the replacement cap screws are installed.

REIMBURSEMENT

This repair is covered by an authorized Safety recall. Reimbursement is obtained through the normal claim handling process.	
	UCHP Reimbursement
Claim Type (used only when uploading from the Dealer Business System)	40
Recall Status	
Vehicle repaired per instructions	1-Modified per instructions
Labor Codes	
Primary Labor Code: 1720-16-09-01 General Campaign. 0.1 x 8	0.8
Causal Part	FAA088120000A00
Authorization Number	C6629

Note: Dealers are to perform Safety Recall Campaign on all subject vehicles at no charge to the vehicle owner regardless of mileage, age of vehicle or ownership (original purchaser or subsequent purchasers). Whenever vehicles are subject to a Safety Recall are brought to your dealership for service, or taken into your dealership vehicle inventory, it is strongly recommended that every effort be made to perform the recall correction before the vehicle is sold or released to the owner.