

Safety Recall

Code: 20Z8



REVISION

Subject	Fuel Pump Flange
Release Date	July 03, 2017
Revision Summary	Repair available for Audi Q5.
Affected Vehicles	U.S.A. & CANADA: Certain 2013-2017 MY Audi Q5 and 2013-2015 Audi Q7 <i>Check Campaigns/Actions screen in Elsa on the day of repair to verify that a VIN qualifies for repair under this action. Elsa is the <u>only</u> valid campaign inquiry & verification source.</i> <ul style="list-style-type: none">✓ Campaign status must show "open."✓ If Elsa shows other open action(s), inform your customer so that the work can also be completed at the same time the vehicle is in the workshop for this campaign.
Problem Description	On certain vehicles, the fuel pump flange may develop fine cracks or fissures, which could result in a fuel leak. Leaking fuel, in the presence of an ignition source, could lead to a fire causing injury and/or damage to property.
Corrective Action	If cracks, leaks, and/or yellow discoloration are present, the fuel pump flange will be replaced and a protective film installed onto the fuel pump flange. If no cracks, leaks, and/or yellow discoloration are present, a protective film will be installed onto the fuel pump flange.
Precautions	If a fuel smell is detected in the vehicle, customers are advised to immediately contact the nearest authorized Audi dealer in order to have the vehicle inspected.
Parts Information	Parts were allocated prior to owner notification. If allocated parts have been used and your dealership is at the weekly Upper Order Limit, please submit the backordered sales document number to upperorderlimits@audi.com to have additional parts released. Part numbers 8R0919679D and 8R0919679E will not be allocated and will be placed on Technical Service Block. If these parts are needed to repair a vehicle requiring a fuel pump flange, follow the instructions in the bulletin to have the part released.
Code Visibility	On June 26, 2017, affected vehicles were listed on the Inventory Vehicle Open Campaign Action report under My Dealership Reports (found on www.accessaudi.com & OMD Web). A list was not posted for dealers who did not have any affected vehicles. On June 26, 2017, this campaign code showed open on affected vehicles in Elsa. On June 26, 2017, affected vehicles were identified with this campaign code in the VIN Lookup tool at www.audiusa.com and on the NHTSA VIN lookup tool at www.safercar.gov .
Owner Notification	Owner notification took place in July 2017. Owner letter examples are included in this bulletin for your reference.
Additional Information	Please alert everyone in your dealership about this action, including Sales, Service, Parts and Accounting personnel. Contact Warranty if you have any questions. IMPORTANT REMINDER ON VEHICLES AFFECTED BY SAFETY & COMPLIANCE RECALLS <u>New Vehicles in Dealer Inventory:</u> It is a violation of Federal law for a dealer to deliver a new motor vehicle or any new or used item of motor vehicle equipment (including a tire) covered by this notification under a sale or lease until the defect or noncompliance is remedied. By law, dealers must correct, prior to delivery for sale or lease, any vehicle that fails to comply

with an applicable Federal Motor Vehicle Safety Standard or that contains a defect relating to motor vehicle safety.

Pre-Owned Vehicles in Dealer Inventory: Dealers should not deliver any pre-owned vehicles in their inventory which are involved in a safety or compliance recall until the defect has been remedied.

Dealers must ensure that every affected inventory vehicle has this campaign completed before delivery to consumers.

Claim Entry Instructions

After campaign has been completed, enter claim as soon as possible to help prevent work from being duplicated elsewhere. Attach the Elsa screen print showing action open on the day of repair to the repair order.

If customer refused campaign work:

- ✓ U.S. dealers: Submit the request through Audi Warranty Online under the Campaigns/Update option.
- ✓ Canada dealers: Fax repair order to Warranty at (905) 428-4811.

Service Number	20Z8																														
Damage Code	0099																														
Parts Vendor Code	002																														
Claim Type	Sold vehicle: 7 10 Unsold vehicle: 7 90																														
Causal Indicator	Mark protective film* as causal																														
Vehicle Wash/Loaner	Do not claim wash/loaner under this action																														
Criteria I.D.	4L (Audi Q7)																														
<p>-if cracks, leaks, and/or yellow discoloration <u>ARE NOT</u> found-</p> <p>Check fuel filter flange. Cracks, leaks, and/or yellow discoloration <u>NOT</u> found, install protective film, and reinstall seat frame.</p> <p>Labor operation: 7249 19 99 60 T.U.</p> <table border="1"> <thead> <tr> <th><u>Quantity</u></th> <th><u>Part Number</u></th> <th><u>Part Description</u></th> </tr> </thead> <tbody> <tr> <td>1.00</td> <td>8R0863385</td> <td>Protective Film*</td> </tr> <tr> <td>4.00</td> <td>N 90965001</td> <td>Socket head bolt</td> </tr> <tr> <td>1.00</td> <td>N 91040702</td> <td>Socket head bolt</td> </tr> </tbody> </table> <p>-OR if cracks, leaks, and/or yellow discoloration <u>ARE</u> found-</p> <p>Check fuel filter flange. Cracks, leaks, and/or yellow discoloration <u>ARE</u> found. Replace fuel filter flange, install protective film, and reinstall seat frame.</p> <p>Labor operation: 2031 19 99 150 T.U.</p> <table border="1"> <thead> <tr> <th><u>Quantity</u></th> <th><u>Part Number</u></th> <th><u>Part Description</u></th> </tr> </thead> <tbody> <tr> <td>4.00</td> <td>N 90965001</td> <td>Socket head bolt</td> </tr> <tr> <td>1.00</td> <td>N 91040702</td> <td>Socket head bolt</td> </tr> <tr> <td>1.00</td> <td>7L8919679</td> <td>Fuel filter with flange</td> </tr> <tr> <td>1.00</td> <td>1J0919133B</td> <td>Seal Ring</td> </tr> <tr> <td>1.00</td> <td>8R0863385</td> <td>Protective Film*</td> </tr> </tbody> </table> <p>-Continue to next page-</p>		<u>Quantity</u>	<u>Part Number</u>	<u>Part Description</u>	1.00	8R0863385	Protective Film*	4.00	N 90965001	Socket head bolt	1.00	N 91040702	Socket head bolt	<u>Quantity</u>	<u>Part Number</u>	<u>Part Description</u>	4.00	N 90965001	Socket head bolt	1.00	N 91040702	Socket head bolt	1.00	7L8919679	Fuel filter with flange	1.00	1J0919133B	Seal Ring	1.00	8R0863385	Protective Film*
<u>Quantity</u>	<u>Part Number</u>	<u>Part Description</u>																													
1.00	8R0863385	Protective Film*																													
4.00	N 90965001	Socket head bolt																													
1.00	N 91040702	Socket head bolt																													
<u>Quantity</u>	<u>Part Number</u>	<u>Part Description</u>																													
4.00	N 90965001	Socket head bolt																													
1.00	N 91040702	Socket head bolt																													
1.00	7L8919679	Fuel filter with flange																													
1.00	1J0919133B	Seal Ring																													
1.00	8R0863385	Protective Film*																													

The repair information in this document is intended for use only by skilled technicians who have the proper tools, equipment and training to correctly and safely maintain your vehicle. These procedures are not intended to be attempted by "do-it-yourselfers," and you should not assume this document applies to your vehicle, or that your vehicle has the condition described. To determine whether this information applies, contact an authorized Audi dealer. ©2017 Audi of America, Inc. and Audi Canada. All Rights Reserved.

-and ONLY if damage to wire harness seal is present-

Repair wire harness connector.

Labor operation: 2031 20 99 up to 100 T.U.

<u>Quantity</u>	<u>Part Number</u>	<u>Part Description</u>
As Required	Per ETKA	Connector
As Required	Per ETKA	Wires
As Required	Per ETKA	Connector Seal

Criteria I.D.

8R (Audi Q5)

-if cracks, leaks, and/or yellow discoloration ARE NOT found-

Check fuel filter flange. Cracks, leaks, and/or yellow discoloration NOT found, install protective film, and reinstall seat frame.

Labor operation: 7248 19 99 60 T.U.

<u>Quantity</u>	<u>Part Number</u>	<u>Part Description</u>
1.00	8R0863385	Protective Film*
Up to 2.00	8E5886373	Grommet (if required)

-OR if cracks, leaks, and/or yellow discoloration ARE found-

Check fuel filter flange. Cracks, leaks, and/or yellow discoloration ARE found; replace fuel filter flange, install protective film, and reinstall seat frame.

Labor operation: 2066 19 99 150 T.U.

<u>Quantity</u>	<u>Part Number</u>	<u>Part Description</u>
1.00	8R0919679D	Fuel filter with flange (3.0L – PR # 1A2 only)
-OR-		
1.00	8R0919679E	Fuel filter with flange (2.0L – PR # 1A4 only)

-AND-

Up to 2.00	8E5886373	Grommet (if required)
1.00	8E0201263A	Quick coupling piece cap
1.00	1J0919133B	Seal Ring
1.00	8R0863385	Protective Film*

-Continue to next page-

-and ONLY if damage to wire harness seal is present-

Repair wire harness connector.

Labor operation: 2066 20 99 up to 100 T.U.

<u>Quantity</u>	<u>Part Number</u>	<u>Part Description</u>
As Required	Per ETKA	Connector
As Required	Per ETKA	Wires
As Required	Per ETKA	Connector Seal

Customer Letter Example (USA) Audi Q5

<MONTH YEAR>

<CUSTOMER NAME>

<CUSTOMER ADDRESS>

<CUSTOMER CITY STATE ZIPCODE>

This notice applies to your vehicle: <VIN>

NHTSA: 17V298

**Subject: Safety Recall 2028 – Fuel Pump Flange
Certain 2013-2017 Model Year Audi Q5**

Dear Audi Owner,

This notice is sent to you in accordance with the National Traffic and Motor Vehicle Safety Act. Audi has decided that a defect, which relates to motor vehicle safety, exists in certain 2013-2017 model year Audi Q5 vehicles. Our records show that you are the owner of a vehicle affected by this action.

What is the issue? On certain vehicles, the fuel pump flange may develop fine cracks or fissures, which could result in a fuel leak. Leaking fuel, in the presence of an ignition source, could lead to a fire causing injury and/or damage to property.

What will we do? To correct this defect, your authorized Audi dealer will inspect the fuel filter flange and if cracks, leaks, or yellow discoloration are present, the fuel pump flange will be replaced. This work will take about one hour to complete and will be performed for you free of charge.

What should you do? Please contact your authorized Audi dealer without delay to schedule this recall repair. For your convenience, you can also visit www.audiusa.com and click on the "Find a Dealer" link to locate a dealer near you and schedule this service.

Precautions you should take If you smell fuel in the vehicle, immediately contact the nearest authorized Audi dealer in order to have your vehicle inspected.

Lease vehicles and address changes If you are the lessor and registered owner of the vehicle identified in this action, the law requires you to forward this letter immediately via first-class mail to the lessee within ten (10) days of receipt. If you have changed your address or sold the vehicle, please fill out the enclosed prepaid Owner Reply card and mail it to us so we can update our records.

Reimbursement of Expenses If you have previously paid for repairs relating to the condition described in this letter, the enclosed form explains how to request reimbursement. We would be pleased to review your reimbursement request.

Can we assist you further? If your authorized Audi dealer fails or is unable to complete this work free of charge within a reasonable time, please contact Audi Customer Experience at 1-800-253-2834 or via our "Contact Us" page at www.audiusa.com.

Checking your vehicle for open Recalls and Service Campaigns To check your vehicle's eligibility for repair under this or any other recall/service campaign, please visit the **Recall/Service Campaign Lookup** tool at www.audiusa.com and enter your Vehicle Identification Number (VIN).

If you still cannot obtain satisfaction, you may file a complaint with: The Administrator, National Highway Traffic Safety Administration, 1200 New Jersey Avenue, SE., Washington, DC 20590; or call the toll-free Vehicle Safety Hotline at 1-888-327-4236 (TTY: 1-800-424-9153); or go to <http://www.safercar.gov>.

We apologize for any inconvenience this matter may cause; however we are taking this action to help ensure your safety and continued satisfaction with your vehicle.

Sincerely,

Audi Customer Protection

Customer Letter Example (USA) Audi Q7

<MONTH YEAR>

<CUSTOMER NAME>

<CUSTOMER ADDRESS>

<CUSTOMER CITY STATE ZIPCODE>

This notice applies to your vehicle: <VIN>

NHTSA: 17V298

**Subject: Safety Recall 20Z8 – Fuel Pump Flange
Certain 2013-2015 Model Year Audi Q7**

Dear Audi Owner,

This notice is sent to you in accordance with the National Traffic and Motor Vehicle Safety Act. Audi has decided that a defect, which relates to motor vehicle safety, exists in certain 2013-2015 model year Audi Q7 vehicles. Our records show that you are the owner of a vehicle affected by this action.

- What is the issue?** On certain vehicles, the fuel pump flange may develop fine cracks or fissures, which could result in a fuel leak. Leaking fuel, in the presence of an ignition source, could lead to a fire causing injury and/or damage to property.
- What will we do?** To correct this defect, your authorized Audi dealer will inspect the fuel filter flange and if cracks, leaks, or yellow discoloration are present, the fuel pump flange will be replaced. This work will take about one hour to complete and will be performed for you free of charge.
- What should you do?** Please contact your authorized Audi dealer without delay to schedule this recall repair. For your convenience, you can also visit www.audiusa.com and click on the "Find a Dealer" link to locate a dealer near you and schedule this service.
- Precautions you should take** If you smell fuel in the vehicle, immediately contact the nearest authorized Audi dealer in order to have your vehicle inspected.
- Lease vehicles and address changes** If you are the lessor and registered owner of the vehicle identified in this action, the law requires you to forward this letter immediately via first-class mail to the lessee within ten (10) days of receipt. If you have changed your address or sold the vehicle, please fill out the enclosed prepaid Owner Reply card and mail it to us so we can update our records.
- Reimbursement of Expenses** If you have previously paid for repairs relating to the condition described in this letter, the enclosed form explains how to request reimbursement. We would be pleased to review your reimbursement request.
- Can we assist you further?** If your authorized Audi dealer fails or is unable to complete this work free of charge within a reasonable time, please contact Audi Customer Experience at 1-800-253-2834 or via our "Contact Us" page at www.audiusa.com.
- Checking your vehicle for open Recalls and Service Campaigns** To check your vehicle's eligibility for repair under this or any other recall/service campaign, please visit the **Recall/Service Campaign Lookup** tool at www.audiusa.com and enter your Vehicle Identification Number (VIN).

If you still cannot obtain satisfaction, you may file a complaint with: The Administrator, National Highway Traffic Safety Administration, 1200 New Jersey Avenue, SE., Washington, DC 20590; or call the toll-free Vehicle Safety Hotline at 1-888-327-4236 (TTY: 1-800-424-9153); or go to <http://www.safercar.gov>.

We apologize for any inconvenience this matter may cause; however we are taking this action to help ensure your safety and continued satisfaction with your vehicle.

Sincerely,

Audi Customer Protection

Customer Letter Example (CANADA) Audi Q5

<MONTH YEAR>

<CUSTOMER NAME>

<CUSTOMER ADDRESS>

<CUSTOMER CITY STATE ZIPCODE>

This notice applies to your vehicle: <VIN>

**Subject: Safety Recall 20Z8 – Fuel Pump Flange
Certain 2013-2017 Model Year Audi Q5**

Dear Audi Owner,

This notice is sent to you in accordance with the requirements of the Motor Vehicle Safety Act. Audi has decided that a defect, which relates to motor vehicle safety, exists in certain 2013-2017 model year Audi Q5 vehicles. Our records show that you are the owner of a vehicle affected by this action.

- What is the issue?** On certain vehicles, the fuel pump flange may develop fine cracks or fissures, which could result in a fuel leak. Leaking fuel, in the presence of an ignition source, could lead to a fire causing injury and/or damage to property.
- What will we do?** To correct this defect, your authorized Audi dealer will inspect the fuel filter flange and if cracks, leaks, or yellow discoloration are present, the fuel pump flange will be replaced. This work will take about one hour to complete and will be performed for you free of charge.
- What should you do?** Please contact your authorized Audi dealer without delay to schedule this recall repair.
- Precautions you should take** If you smell fuel in the vehicle, immediately contact the nearest authorized Audi dealer in order to have your vehicle inspected.
- Lease vehicles and address changes** If you are the lessor and registered owner of the vehicle identified in this action, the law requires you to forward this letter immediately via first-class mail to the lessee within ten (10) days of receipt. If you have changed your address or sold the vehicle, please fill out the enclosed prepaid Owner Reply card and mail it to us so we can update our records.
- Reimbursement of Expenses** If you have previously paid for repairs relating to the condition described in this letter, the enclosed form explains how to request reimbursement. We would be pleased to review your reimbursement request.
- Can we assist you further?** If your authorized Audi dealer fails or is unable to complete this work free of charge within a reasonable time, please contact Audi Customer Relations Monday through Friday from 8AM to 8PM EST at 1-800-822-2834 or via our “Contact Audi Canada” page at www.audi.ca.

We apologize for any inconvenience this matter may cause; however we are taking this action to help ensure your safety and continued satisfaction with your vehicle.

Sincerely,

Audi Customer Protection

Customer Letter Example (CANADA) Audi Q7

<MONTH YEAR>

<CUSTOMER NAME>

<CUSTOMER ADDRESS>

<CUSTOMER CITY STATE ZIPCODE>

This notice applies to your vehicle: <VIN>

**Subject: Safety Recall 20Z8 – Fuel Pump Flange
Certain 2013-2015 Model Year Audi Q7**

Dear Audi Owner,

This notice is sent to you in accordance with the requirements of the Motor Vehicle Safety Act. Audi has decided that a defect, which relates to motor vehicle safety, exists in certain 2013-2015 model year Audi Q7 vehicles. Our records show that you are the owner of a vehicle affected by this action.

What is the issue? On certain vehicles, the fuel pump flange may develop fine cracks or fissures, which could result in a fuel leak. Leaking fuel, in the presence of an ignition source, could lead to a fire causing injury and/or damage to property.

What will we do? To correct this defect, your authorized Audi dealer will inspect the fuel filter flange and if cracks, leaks, or yellow discoloration are present, the fuel pump flange will be replaced. This work will take about one hour to complete and will be performed for you free of charge.

What should you do? Please contact your authorized Audi dealer to schedule this recall repair without delay.

Precautions you should take If you smell fuel in the vehicle, immediately contact the nearest authorized Audi dealer in order to have your vehicle inspected.

Lease vehicles and address changes If you are the lessor and registered owner of the vehicle identified in this action, the law requires you to forward this letter immediately via first-class mail to the lessee within ten (10) days of receipt. If you have changed your address or sold the vehicle, please fill out the enclosed prepaid Owner Reply card and mail it to us so we can update our records.

Reimbursement of Expenses If you have previously paid for repairs relating to the condition described in this letter, the enclosed form explains how to request reimbursement. We would be pleased to review your reimbursement request.

Can we assist you further? If your authorized Audi dealer fails or is unable to complete this work free of charge within a reasonable time, please contact Audi Customer Relations Monday through Friday from 8AM to 8PM EST at 1-800-822-2834 or via our "Contact Audi Canada" page at www.audi.ca.

We apologize for any inconvenience this matter may cause; however we are taking this action to help ensure your safety and continued satisfaction with your vehicle.

Sincerely,

Audi Customer Protection

NOTE

Damages resulting from improper repair or failure to follow these work instructions are the dealer's responsibility and are not eligible for reimbursement under this action.

Required Parts

Criteria 4L (Q7 Models)

<u>Quantity</u>	<u>Part Number</u>	<u>Part Description</u>
1	8R0863385	Protective Film
4	N 90965001	Socket head bolt
1	N 91040702	Socket head bolt
-OR-		
1	7L8919679	Fuel filter with flange
1	1J0919133B	Seal Ring
4	N 90965001	Socket head bolt
1	N 91040702	Socket head bolt
1	8R0863385	Protective Film

Criteria 8R (Q5 Models)

<u>Quantity</u>	<u>Part Number</u>	<u>Part Description</u>
1	8R0863385	Protective Film
Up to 2	8E5886373	Grommet (if required)
-OR-		
1	8R0919679D	Fuel filter with flange (3.0L – PR # 1A2 only)
	-OR-	
	8R0919679E	Fuel filter with flange (2.0L – PR # 1A4 only)
-AND-		
1	8E0201263A	Quick coupling piece cap
1	1J0919133B	Seal Ring
Up to 2	8E5 886 373	Grommet (if required)
1	8R0863385	Protective Film

Required Tools

 <p>Fuel Extracting Device -VAS5190A- (or equivalent)</p>	 <p>Fuel Extraction - Adapter Set VAS5190/10 (or equivalent)</p>
 <p>Wrench - Fuel Sending Unit -T10202-</p>	 <p>Pry lever -80-200- (or equivalent)</p>
 <p>Trim Removal Wedge -3409- (or equivalent)</p>	 <p>Airbag Lockout Adapter -VAS6235-</p>
 <p>Airbag Lockout Adapter -VAS6280-</p>	 <p>Torque Wrench (4 - 20 Nm) -1410- (or equivalent)</p>
 <p>Torque Wrench (40 – 200 Nm) -1332- (or equivalent)</p>	 <p>Safety Gloves and Safety Goggles</p>

Repair Instruction

Section A - Check for Previous Repair

Applicable criteria ID(s)	Campaign/Action Status
01 ← 2	Open ← 1

EXAMPLE

- Enter the VIN in Elsa and proceed to the “Campaign/Action” screen.

TIP

On the date of repair, print this screen and keep a copy with the repair order.

- Confirm the Campaign/Action is open <arrow 1>. If the status is closed, no further work is required.
- Note the Applicable Criteria ID <arrow 2> for use in determining the correct work to be done and corresponding parts associated.

Proceed to Section B for Audi Q7 (criteria 4L).

Proceed to Section E for Audi Q5 (criteria 8R).

Section B – Repair Procedure, Performing work on Audi Q7 (criteria 4L)

WARNING

Risk of injury. Refer to “Warning and Safety Precautions”, found in **Appendix A** at the end of this document.

NOTE

- Damages resulting from improper repair or failure to follow these work instructions are the dealer's responsibility and are not eligible for reimbursement under this action.
- This procedure must be read in its entirety prior to performing the repair.
- Due to variations in vehicle equipment and options, the steps/illustrations in this work procedure may not identically match all affected vehicles.
- Diagnosis and repair of pre-existing conditions in the vehicle are not covered under this action.



- Check the vehicle fuel level displayed on the instrument cluster <1>.
- Record the vehicle fuel level on the repair order.

NOTE

If the fuel level in the vehicle is at or below ½ tank, then it is possible to perform all operations in this bulletin without extracting any fuel using the Fuel Extracting Device -VAS5190A-. Record the fuel level before continuing on to battery disconnection.

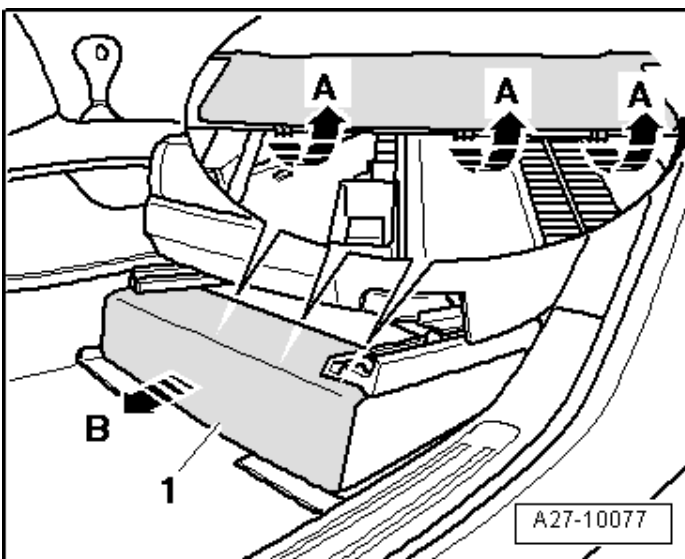

Perform battery disconnect:

- Position driver's seat as far back as possible. Use the entire seat adjustment range to do this.
- Switch off the ignition.
- Reach under seat and release retaining clips on back side of cover <1> in direction of <arrows A>.
- Then remove cover in direction of arrow from driver's seat console.

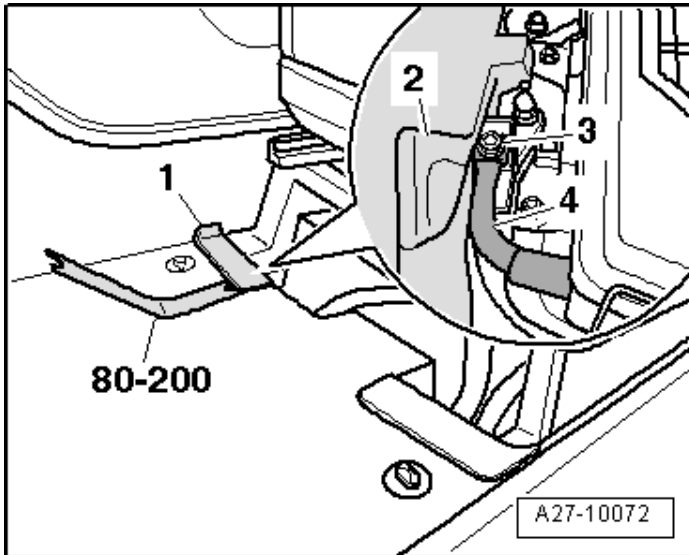

- Pry cover <1> with Pry Lever -80-200- (or equivalent) from floor covering.
- Raise floor covering <2> slightly in ground wire area.
- Remove nut <3> and remove ground wire <4> from ground point.

NOTE

- The battery must be disconnected before removing fuel from the vehicle. If fuel removal is required and the battery is not disconnected, it is possible to experience fuel level sender faults upon completion of this campaign.
- Consequential diagnosis or damage resulting from failure to disconnect the battery is not covered under this campaign.

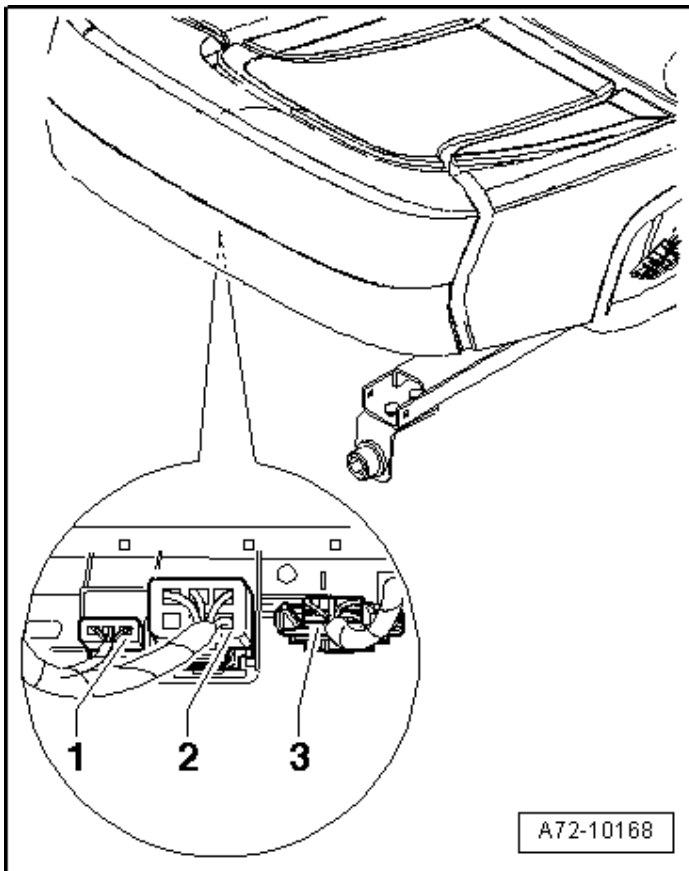

- Create photos or sketches of under seat wiring location securing and routing.
- Remove seat heating connectors <2> and <3>.

WARNING

Before handling airbag units (for example, disconnecting electrical connector), the person handling it must “discharge static electricity”. This can be done by touching the door striker, for example.

- Remove yellow airbag connector <1>.

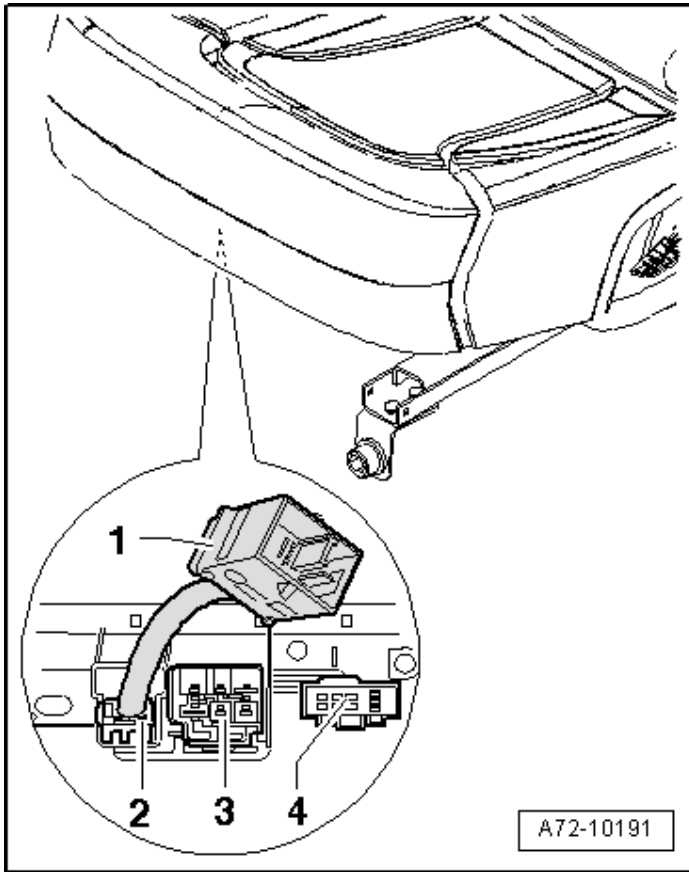

- Connect Airbag Lockout Adapter -VAS6235- or Airbag Lockout Adapter -VAS6280- to airbag connector.
- Ensure airbag adapter engages correctly.
- Unclip wiring cable guide at connector station on seat.

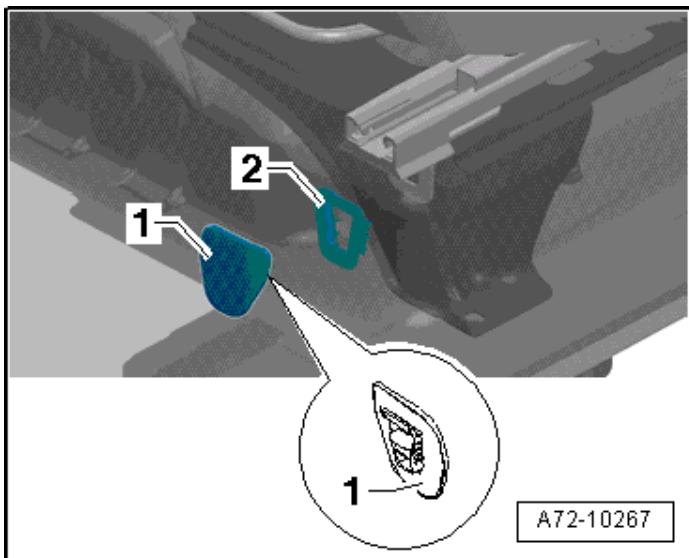

- Remove seat rail cover trim <1> using Trim Removal Wedge -3409-.
- Pry seat rail cover <1> at sides out of frame <2>.

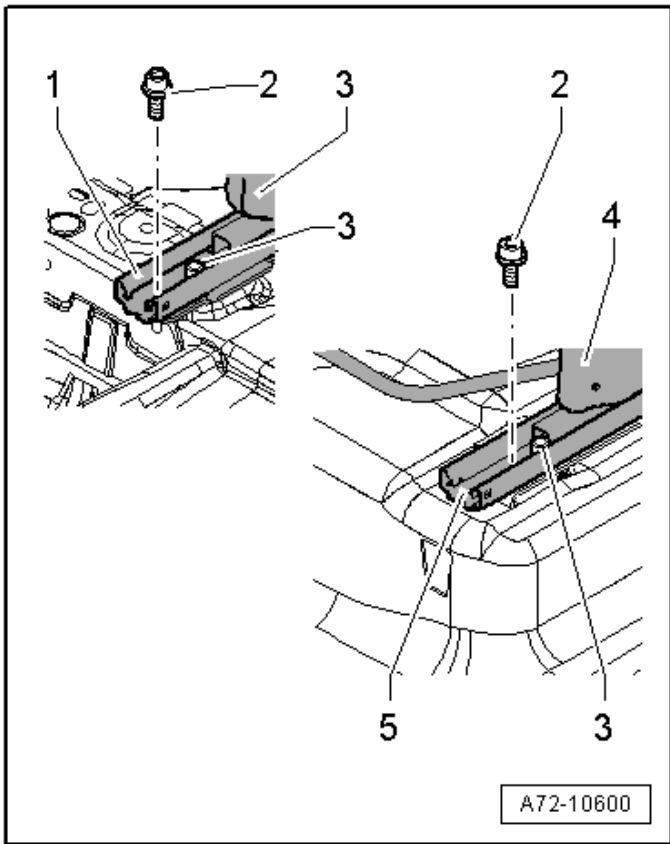

- Remove the seat rail stop bolts <2> (if required).

TIP

- The removal of the seat rail stop bolts will allow the seat frame to slide forward enough to gain access to the rear seat frame mounting bolts if the vehicle is not equipped with a third row entry assist handle.
- If the vehicle is equipped with a third row entry assist access handle on the rear of the second row backrest, lift the third row entry assist handle and fold the seat to the full forward position to gain access to the rear seat bolts.

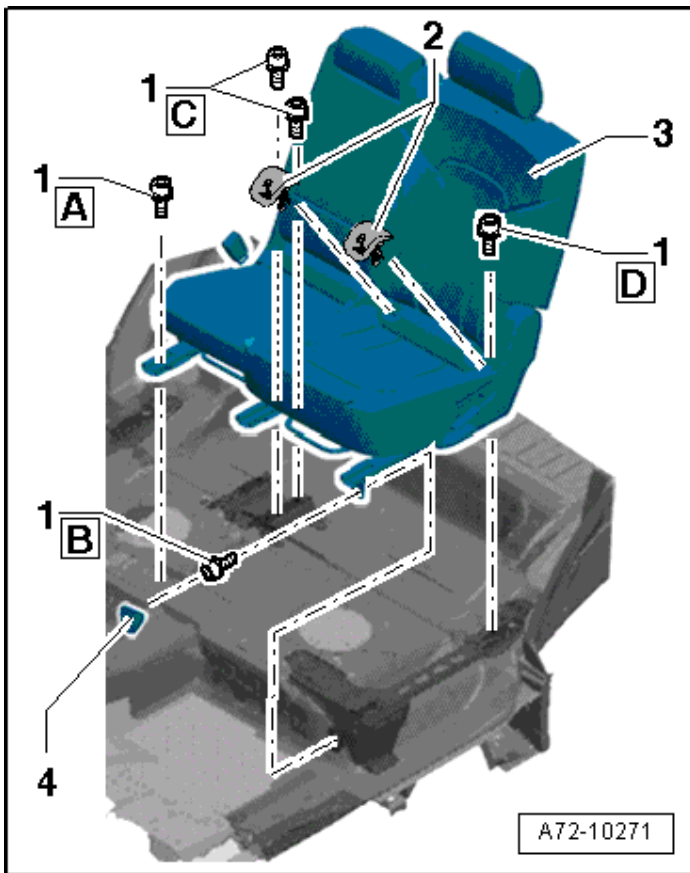

- Remove the second row front seat frame bolts <1A, 1B>.
- Slide the seat frame forward using the third row entry assist handle (if equipped), or slide the seat forward beyond the seat rail stop bolts to gain clear access to and remove the rear seat frame bolts <1C (x2) and 1D>.
- Lift seat frame assembly <3> out of the vehicle.

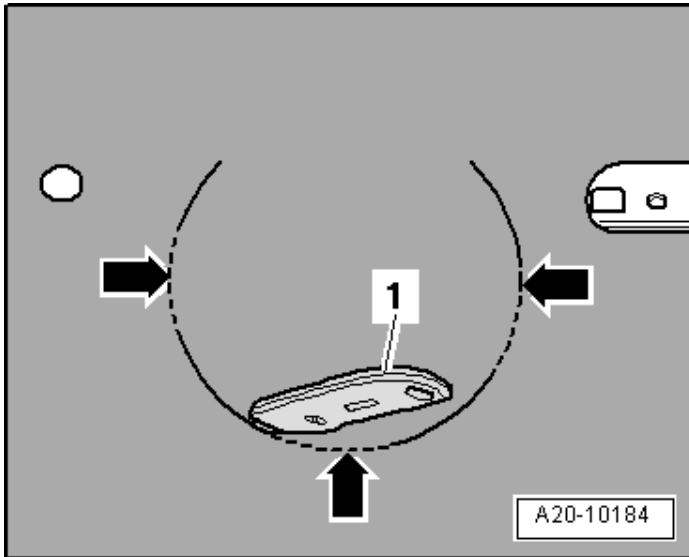

- If necessary, cut the floor covering along the perforation <arrows> on the left side with a carpet knife <1>.

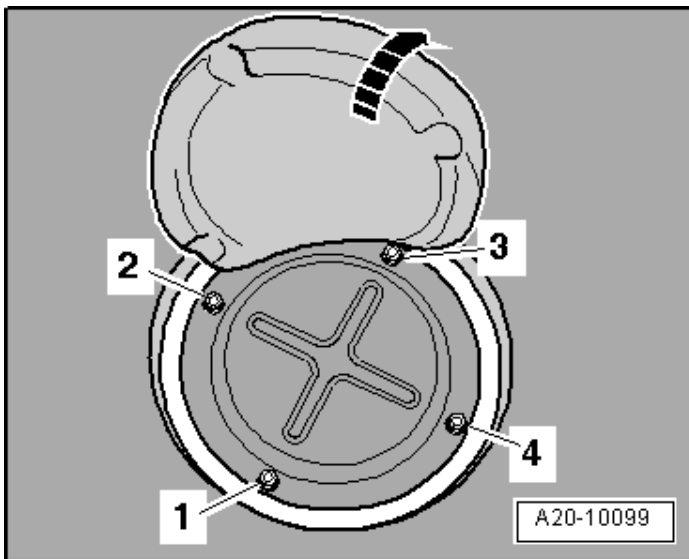

- If necessary, fold the floor covering to the side in direction of <arrow>.
- Remove screws <1> through <4> and remove left locking flange cover.



- Clean top of fuel filter with suitable plastic cleaner.

! NOTE
 Use a suitable cloth to apply the plastic cleaner; do not spray the plastic cleaner directly onto the flange.

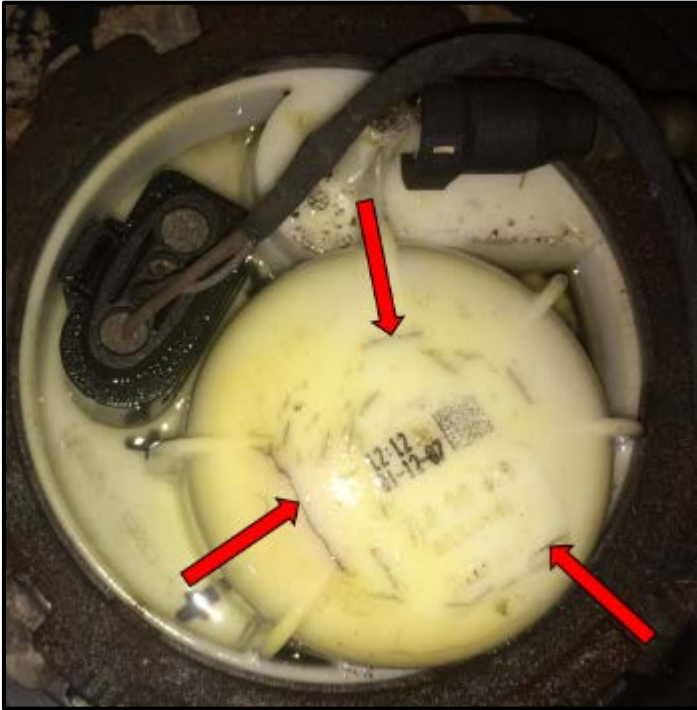

- If there is a visible presence of leaking fuel;
 - **Continue to Section D and Replace the Fuel Filter Flange and install the protective film.**
 - **All others continue to the next step.**



- If there are no signs of leaking present, but there **ARE** cracks <circle> and/or yellow discoloration present;
 - **Continue to Section D and Replace the Fuel Filter Flange and install the protective film.**
 - **All others continue to the next step.**



- If there are **NO** cracks, leaks, and/or yellow discoloration present;
 - **Continue to Section C and install the protective film and reinstall the seat frame.**

Section C – Repair Procedure, Installing protective film on Audi Q7 (criteria 4L)



- Apply protective film as shown. Start application from the center and work the protective film towards the outside edges of the fuel pump flange taking care to eliminate air gaps or bubbles under the film.
- Use care when applying protective film so that no dust or dirt comes in contact with the adhesion side of the film.

NOTE

The fuel pump flange must be fully installed (with the locking ring in place) when the protective film is applied to ensure that part of the protective film does not get trapped between the top section of the fuel pump flange and the locking ring.

Part Number	Part Description
8R0863385	Protective Film

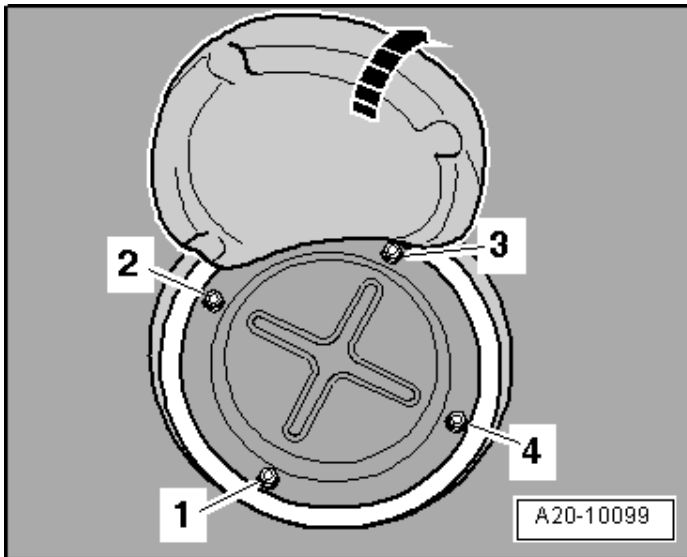

- Reinstall left locking flange cover and reinstall screws <1> through <4>.
- If necessary, fold the floor covering carpet closed to conceal the locking flange cover.

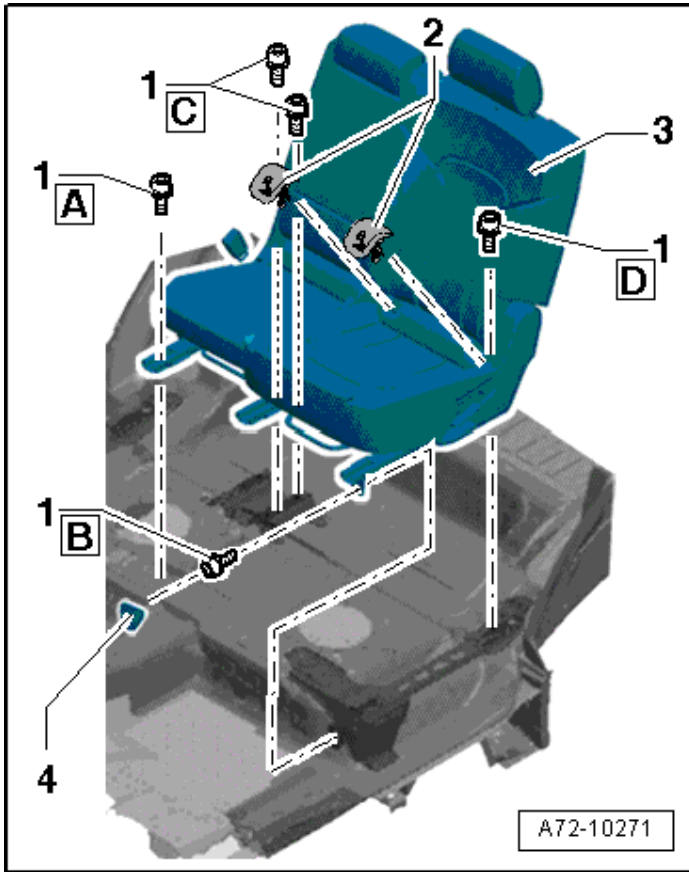

- Reinstall seat frame assembly <3> into the vehicle.
- Reinstall new seat frame bolts <1A, 1B, 1C (x2), and 1D>. Tighten bolts to 50 Nm.

Part Number	Part Description
N 90965001	Socket head bolt (x4)
N 91040702	Socket head bolt (x1)

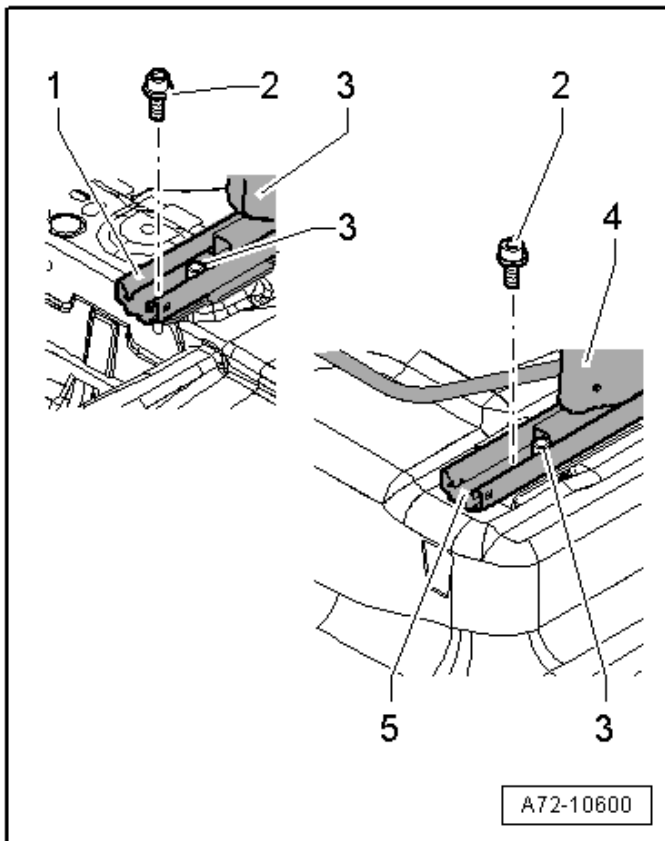

- Reinstall the seat rail stop bolts <2>. Tighten the bolts to 20 Nm.

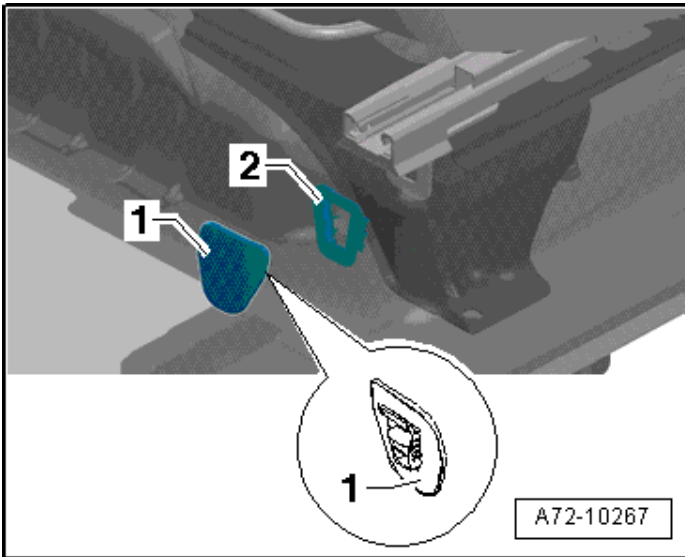

- Reinstall seat rail cover trim <1> onto seat frame <2>.

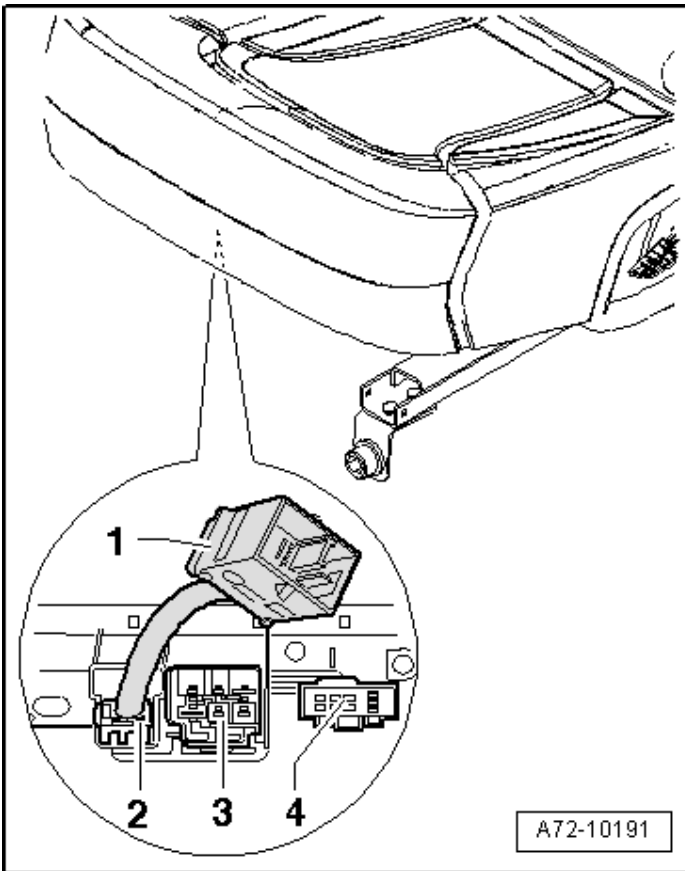

- Using the previously taken photos or sketches of under seat wiring location securing and routing, reinstall the wiring and route accordingly.
- Reinstall seat heating connectors <3> and <4>.

WARNING

Before handling airbag units (for example, reconnecting electrical connector), the person handling it must "discharge static electricity". This can be done by touching the door striker, for example.

- Remove Airbag Lockout Adapter -VAS6235- or Airbag Lockout Adapter -VAS6280- <1> from airbag connector.
- Reinstall yellow airbag connector <2>.

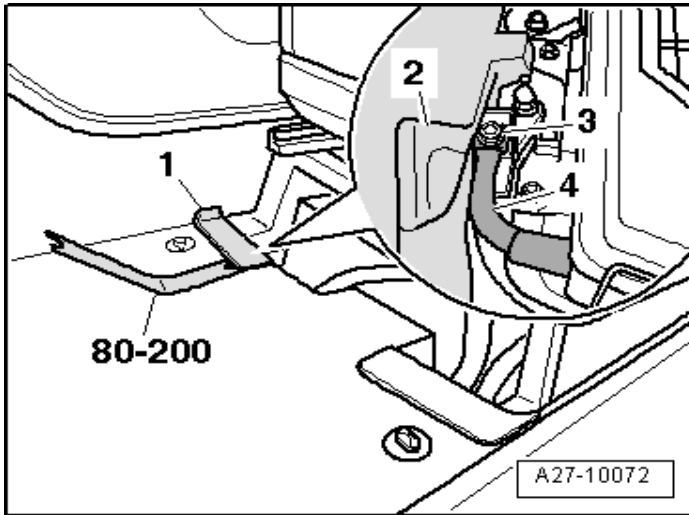

NOTE

- The connector for the Battery Monitoring Control Module must be connected when connecting the ground wire to the ground point on vehicles with Battery Monitoring Control Module -J367-.
- If the connector on the Battery Monitoring Control Module -J367- comes loose when connecting the battery, wait 30 seconds before connecting it again.

- Reconnect battery ground.
- To connect, position ground wire terminal clamp on ground point and tighten nut to 20 Nm.
- Reinstall battery cover assembly.
- Check DTC memories of all control modules and erase any under voltage DTCs using the Vehicle Diagnostic Tester.

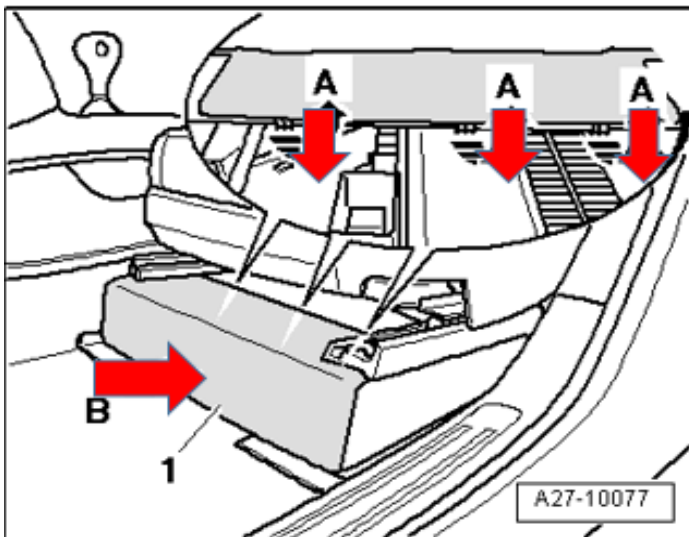

NOTE

After connecting the power supply, the ABS warning lamp may only go out after the vehicle has been driven a few yards.



- Turn on the ignition.
- Cycle the ignition four to five times to prime the fuel system and verify there are no DTC's present and no warning lamps illuminated.
- Start the vehicle to verify fuel system functionality. Make sure to check for any fuel leaks before delivering the vehicle to the customer.
- Check the vehicle fuel level displayed on the instrument cluster <1>.
- Refer to the vehicle fuel level on the repair order and verify the proper operation of the fuel level sensor.
- Reset customer convenience basic settings (i.e. one touch windows, instrument cluster clock, etc.).
- Repair Complete - **Proceed to section H.**

Section D – Repair Procedure, Replacing Fuel Filter Flange on Q7 (criteria 4L)

NOTE

- After replacement of the fuel filter flange, application of the Protective Film is required. Follow the work instructions for additional details.
- If the electrical harness requires repair, refer to ETKA and ELSA for additional required parts and repair information.



- If the fuel filter flange was leaking fuel, inspect the wiring harness connector carefully for damage due to fuel wicking into the weather pack seals.
- If damage to the weather pack seal and/or wiring harness is discovered, be sure to order the appropriate wiring and connector to correctly repair the damaged harness.

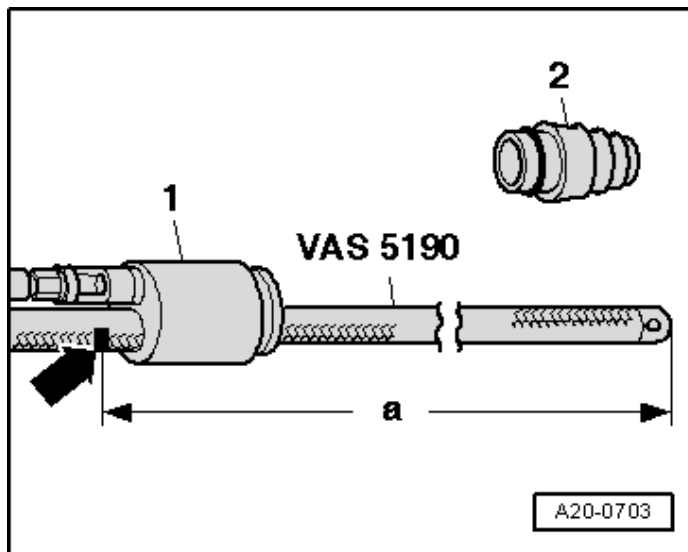

- Drain fuel down to approximately $\frac{1}{2}$ of a tank using Fuel Extraction Unit -VAS5190-, if necessary.
- Remove the cone piece <2> from the shaft piece <1> on the Fuel Extraction Unit -VAS5190-.
- Using insulating tape, apply a mark <arrow> on hose at length <a> = 177.5 cm from end of suction hose.

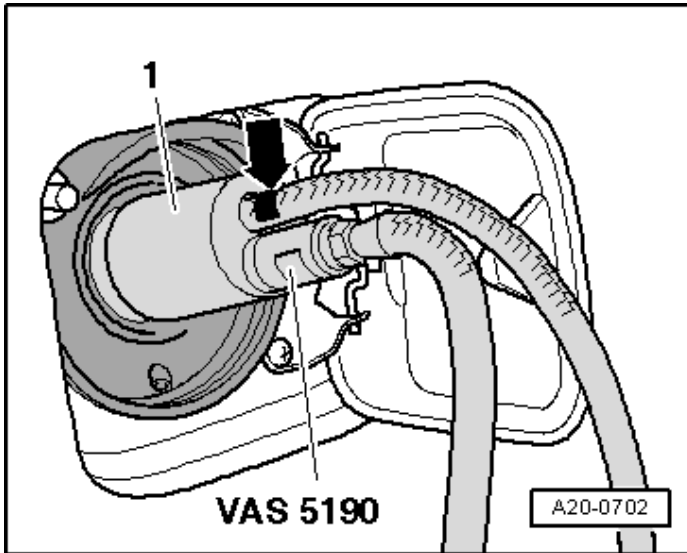

- Remove the fuel cap from the fuel filler tube.
- Install the adapter <1> for the Fuel Extraction Unit -VAS5190- on the fuel tank filler tube.
- Push the suction hose into fuel tank until the mark applied earlier <arrow> is positioned on shaft piece.

⚠ CAUTION

Proper safety equipment is required. Wear safety goggles and protective gloves when working with gasoline, or any other fuel.

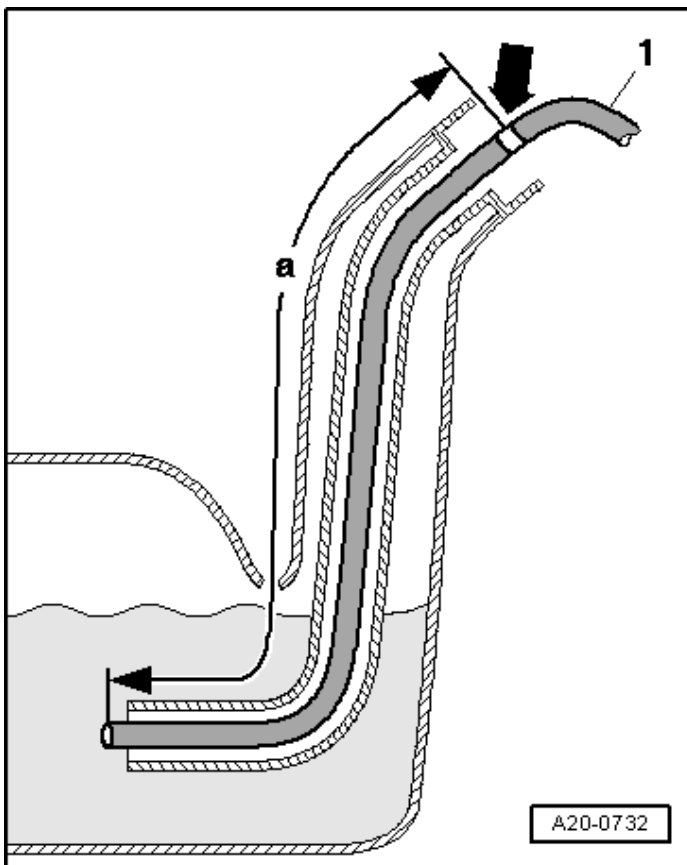

ⓘ NOTE

- If using a siphoning device without shaft piece, proceed principally in the same manner.
- In this case, make a mark <arrow> on the hose <a> = 140 cm from end of suction hose using insulating tape. The suction hose is inserted correctly when the marking applied earlier aligns with the lip of the fuel filler neck.
- If the hose can only be inserted with difficulty, coat it thinly with engine oil. Never use lubricants containing silicon.

- Empty fuel tank to approximately ½ full via fuel filler tube.
- Carefully pull out the suction hose.

ⓘ NOTE

Accurately record the amount of fuel in liters removed from the vehicle using the sightglass measurement viewport on the side of the -VAS 5190- Fuel Extraction Unit. It is required to return to the fuel tank precisely the amount of fuel removed from the fuel tank. Failure to do so may result in fuel sending unit faults.

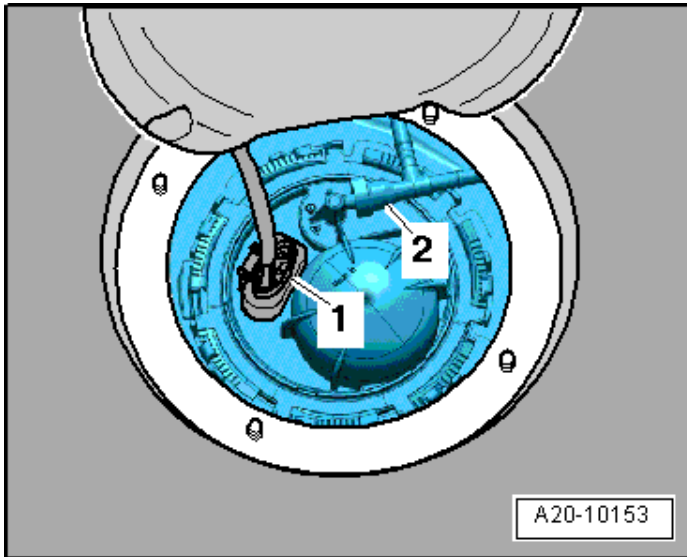

- Clean and/or vacuum the area around the fuel pump opening to ensure no debris falls into the fuel tank during the repair.
- Disconnect filter flange electrical connector <1>.
- Remove the fuel tank vent line connector <2> from the filter flange by squeezing the release tab between the finger and thumb, pushing in on the connector, and then pulling off.

NOTE

- Do not use pliers or other tools on the fuel line connector or damage to the connector may occur.
- Damage to the fuel line connector due to improper removal/installation may cause the connector to not fasten securely upon reinstallation, causing a leak.
- A damaged fuel line connector requires replacement of the fuel line.
- Consequential damage to the fuel line connector due to improper removal/installation is not covered under this campaign.



WARNING

There is a risk of fuel leaking out from the filled fuel filter flange. Lay cloths, rags, or other absorbent material below to catch the leaking fuel.

CAUTION

Dispose of all absorbent material contaminated with gasoline or any other fuel in accordance with Local and Federal guidelines.

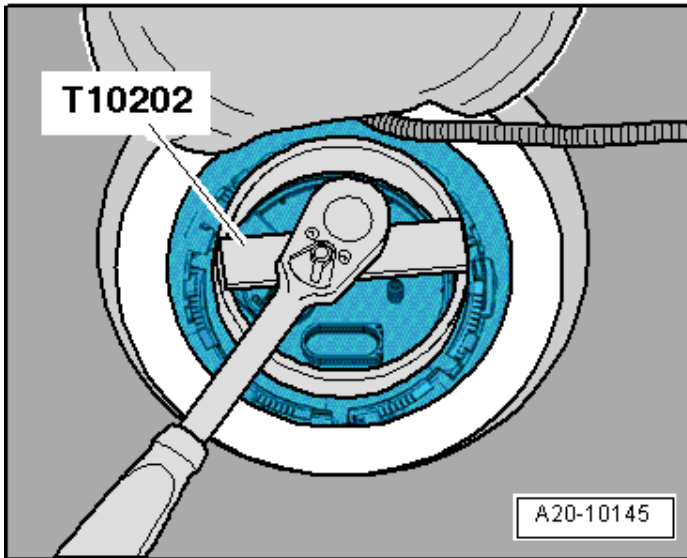

- Using Fuel Sending Unit wrench -T10202-, remove the locking ring from the fuel pump flange by turning counterclockwise.

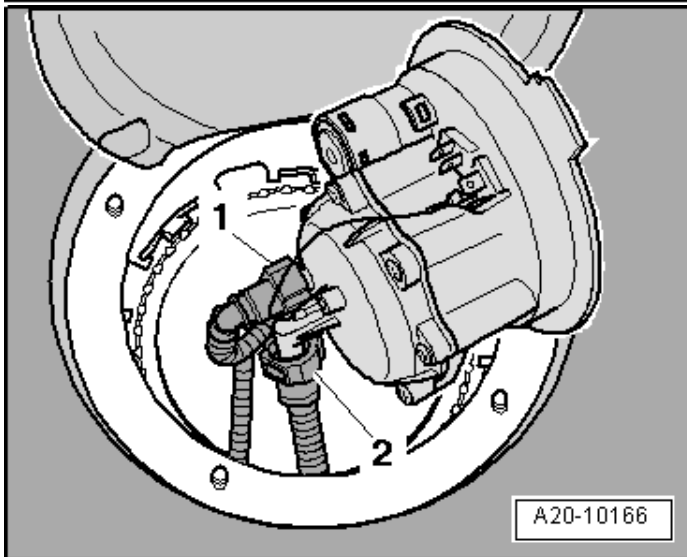

- Disconnect fuel lines <1> and <2> from left locking flange by squeezing the release tab between the finger and thumb, pushing IN on the connector, then pulling OFF.
- Remove left locking flange with fuel filter housing and seal.

NOTE

- Do not use pliers or other tools on the fuel line connector or damage to the connector may occur.
- Damage to the fuel line connector due to improper removal/installation may cause the connector to not fasten securely upon reinstallation, causing a leak.
- A damaged fuel line connector requires replacement of the fuel line.
- Consequential damage to the fuel line connector due to improper removal/installation is not covered under this campaign.



- Install new fuel filter flange assembly into fuel tank.
- Discard the old fuel filter flange seal ring, and use new fuel filter flange ring seal. Install the seal dry. Do not lubricate the seal.

Part Number	Part Description
7L8919679	Fuel Filter Flange
1J0919133B	Seal Ring

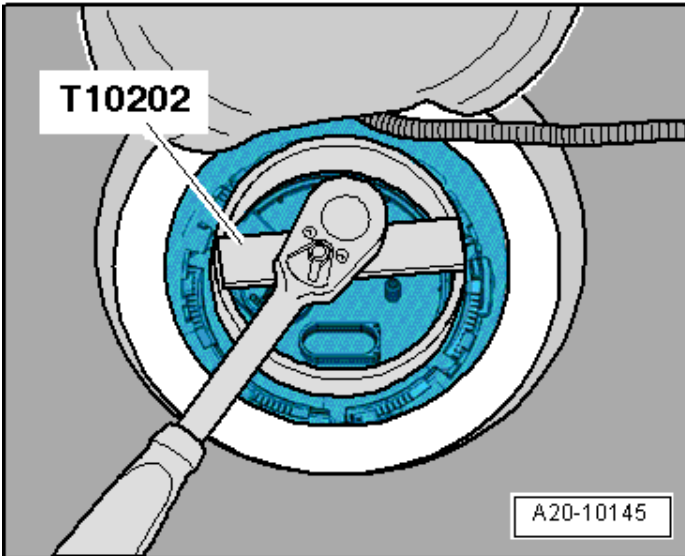

- Reinstall the fuel filter flange locking ring by turning clockwise. Torque the locking flange to 110 Nm.



- If required, repair the wiring harness connector, wiring, and weather pack seals before reconnecting the connector to the fuel filter flange.

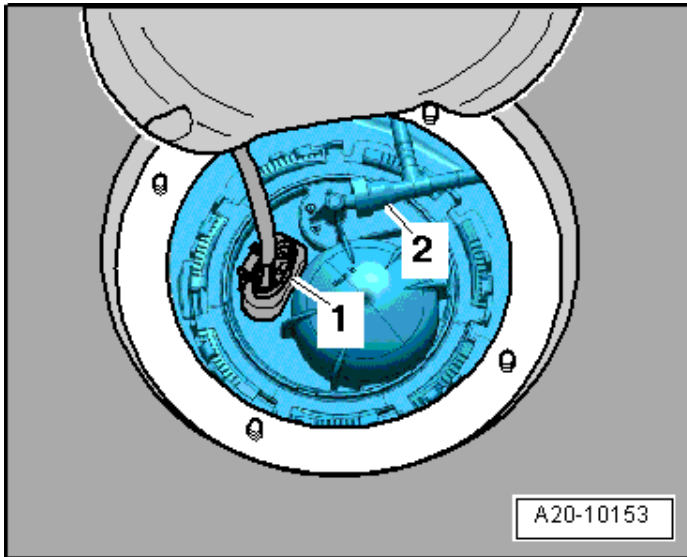

- Reconnect the filter flange electrical connector <1> and push into place until you feel and hear the audible click.
- Reconnect the fuel tank vent line connector <2> and push into place until you feel and hear the audible click.

NOTE

After installation gently push, then pull, on both the electrical connector and fuel vent line connector to verify they are securely attached.

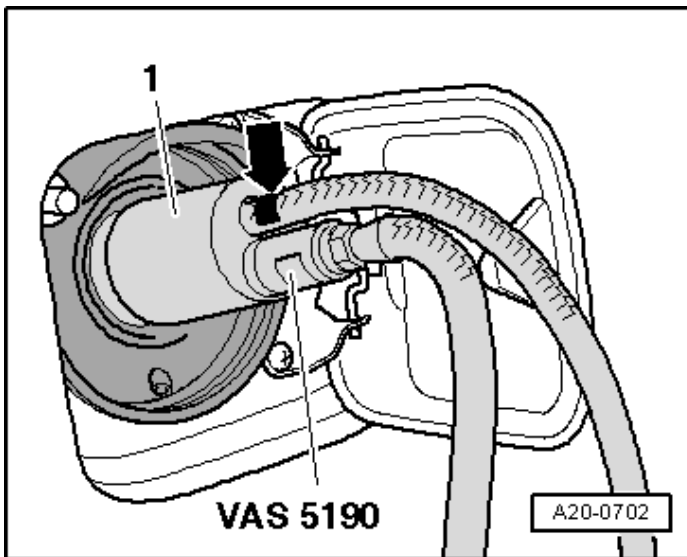

- If fuel was removed due to replacement of the fuel filter flange, dispense recovered fuel contained in the -VAS 5190- Fuel Extracting Device back into the vehicle fuel tank at this time.

CAUTION

Refer to the previously recorded fuel measurement obtained from the -VAS 5190- Fuel Extraction Unit sightglass. Be certain to refill the vehicle fuel tank with the same amount of fuel that was originally extracted from the vehicle or fuel sending unit faults may occur.

- **Proceed to Section C to install the protective film and reinstall the seat frame.**

Section E – Repair Procedure, Performing work on Audi Q5 (criteria 8R)



- Check the vehicle fuel level displayed on the instrument cluster <A>.
- Record the vehicle fuel level on the repair order.

NOTE

If the fuel level in the vehicle is at or below $\frac{1}{4}$ tank, then it is possible to perform all operations in this bulletin without extracting any fuel using the Fuel Extracting Device -VAS5190A-. Record the fuel level before continuing on to battery disconnection.

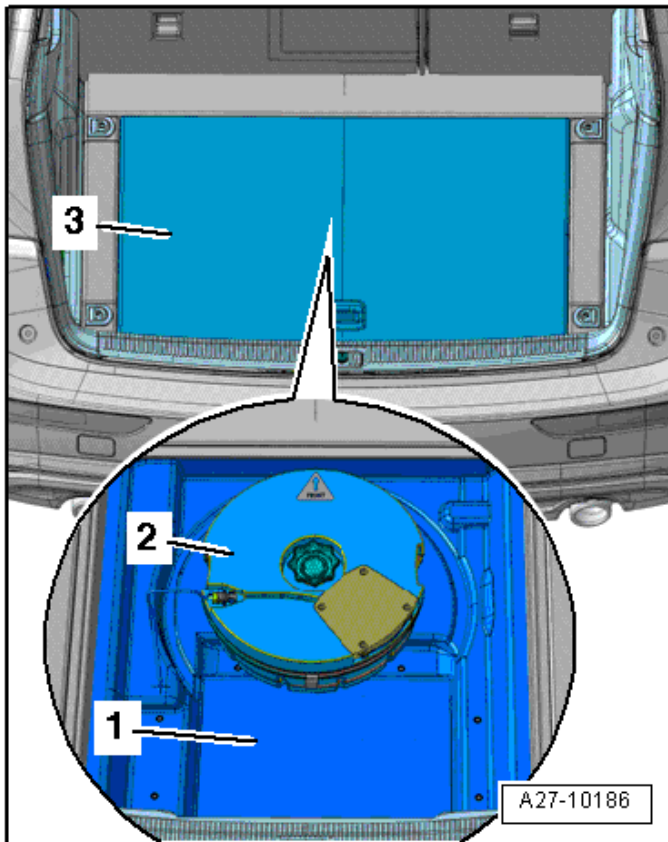

Disconnect the Battery:

- Turn off the ignition and remove the key.
- Remove the luggage compartment floor covering <3>.
- Remove the dirt tray, if applicable.
- If equipped, remove the subwoofer <2>.
- Fold back the carpet <1> over the cover.

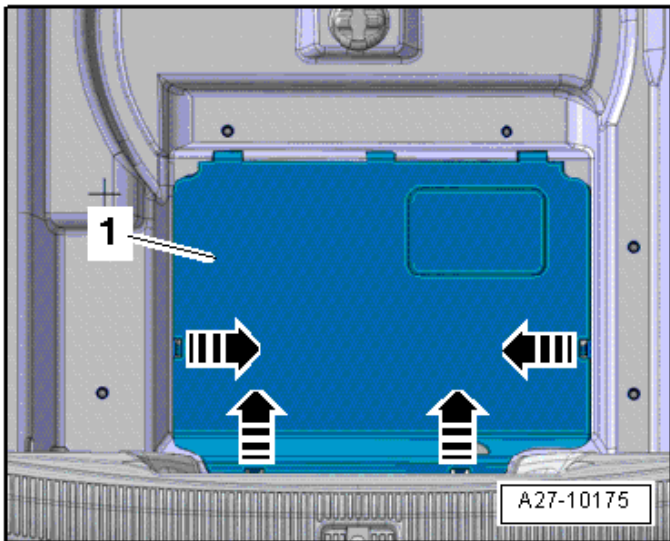

- Unlock the retaining tabs <arrows> and open the cover <1>.

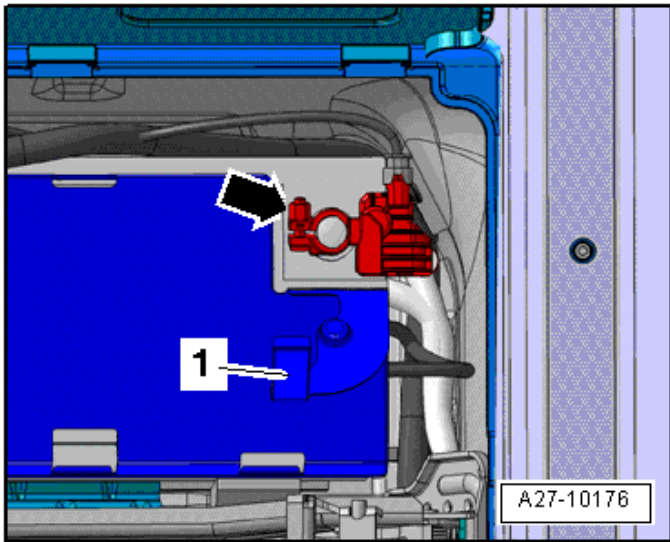

- Open the cover <1> over the battery negative terminal.
- Loosen the nut several turns and remove the battery ground cable terminal <arrow> from the battery pole.

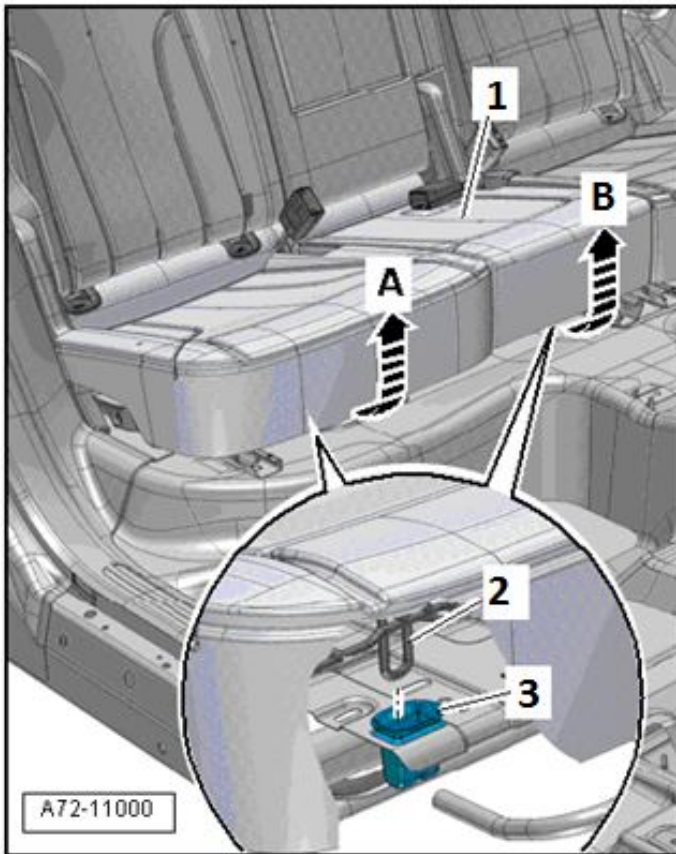

- Remove LATCH covers.
- Remove right (passenger side) rear seat cushion <A>.
- Lift up on the seat cushion <A> until the cushion frame <2> releases from the grommets <3>.
- Disconnect the seat heating electrical connector (if equipped).

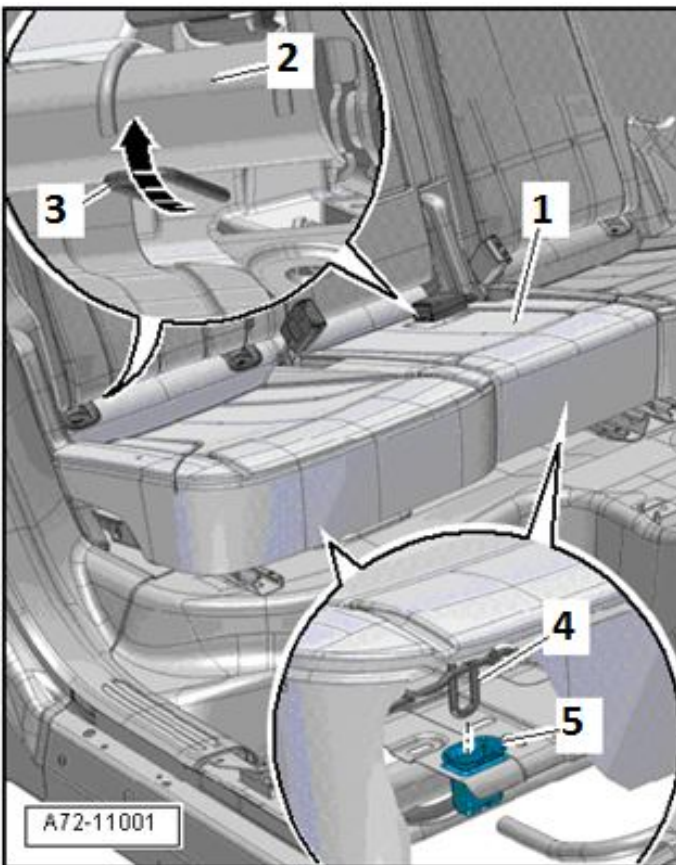

- Remove right rear cushion <2> by lifting upwards and pulling outward to remove the seat cushion.

CAUTION

- DO NOT remove the left side rear (drivers' side) seat cushion or frame assembly. It is only necessary to remove the right side (passenger side) cushion and frame to complete this operation.
- Removal of the incorrect seat could require replacement of the seat grommets for proper reinstallation. This recall covers up to two grommets <5> (if required).

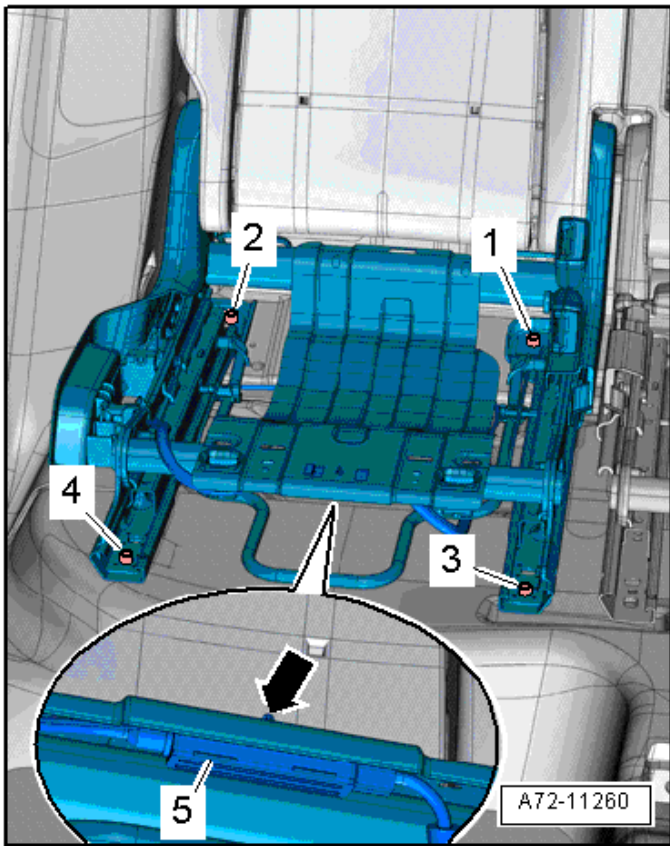

- Remove the four right rear seat frame bolts <1, 2, 3, and 4> using hand tools.

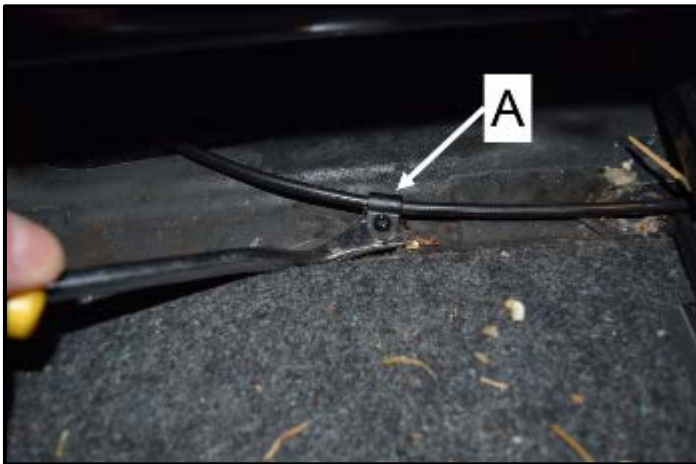

- For vehicles equipped with adjustable seat frames, slide the seat frame forward and unclip the seat frame adjustment cable from the threaded tab <A>.



- Flip the seat frame up to gain access to the seat frame adjustment cable connector.
- Unclip the seat frame adjustment cable connector <A> from the seat frame (if equipped).

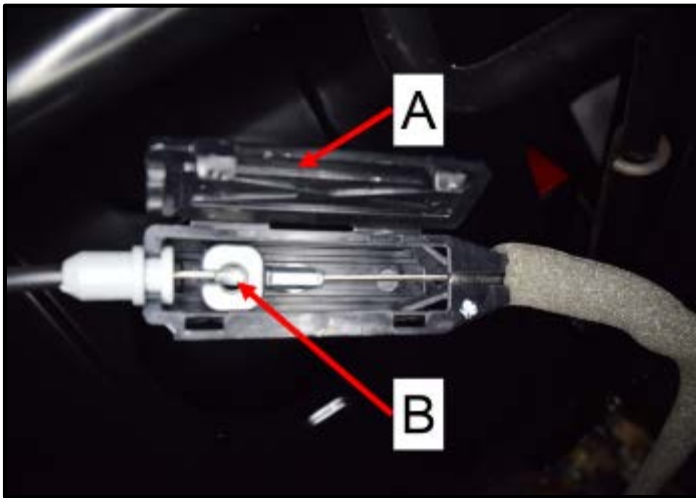

- Open the seat frame adjustment cable connector cover <A> using a small screwdriver or pick tool.
- Remove the cable from the adjustment cable cover and disconnect at the junction (if equipped).

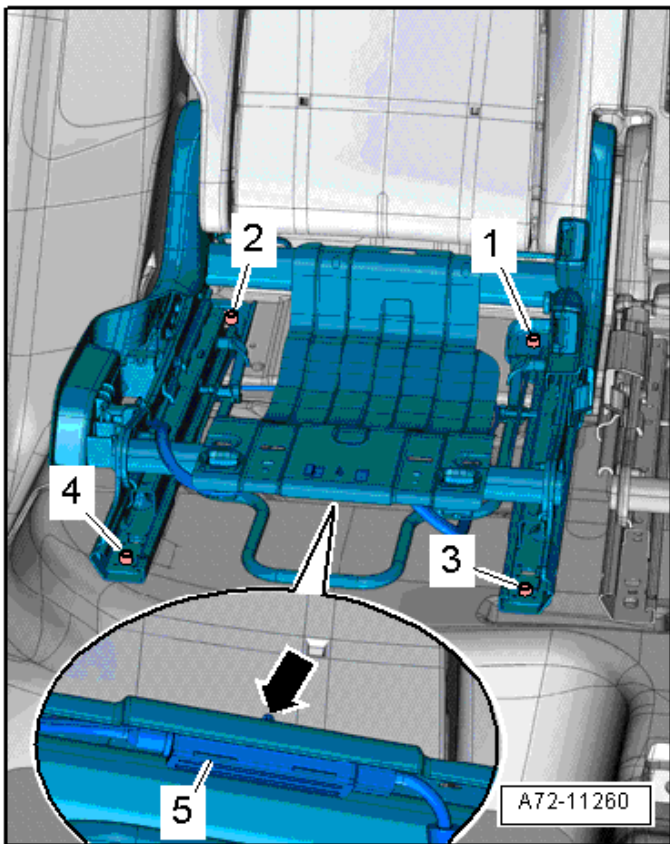

- Remove the right rear seat frame assembly from the vehicle.

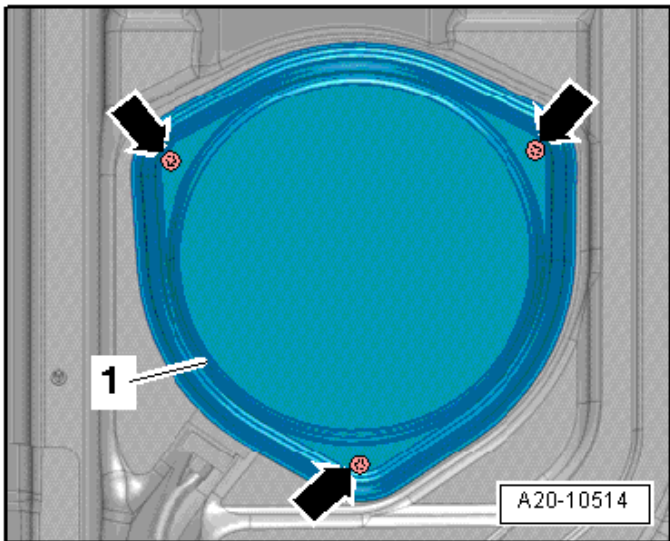

- Remove the fuel pump flange cover <1> by removing the three screws <arrows>.



- Clean top of fuel pump with suitable plastic cleaner.

! NOTE

Use a suitable cloth to apply the plastic cleaner; do not spray the plastic cleaner directly onto the flange.

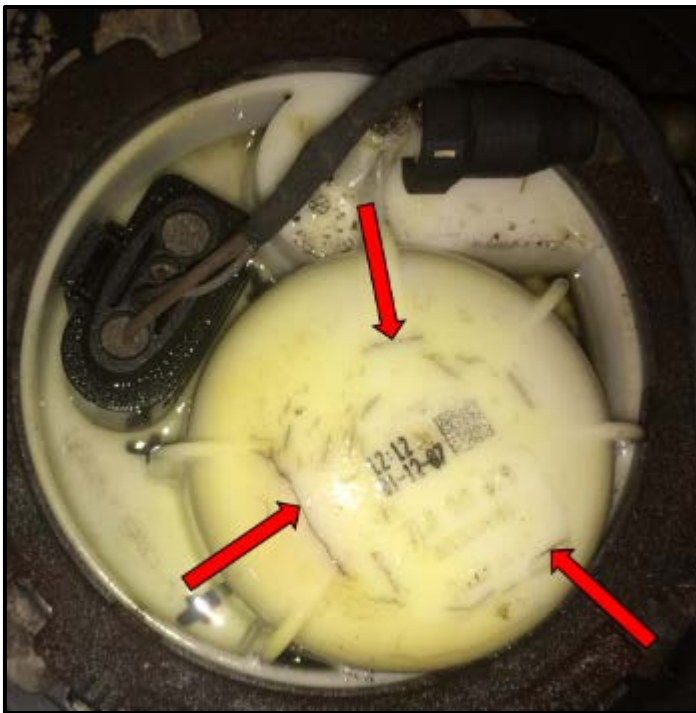

- If there is a visible presence of leaking fuel;
 - **Take photos of the flange clearly showing the leak to attach to the ATA WEB Ticket.**
 - **Continue to Section G and Replace the Fuel Filter Flange and install the protective film.**
 - **All others continue to the next step.**

! NOTE

The fuel filter flange for the Q7 is not on technical block.



- If there are no signs of leaking present, but there **ARE** cracks <circle> and/or yellow discoloration present;
 - **Take photos of the flange clearly showing the cracks to attach to the ATA WEB Ticket.**
 - **Continue to Section G and Replace the Fuel Filter Flange and install the protective film.**
 - **All others continue to the next step.**

! NOTE

The fuel filter flange for the Q7 is not on technical block.



- If there are **NO** cracks, leaks, and/or yellow discoloration present;
 - **Continue to Section F and install the protective film and reinstall the seat frame.**

Section F – Repair Procedure, Installing protective film on Audi Q5 (criteria 8R)



- Apply protective film as shown. Start application from the center and work the protective film towards the outside edges of the fuel pump flange taking care to eliminate air gaps or bubbles under the film.
- Use care when applying protective film so that no dust or dirt comes in contact with the adhesion side of the film.

! NOTE

The fuel pump flange must be fully installed (with the locking ring in place) when the protective film is applied to ensure that part of the protective film does not get trapped between the top section of the fuel pump flange and the locking ring.

Part Number	Part Description
8R0863385	Protective Film

- Reinstall the fuel pump cover <1> by installing and tightening the three screws <arrows>.

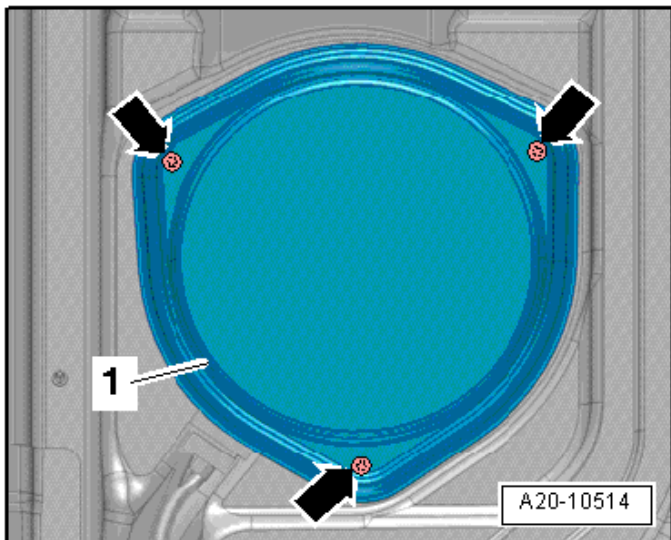

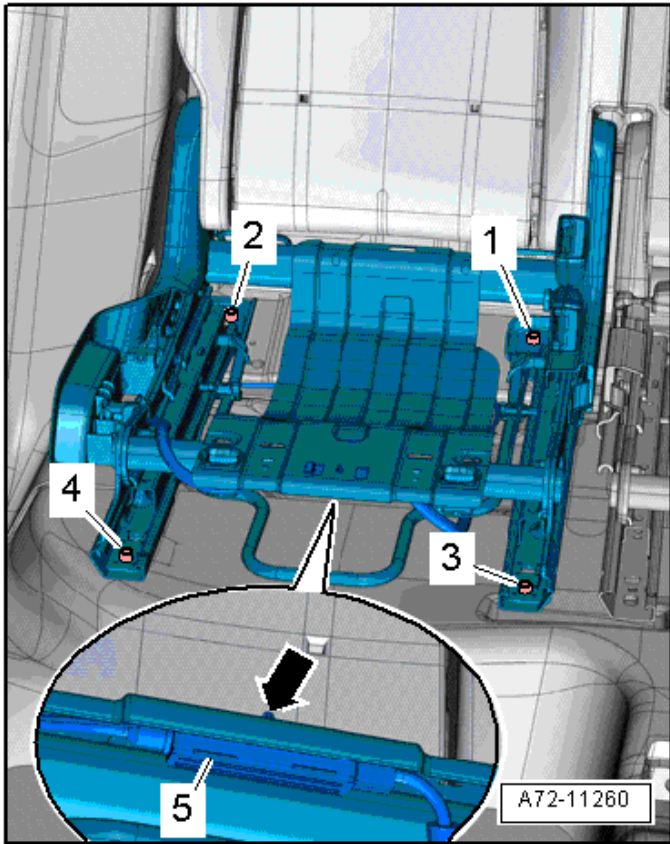

- Reinstall the seat frame.

i TIP
<ul style="list-style-type: none"> • Start bolt <1> by hand <u>first</u>. • The bolt holes in the seat frame for the other three bolts are elongated. Bolt hole <1> is not elongated. This will reduce any chance of cross threading a bolt.

- Torque the seat frame mounting bolts <1, 2, 3, and 4> to 50 Nm.

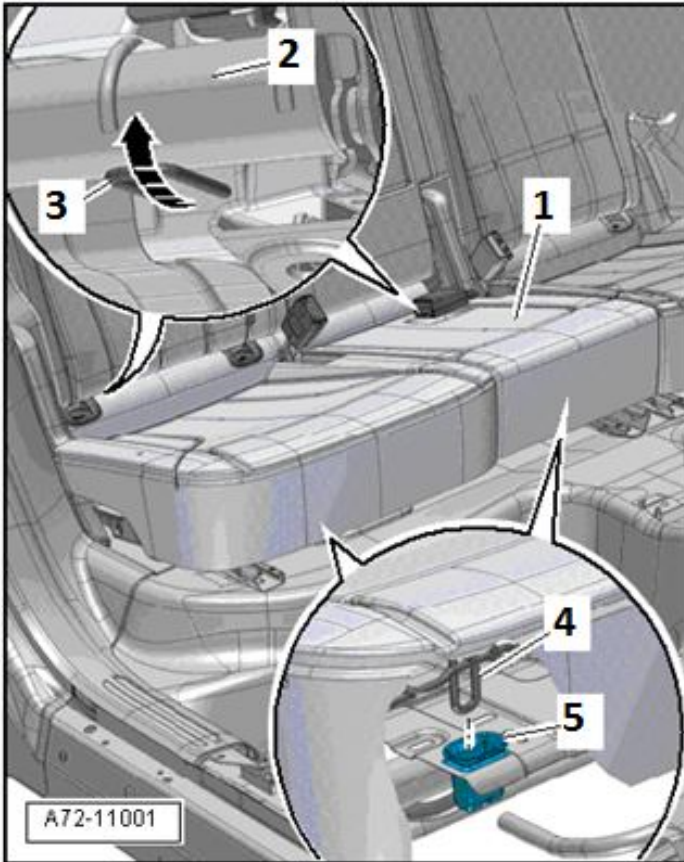

- If the seat cushion mounting grommets <5> remained in the seat frame and the mounting tabs are not damaged, they do not require replacement.
- If the seat cushion mounting grommets <5> are damaged, the seat cushion is loose in the grommets after installation or the grommets stayed attached to the seat cushion, they will require replacement.

- Remove the mounting grommets <5> from the chassis.
- Check the seat frame and chassis floor near the mounting plates for any deformation, and align it if necessary.
- Insert new mounting grommets into the chassis in the position shown <5>.

Part Number	Part Description
8E5886373	Grommet

- Verify proper alignment of the seat frame hooks <4> into the grommets <5>.
- Press the mounting hooks <4> into the grommets <5> until you hear them click into place.

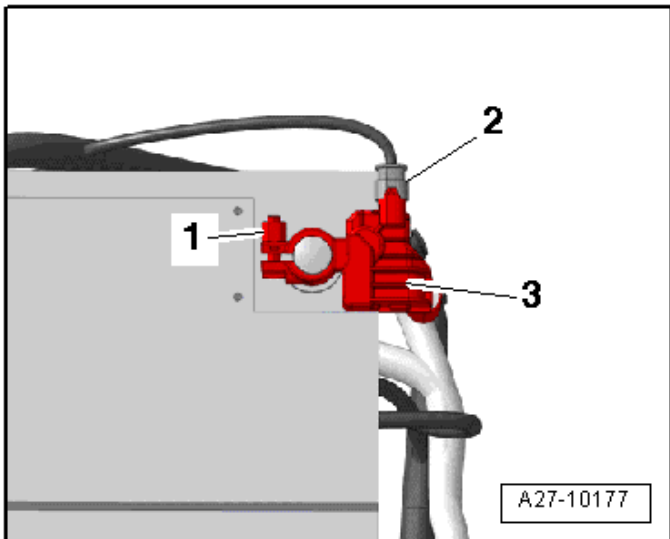

- Disconnect the connector <2> from the Battery Monitoring Control Module -J367- <3>.
- Connect the battery ground cable terminal by hand to the battery negative terminal and tighten the nut <1> to 5 Nm.
- Reconnect the connector to the Battery Monitoring Control Module -J367- <2>.

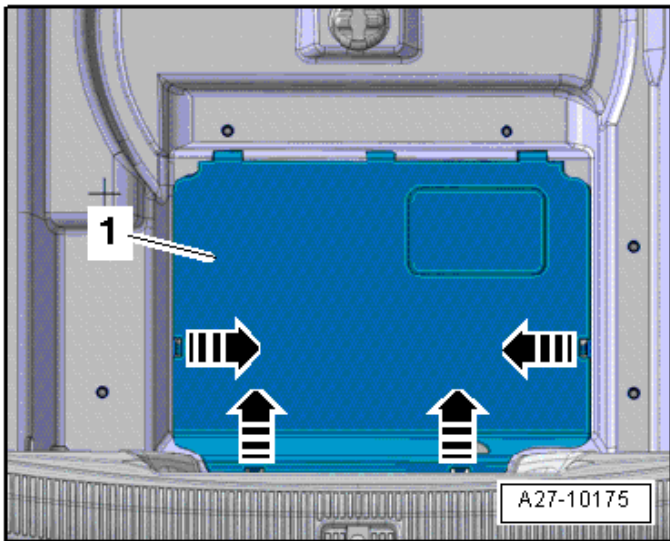

- Close access cover <1> and secure clips <arrows>.
- Check DTC memories of all control modules and erase any under voltage DTCs using the Vehicle Diagnostic Tester.

NOTE

After connecting the power supply, the ABS warning lamp may only go out after the vehicle has been driven a few yards.

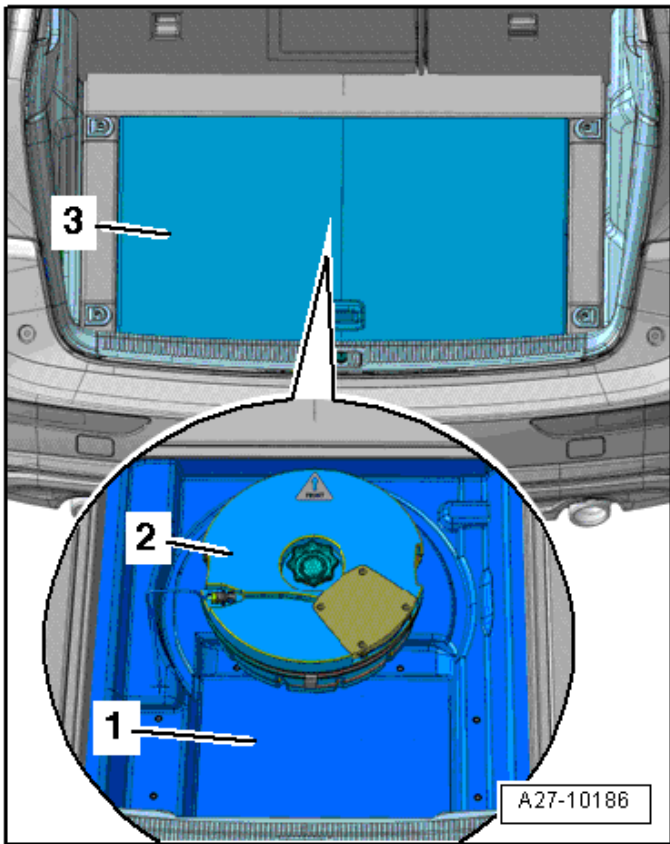

- If equipped, reinstall the subwoofer <2>.
- Reinstall the dirt tray (if equipped), and reinstall the carpeting <1>.
- Reinstall the luggage compartment floor covering <3>.



- Turn on the ignition.
- Cycle the ignition four to five times to prime the fuel system and verify there are no DTCs present and no warning lamps illuminated.
- Start the vehicle to verify fuel system functionality. Make sure to check for any fuel leaks before delivering the vehicle to the customer.
- Check the vehicle fuel level displayed on the instrument cluster <A>.
- Refer to the vehicle fuel level on the repair order and verify the proper operation of the fuel level sensor, and that the correct amount of fuel has been returned to the vehicle from the Fuel Extracting Device -VAS5190A- (if removed).
- Reset customer convenience basic settings (i.e. one touch windows, instrument cluster clock, etc.).
- Repair Complete - **Proceed to Section H.**

Section G – Repair Procedure, Replacing Fuel Filter Flange on Audi Q5 (criteria 8R)

NOTE

- After replacement of the fuel filter flange, application of the Protective Film is required. Follow the work instructions for additional details.
- If the electrical harness requires repair, refer to ETKA and ELSA for additional required parts and repair information.
- When replacing the fuel filter flange, an ATA WEB ticket <arrow> will need to be created to order the fuel filter flange.

Technical Assistance

Create Ticket

Ticket Information

Concern Type: Select a concern type Technician Email: Technician Code: 200100

Vehicle Information

VIN: (VWUUPP7F32A00001) Make: Model: Model Year: Mileage: Region Code: Technician Code: 1000

Contact Center: CT call center (CT call wait for web response (up to 2 business hours))

- When creating the WEB ticket, be sure to enter a contact phone number at the bottom of the Technician's Questionnaire.



- If the fuel filter flange was leaking fuel, inspect the wiring harness connector carefully for damage due to fuel wicking into the weather pack seals.
- If damage to the weather pack seal and/or wiring harness is discovered, be sure to order the appropriate wiring and connector to correctly repair the damaged harness.

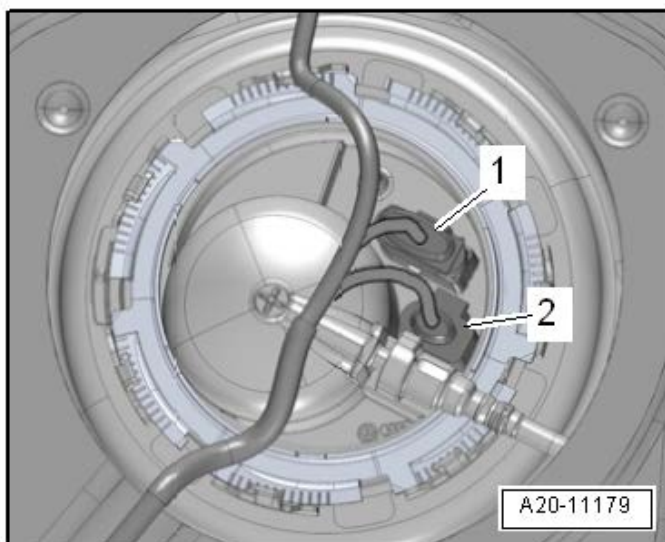

- Clean and/or vacuum the area around the fuel pump opening to ensure no debris falls into the fuel tank during the repair.
- Disconnect the electrical connectors on the top of the fuel pump assembly <1 and 2>.

CAUTION

Proper safety equipment is required. Wear safety goggles and protective gloves when working with gasoline, or any other fuel.

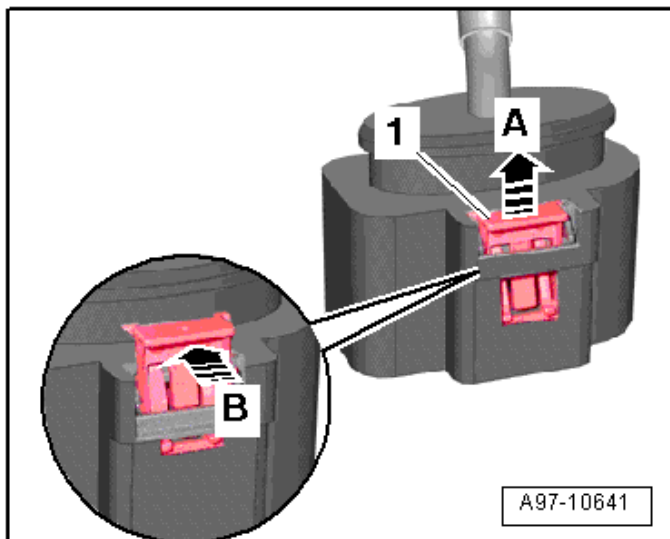

- To disconnect the connector, pull up <arrow A> on the red locking tab <1>, then depress the tab inward following the direction of the <arrow B>.
- If the fuel filter flange was cracked and leaking, inspect the electrical connector for any potential damage to the sealing rings, wires, or contacts.



! NOTE

Due to clearance issues between the locking tab and the body of flange, a small pick tool can be used to aid in removal of the connector.

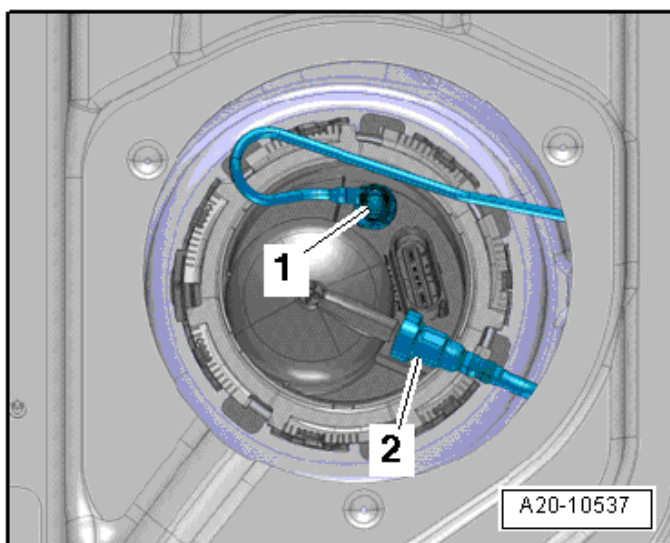

- Remove the fuel line connector <2> from the locking flange by squeezing the release tab between the finger and thumb, pushing in on the connector, and then pulling the connector off.

! NOTE

- Do not use pliers or other tools on the fuel line connector or damage to the connector may occur.
- Damage to the fuel line connector due to improper removal/installation may cause the connector to not fasten securely upon reinstallation, causing a leak.
- A damaged fuel line connector requires replacement of the fuel line.
- Consequential damage to the fuel line connector due to improper removal/installation is not covered under this campaign.

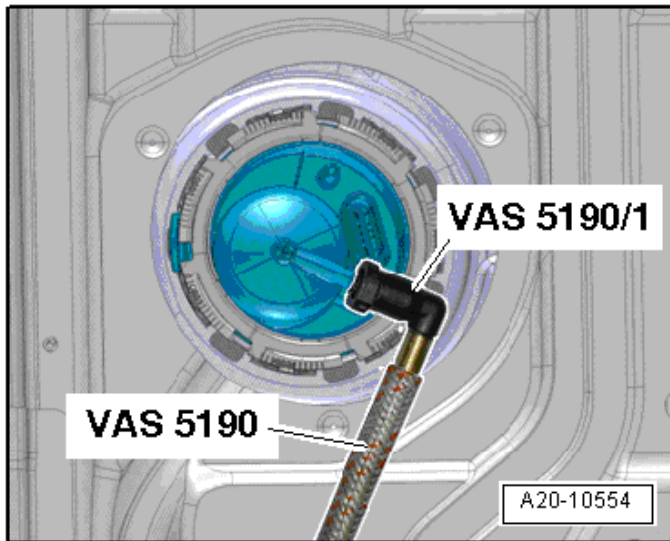

If required based on fuel level, remove fuel from the tank:

- Connect the suction hose to the -VAS5190/1- on the sealing flange supply connection.
- Extract fuel until the vehicle retains approximately $\frac{1}{4}$ of a tank.
- Disconnect the -VAS5190/1- on the sealing flange by pressing the release button.
- Remove the -VAS5190/1- suction hose and re-install the tip.

NOTE

Accurately record the amount of fuel in liters removed from the vehicle using the sightglass measurement viewport on the side of the -VAS 5190- Fuel Extraction Unit. It is required to return to the fuel tank precisely the amount of fuel removed from the fuel tank. Failure to do so may result in fuel sending unit faults.



WARNING

There is a risk of fuel leaking out from the filled fuel filter flange. Lay cloths, rags, or other absorbent material around the fuel filter flange opening to catch the leaking fuel.

CAUTION

Dispose of all absorbent material contaminated with gasoline or any other fuel in accordance with Local and Federal guidelines.

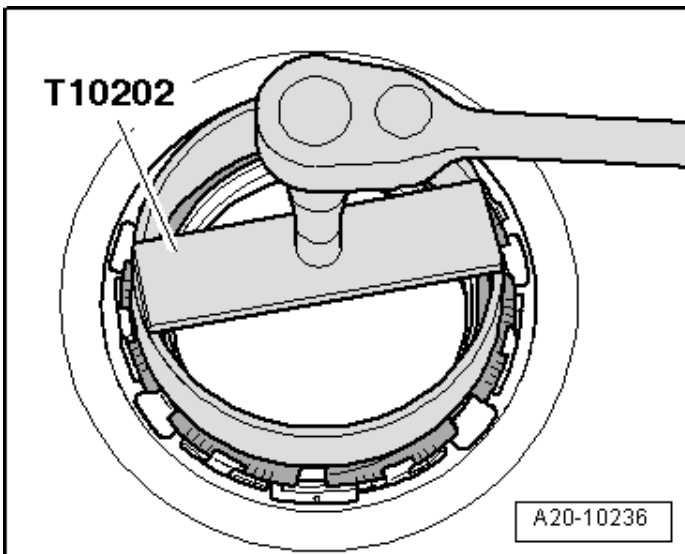

- Using special tool -T10202-, remove the fuel pump flange lock ring by turning counterclockwise.

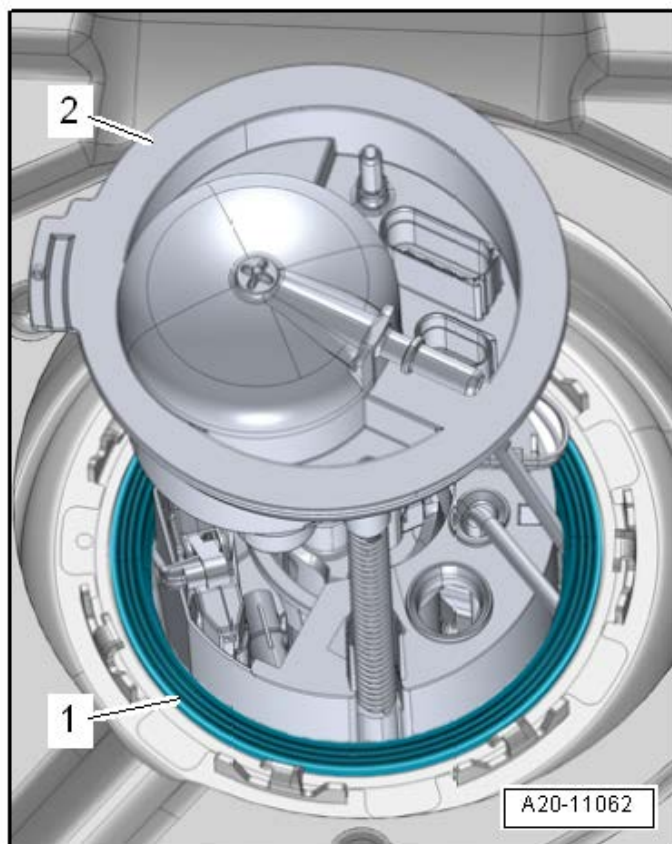

- Pull the fuel filter/sealing flange <2> out of the fuel tank slightly and remove the seal <1> for the sealing flange.
- Pull the sealing flange with the fuel line and the wires as far as possible out of the opening in the fuel tank.
- Turn and tilt the fuel delivery unit with the fuel level sensor and remove through the opening in the fuel tank.

! NOTE

Be careful not to bend the floater arm on the Fuel Level Sensor when removing the fuel delivery unit.

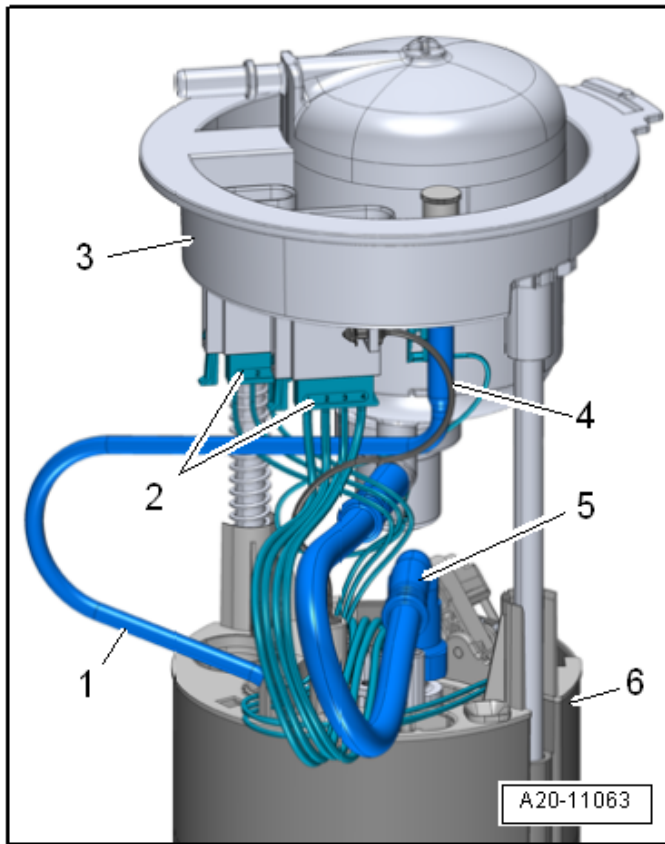

- Disconnect the connectors <2>.
- On vehicles with an auxiliary heater, disengage the fuel line <1> to the metering pump.
- Press the release button and remove the fuel line <5>.
- Disengage the assembly aid <4> on the locking flange.
- Remove the sealing flange <3> from the fuel delivery unit <6>.
- Install new fuel filter with flange <3>.

Part Number	Part Description
8R0919679D	Fuel filter with flange (3.0L – PR # 1A2 only)
1J0919133B	Seal Ring
-OR-	
8R0919679E	Fuel filter with flange (2.0L – PR # 1A4 only)
1J0919133B	Seal Ring

- Reinstall assembly aid <4>.
- Reinstall fuel line <5>.
- On vehicles with an auxiliary heater, reinstall the fuel line <1> to the metering pump.
- Connect connectors <2>.
- Ensure the ground wire <1> on the fuel pressure regulator and the sealing flange is securely attached <arrows>.

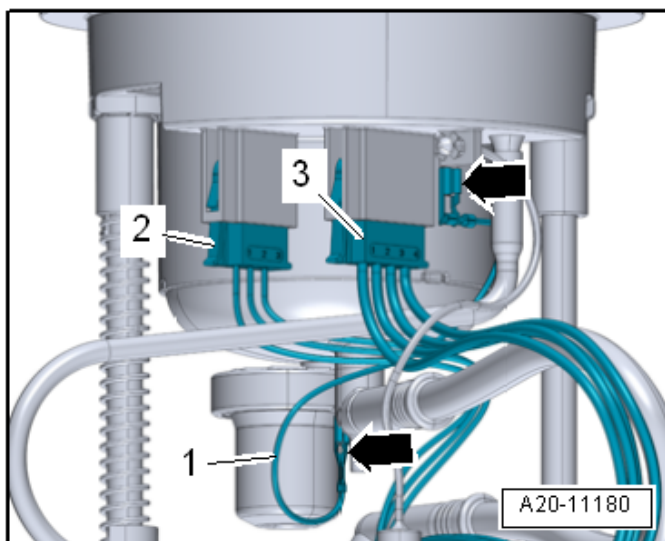

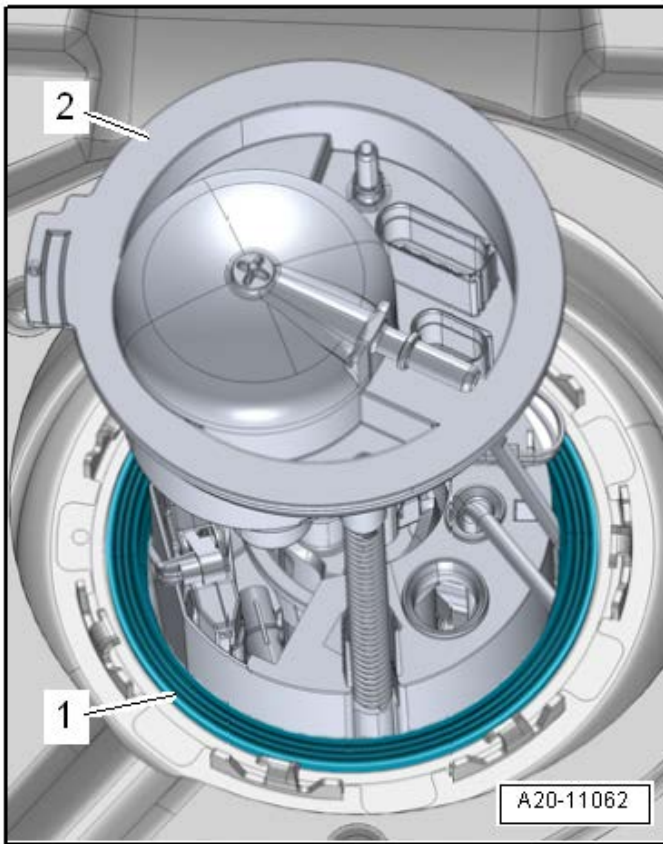

- Carefully reinsert the fuel delivery unit <2> into the fuel tank.
- Install the new sealing flange seal <1> over the fuel filter flange <2> stretched and dry.

NOTE

- Be careful not to bend the floater arm on the Fuel Level Sensor when reinstalling the fuel delivery unit.
- Route the floater arm carefully into the baffle in the fuel tank.
- Make sure all fuel lines inside the fuel tank are routed correctly and do not interfere with the travel of the fuel sending unit floater arm.

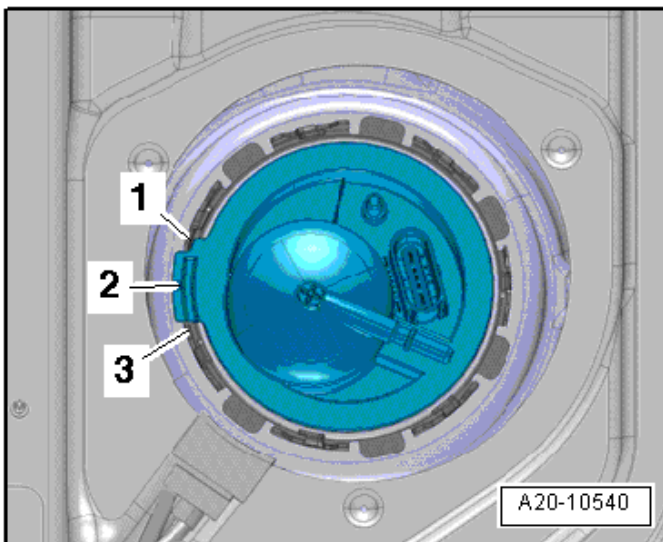

- Move the fuel pump flange into the installation position.

NOTE

The tab <2> on the sealing flange faces toward the rear of the vehicle and must be between the tabs <1> and <3> on the fuel tank.

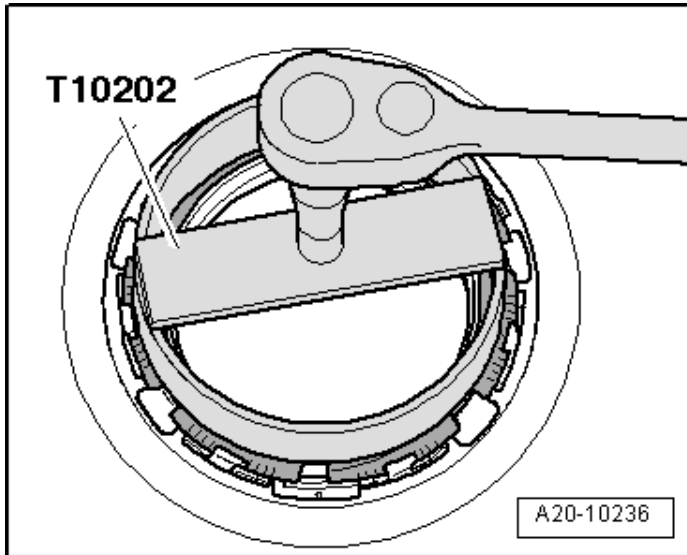

- Tighten the locking ring using the Fuel Sending Unit Wrench -T10202-. Torque the locking flange to 110 Nm.

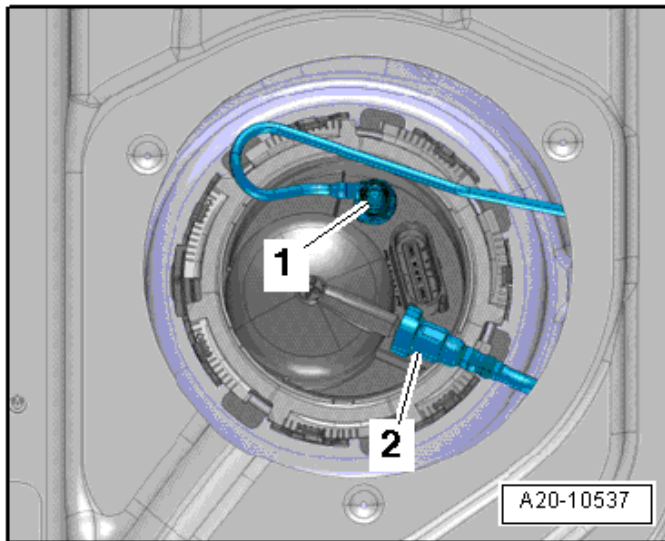

- Connect the fuel line <2>.
- Push the connector into the fuel filter flange until you hear an audible click, then pull gently on the fuel line connector to verify the connection to the fuel filter flange.

NOTE
The fuel heater line <1> is not applicable on most vehicles.

WARNING
You must install the Quick coupling piece cap in the next step onto the nipple located at the fuel heater line connection <1> if the fuel heating line is not applicable, or you will develop a fuel leak.



- Install the Quick coupling piece cap <A> to the top of the fuel filter flange until you hear an audible click.
- Pull gently on the Quick coupling piece cap <A> to verify connection to the fuel filter flange.

Part Number	Part Description
8E0201263A	Quick coupling piece cap

WARNING
There is a risk of fuel leaking out of the fuel line heater connection <A> if the Quick coupling piece cap is not installed. Verify that the Quick coupling piece cap is connected or the vehicle may leak fuel from the fuel line heater nipple.



- If required, repair the wiring harness connector, wiring, and weather pack seals before reconnecting the connector to the fuel filter flange.

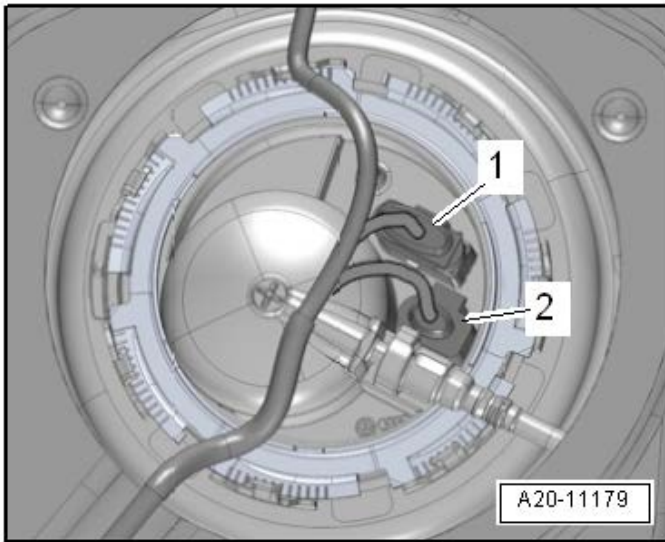

- Reinstall the electrical connectors <1 and 2> until you hear an audible click.
- Pull gently on the connector to verify connection to the fuel filter flange.

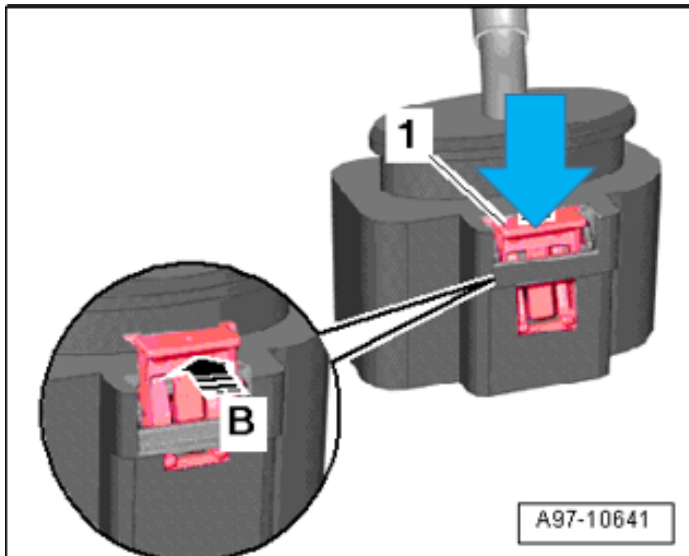

- Be sure to properly engage the red locking tab <1> by pressing down <arrow> after properly securing the connector.

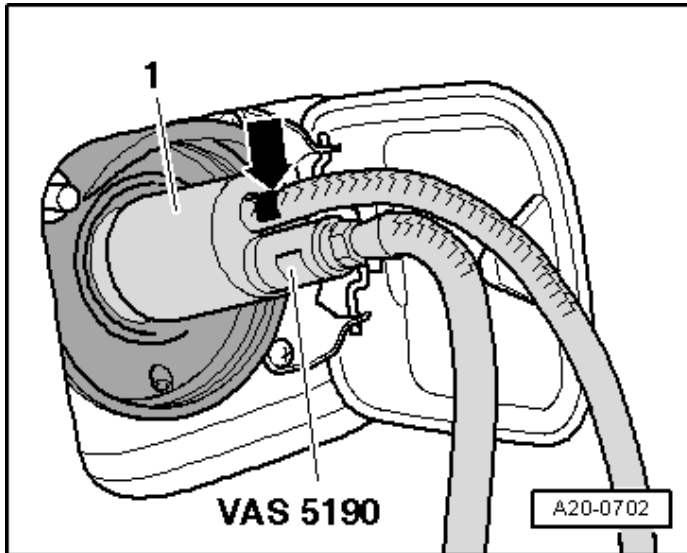

- Dispense recovered fuel contained in the -VAS 5190- Fuel Extracting Device back into the vehicle fuel tank.

CAUTION

Refer to the previously recorded fuel measurement obtained from the -VAS 5190- Fuel Extraction Unit sightglass. Be certain to refill the vehicle fuel tank with the same amount of fuel that was originally extracted from the vehicle or fuel sending unit faults may occur.

- **Continue to Section F to install the protective film and reinstall the seat frame.**

Section H – Campaign Completion Stamp

I certify that this campaign has been performed in strict accordance with the applicable Audi repair procedure.

SAGA Code: _____

Technician: _____

Date: _____

Item#: AUD4927ENG

-OR-

Je certifie que cette campagne de rappel a été exécutée suivant les strictes directives de réparation d'Audi

Code de SAGA: _____

Technicien: _____

Date: _____

Item # AUD4927FRE

- Once the campaign has been completed, the technician should stamp the repair order.
- Stamps are available for ordering through the Compliance Label Ordering Portal.
- **Proceed to Section I.**

Section I - Parts Return/Disposal

Properly store (retain), destroy or dispose of removed parts in accordance with all state/province and local requirements, unless otherwise indicated and/or requested through the Warranty Parts Portal (WPP).

Appendix A – Warning and Safety Precautions

WARNING

Note the Following When Working on the Fuel System:

- There is a risk of injury because the fuel is under very high pressure.
- Fuel pressure in high pressure pipe can be up to 120 bar (1740 psi)! Always follow the safety precautions when reducing the pressure in the high pressure area.
- The fuel supply line is under pressure. To prevent injuries and skin contact, wear protective goggles and protective clothing. Wrap a clean cloth around the connection before loosening hose connections. Remove the hose connection carefully to release the pressure.
- Fuel coming into contact with skin poses a health risk.
- Do not let fuel come in contact with bare skin. Wear fuel-resistant gloves.
- Leaking fuel poses a risk of burns.
- For safety reasons, switch off the current to the fuel pump before opening the fuel system. Otherwise, the fuel pump will activate when the driver door is opened.
- Disconnect the power supply by removing the fuse for the Fuel Pump Control Module / fuel delivery unit, or by disconnecting the battery.
- Danger of explosion due to cell phones. Keep cell phones out of reach in the work space area.

WARNING

General Safety Precautions when Working with Pyrotechnic Components:

- Pyrotechnic components always contain propellant that generates a gas during combustion. In some components, there is also a supply of pressurized gas to ensure this gas is generated
- This pressurized gas is stored under high pressure in a compressed gas container. Pyrotechnic components are triggered by electrical/mechanical igniters.
- Only trained personnel should perform testing, assembly and servicing work. Airbags do not have a replacement interval.
- Never check with test lamps, voltmeter or ohmmeters.
- Only check pyrotechnic components when they are installed in the vehicle using vehicle diagnosis, testing and information systems approved by the manufacturer.
- When working on pyrotechnic components and the airbag control module, disconnect the battery ground strap while the ignition is switched off. Then cover the negative terminal.
- Wait 10 seconds after disconnecting the battery.
- The ignition must be switched off when connecting the battery. There should not be anyone inside the vehicle when doing this.
- Exception: vehicles with batteries in the passenger compartment. In this case, stay outside the range of the airbags and seat belts.
- Wash your hands after touching ignited pyrotechnic components from the restraint system.
- Do not open or repair pyrotechnic components. Use only new components to reduce the risk of injury.
- Do not install pyrotechnic components that have fallen onto a hard surface or show signs of damage.
- Discharge static electricity before handling pyrotechnic components, for example before disconnecting the electrical connector. This can be done by touching grounded metal objects such as the door striker pin.
- Install pyrotechnic components immediately after removing them from their transport packaging. If you must stop working, store the pyrotechnic component in its original transport packaging.

- Do not leave pyrotechnic components lying in the open unattended.
- Do not treat pyrotechnic components with grease, cleaning solutions or similar products.
- Do not expose pyrotechnic components to temperatures above 100 °C, even for brief periods of time.