

Product Safety Recall

N202322230 Seat Belt May Not Be Properly Attached



Release Date: December 2020

Revision: 00

Attention: It is a violation of Federal law for a dealer to deliver a new motor vehicle or any new or used item of motor vehicle equipment (including a tire) covered by this notification under a sale or lease until the defect or noncompliance is remedied.

All involved vehicles that are in dealer inventory must be held and not delivered to customers, dealer traded, or used for demonstration purposes until the repair contained in this bulletin has been performed on the vehicle.

There are only 3 vehicles involved in this recall, please see below:

1G1FZ6S00L4144945
1G1FW6S0XL4144914
1G1FZ6S02L4145207

Make	Model	Model Year		RPO	Description
		From	To		
Chevrolet	Bolt EV	2020	2020		

Involved vehicles are marked “open” on the Investigate Vehicle History screen in GM Global Warranty Management system. This site should always be checked to confirm vehicle involvement prior to beginning any required inspections and/or repairs.

Condition	General Motors has decided that a defect which relates to motor vehicle safety exists in certain 2020 model year Chevrolet Bolt EV vehicles. In these vehicles, the wrong seat-belt bolt may have been used at one or more fastening locations to secure the seat belt to the vehicle. If an incorrect bolt was used, the seat belt may not be properly attached to the vehicle. If a seat belt assembly is not properly attached to the vehicle, the seat belt may not properly restrain an occupant, increasing risk of occupant injury in a crash.
Correction	Dealers will replace bolts at suspect seat-belt attachment locations.

Parts

Quantity	Part Name	Part No.
1	Bolt	11611776

Important: Due to limited initial parts availability, parts should only be ordered when a Dealer has a vehicle with a VIN that is subject to this Recall. If the VIN is subject to this Recall, its recall status in IVH should be listed as “open.” We have also attached information below to access involved VINs for your convenience.

Reminder: Parts may be removed from Retail Inventory Management (RIM). Dealers should review the affected parts to confirm RIM managed status. Parts may have quantity limiters in effect.

There are only 3 vehicles involved in this recall. DO NOT ORDER BOLTS FOR SHELF STOCK.

Warranty Information

Labor Operation	Description	Labor Time	Trans. Type	Net Item
9105521	Replace Right Front Row Seat Belt Retractor Mounting Bolt	0.6	ZFAT	N/A

Service Procedure

NOTE: There are only 3 vehicles involved in this recall, please see below:

1G1FZ6S00L4144945
1G1FW6S0XL4144914
1G1FZ6S02L4145207

NOTE: The bolt being removed from the vehicle may not have cut the proper threads in the nut when the vehicle was manufactured. If this occurred, expect to feel resistance for the complete bolt length when removing the bolt. When the new bolt is being installed in an unthreaded nut, there will be resistance as the self-threading bolt threads the nut. There will be an initial resistance while the thread is being cut, followed by a reduction in resistance. This is an expected condition. Continue tightening the bolt until the retractor or belt bracket is secured. To complete the installation, tighten the bolt to the proper torque specification.

Product Safety Recall

N202322230 Seat Belt May Not Be Properly Attached



1. Remove the right center pillar lower trim panel. It is not necessary to disconnect the seat belt from any attachment points. Refer to *Center Pillar Lower Trim Panel Replacement* in SI.

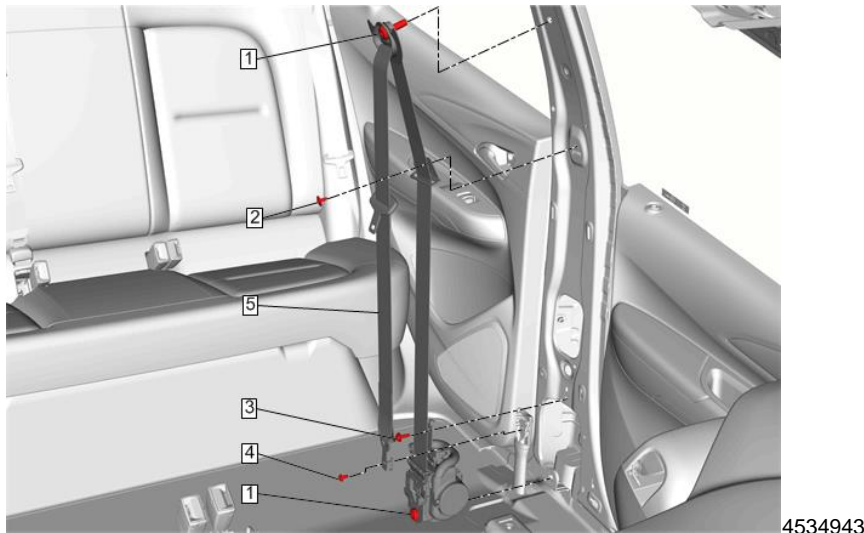

Note: The LH side is shown for reference purposes only.

2. Remove and discard the lower retractor bolt (1).
3. Install the new retractor mounting bolt. Refer to the note above for installation details. Tighten the new service bolt to 45 N.m (33 lb. ft).
4. Reinstall the center pillar lower trim panel. Refer to *Center Pillar Lower Trim Panel Replacement* in SI.

Dealer Responsibility – For USA & Export (USA States, Territories, and Possessions)

It is a violation of Federal law for a dealer to deliver a new motor vehicle or any new or used item of motor vehicle equipment (including a tire) covered by this notification under a sale or lease until the defect or noncompliance is remedied.

The US National Traffic and Motor Vehicle Safety Act provides that each vehicle that is subject to a recall of this type must be adequately repaired within a reasonable time after the customer has tendered it for repair. A failure to repair within sixty days after tender of a vehicle is prima facie evidence of failure to repair within a reasonable time. If the condition is not adequately repaired within a reasonable time, the customer may be entitled to an identical or reasonably equivalent vehicle at no charge or to a refund of the purchase price less a reasonable allowance for depreciation. To avoid having to provide these burdensome remedies, every effort must be made to promptly schedule an appointment with each customer and to repair their vehicle as soon as possible. In the recall notification letters, customers are told how to contact the US National Highway Traffic Safety Administration if the recall is not completed within a reasonable time.

Dealer Responsibility – All

All new, used, GM Certified Used, courtesy transportation vehicles, dealer shuttle vehicles, etc. in dealers' possession and subject to this recall must be held and inspected/repared per the service procedure of this bulletin before customers take possession of these vehicles. Involved vehicles must be held and not delivered to customers, dealer-traded, released to auction, used for demonstration, or any other purpose.

All GM Certified Used vehicles currently in the dealers' inventory within the Certified Pre-Owned Inventory System (CPOIS) will be de-certified and must be held and remedied per the service procedure in this bulletin. Upon submitting an accepted/paid warranty transaction in the Global Warranty Management (GWM) system, the vehicle can be re-certified for sale within the CPOIS system, or once again be used in the CTP program.

Dealers are to service all vehicles subject to this recall at no charge to customers, regardless of mileage, age of vehicle, or ownership, from this time forward.

Customers who have recently purchased vehicles sold from your vehicle inventory, and for which there is no customer information indicated on the dealer listing, are to be contacted by the dealer. Arrangements are to be made to make the required correction according to the instructions contained in this bulletin. Recall follow-up cards should not be used for this purpose, since the customer may not as yet have received the notification letter.

Product Safety Recall

N202322230 Seat Belt May Not Be Properly Attached



In summary, whenever a vehicle subject to this field action enters your vehicle inventory you must take the steps necessary to ensure the program correction has been made before selling the vehicle. In addition, for vehicles entering your facility for service, you are required to ensure the customer is aware of the open field action and make every reasonable effort to implement the program correction as set forth in this bulletin prior to releasing the vehicle.

Dealer Reports

For dealers with involved vehicles, a listing has been prepared and will be available through GM GlobalConnect Maxis Field Action Reports or sent directly to export dealers. The Inventory tab of the dealer reports will contain VINs that apply to this recall. This information is intended to assist dealers with the **PROMPT COMPLETION** of these vehicles. The Customer In-Service tab will contain customer names and addresses from Motor Vehicle Registration Records. The use of such motor vehicle registration data for any purpose other than follow-up necessary to complete this recall may be a violation of law in several states.

Courtesy Transportation – For USA & Canada

Courtesy transportation is available for customers whose vehicles are involved in a product program and still within the warranty coverage period. See General Motors Service Policies and Procedures Manual for courtesy transportation program details.

Customer Notification

USA & Canada - General Motors will notify customers of this recall on their vehicle.

GM bulletins are intended for use by professional technicians, NOT a "do-it-yourselfer". They are written to inform these technicians of conditions that may occur on some vehicles, or to provide information that could assist in the proper service of a vehicle. Properly trained technicians have the tools, equipment, safety instructions, and know-how to do a job properly and safely. If a condition is described, DO NOT assume that the bulletin applies to your vehicle, or that your vehicle will have that condition. See your dealer for information on whether your vehicle may benefit from the information.



**We Support
Voluntary Technician
Certification**