

Safety Recall: 2007-08 Fit Driveshaft Inspection

Supersedes 21-042, dated April 2, 2021, to revise the information highlighted in **yellow**

AFFECTED VEHICLES

Year	Model	Trim Level	VIN Range
2007-08	Fit (A/T models only)	ALL	Check the iN VIN status for eligibility.

REVISION SUMMARY

Under REPAIR PROCEDURE step 17, a note and images were added.

BACKGROUND

Due to improper manufacturing, the paint on the driveshaft near the dynamic damper may peel and chip over time, exposing the bare metal and potentially causing it to corrode under the dynamic damper. A corroded driveshaft may break during high torque conditions, rendering the vehicle without propulsion, or allowing the vehicle to roll while in Park, which can increase the potential of a crash or injury.

This recall applies only to vehicles with driveshafts that have a dynamic damper. If only one driveshaft has a dynamic damper, do the INSPECTION PROCEDURE on that driveshaft only, and replace only that driveshaft if it fails the inspection.

The affected VIN population for this recall was determined based on information available to Honda at the time the recall was announced. If a customer believes their vehicle should be included in the campaign due to information not available to Honda (either at the time of recall announcement or thereafter), contact your DPSM and have the customer contact American Honda with their concern. For any questions or concerns that customers may have, you may direct them to contact American Honda's Customer Support & Campaign Center at **888-234-2138**.

CUSTOMER NOTIFICATION

Owners of affected vehicles will be sent a notification of this campaign.

Do an iN VIN status inquiry to make sure the vehicle is shown as eligible.

Some vehicles affected by this campaign may be in your new or used vehicle inventory.

Failure to repair a vehicle subject to a recall or campaign may subject your dealership to claims or lawsuits from the customer or anyone else harmed as a result of such failure. Before selling a vehicle in inventory, always check if it is affected by a safety recall by conducting a VIN status inquiry.

CUSTOMER INFORMATION: The information in this bulletin is intended for use only by skilled technicians who have the proper tools, equipment, and training to correctly and safely maintain your vehicle. These procedures should not be attempted by "do-it-yourselfers," and you should not assume this bulletin applies to your vehicle, or that your vehicle has the condition described. To determine whether this information applies, contact an authorized Honda automobile dealer.

CORRECTIVE ACTION

This recall applies only to vehicles with driveshafts that have a dynamic damper. If neither driveshaft has a dynamic damper, this recall does not apply. If only one driveshaft has a dynamic damper, do the INSPECTION PROCEDURE on that driveshaft only, and replace only that driveshaft if it fails the inspection.

This recall applies only to vehicles with driveshafts that have a dynamic damper. If only one driveshaft has a dynamic damper, do the INSPECTION PROCEDURE on that driveshaft only, and replace only that driveshaft if it fails the inspection.

If either driveshaft fails inspection and parts are not available, the vehicle must not be returned to the customer until replacement driveshafts are installed. If the customer needs alternative transportation due to parts shortages, contact your DPSPM and make arrangements for the customer.

Failure to follow the inspection and repair procedure correctly may result in the driveshaft breaking under the dynamic damper. This could render the vehicle without propulsion, or allow the vehicle to roll while in Park. Improper repairs could be subject to debit.

PARTS INFORMATION

Part Name	Part Number	Quantity
Right Driveshaft Assembly Kit (includes right side driveshaft assembly, axle nut, castle nut, and set ring for half-shaft).	06440-SLN-305	1
(Left Driveshaft Assembly Kit (includes left side driveshaft assembly, axle nut, castle nut).	06440-SLN-306	1

REQUIRED MATERIALS

Part Name	Part Number	Quantity
ATF-DW1 (1 bottle will repair 5 vehicles) (A/T only)	08200-9008	1
M-77 Assembly Paste (1 tube will repair 12 vehicles)	08798-9010	1

TOOL INFORMATION

NOTE:

- The tools listed below are required tools that should be in your dealer inventory. Order additional tools only if your tools are damaged and need replacement.
- For the 28 mm Ball Joint Remover, part numbers 07MAC-SL00200, 07MAC-SL00201, or 07MAC-SL0A202 can be used in place of 07MAC-SL00202.

Tool Name	Part Number	Quantity
28 mm Ball Joint Remover	07MAC-SL00202	1
12 mm Ball Joint Thread Protector	07AAF-SDAA100	1

WARRANTY CLAIM INFORMATION

NOTE: If the vehicle has no driveshafts with a dynamic damper, no further action is needed. Please submit a warranty claim for Inspection ONLY, to close out the campaign.

Operation Number	Description	Flat Rate Time	Defect Code	Symptom Code	Template ID	Failed Part Number
2195B3	Inspect both driveshaft assemblies only.	0.3 hr	6DY00	PAV00	A21042A	44306-SLN-L00
2191CB	Replace both driveshaft assemblies (includes inspection, fluid check, and wheel alignment).	1.9 hr	6DY00	PAV00	A21042B	44306-SLN-L00
2191CC	Replace left driveshaft assembly only (includes inspection, fluid check, and wheel alignment).	1.5 hr	6DY00	PAV00	A21042C	44306-SLN-L00
2191CD	Replace right driveshaft assembly only (includes inspection, and wheel alignment).	1.1 hr	6DY00	PAV00	A21042D	44305-SLN-L00

Skill Level: Repair Technician

INSPECTION PROCEDURE

NOTE: This recall applies only to vehicles with driveshafts that have a dynamic damper. If neither driveshaft has a dynamic damper, this recall does not apply. If only one driveshaft has a dynamic damper, do the INSPECTION PROCEDURE on that driveshaft only, and replace only that driveshaft if it fails the inspection.

1. Raise and support the vehicle.
2. Use a clean shop towel to wipe any excess dirt and debris from the driveshafts between the outer joint and the dynamic damper.

NOTE: Paint chips may be sharp and could cut bare hands. Use gloves when wiping the driveshaft.

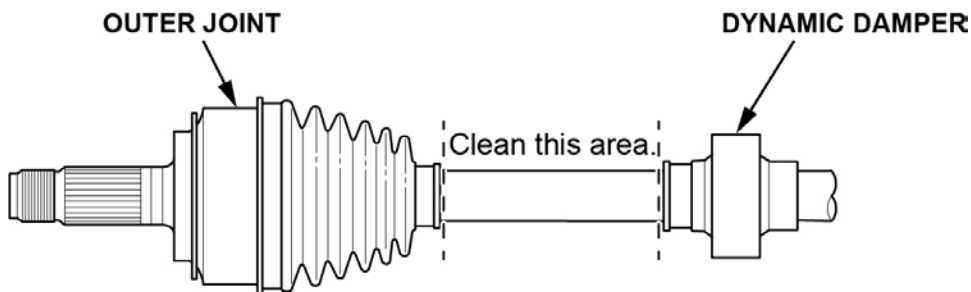

3. Using a ruler and yellow paint marker, measure **40 mm (1-11/16 in)** away from the dynamic damper, and mark the driveshaft with a dot. Click [HERE](#) to view a video on how to do the inspection procedure.

NOTE: Do not scribe or damage the painted surface of the driveshaft. Any replaced driveshafts may be called in for inspection.

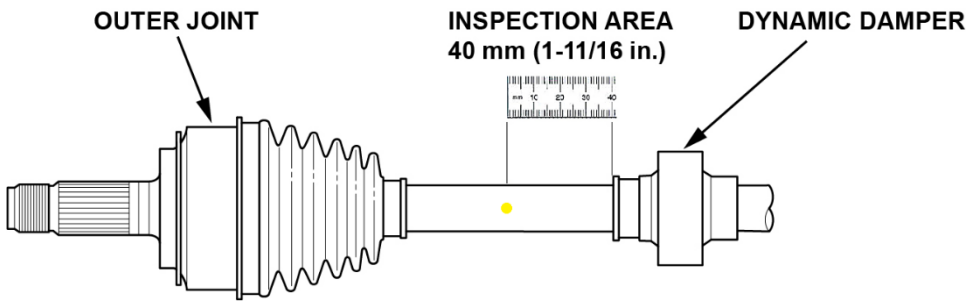

4. Rotate the axle 1/4 turn and repeat the step above **three times** until there are four paint dots on the axle.

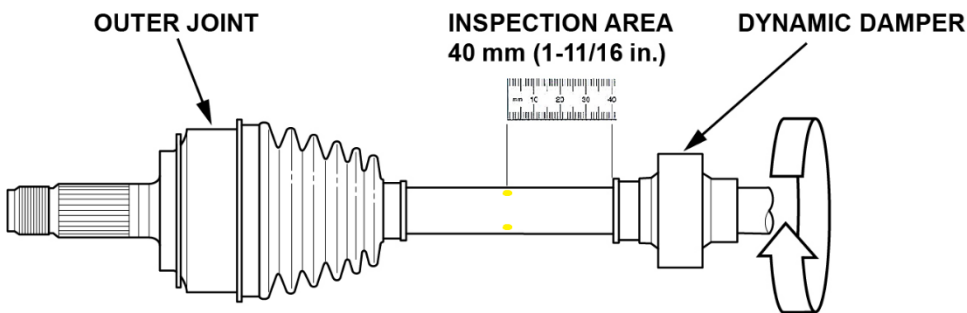

5. Connect the four painted dots around the axle using masking tape.

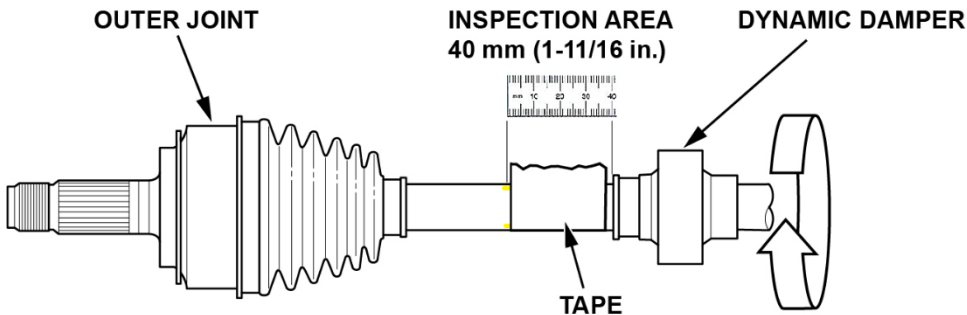

6. Using the masking tape as a guide, trace a line all around the axle using the yellow paint marker. Marking the line accurately is important, especially if there is damage close to or inside the 40 mm line.

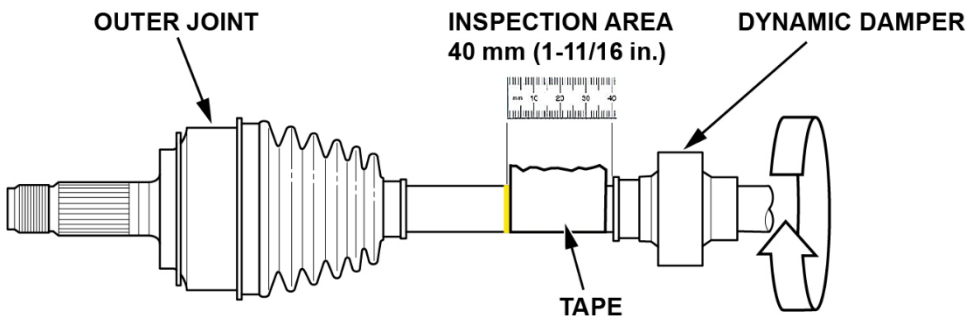

7. Remove the masking tape.

8. Inspect the driveshaft surface between the dynamic damper and the line for peeling paint, cracks, or blisters. Corrosion or paint defects between the outer joint and the yellow line are OK.

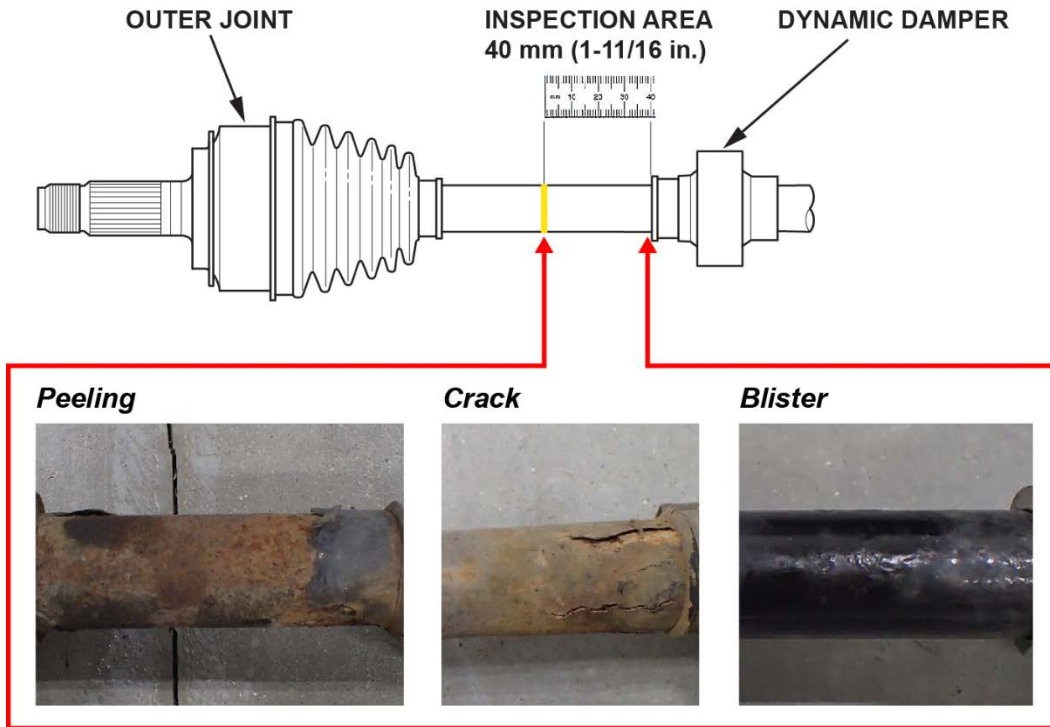

Is there peeling paint, cracks, or blisters on either driveshaft within **40 mm (1-11/16 in)** of the dynamic damper?

Yes - Go to REPAIR PROCEDURE.

No - The driveshafts are OK. Return the vehicle to the customer.

REPAIR PROCEDURE

NOTE: Replace only the affected driveshaft(s) as determined after doing the INSPECTION PROCEDURE.

1. Remove the front wheel of the driveshaft you are replacing.

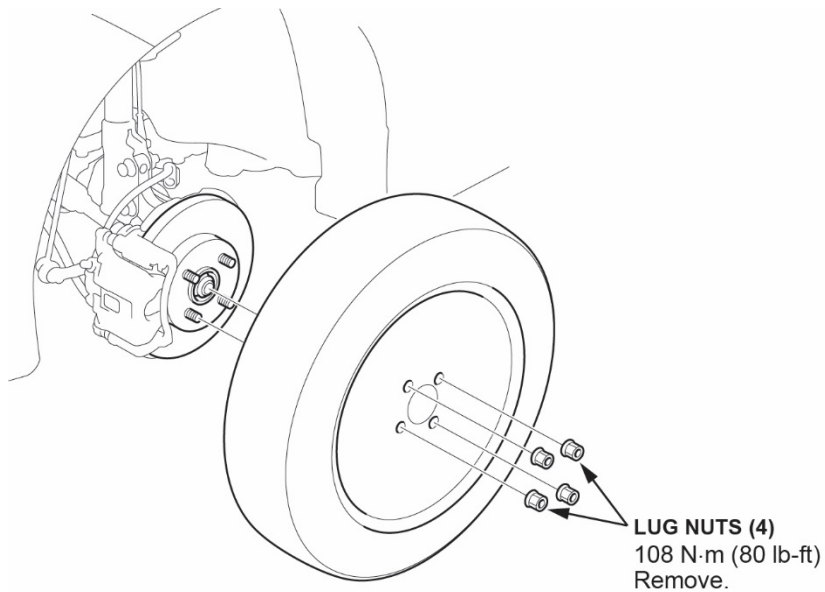

2. Pry up the stake on the spindle nut, then remove it.

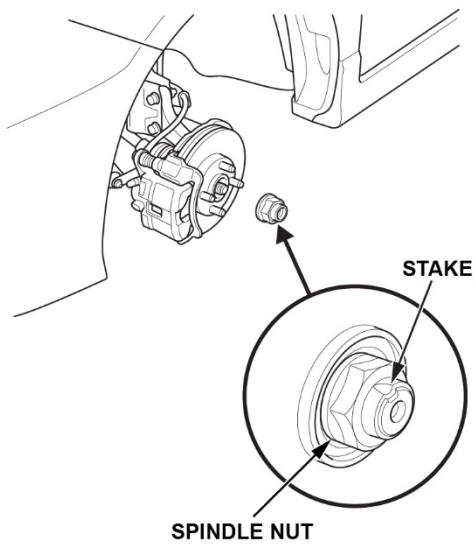

3. Remove the lock pin from the lower arm ball joint, then remove the castle nut.

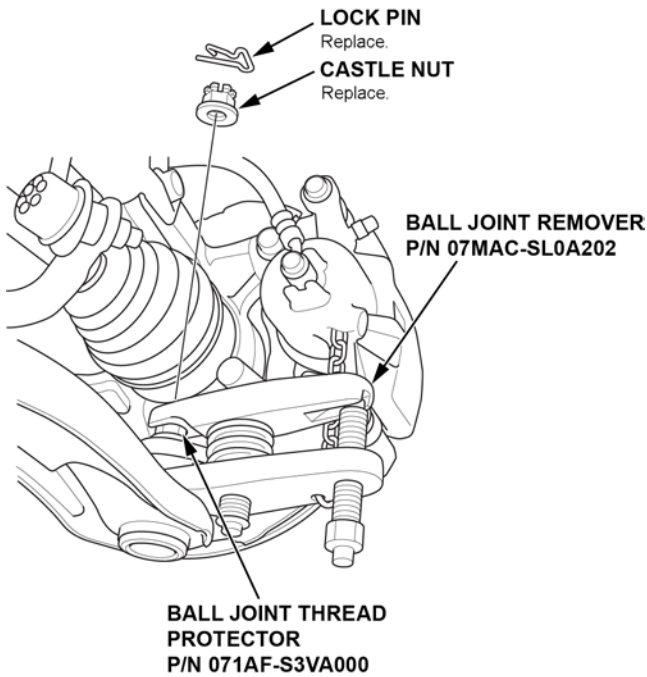

4. Separate the ball joint from the knuckle using the Ball Joint Thread Protector (T/N: 07AAF-SDAA100) and Ball Joint Remover (T/N: 07MAC-SL0A202). Grease the threads and tip of the pressure bolt on the ball joint remover, and make sure the pivot bolt is not parallel to the ball joint remover arms. For additional information on how to use the tools, refer to the service information.

NOTE:

- To avoid damaging the ball joint, install the ball joint thread protector onto the threads of the ball joint.
- Be careful not to damage the ball joint boot when installing the remover.
- Do not force or hammer on the lower arm, or pry between the lower arm and the knuckle to prevent damage.

5. Use a soft-face hammer to separate the outboard joint from the front hub.

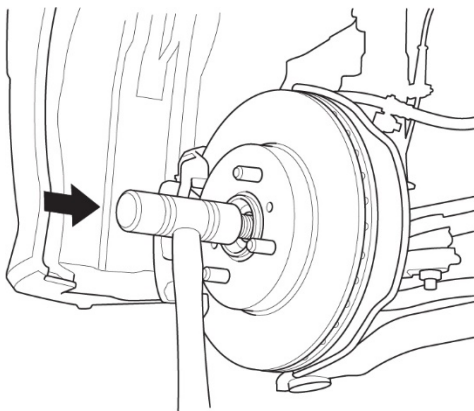

6. Pull the knuckle outward to separate the outboard joint from the front wheel hub.

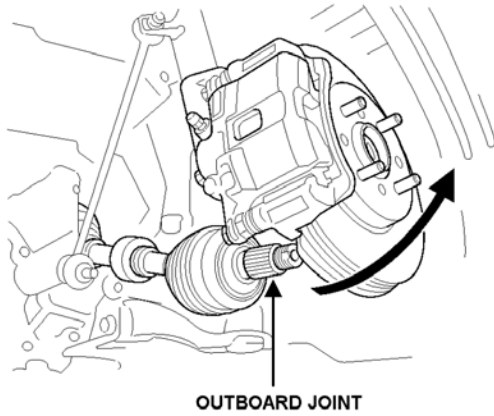

7. *Driver's side driveshaft only:* Use a pry bar to pry the inboard joint from the transmission housing. Then, remove the driveshaft as an assembly.

NOTE:

- Do not pull on the driveshaft, or the inboard joint may come apart.
- Pull the inboard joint straight out to avoid damaging the oil seal.
- Be careful not to damage the transmission oil seal with the pry bar.

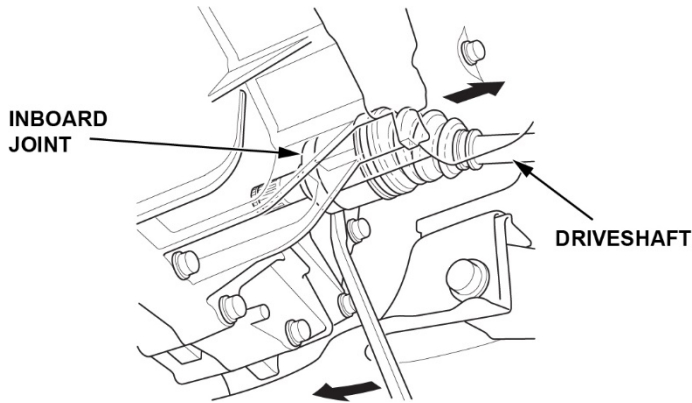

8. *Passenger's side driveshaft only:* Using a punch and hammer, drive the inboard joint off of the intermediate shaft. Then, remove the driveshaft as an assembly.

NOTE:

- Do not pull the assembly by the driveshaft, the inboard joint may come apart.
- Be careful not to damage the transmission oil seal with the pry bar.

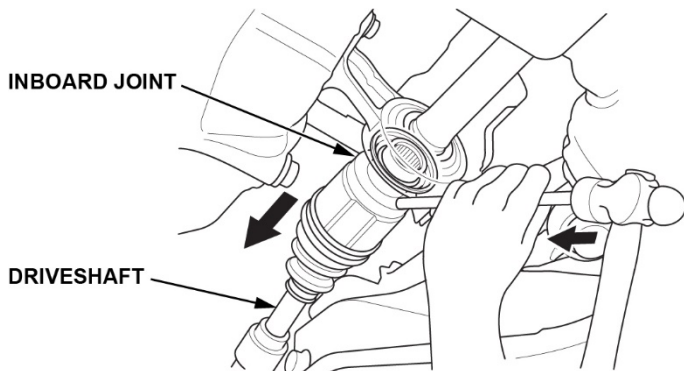

9. *Driver's side driveshaft only:* Replace the set ring on the inboard joint.

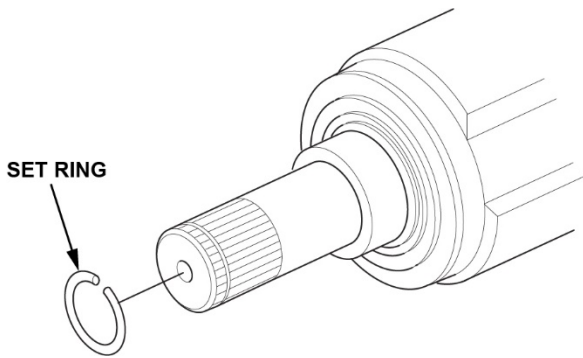

10. *Passenger's side driveshaft only:* Replace the set ring on the intermediate shaft.

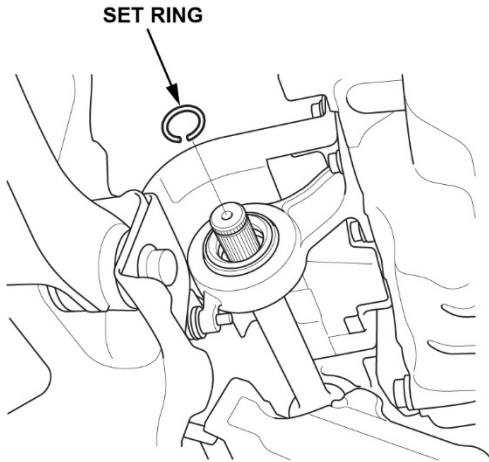

11. Make sure the connecting surfaces of the joint and splined section are clean any debris or rust particles using a shop towel and/or compressed air before starting installation.

12. Apply about **5 g (0.18 oz)** of M-77 Assembly Paste (P/N 08798-9010) to the contact area of the outboard joint and front wheel bearing.

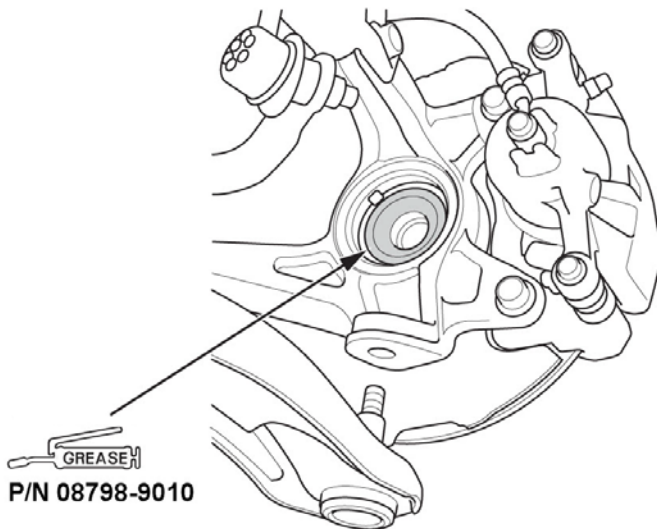

13. Insert the inboard end of the driveshaft into the differential or intermediate shaft until the set ring locks in the groove. Make sure to insert the driveshaft(s) straight in to avoid damaging the oil seal.

NOTE: You do not need to apply any grease to the new driveshaft(s), as they come pre-greased.

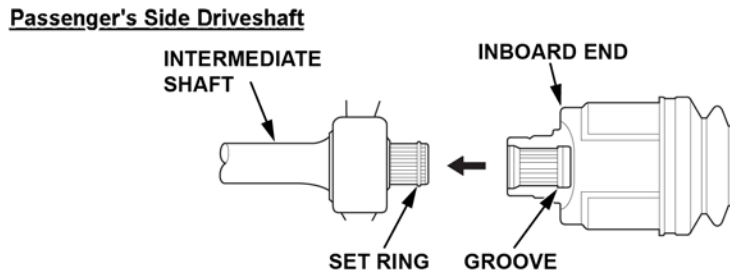
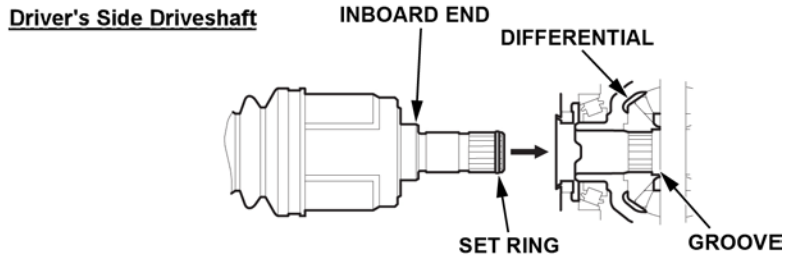

14. Install the outboard joint into the front hub on the knuckle.

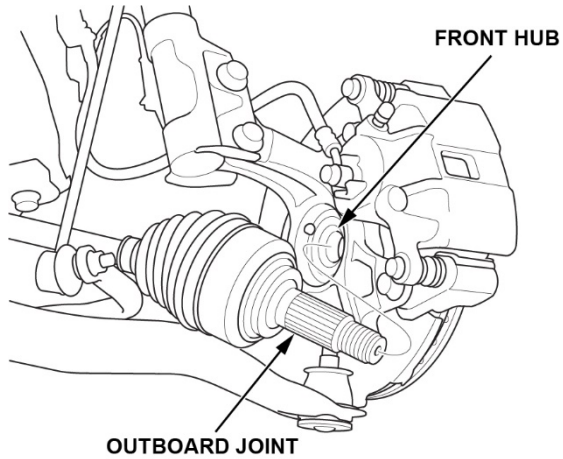

15. Wipe off any grease contamination from the tapered ball joint section and threads, then install the knuckle onto the lower arm. Make sure not to damage the ball joint boot.

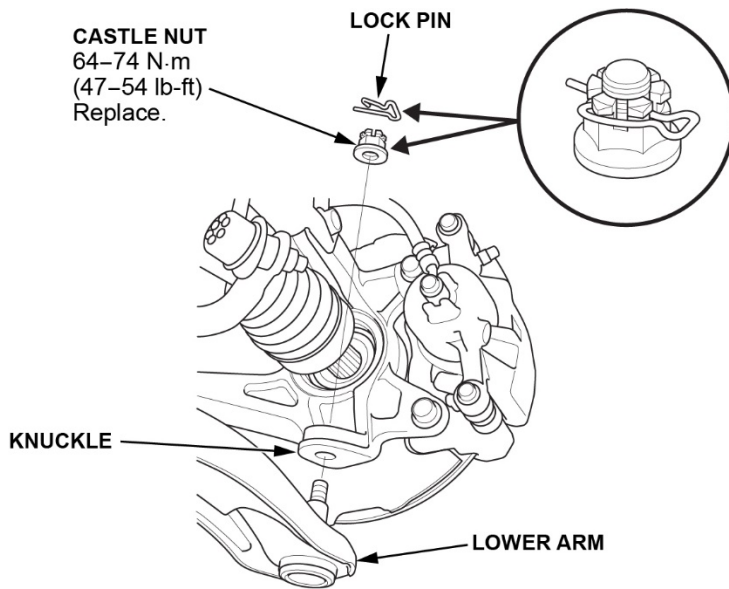

16. Install the new castle nut, and torque it to the lower torque specification. Then, tighten it until the slot on the castle nut aligns with the ball joint pin hole. Install the lock pin into the pin hole as shown.

NOTE: Do not loosen the castle nut to align the castle nut slot and ball joint pin hole.

17. Apply a small amount of engine oil to the seating surface of the new spindle nut. Then, install and torque the spindle nut. After torquing it, use a drift punch to stake the spindle nut shoulder against the driveshaft.

NOTE: If you are going to use an air or battery powered impact gun to install the nut, make sure to turn down the air or power so you do not overtighten it, then torque it to specification using a torque wrench.

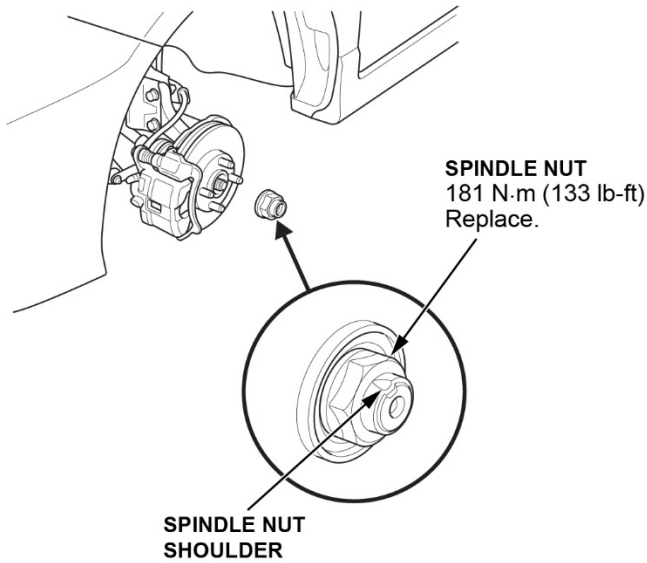

NOTE: It is important to know that many air and battery powered impact guns can achieve 2 or 3 times the axle nuts torque specification. If you severely over-torque an axle nut, it is possible to break a driveshaft as shown below:



18. Clean the mating surfaces of the brake disc and front wheel, then install the front wheels.
19. Turn the front wheel by hand, and make sure there is no interference between the driveshaft and surrounding components.
20. Top off the transmission fluid as needed. Do not fill above the upper mark on the dipstick, and always use ATF-DW1 (P/N 08200-9008).
21. Check the wheel alignment and adjust it if necessary.

END