

N400NAS5



# TECHNICAL BULLETIN

09 DEC 2020

© Jaguar Land Rover North America, LLC

NOTE: The information in Technical Bulletins is intended for use by trained, professional Technicians with the knowledge, tools, and equipment required to do the job properly and safely. It informs these Technicians of conditions that may occur on some vehicles, or provides information that could assist in proper vehicle service. The procedures should not be performed by 'do-it-yourselfers'. If you are not a Retailer, do not assume that a condition described affects your vehicle. Contact an authorized Land Rover service facility to determine whether this bulletin applies to a specific vehicle.

INFORMATION

Changes are highlighted in blue

SECTION:

414-01

SUBJECT/CONCERN:

SAFETY RECALL: Startup Battery Ground Stud - Insufficient Ground Contact

AFFECTED VEHICLE RANGE:

MODEL:	MODEL YEAR:	VIN:
Discovery (LR)	2019-2020	400085-443301

MARKETS:

CANADA, USA

## CONDITION SUMMARY:

### SITUATION:

A potential issue has been identified on certain Land Rover vehicles within the listed Affected Vehicle Range where, due to insufficient contact of the battery ground stud to the chassis, the vehicle may exhibit various electrical faults. The vehicle could cut out while in motion, may lose all electrical power and lighting without warning to the driver. and could lead to an increased risk of an accident.

### ACTION:

Retailers are required to HOLD affected new vehicles that are within your control and refrain from releasing the vehicles for new vehicle sale pending completion of the procedure (s) detailed in this Technical Bulletin. Unsold vehicles should have this performed as part of the Pre-Delivery Inspection (PDI) process but must have it completed prior to vehicle handover to the customer.

Affected vehicles already in the hands of customers should be updated at the next available opportunity.

## PARTS:

DESCRIPTION	PART NUMBER	QUANTITY
M6 Ground stud	LR149837	1

## SPECIAL TOOLS:

The following special tool(s) is required:

- JLR-MRPK4075 **OR**
- JLR-MRPK4081

Refer to the TOPIx Workshop Manual/Workshop Procedure for any additional required special tools.

## WARRANTY:

### NOTE:

Use the Jaguar Land Rover claims submission system to make sure that a vehicle is eligible for this program prior to undertaking any rework action.

At the time of confirming a booking for vehicle repair, make sure that all open Recall and Service Actions are identified to make sure the correct parts are available and adequate workshop time is allocated for repairs to be completed at one visit.

Warranty claims must be submitted quoting the Program Code and the relevant Option Code; this will result in payment of the stated time. The SRO and parts information is included for information only. The Option Code(s) that allows for the drive in/drive out allowance may only be claimed if the vehicle is brought back into the workshop for this action alone to be undertaken.

Repair procedures are under constant review and therefore times/prices are subject to change; those quoted here must be taken as guidance only. Use TOPIx to obtain the latest repair time.

Warranty claims must be submitted or payment within 30 calendar days of completion of the repair.

PROGRAM CODE	OPTION CODE	DESCRIPTION	SRO	TIME (HOURS)	PARTS	QUANTITY
N400	C	Ground stud - Renew	05.10.20	0.2	LR149837	1
N400	D	Ground stud - Renew	05.10.20	0.2	LR149837	1
		Drive in/drive out	02.02.02	0.2	-	-

Normal Warranty policies and procedures apply.

## CUSTOMER REIMBURSEMENT FOR PREVIOUS REPAIRS:

If a customer has indicated that they have already paid for this concern as a normal retail repair (vehicle outside normal warranty period), a copy of the repair invoice must be produced as proof of the repair. The retailer must directly reimburse the customer and a claim for recovery of this cost by using the related damage procedure.

Claims for related damages can only be made when the Recall claim has been paid and accepted. Only vehicles eligible for this Program are included in this process. Only one claim per vehicle for related damages will be accepted. Only repairs performed using approved Jaguar Land Rover parts are eligible for reimbursement.

Submit claims quoting Program Code 'N400' and by clicking the Related Damage radio button on the claim submission screen. Use Option Code 'X' and enter the cost to be reimbursed against the Sundry Code of 'ZZZ999'. All costs are to be entered in local currency. A copy of the invoice must be appended to the repair order for Warranty Audit purposes. Enter a brief comment in the 'Technician Comments' field on the claim to itemize and explain the charges.

SERVICE  
INSTRUCTION:

#### NOTES:

- Some variation in the illustrations may occur, but the essential information is always correct.
- Some components are shown removed for clarity.

1. Open the tailgate.

2. Remove the right loadspace trim panel (see TOPIx Workshop Manual section 501-05: Interior Trim and Ornamentation - Removal and Installation - Right Loadspace Trim Panel).

3. Disconnect the startup battery ground cable (see TOPIx Workshop Manual section 414-00: Battery and Charging System - General Information - Specifications).

4.

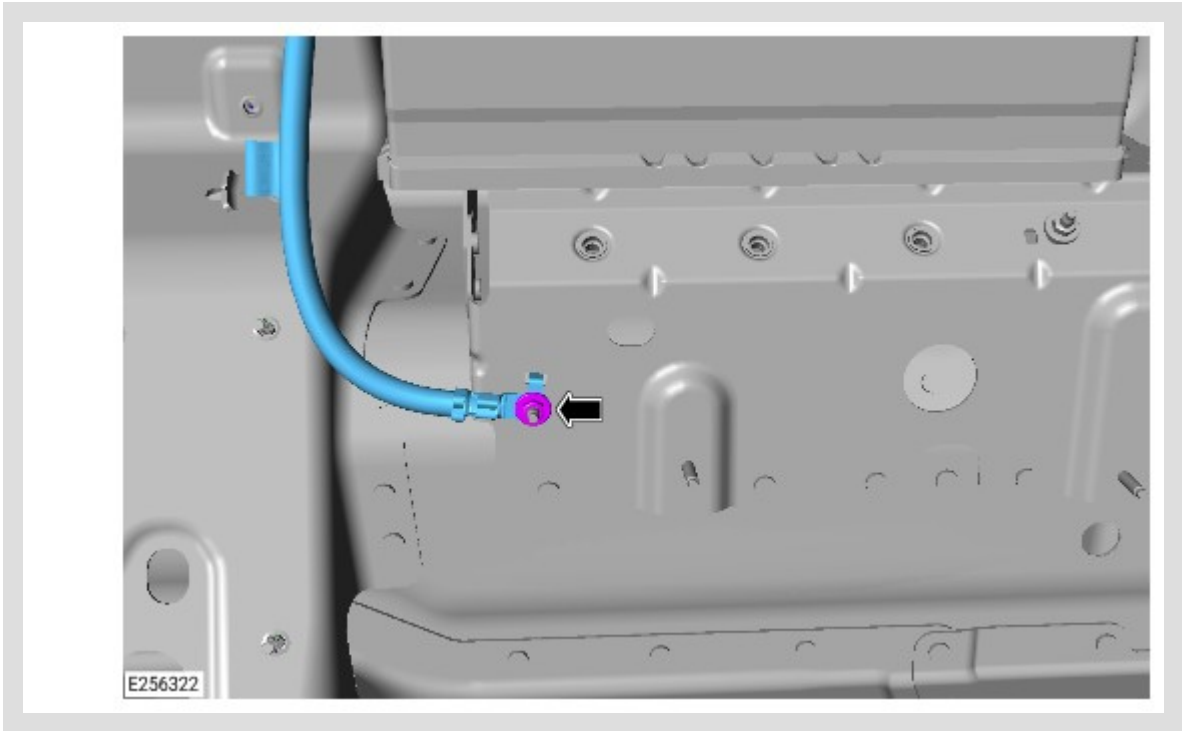

Remove the startup battery ground cable from the body ground stud (G4D178).

5.

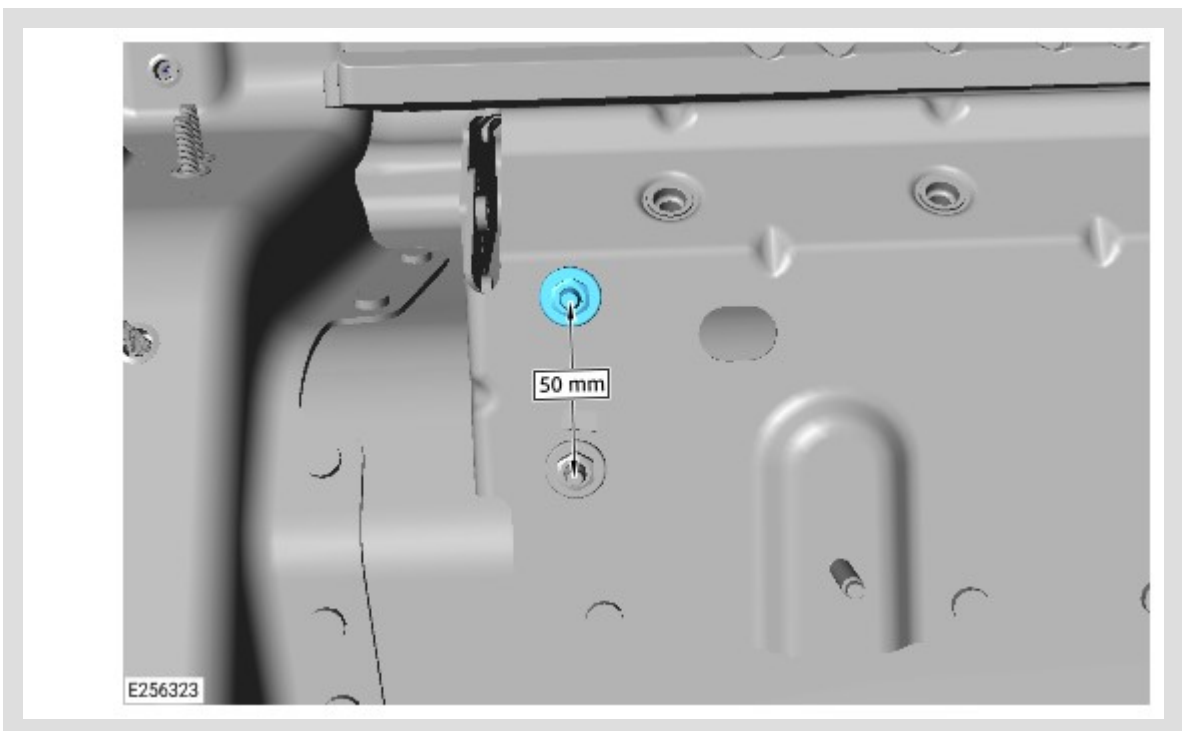

Install a new body ground stud ( [LR149837](#) ) 50 mm above the existing ground stud (see TOPIx Workshop Manual section 501-25A: Body Repairs General Information - General Procedures - Body Earth Stud Repair).

6.

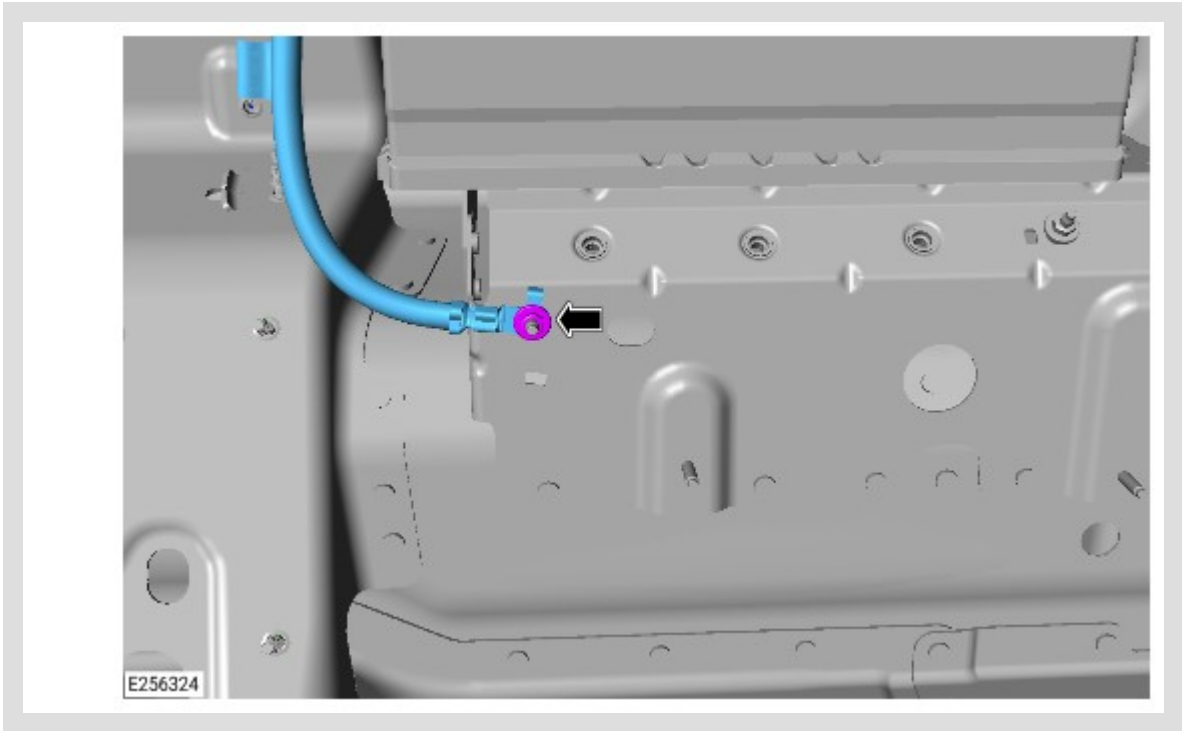

Install the startup battery ground cable to the new body ground stud.

- Torque: **8 Nm**

7.

 **NOTE:**

Make sure the battery terminal is in the correct position.

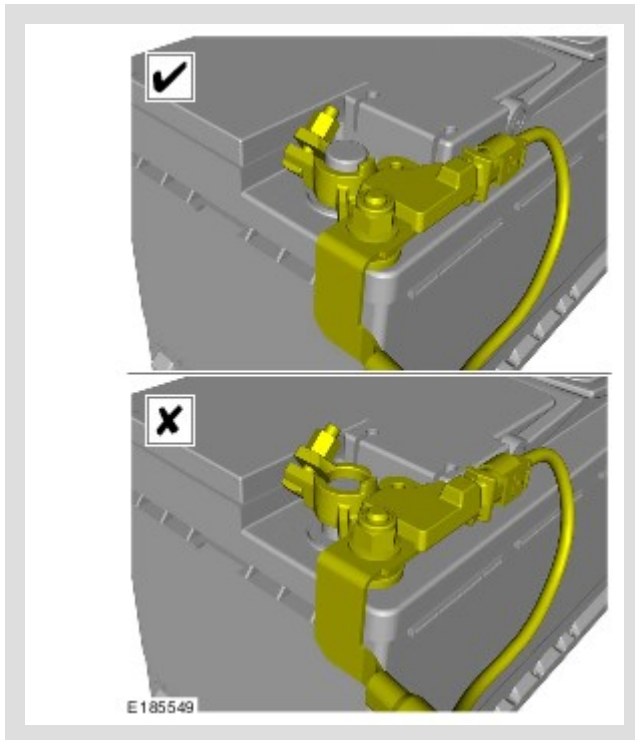

Connect the startup battery ground cable (see TOPIx Workshop Manual section 414-00: Battery and Charging System - General Information - Specifications).

8.

Install the right loadspace trim panel (see TOPIx Workshop Manual section 501-05: Interior Trim and Ornamentation - Removal and Installation - Right Loadspace Trim Panel).

9.

Close the tailgate.