

First Notice



Important Safety Recall

200009



Mandatory Action Required

(NHTSA RECALL NOTICE 20V552)

This recall applies to your trailer mounted boom with the following model(s) and serial numbers:

Table 1. Models and Serial Numbers Affected:

Model	Serial Number	VIN Number	Serial Number	VIN Number
TZ™-50	TZ50J-4154	5D8AA2318L1	TZ50J-4161	5D8AA2316L1
	TZ50J-4155	5D8AA2310L1	TZ50J-4162	5D8AA2318L1
	TZ50J-4156	5D8AA2312L1	TZ50J-4163	5D8AA2318L1
	TZ50J-4157	5D8AA2314L1	TZ50J-4165	5D8AA2313L1
	TZ50J-4158	5D8AA2316L1	TZ50J-4167	5D8AA2317L1
	TZ50J-4159	5D8AA2318L1	TZ50J-4168	5D8AA2318L1
	TZ50J-4160	5D8AA2314L1	TZ50J-4169	5D8AA2310L1

Date: October 7, 2020

This notice is sent to you in accordance with the requirements of the National Traffic and Motor Vehicle Safety Act.

This is to inform you that your vehicle may contain a defect that could affect the safety of a person.

Terex has decided that a defect which relates to motor vehicle safety exists on the model(s) with serial numbers listed above.

The reason for this recall....

You are receiving this bulletin because you are the owner of an affected machine.

Genie has determined that bolted joint connecting the tongue to the chassis in the machines referenced above may not have been torqued to specifications. **Bolted joint not torqued to specifications may come loose and separate from the main chassis. The separation may increase the risk of a crash.**

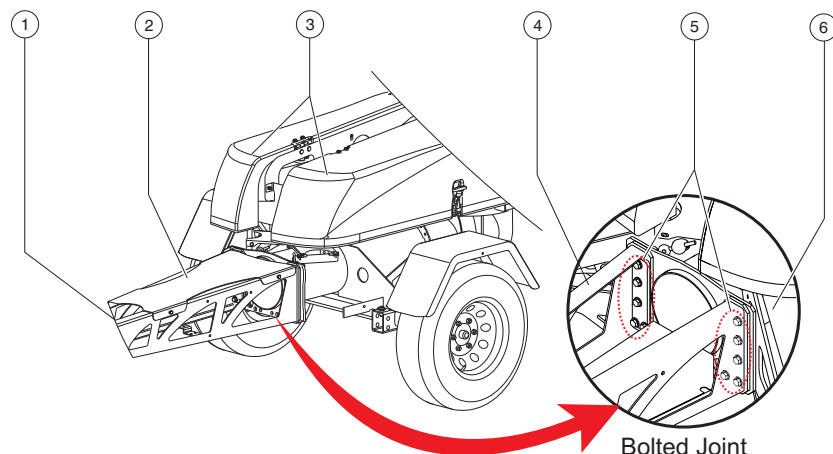

- 1 tongue
- 2 tongue box cover
- 3 turntable covers
- 4 drawbar mount

- 5 retaining fasteners (10X):
 - 6198GT (nut, nylock, 1/2-13)
 - 104235GT (screw, HHC, 1/2-13x2.25 GRD 8)
 - 13066GT (washer, flat,.5 hardened)
- 6 chassis

First Notice



Important Safety Recall

200009

Genie[®]
A TEREX BRAND

Mandatory Action Required

What we are asking you to do...

Tools required:

- 3/4 inch wrench
- 9/16 inch socket
- 3/4 inch socket
- Ratchet
- Torque wrench, 90 ft-lbs / 122 Nm

Note: Perform this procedure on a firm, level surface with the machine in the stowed position and the wheels chocked.

- 1 Locate the affected machines referenced above within your fleet and remove from service.

The machines may only be returned to service after completing this Important Safety Recall.

- 2 Open the turntable covers on both sides of the machine.
- 3 Remove the tongue box cover from the drawbar mount and set aside.
- 4 Torque the retaining fasteners securing the draw bar mount to the chassis.
Torque = 90 ft-lbs / 122 Nm
- 5 Install the tongue box cover.

Completion of this Important Safety Recall must take place as soon as possible, but no later than 14 days from receipt of this notice.

- 6 Fill out and sign the attached completion form and return to Terex AWP Warranty Department or file a warranty claim online to verify that this Important Safety Recall is completed.
- 7 Return the machine to service.

Warranty:

The labor and travel miles required to perform this Bulletin are covered under the provisions of our LIMITED PRODUCT WARRANTY statement. If you are the owner of an affected machine and are not an authorized Terex AWP dealer, please contact your nearest AWP dealer for assistance in completing this Bulletin. Only Terex AWP authorized dealers will be reimbursed for labor or any other costs associated with this Bulletin under the provisions of our standard warranty terms and conditions. Warranty claims are submitted online by dealers. To file a claim, logon to:

<https://www.gogenielift.com>

If you need more information about filing a warranty claim, please contact Terex AWP Warranty Department at:

Warranty Claims:

The labor hours allowed for this campaign is 30 minutes.

First Notice



Important Safety Recall

Mandatory Action Required

200009

Genie[®]
A TEREX BRAND

If you are the lessor of any of the affected vehicles ...

If you are the lessor of this vehicle, federal law requires you to forward this notice to the lessee within ten days of your receipt of this letter.

If you need help.....

If you have questions or concerns regarding this recall, please contact Genie Product Support at 1 800-536-1800 or the service manager at your local dealer. If Genie or your dealer fail or are unable to remedy the defect without charge or within a reasonable time, you may also submit a written complaint to the Administrator, National Highway Traffic Safety Administration, 1200 New Jersey Avenue, SE., Washington, DC 20590, or call the toll-free Vehicle Safety Hotline at 1-888-327-4236 (TTY: 1-800-424-9153); or go to <http://www.safercar.gov>.

We are intensely concerned for the safety of our customers and sincerely appreciate your efforts. Thank you for your attention to this important matter.

Enclosures:

- Customer Machine List
- New Owner Update Form
- Completion Form



Important Safety Recall 200009

New Owner Update Form

(for updating machine owner information only)

Genie local standards requires that the seller of a Genie machine report to Genie the model and serial number of each machine sold, as well as the name, address, and telephone number of the new owner, within 60 days of the sale.

- If you have sold a machine, list new owner's name, address and phone number, for each machine. List complete model and serial number (ex. TZ50J-4158)

New Owner Information:

	Machine 1	Machine 2	Machine 3
Model*	<input type="text"/>	<input type="text"/>	<input type="text"/>
Serial Number *	<input type="text"/>	<input type="text"/>	<input type="text"/>
Owner Name*	<input type="text"/>	<input type="text"/>	<input type="text"/>
Address 1*	<input type="text"/>	<input type="text"/>	<input type="text"/>
Address 2	<input type="text"/>	<input type="text"/>	<input type="text"/>
City/State/Zip*	<input type="text"/>	<input type="text"/>	<input type="text"/>
Phone Number*	<input type="text"/>	<input type="text"/>	<input type="text"/>
Contact Person	<input type="text"/>	<input type="text"/>	<input type="text"/>

* Required fields

Seller Information:

Date:

Company Name:

Account #:

Address:

(street):

(city):

(state, zip code) :

Phone #:

- List any machines that could not be inspected or repaired because of the following:

Model & Serial Number	Scrapped	Exported	Stolen	Other (explain)
<input type="text"/>	<input type="checkbox"/>	<input type="checkbox"/>	<input type="checkbox"/>	<input type="text"/>
<input type="text"/>	<input type="checkbox"/>	<input type="checkbox"/>	<input type="checkbox"/>	<input type="text"/>
<input type="text"/>	<input type="checkbox"/>	<input type="checkbox"/>	<input type="checkbox"/>	<input type="text"/>

Email to: AWP.Warranty@terex.com



Important Safety Recall 200009

Completion Form

Your signature on this form will verify that the machines below have been inspected and verified to not require the modification per Safety Notice 200009.

Please note that this is not a Warranty Claim Form. A Warranty Claim Form must be submitted to the Terex AWP Warranty Department for reimbursement under the provisions of our standard warranty terms and conditions.

Email to: AWP.Warranty@terex.com

Date: _____

Company Name: _____

Account # (if applicable): _____

Address: _____

(street): _____

(city): _____

(state, zip code): _____

Phone: _____

Please list the complete machine serial number (ex. TZ50J-4158)

Model Number	Serial Number	Model Number	Serial Number
_____	_____	_____	_____
_____	_____	_____	_____
_____	_____	_____	_____
_____	_____	_____	_____
_____	_____	_____	_____
_____	_____	_____	_____
_____	_____	_____	_____
_____	_____	_____	_____

Print (service manager)

Signature

Date