



Compliance Recall

Code: 69AY

Subject Passenger Airbag

Release Date October 13, 2020

Affected Vehicles

Country	Beginning Model Year	Ending Model Year	Vehicle	Vehicle Count
USA	2020	2020	PASSAT	1,829
CAN	2020	2020	PASSAT	290

Check Campaigns/Actions screen in ELSA on the day of repair to verify that a VIN qualifies for repair under this action. ELSA is the only valid campaign inquiry & verification source.

- ✓ Campaign status must show "open."
- ✓ If ELSA shows other open action(s), inform your customer so that the work can also be completed at the same time the vehicle is in the workshop for this campaign.

Problem Description The passenger frontal airbag may not have been folded properly during airbag production. Because of this, there is a potential that, in a crash with airbag deployment, the passenger airbag may deploy too forcefully, increasing the risk of injury.

Corrective Action Replace passenger frontal airbag.

Code Visibility On or about October 13, 2020, the campaign code will be applied to affected vehicles.

Owner Notification Owner notification will take place in October 2020. Owner letter examples are included in this bulletin for your reference.

Additional Information Please alert everyone in your dealership about this action, including Sales, Service, Parts and Accounting personnel. Contact Warranty if you have any questions.

IMPORTANT REMINDER ON VEHICLES AFFECTED BY SAFETY & COMPLIANCE RECALLS

New Vehicles in Dealer Inventory: It is a violation of federal law for a dealer to deliver a new motor vehicle or any new or used item of motor vehicle equipment (including a tire) covered by this notification under a sale or lease until the defect or noncompliance is remedied. By law, dealers must correct, prior to delivery for sale or lease, any vehicle that fails to comply with an applicable Federal Motor Vehicle Safety Standard or that contains a defect relating to motor vehicle safety.

Pre-Owned Vehicles in Dealer Inventory: Dealers should not deliver any pre-owned vehicles in their inventory which are involved in a safety or compliance recall until the defect has been remedied.

Dealers must ensure that every affected inventory vehicle has this campaign completed before delivery to consumers.

Fill out and affix Campaign Completion Label (CAMP 010 000) after work is complete. Labels can be ordered at no cost via the Compliance Label Ordering portal at www.vwhub.com.

Parts Information

Parts Control Type: VIN to Order	If parts are needed to support a vehicle repair: <ul style="list-style-type: none"> • US Dealers - use AVA • CAN Dealers - contact the Parts Specialists via phone (800-767-6552), email (VWoAPartsSpecialists@vw.com), or chat/text with the VIN to order
---	--

Initial Allocation: YES	Dealers will be sent an initial allocation prior to customer notification. If no initial allocation was received, please reference the Repair Projection Tool (below) to view your potential VIN population.
--	--

Repair Projection Tool: (right click to open)	
--	---

Criteria	Quantity	Part Number	P.O.C. Part Description	Ordering Method
01	1	561-880-204-D	Airbag	VIN to Order

NOTE

The specified part numbers reflect the status at the start of this service action. Interim updates made in ETKA can cause a listed part number to become unavailable. In this case, the new part number specified in ETKA should be used.

Claim Entry Instructions

The labor times listed here may differ from the labor operations and labor times listed in ELSA.

After campaign has been completed, enter claim as soon as possible to help prevent work from being duplicated elsewhere. Attach the ELSA screen print showing action open on the day of repair to the repair order.

If customer refused campaign work:

- ✓ U.S. dealers: Submit request via WISE under the *Campaigns/Update/Recall Closure* option.
- ✓ Canada dealers: Upload the repair order [signed by customer] to Volkswagen WIN/Operations/Campaign Closure.

Service Number	69AY		
Damage Code	0099		
Parts Vendor Code	WWO		
Claim Type	Sold vehicle: 7 10 Unsold vehicle: 7 90		
Causal Indicator	Mark Airbag* as causal part		
Vehicle Wash/Loaner	Do not claim wash/loaner under this action U.S.A.: Loaner/rental coverage cannot be claimed under this action. However, loaner/rental may be covered under the Alternate Transportation Program. Please refer to the Volkswagen Warranty Policy and Procedures Manual for loaner claims information and reimbursement details. Canada: Loaner/rental coverage cannot be claimed under this action. Please refer to Volkswagen Service Loaner Program to determine loaner eligibility.		
Criteria I.D.	01		
	LABOR		
	Labor Op	Time Units	Description
	6959 55 99	100	Replace passenger airbag and clear repair related faults
	PARTS		
	Quantity	Part Number	Description
	1.00	561880204D	Airbag*

Customer Letter Example (USA)

<MONTH YEAR>

<CUSTOMER NAME>

<CUSTOMER ADDRESS>

<CUSTOMER CITY STATE ZIPCODE>

This notice applies to your vehicle: <MODEL YEAR> <BRAND> <CARLINE>, <VIN>

NHTSA: 20V533

Subject: Compliance Recall 69AY – Passenger Airbag

Dear Volkswagen Owner,

This notice is sent to you in accordance with the National Traffic and Motor Vehicle Safety Act. Volkswagen has decided that certain 2020 model year Volkswagen Passat vehicles fail to conform to Federal Motor Vehicle Safety Standard (FMVSS) No. 208 - *Occupant Crash Protection*. Our records show that you are the owner of a vehicle affected by this action.

What is the issue?

The passenger frontal airbag may not have been folded properly during airbag production. Because of this, there is a potential that, in a crash with airbag deployment, the passenger airbag may deploy too forcefully, increasing the risk of injury.

What will we do?

To correct this noncompliance, your authorized Volkswagen dealer will replace the passenger frontal airbag. This work will take about two hours to complete and will be performed for you free of charge. Please keep in mind that your dealer may need additional time for the preparation of the repair, as well as to accommodate their daily workshop schedule.

What should you do?

Please contact your authorized Volkswagen dealer without delay to schedule this recall repair. To set up an appointment online, please visit www.vw.com/find-a-dealer.

Lease vehicles and address changes

If you are the lessor and registered owner of the vehicle identified in this action, the law requires you to forward this letter immediately via first-class mail to the lessee within ten (10) days of receipt. If you have changed your address or sold the vehicle, please fill out the enclosed prepaid Owner Reply card and mail it to us so we can update our records.

Can we assist you further?

If your authorized Volkswagen dealer fails or is unable to complete this work free of charge within a reasonable time, or if you should have any questions about this communication, please reach out to us using your preferred method of communication at www.vw.com/contact or by calling us at 800-893-5298.

Checking your vehicle for open Recalls and Service Campaigns

To check your vehicle's eligibility for repair under this or any other recall/service campaign, please visit www.vw.com/owners/recalls and enter your Vehicle Identification Number (VIN) into the Recall/Service Campaign Lookup tool.

If you still cannot obtain satisfaction, you may file a complaint with: The Administrator, National Highway Traffic Safety Administration, 1200 New Jersey Avenue, SE., Washington, DC 20590; or call the toll-free Vehicle Safety Hotline at 1-888-327-4236 (TTY: 1-800-424-9153); or go to <http://www.safercar.gov>.

We apologize for any inconvenience this matter may cause; however we are taking this action to help ensure your safety and continued satisfaction with your vehicle.

Sincerely,

Volkswagen Customer Protection

Customer Letter Example (CANADA)

<MONTH YEAR>

<CUSTOMER NAME>

<CUSTOMER ADDRESS>

<CUSTOMER CITY STATE ZIPCODE>

This notice applies to your vehicle: <MODEL YEAR> <BRAND> <CARLINE>, <VIN>

Transport Canada Recall: 2020-412

Subject: Compliance Recall 69AY – Passenger Airbag

Dear Volkswagen Owner,

This notice is sent to you in accordance with the requirements of the *Motor Vehicle Safety Act*. This is to inform you that your vehicle may be non-compliant with the requirements of the *Motor Vehicle Safety Regulations* and that the non-compliance could affect the safety of a person. Our records show that you are the owner of a vehicle affected by this action.

What is the issue? The passenger frontal airbag may not have been folded properly during airbag production. Because of this, there is a potential that, in a crash with airbag deployment, the passenger airbag may deploy too forcefully, increasing the risk of injury.

What will we do? To correct this noncompliance, your authorized Volkswagen dealer will replace the passenger airbag. This work will take about two hours to complete and will be performed for you free of charge. Please keep in mind that your dealer may need additional time for the preparation of the repair, as well as to accommodate their daily workshop schedule.

What should you do? Please contact your authorized Volkswagen dealer without delay to schedule this recall repair.

Lease vehicles and address changes If you are the lessor and registered owner of the vehicle identified in this letter, you shall forward this letter (and any subsequent notice, if applicable) to the lessee within ten (10) days of receipt. If you have changed your address or sold the vehicle identified in this letter, please fill out the enclosed prepaid Owner Reply Card and mail it to us so we can update our records.

Can we assist you further? If your authorized Volkswagen dealer fails or is unable to complete this work free of charge within a reasonable time, please contact Customer Relations, Monday through Friday from 8AM to 8PM EST by phone at 1-800-822-8987 or via our "Contact Us" page at www.vw.ca.

We apologize for any inconvenience this matter may cause; however we are taking this action to help ensure your safety and continued satisfaction with your vehicle.

Sincerely,

Volkswagen Customer Protection

Repair Overview

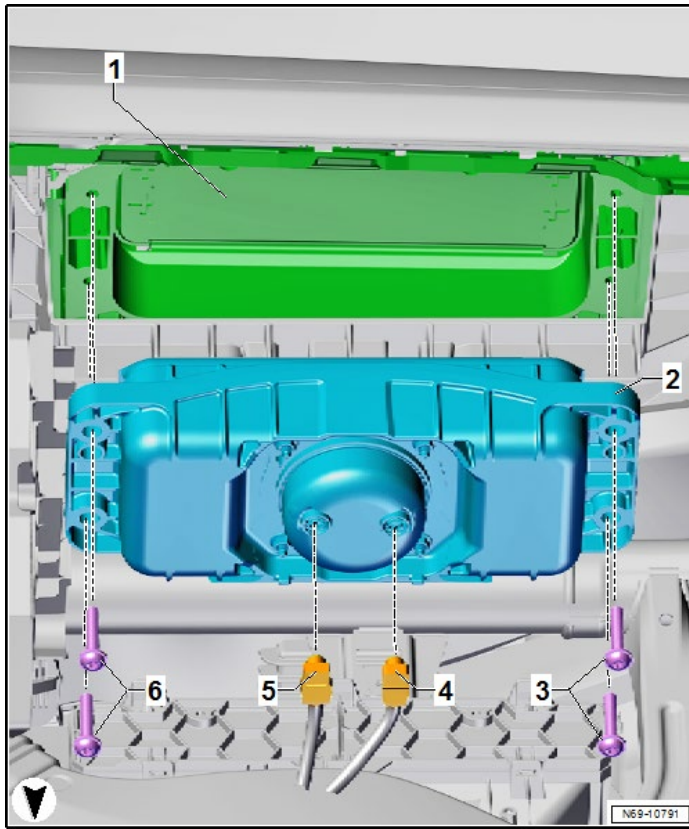

- Replace passenger frontal airbag.

NOTE

- These repair instructions may differ from the labor operations and labor times listed in ELSA.
- Damages resulting from improper repair or failure to follow these work instructions are the dealer's responsibility and are not eligible for reimbursement under this action.
- This procedure must be read in its entirety prior to performing the repair.
- Due to variations in vehicle equipment and options, the steps/illustrations in this work procedure may not identically match all affected vehicles.
- Diagnosis and repair of pre-existing conditions in the vehicle are not covered under this action.
- When working during extreme temperatures, it is recommended that the vehicle be allowed to acclimate inside the shop to avoid temperature-related component damage/breakage.

Required Tools



Trim Removal Wedge

-3409-

(or equivalent)

Repair Instruction

Section A - Check for Previous Repair

TIP

If Campaign Completion label is present, no further work is required.

Applicable criteria ID(s)	Campaign/Action Status
01 ← 2	Open ← 1

EXAMPLE

Campaign/Action	Start	Designation
	2015-11-10	W-SERV_ACT -
	2018-12-13	RECALL -
	2017-05-16	A-RECALL -

EXAMPLE

- Enter the VIN in Elsa and proceed to the “Campaign/Action” screen.

TIP

On the date of repair, print this screen and keep a copy with the repair order.

- Confirm the Campaign/Action is open <arrow 1>. If the status is closed, no further work is required.
- Note the Applicable Criteria ID <arrow 2> for use in determining the correct work to be done and corresponding parts associated.

CRITICAL REPAIR STEP



If multiple software update Campaign/Actions are open, they must be performed in order of the Start date <arrow 3>. The oldest should be performed first.

- **All Safety Recalls must be completed prior to completing this campaign.**
- **Proceed to Section B.**

Section B – Repair Procedure

WARNING

Risk of injury. Refer to “Warning and Safety Precautions”, found in **Appendix A** at the end of this document.

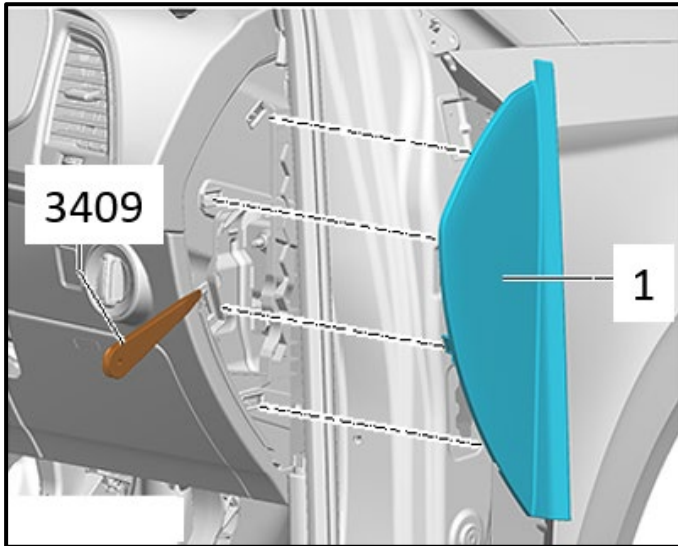

Remove instrument panel side cover:

- Carefully fold the door seal molding outward in the instrument panel cover area.
- Pry out the instrument panel side cover <1> with the -3409- near the catches.
- Pull the cover toward the rear and remove it.

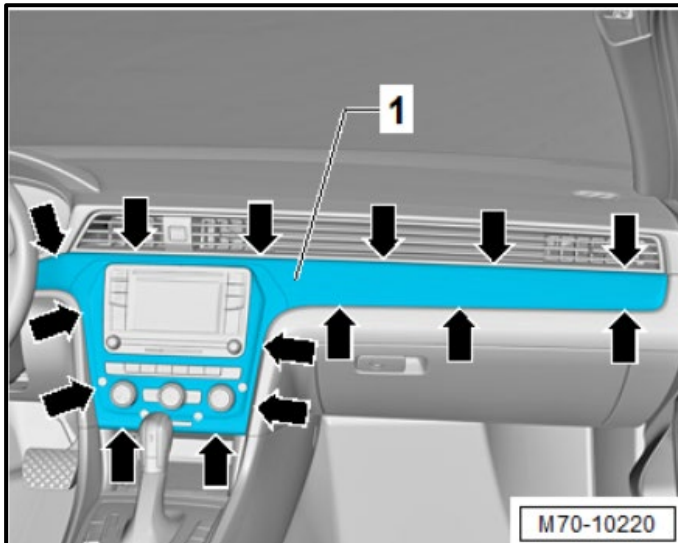

Remove passenger side instrument panel decorative trim:

- Using the full steering column adjustment range move the steering wheel as far to the rear and down as possible.
- Working from the outside inward, carefully detach the decorative trim <1> from the retainers <arrows> using the -3409-.

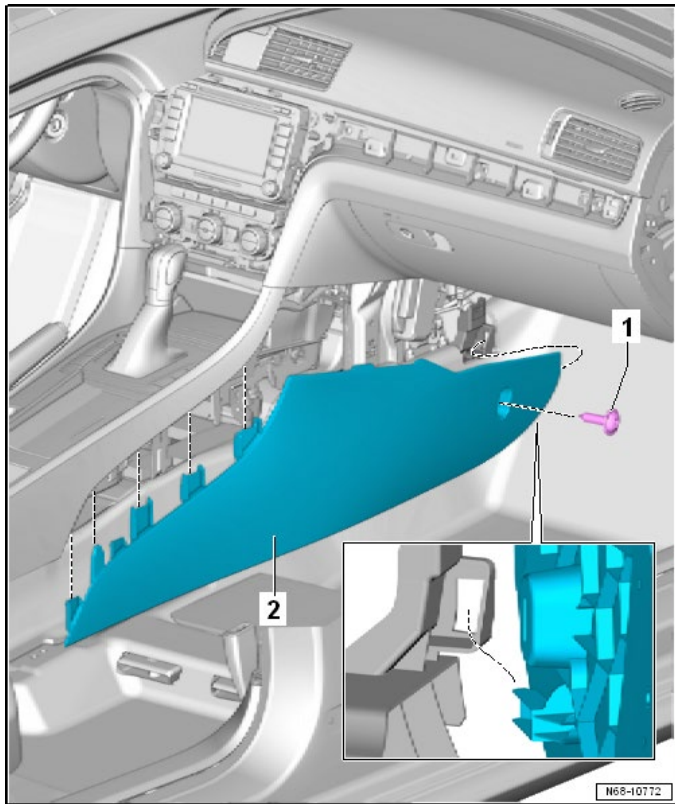

Remove passenger side center console trim:

- Remove screw <1>.
- Pull down the center console side trim <2> slightly, guide out of the front mount and remove from the center console.

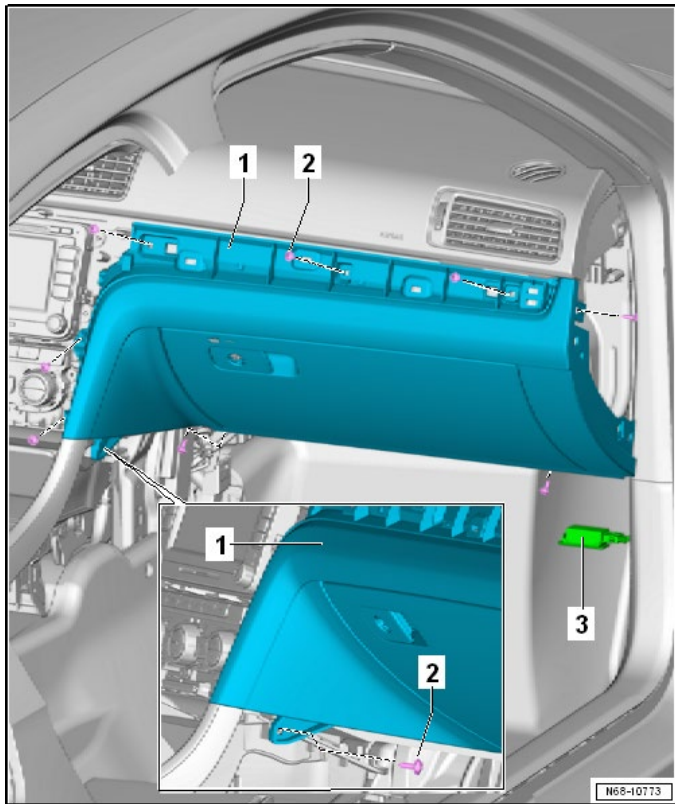

Remove lamps and glove compartment screws:

- Carefully pry out and disconnect glove compartment light (if equipped).
- Carefully pry out and disconnect right footwell lamp <3>.
- Remove the screws <2> from the glove compartment <1>.

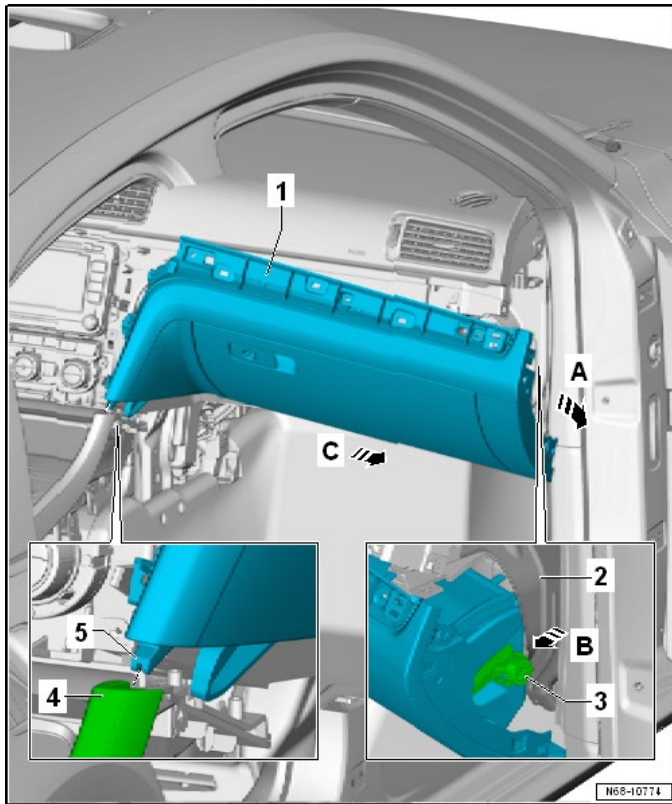

Remove glove compartment:

- Loosen glove compartment <1> from the instrument panel and lower to the side in the direction of <arrow A>.
- Remove the glove compartment guide <5> from the center console <4>.

NOTE

It is easier to guide the damping element <3> past the instrument panel crossmember <2> when the glove compartment lid is slightly open.

- Carefully guide the glove compartment damping element <3> past the instrument panel crossmember <2> in the direction of <arrow B>.
- At the same time, release and disconnect any wiring harnesses and connectors (depends on vehicle equipment).
- Lower the glove compartment <1> and remove from the vehicle in the direction of <arrow C>.

WARNING

Accident risk. When working on pyrotechnic components (such as airbags and belt tensioners), the battery must be disconnected with the ignition switched **ON**.

- Turn **ON** the ignition.
- Move the passenger seat to the most rearward position.
- Fully recline passenger seat.

CAUTION

Reclining the passenger seat before disconnecting the battery allows for additional safety in the event Terminal 15 power is not restored when reconnecting the battery at the end of the repair.

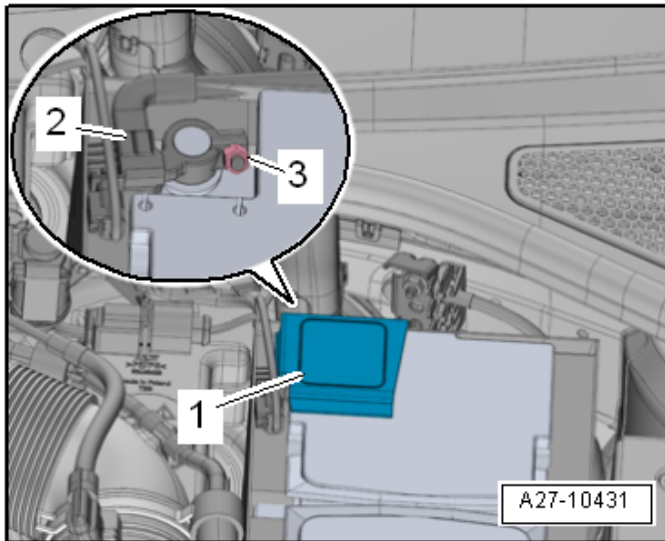

- Open the cover <1> over the battery ground terminal post.
- Loosen the nut <3>.
- Remove and isolate the battery ground cable <2> from the battery terminal.

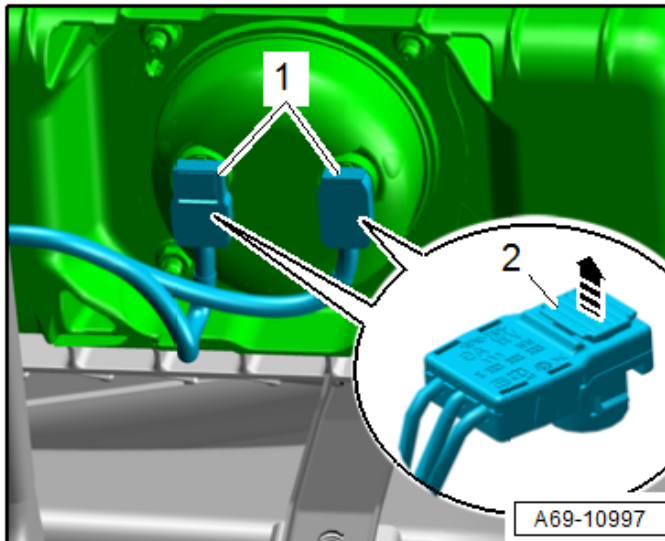

Disconnect airbag connectors:

⚠ WARNING

Before handling pyrotechnic components (for example, disconnecting the connector), the person handling it must “discharge static electricity”. This can be done by touching the door striker, for example.

- Release the connector locks <2> with a small screwdriver <arrow>.
- Release and disconnect the connectors <1> from the Front Passenger Airbag Igniter 1 -N131- and Front Passenger Airbag Igniter 2 -N132-.

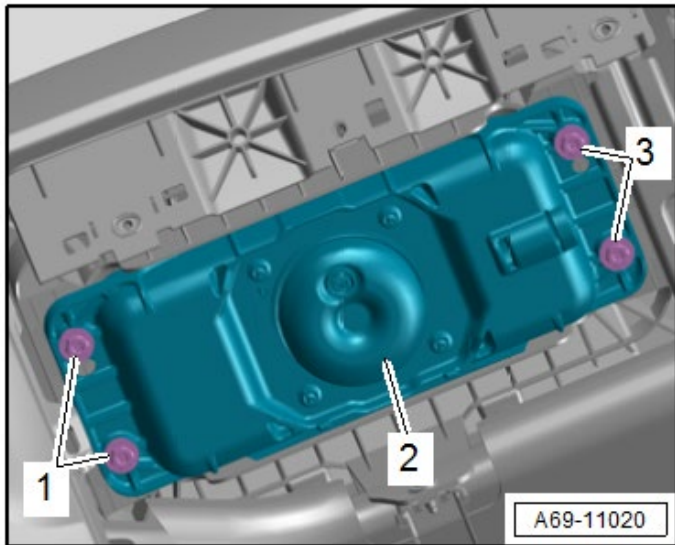

- Support the Front Passenger Airbag Unit <2> to prevent it from falling out.

TIP

Leaving one of the bolts <1 or 3> installed a few turns will help support the airbag while removing the remaining bolts.

- Remove the bolts <1 and 3>.
- Remove the Front Passenger Airbag Unit <2> downward.

WARNING

Lay the airbag so that the collision cushion faces upward.

- Clean the bolts and the threads in the instrument panel for bolts <1 and 3> with a 6 x 1.0 mm thread cleaner or tap.
- Apply high strength thread locking fluid (Loctite® 648™) on the bolts <1 and 3>.
- Install new Front Passenger Airbag Unit and torque bolts <1 and 3> to 8 Nm.

Part Number	Part Description
561-880-204-D	Passenger Airbag

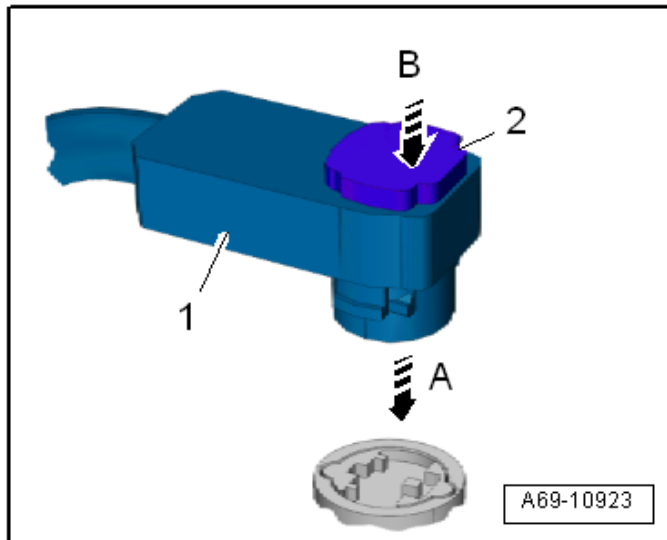

Connect airbag igniter connectors:

- Connect the connector <1> to the airbag igniter in direction of <arrow A>.
- Press in the connector lock <2> in direction of <arrow B>. While doing this, the connector is pushed into the airbag igniter and locks into place.

Reinstall glove compartment and interior trim:

- Installation is the reverse order of removal.
- Ensure all electrical connectors are connected.
- Torque screws to 1.5 Nm.

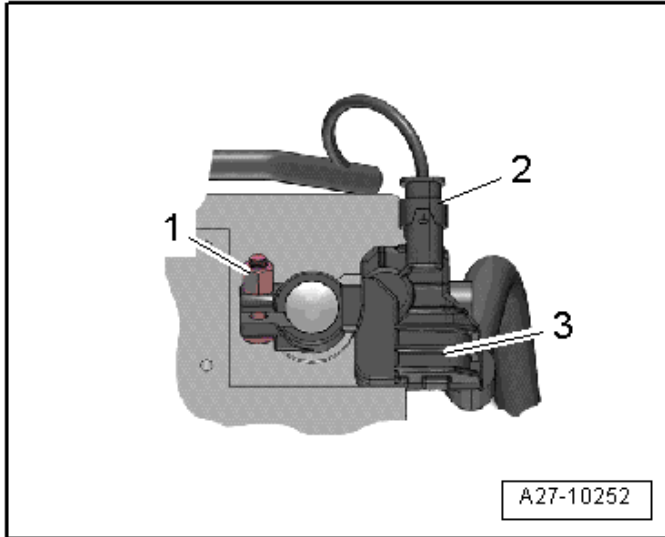

Reconnect battery:

⚠ WARNING

Ignition must be **ON** when connecting battery. If pyrotechnic components (e.g. airbag, belt tensioner) are not repaired correctly, they may deploy unintentionally after connecting battery. There must not be anyone inside the vehicle when connecting the battery.

- Disconnect the connector <2> from the Battery Monitoring Control Module -J367- <3> (if equipped).
- Attach the battery ground cable clamp by hand to the battery negative terminal and torque the nut <1> to 6 Nm.
- Reconnect the connector to the Battery Monitoring Control Module -J367- (if equipped).
- Cycle the ignition off and back on.
- Bring passenger seat to an upright position.
- Set clock to local time.
- Activate the convenience open/close functions.
- Check the DTC memories of all the control units and erase under-voltage faults if necessary.

! NOTE

- After connecting the battery and switching on the ignition, the ASR/ESP Control Lamp -K155- and Electromechanical Power Steering Indicator Lamp light up continuously. The indicator lamps switch off automatically after driving a short distance (less than 100 meters). This activates Steering Angle Sensor -G85-.
- Once -G85- is activated and the ignition is cycled, the Start/Stop function will also start working again and any faults related to the battery being disconnected should be able to be cleared.

Proceed to Section C.

Section C – Campaign Completion Label

Install Campaign Completion Label

- Fill out and affix Campaign Completion Label, part number CAMP 010 000, next to the vehicle emission control information label.



TIP

Ensure Campaign Completion Label does not cover any existing label(s).

Proceed to Section D

Section D - Parts Return/Disposal

Properly store (retain), destroy or dispose of removed parts in accordance with all state/province and local requirements, unless otherwise indicated and/or requested through the Warranty Parts Portal (WPP) for U.S. and the Part Destruction and Core Disposition Report for Canada.

Appendix A – Warning and Safety Precautions

WARNING

General Safety Precautions when Working with Pyrotechnic Components:

- Pyrotechnic components always contain propellant that generates a gas during combustion. In some components, there is also a supply of pressurized gas to ensure this gas is generated
- This pressurized gas is stored under high pressure in a compressed gas container. Pyrotechnic components are triggered by electrical/mechanical igniters.
- Only trained personnel should perform testing, assembly and servicing work. Airbags do not have a replacement interval.
- Never check with test lamps, voltmeter or ohmmeters.
- Only check pyrotechnic components when they are installed in the vehicle using vehicle diagnosis, testing and information systems approved by the manufacturer.
- When working on pyrotechnic components and the airbag control module, disconnect the battery ground strap while the ignition is switched on. Then cover the negative terminal.
- Wait 10 seconds after disconnecting the battery.
- The ignition must be SWITCHED ON when connecting the battery. There should not be anyone inside the vehicle when doing this.
- Exception: vehicles with batteries in the passenger compartment. In this case, stay outside the range of the airbags and seat belts.
- Wash your hands after touching ignited pyrotechnic components from the restraint system.
- Do not open or repair pyrotechnic components. Use only new components to reduce the risk of injury.
- Do not install pyrotechnic components that have fallen onto a hard surface or show signs of damage.
- Discharge static electricity before handling pyrotechnic components, for example before disconnecting the electrical connector. This can be done by touching grounded metal objects such as the door striker pin.
- Install pyrotechnic components immediately after removing them from their transport packaging. If you must stop working, store the pyrotechnic component in its original transport packaging.
- Do not leave pyrotechnic components lying in the open unattended.
- Do not treat pyrotechnic components with grease, cleaning solutions or similar products.
- Do not expose pyrotechnic components to temperatures above 100 °C, even for brief periods of time.
- People in the immediate vicinity of the workplace must be protected from possible noise and projectiles.
- Pyrotechnic components can trigger unintentionally.
- In the event of unintentional deployment:
 - Single-stage inflators: allow airbag to cool down completely. Wait at least 10 minutes before handling.
 - Two-stage inflators: wait for second airbag ignition. Allow airbag to cool down completely. Wait at least 10 minutes before handling.