

ALA8 - Re-Screwing All-Wheel Final Drive and Replacing All-Wheel Final Drive if Necessary (Stop Delivery/Recall Campaign)

Vehicle Type: **911 Carrera 4S (992)**
911 Carrera 4S Cabriolet (992)

Model Year: **2020**

Subject: **All-wheel final drive on the front axle**

Information: **There is a possibility that the all-wheel final drive was not screwed to the transmission support according to specifications on the affected vehicles due to a process error by the supplier.**

If this is the case, the threaded joint between the final drive and transmission support can sometimes loosen after the vehicle has been in service for just a short time. The customer may notice significant rumbling or knocking noises and vibrations from around the body front section.

If the customer continues to drive the vehicle, the final drive can move out of its installation position, causing damage to adjacent components such as the fuel tank or drive shafts. If the fuel tank is damaged in this way, fuel can also leaked out. A potential risk of fire cannot be completely ruled out if leaking fuel comes into contact with a source of ignition.

Remedial Action: Remove all-wheel final drive, re-screw bracket for final drive and install final drive again.



Information

If one or both **fastening screws** on the final drive bracket have already **loosened**, the **final drive must be replaced**.

The vehicle must also be checked for signs of damage and the relevant components must be replaced.

Affected Vehicles: Only vehicles assigned to the campaign (see also PCSS Vehicle Information). This campaign affects 14 vehicles in North America.

Installation
position:

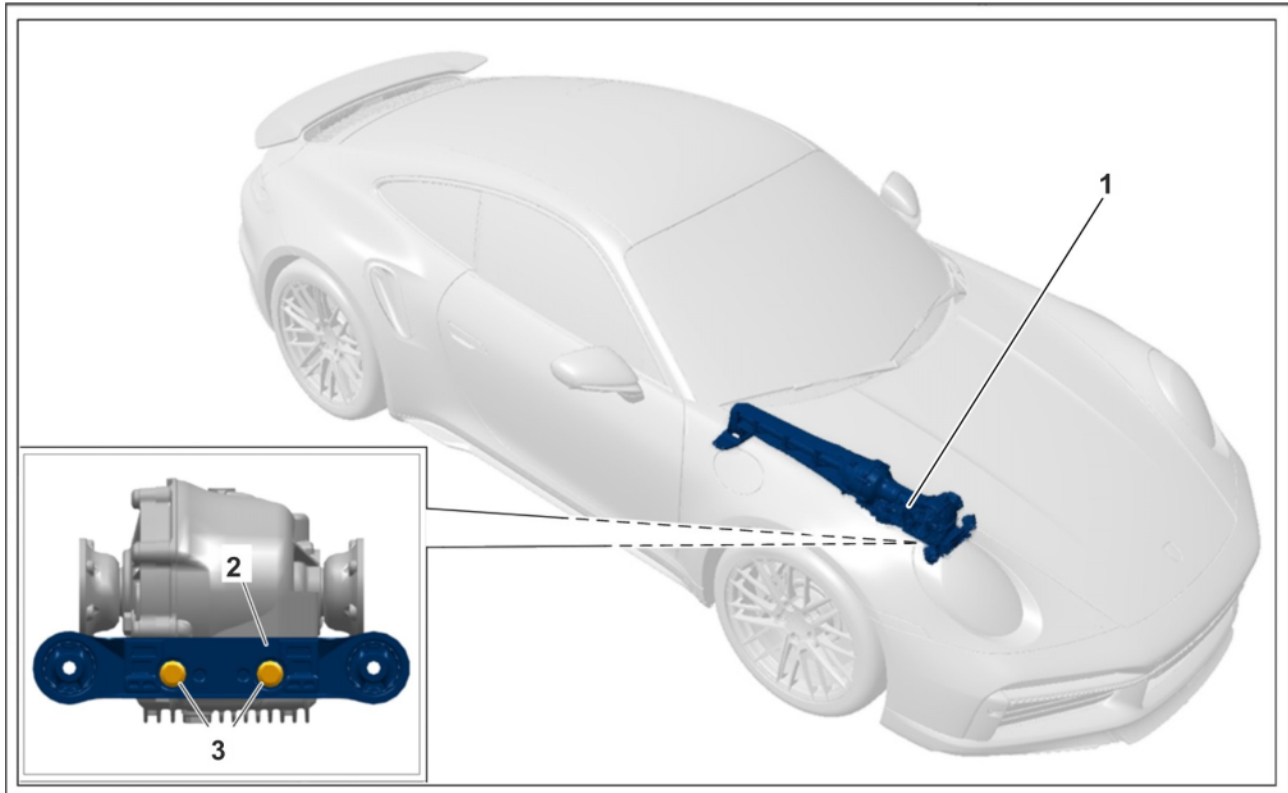

Installation position overview

- 1 – All-wheel final drive (**replace if necessary**)
- 2 – Bracket for final drive
- 3 – Fastening screws (**replace**)

Required parts and materials

Parts Info:	Part No.	Designation – Location	Qty.
	PAF008637	⇒ Hexagon-head bolt, M10 x 26 – Bracket to all-wheel final drive	2 ea.
	PAF008660	⇒ Hexagon nut, M10 – Bracket for final drive to body – Transmission support to body	6 ea.
	N 10629602	⇒ Hex flange bolt, M10 x 35 – Rear final drive bracket to body	4 ea.

PAF107190	⇒ Collared cheese head bolt – Drive shaft to final drive	12 ea.
9P1407306	⇒ Plate – Drive shaft to final drive	6 ea.
992521225	⇒ Boot – Cardan shaft	1 ea.
PAF911439	⇒ Cheese head bolt, M8 x 16 – Cardan shaft to transmission (PDK)	4 ea.
PAF009267	⇒ Hexagon-head bolt, M10 x 40 – Transmission longitudinal member to body	4 ea.

Additional parts required if the all-wheel final drive has to be replaced:

PAB409505	⇒ All-wheel final drive, complete – Front-axle final drive	1 ea.
-----------	---	-------

Materials: **Required materials** (usually already available at the Porsche dealer):

Part No.	Designation – Use	Qty.
00004330516	⇒ Coolant additive, 20-litre container – All-wheel final drive, cooling system	As much as required (approx. 1 litre required per vehicle)

Required tools

- Tools:
- Suitable transmission and engine jack, e.g. **VAS 6931 Engine and gearbox jack**
 - Support plate for engine and gearbox jack, e.g. **VAS 6867 support plate**
 - Strapping belts for securing the final drive, e.g. **9454 - strapping belts**
 - Suitable hose clamps for coolant hoses, e.g. **3093 - hose clamp** or **3094 - hose clamp**
 - **9910 - Release screw** for parking lock on PDK transmission
 - **9255 - Assembly sleeve** for cardan shaft
 - Torque screwdriver, 1.5–3 Nm (1–2 ftlb.), e.g. **VAS 6494 Torque screwdriver, 1.5-3.0 Nm (1-2 ftlb.)**
 - Torque wrench, 2–10 Nm (1.5–7.5 ftlb.), e.g. **VAG 1783 Torque wrench, 2-10 Nm (1.5-7.5 ftlb.)**
 - Torque wrench, 6–50 Nm (4.5–37 ftlb.), e.g. **VAG 1331A Torque wrench, 6-50 Nm (4.5-37 ftlb.)**
 - Torque wrench, 40–200 Nm (30–148 ftlb.), e.g. **VAG 1332 Torque wrench, 40-200 Nm (30-148 ftlb.)**
 - Electronic torque angle torque wrench, 2-100 Nm (1.5-74 ftlb.), e.g. **9768 - Electronic torque wrench, 2 - 100 Nm (1.5 - 74 ftlb.)**

- Electronic torque angle torque wrench, 20-400 Nm (15-296 ftlb.), e.g. **VAS 6942 Torque angle torque wrench, 20-400 Nm (15-296 ftlb.) or equivalent**
- Flashlight (commercially available)

Removing all-wheel final drive and re-screwing bracket for final drive

- Work Procedure: 1 Raise the vehicle using a lifting platform ⇒ *Workshop Manual '4X00IN Lifting the vehicle'*.
- 2 Remove underbody covers.
- 2.1 Remove cover for front underbody ⇒ *Workshop Manual '519219 Removing and installing front cover'*.
- 2.2 Remove cover for center underbody ⇒ *Workshop Manual '519319 Removing and installing centre cover'*.
- 2.3 Remove cover for rear underbody ⇒ *Workshop Manual '519419 Removing and installing rear cover'*.

NOTICE

Lowering all-wheel final drive instead of removing it

- Risk of damage to the cardan shaft
 - Risk of damage to the cardan joints
 - Risk of damage to the drive shafts
- ⇒ Always remove cardan shaft and loosen drive shafts at the final drive.
- ⇒ Remove all-wheel final drive completely.
- ⇒ Never lower the final drive with cardan shaft and drive shafts installed.

- 3 Remove cardan shaft ⇒ *Workshop Manual '390219 Removing and installing cardan shaft'*.
- 4 Remove front-axle support ⇒ *Workshop Manual '400819 Removing and installing front-axle support'*.
- 5 Remove the all-wheel final drive ⇒ *Workshop Manual '398819 Removing and installing all-wheel final drive'*.



Information

The fastening screws can loosen over the service life of the vehicle because the all-wheel final drive bracket was not tightened according to specifications.

If one or both fastening screws have loosened, this can damage the final drive and also cause damage to adjacent components.

The **threaded joint** must therefore be **checked** after removing the final drive.

Further work may then be required, depending on the result of the check.

6 Check threaded joint on front bracket for final drive.



CAUTION

Heavy components

- Risk of pinching

⇒ Wear personal protective gear.

⇒ Get someone to help if necessary.

6.1 Place final drive on a suitable workbench. Get another person to help you secure the final drive.

6.2 **Check threaded joint on front bracket** for final drive and then loosen the bracket ⇒ *Threaded joint for final drive bracket -1-* at the all-wheel final drive.

To do this, **measure the loosening torque** of the fastening screws ⇒ *Threaded joint for final drive bracket -2-* using **9768 - electronic torque wrench, 2 - 100 Nm (1.5 - 74 ftlb.)** or a similar torque wrench.

- The **loosening torque of both screws is at least 3 Nm (2 ftlb.)**: The fastening screws have **not loosened**. Continue with **Step 6.3**.

- If the **loosening torque of one of the two screws is less than 3 Nm (2 ftlb.)**, the **all-wheel final drive must be replaced**. To do this, continue with ⇒ *Technical Information '398819 Replacing all-wheel final drive and checking vehicle for damage'*.

6.3 Unscrew fastening screws ⇒ *Threaded joint for final drive bracket -2-* fully and remove them.

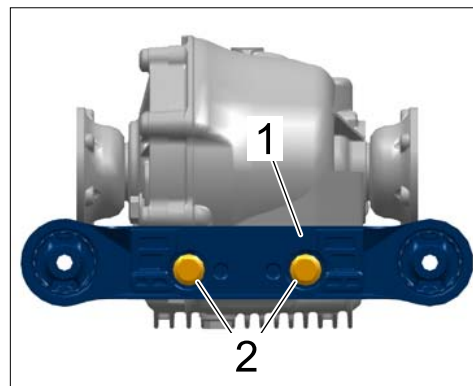

Threaded joint for final drive bracket

- 6.4 Secure bracket ⇒ *Threaded joint for final drive bracket -1-* with **new fastening screws** on the all-wheel final drive.

Tightening torque 65 Nm (48 ftlb.)

Part No.	Designation	Qty.
PAF008637	Hexagon-head bolt, M10 x 26	2 ea.

- 7 Install the all-wheel final drive ⇒ *Workshop Manual '398819 Removing and installing all-wheel final drive'*.
- 8 Install front-axle support ⇒ *Workshop Manual '400819 Removing and installing front-axle support'*.
- 9 Install cardan shaft ⇒ *Workshop Manual '390219 Removing and installing cardan shaft'*.
- 10 Install underbody covers.
- 10.1 Install cover for rear underbody ⇒ *Workshop Manual '519419 Removing and installing rear cover'*
- 10.2 Install cover for center underbody ⇒ *Workshop Manual '519319 Removing and installing centre cover'*.
- 10.3 Install cover for front underbody ⇒ *Workshop Manual '519219 Removing and installing front cover'*.
- 11 Lower the vehicle and remove it from the lifting platform.
- 12 Enter the campaign in the Warranty and Maintenance booklet.

End of action required

For warranty processing, see **Scope 1** under ⇒ *Technical Information '519219 Warranty processing'*.

Replacing all-wheel final drive and checking vehicle for damage



Information

If one or both fastening screws on the bracket for the all-wheel final drive have loosened, the final drive can move out of its installation position.

This can result in damage to the final drive and adjacent components such as the fuel tank or the drive shafts can also be damaged.

The **final drive must therefore be replaced** in this case.

In addition, the vehicle must be **checked for signs of damage** around the final drive installation position and the damaged parts must be replaced if necessary.

Work Procedure: 1 Perform a visual inspection around the installation position of the final drive to see whether there are signs of damage on the vehicle.

Always **pay particular attention to the following points:**

1.1 **Check the fuel tank** ⇒ *Checking fuel tank for damage -1-* for grinding and chafing marks caused by contact with the drive shaft flanges ⇒ *Checking fuel tank for damage -2-* and/or the final drive.

If **grinding or chafing marks** ⇒ *Checking fuel tank for damage -Arrows-* are visible, the **fuel tank must be replaced.**

For instructions, see ⇒ *Workshop Manual '201019 Removing and installing fuel tank'.*

Additional parts required for this: see Porsche Parts Catalogue - PET.

1.2 **Check drive shafts** ⇒ *Checking drive shafts for damage -2-* for grinding and chafing marks caused by contact with the fastening points on the body side of the final drive and/or the fuel tank ⇒ *Checking drive shafts for damage -1-*.

If **grinding or chafing marks** ⇒ *Checking drive shafts for damage -Arrows-* are visible, the relevant **drive shaft must be replaced.**

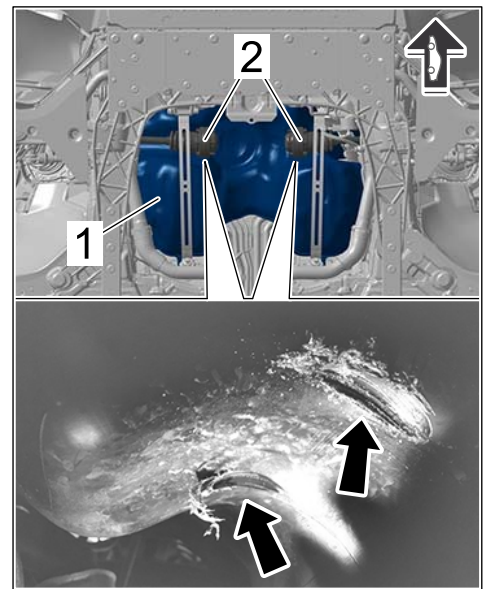

Checking fuel tank for damage

For instructions, see ⇒ *Workshop Manual '404119 Removing and installing front drive shaft'*.

Additional parts required for this: see Porsche Parts Catalogue - PET.

- 2 **Install new** all-wheel final drive ⇒ *Workshop Manual '398819 Removing and installing all-wheel final drive'*.



Information

Please note:

The **bracket for final drive** is already **installed and secured correctly** on the new all-wheel final drive. The bracket that previously became loose on the original all-wheel final drive is therefore **not required**.

- 3 Install front-axle support ⇒ *Workshop Manual '400819 Removing and installing front-axle support'*.
- 4 Install cardan shaft ⇒ *Workshop Manual '390219 Removing and installing cardan shaft'*.
- 5 Install underbody covers.
 - 5.1 Install cover for rear underbody ⇒ *Workshop Manual '519419 Removing and installing rear cover'*
 - 5.2 Install cover for center underbody ⇒ *Workshop Manual '519319 Removing and installing centre cover'*.
 - 5.3 Install cover for front underbody ⇒ *Workshop Manual '519219 Removing and installing front cover'*.

- 6 Lower the vehicle and remove it from the lifting platform.
- 7 Enter the campaign in the Warranty and Maintenance booklet.

End of action required

If **only** the all-wheel final drive was replaced, see **Scope 2** under ⇒ *Technical Information '519219 Warranty processing'* for information on warranty processing.

If **other signs of damage** were found on the vehicle, please read the **information on warranty processing** for the required parts and working time at the end of this Technical Information.

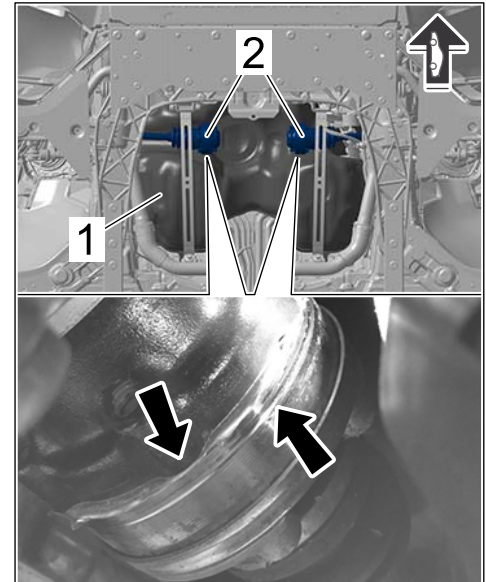

Checking drive shafts for damage

Warranty processing

Scope 1: **Checking all-wheel final drive and re-screwing final drive** – the final drive does **not** have to be replaced

Working time:

Checking threaded joint on all-wheel final drive and re-screwing final drive Labor time: **535 TU**

- Includes:
- Raising and lowering the vehicle
 - Removing and installing cover for front underbody
 - Removing and installing cover for center underbody
 - Removing and installing cover for rear underbody
 - Removing and installing cardan shaft
 - Removing and installing front-axle support
 - Removing and installing all-wheel final drive

Parts required:

PAF008637	Hexagon-head bolt, M10 x 26	2 ea.
PAF008660	Hexagon nut, M10	6 ea.
N 10629602	Hex flange bolt, M10 x 35	4 ea.
PAF107190	Collared cheese head bolt	12 ea.
9P1407306	Plate	6 ea.
992521225	Boot	1 ea.
PAF911439	Cheese head bolt, M8 x 16	4 ea.
PAF009267	Hexagon-head bolt, M10 x 40	4 ea.

Required materials:

00004330516	Coolant additive, 20-litre container	0.05 ea.
-------------	--------------------------------------	----------

⇒ Damage Code ALA8 099 000 1

Scope 2:

Checking all-wheel final drive and replacing final drive

Working time:

Checking threaded joint on all-wheel final drive and replacing final drive Labor time: **540 TU**

- Includes:
- Raising and lowering the vehicle
 - Removing and installing cover for front underbody
 - Removing and installing cover for center underbody
 - Removing and installing cover for rear underbody
 - Removing and installing cardan shaft
 - Removing and installing front-axle support
 - Removing all-wheel final drive
 - Installing new all-wheel final drive
 - Checking vehicle for damage

Without: Replacing fuel tank
Replacing drive shafts

Parts required:

PAB409505	All-wheel final drive, complete	1 ea.
PAF008637	Hexagon-head bolt, M10 x 26	2 ea.
PAF008660	Hexagon nut, M10	6 ea.
N 10629602	Hex flange bolt, M10 x 35	4 ea.
PAF107190	Collared cheese head bolt	12 ea.
9P1407306	Plate	6 ea.
992521225	Boot	1 ea.
PAF911439	Cheese head bolt, M8 x 16	4 ea.
PAF009267	Hexagon-head bolt, M10 x 40	4 ea.

Required materials:

00004330516	Coolant additive, 20-litre container	0.05 ea.
-------------	--------------------------------------	----------

⇒ Damage Code ALA8 099 000 2

Information: **Information on warranty processing if the fuel tank and/or drive shaft(s) were replaced:**

Due to the small number of vehicles involved and the low expected replacement quota, replacement of the fuel tank and drive shafts is **not part** of this campaign.

For this reason, please send the **following information** about the relevant vehicle to PCNA Warranty via PRMS for warranty processing for this measure, if necessary:

- Vehicle identification number (VIN)
- Repair date
- Photos of damage to the fuel tank or to the drive shafts
- List of parts used including part numbers

You will then receive further information on warranty processing based on your feedback.

Scope 1 or 2 must not be invoiced in this case.

Important Notice: Technical Bulletins issued by Porsche Cars North America, Inc. are intended only for use by professional automotive technicians who have attended Porsche service training courses. They are written to inform those technicians of conditions that may occur on some Porsche vehicles, or to provide information that could assist in the proper servicing of a vehicle. Porsche special tools may be necessary in order to perform certain operations identified in these bulletins. Use of tools and procedures other than those Porsche recommends in these bulletins may be detrimental to the safe operation of your vehicle, and may endanger the people working on it. Properly trained Porsche technicians have the equipment, tools, safety instructions, and know-how to do the job properly and safely. Part numbers listed in these bulletins are for reference only. The work procedures updated electronically in the Porsche PIWIS diagnostic and testing device take precedence and, in the event of a discrepancy, the work procedures in the PIWIS Tester are the ones that must be followed.

© 2020 Porsche Cars North America, Inc.