



Mercedes-Benz

Campaign No. 2020070017, August 2020

TO: ALL MERCEDES-BENZ CENTERS

SUBJECT: **Model C-Class, E-Class, and GLC-Class vehicles (205, 213, 253 platform)
Model Year 2020
Torque Value of Exhaust Turbocharger Screws**

Mercedes-Benz AG, ("MBAG") the manufacturer of Mercedes-Benz vehicles, has determined that on certain Model Year ("MY") 2020 C-Class, E-Class, and GLC-Class vehicles (205, 213, 253 platform) equipped with a 4-cylinder gasoline engine (M264), the screws that retain the turbocharger oil feed and return lines may not have been properly torqued during the assembly process due to a deviation in the data documentation. As a result, the correct mounting of the assembly cannot be confirmed. Should the mounting assembly not meet the torque specification, the turbocharger oil feed and return lines could detach and leak oil, which could potentially contact hot engine components, increasing the risk of a fire. MBUSA will conduct a voluntary recall. An authorized Mercedes-Benz dealer will check the mounting of the turbocharger oil feed and oil return line on the affected vehicles and rework it, if necessary.

Prior to performing this Recall Campaign:

- **VMI must always be checked before performing campaigns to verify that the campaign is required on a specific vehicle. Always check for any other open campaigns, and perform accordingly.**
- Please review the entire Recall Campaign bulletin and follow the repair procedure exactly as described.

Please note that Recall Campaigns **do not expire** and may also be performed on a vehicle with a vehicle status indicator.

Approximately 88 vehicles are involved.

Order No. P-RC-2020070017

This bulletin has been created and maintained in accordance with MBUSA-SLP S423QH001, Document and Data Control, and MBUSA-SLP S424HH001, Control of Quality Records.

i Code M005 corresponds to "Vehicles with 4MATIC/ALL-WHEEL DRIVE"

Procedure

1. Remove air intake pipe downstream of air filter (in model 205, 213, and 253 with **M264**).
 - i** For basic data, see **AR09.10-P-8131MRI** (model 205/253).
 - i** For basic data, see **AR09.10-P-8131MRH** (model 213).
2. Remove right charge air line upstream of charge air cooler (in model 205, 213, and 253 with **M264**).
 - i** Only remove charge air line, do **not** drain coolant and do **not** remove charge air cooler.
 - i** For basic data, see **AR09.41-P-6817MRI** (model 205/253).
 - i** For basic data, see **AR09.41-P-6817MRH** (model 213).
3. Release coolant pump and slide towards front with connected lines (in model 205, 213, and 253 with **M264** and **without code M005**).
 - i** Due to the "sliding towards front" of the coolant pump, the access to the screws of the oil return feed line is ensured.
 - i** For basic data, see **AR20.10-P-1271MRI** (model 205/253).
 - i** For basic data, see **AR20.10-P-1271MRH** (model 213).
4. Underneath the exhaust gas turbocharger (**A, figure 1**), unscrew the screws (**C, figure 1**) and remove the bracket (**B, figure 1**) (in model 205, 213, and 253 **with M264**).
 - i** For basic data, see **AR09.40-P-6036MRI** (model 205/253).
 - i** For basic data, see **AR09.40-P-6036MRH** (model 213).

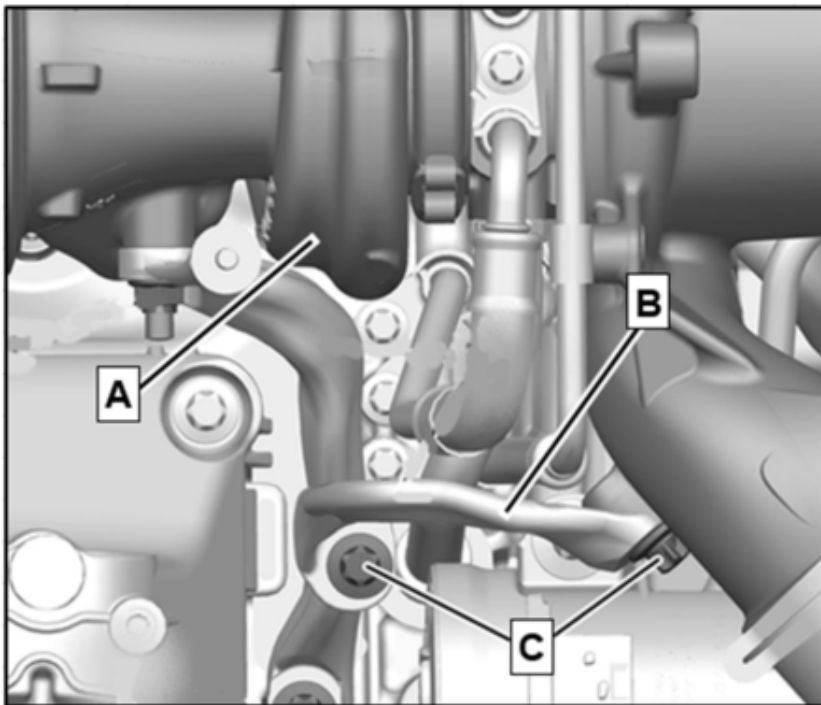

Figure 1

5. Remove front lower engine compartment lining.
 - i** For basic data, see **AR61.20-P-1105LW** (model 205/253).
 - i** For basic data, see **AR61.20-P-1105LWE** (model 213).
6. Retighten screws (**D, figure 2**) of oil feed line (**E, figure 2**) at exhaust gas turbocharger (**A, figure 2**) with **10 Nm**.
7. Retighten screws (**F, figure 2**) of oil return feed line (**G, figure 2**) at exhaust gas turbocharger (**A, figure 2**) with **10 Nm**.

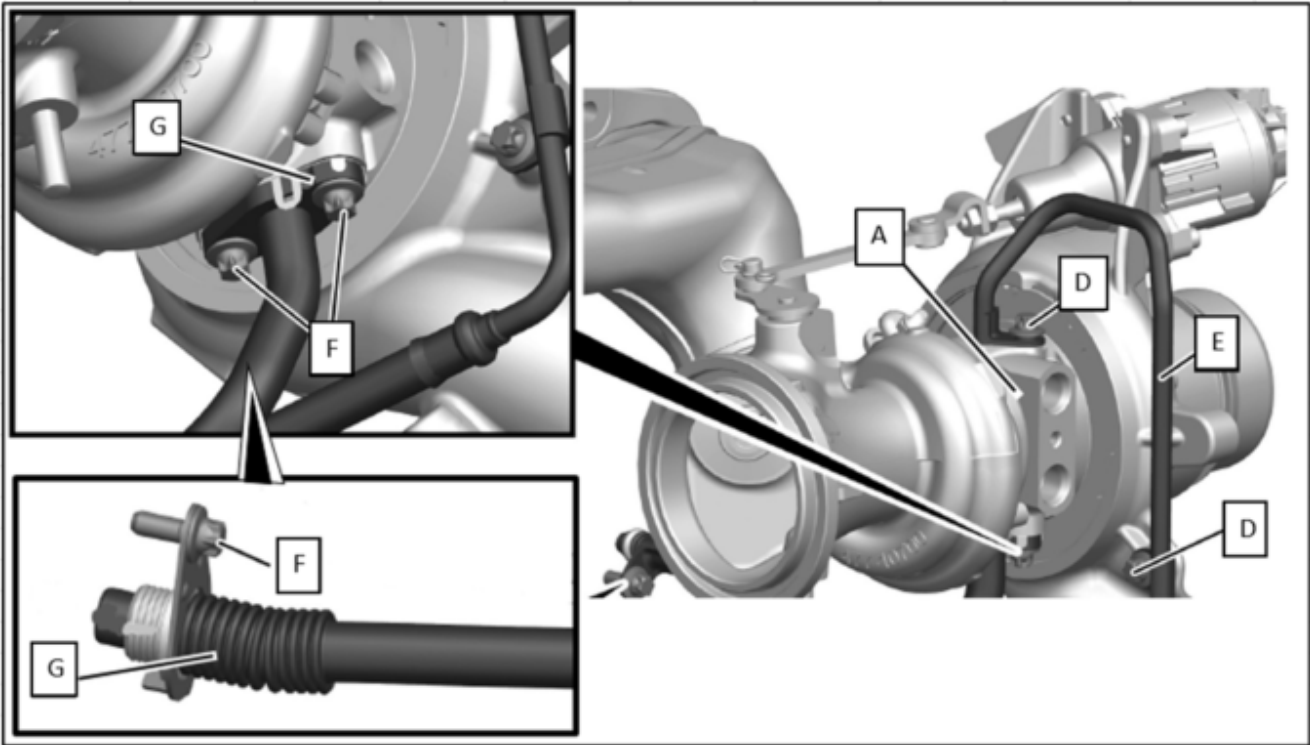

Figure 2

8. Assemble in reverse order.

Warranty Information

Operation: Correct torque of threaded connection for exhaust gas turbocharger oil lines (02-1625)

Damage Code	Operation Number	Labor Time (hrs.)
09 931 03 08	02-1625 (model 205, 213, and 253 with M264)	1.3
	02-1625 (model 205, 213, and 253 with M264 and with code M005)	1.1

i Note
 Operation Number labor times are subject to change.