



Revision (2) July 2020

Dealer Service Instructions for:

## **Safety Recall W46 / NHTSA 20V-334 12-Volt Isolator Post Connection**

**These are the Final repair remedy instructions. All content contained in this document is to be considered NEW, please read carefully.**

**NOTE: Steps 6 and 8 on page 30 have been revised.**

**Remedy Available**

**2017-2020 (RU) Chrysler Pacifica PHEV**

*NOTE: This campaign applies only to the above Plug-In Hybrid Electric Vehicles (PHEV)*

*NOTE: Some vehicles above may have been identified as not involved in this recall and therefore have been excluded from this recall.*

**IMPORTANT: Some of the involved vehicles may be in dealer new vehicle inventory. Federal law requires you to complete this recall service on these vehicles before retail delivery.** Dealers should also consider this requirement to apply to used vehicle inventory and should perform this recall on vehicles in for service. Involved vehicles can be determined by using the VIP inquiry process.

## **Subject**

In some circumstances, the 12-volt isolator post on about 23,000 of the above vehicles may experience a high resistance electrical connection due to inadvertent liquid intrusion. High resistance electrical connections can lead to prolonged heating and a potential vehicle fire with the vehicle on or off. A vehicle fire may increase the risk of injury to occupants and persons outside of the vehicle, as well as property damage.

It is advised to exercise the following precautions until the vehicle has the final repair completed: do not park these vehicles inside of buildings or structures and avoid parking near other vehicles. In addition, keep liquids out of the backseat area, including but not limited to beverages, wet items, umbrellas, or bottled liquids that may leak.

## **Repair**

Install a gasket under the 12-volt isolator. Inspect the 12-volt isolator post connection joint. In the event the joint is compromised, the isolator and 12-volt electrical cables will require replacement.

## **Alternate Transportation**

Dealers should attempt to minimize customer inconvenience by placing the owner in a loaner vehicle if the vehicle must be held overnight.

**Parts Information**

<u>Part Number</u>	<u>Description</u>
<b>CSALW462AA</b>	<b>Gasket Kit</b>

Each package contains the following components:

<u>Quantity</u>	<u>Description</u>
1	Foam Gasket for Isolator

**Parts Return**

No parts return required for this campaign.

**Special Tools**

**The following special tools are required to perform this repair:**

- NPN wiTECH MicroPod II
- NPN Laptop Computer
- NPN wiTECH Software
- NPN Multimeter
- 10084 / 2035110082 Cover, Terminal Protective
- 2035101082 Cover, HEV Battery Terminal

<b>Service Procedure</b>
--------------------------

***This procedure must be performed by a PHEV trained technician.***

**WARNING:** When performing any repairs that involve contact with high voltage components or systems, the technician performing repairs on the vehicle must verify that the system remains powered down during high voltage repairs. Strictly adhere to the following procedures:

- To ensure that the vehicle is properly powered down, remove the service disconnect.
- The technician must always know the location of the service disconnect throughout the repair.
- The technician must ensure that no one reconnects the service disconnect while service is being performed.
- Any time the vehicle is unattended, prior to continuing with repair work, the technician must recheck that the service disconnect has not been reinstalled.

**NOTE:** Because the high-voltage battery is used to charge the 12-volt battery via the Auxiliary Power Module (APM), disconnecting the 12-volt battery negative cable will not power down the 12-volt system. The following **12-Volt Power Down** procedure **MUST** be performed before any repairs, disassembly, or testing down are carried out.

**NOTE:** Even though the high-voltage battery manual service disconnect is removed during the 12-Volt Power Down procedure, the 12-Volt Power Down procedure will NOT safely and reliably power down the high-voltage system. If any high-voltage components are to be accessed, disconnected or tested, the High-Voltage Power Down procedure must first be carried out.

**NOTE:** The following W46 service procedure requires power down of the 12-volt system only. However, if any high-voltage components not related to the following W46 service procedure are to be accessed, disconnected or tested, the High-Voltage Power Down procedure must first be carried out.

**Service Procedure [Continued]****A. 12-Volt Power Down**

1. Position the vehicle on a suitable hoist which will allow access to the belly pan for removal later in this procedure.
2. Position the driver seat fully forward for improved access to the 12-volt isolator post connection (Figure 1).

**Figure 1 – Position Driver Seat Forward**

3. Open the left side sliding door for access to the high-voltage manual service disconnect.
4. Open the rear liftgate for access to the 12-volt battery.

**NOTE: Position driver seat forward and open vehicle doors prior to powering down the electrical system.**

**Figure 2 – Stow Left Third Row Seat**

5. Stow the left third row seat down into the floor as shown (Figure 2).

**NOTE: Vehicles equipped with power third row Stow 'n Go seats must have left third row seat stowed in the floor as described in Step 5 (Figure 2). Depending on repair direction later in this procedure, it may be necessary to access the left rear quarter trim panel while the electrical system is powered down.**

**Service Procedure [Continued]**

6. Turn the ignition to the **OFF** position, and **WAIT FIVE MINUTES** to allow the high-voltage system to shut down without setting a fault code.

7. Remove the 12-volt battery access cover from the left rear quarter trim panel (Figure 3).

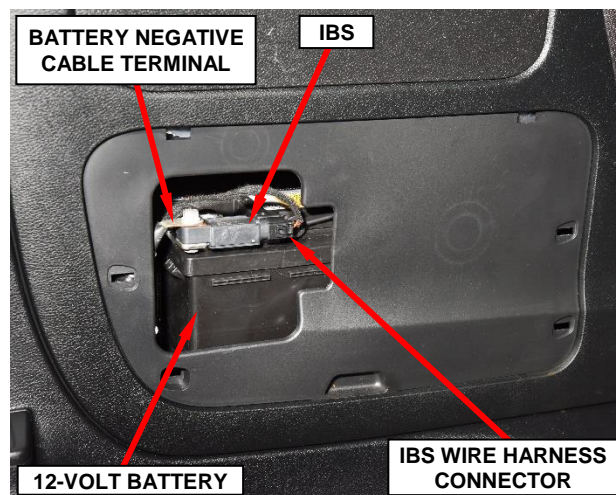


**Figure 3 – Battery Access Cover**

8. Disconnect the wire harness connector from the Intelligent Battery Sensor (IBS) (Figure 4).

9. Remove the nut securing the battery negative cable terminal to the IBS (Figure 4).

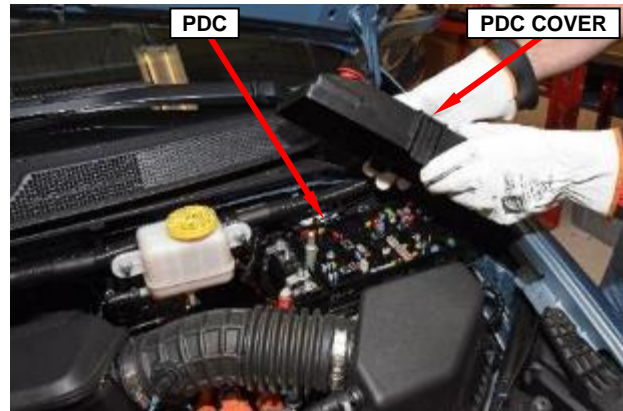
10. Disconnect and isolate the battery negative cable terminal from the IBS (Figure 4).



**Figure 4 – Battery Negative Cable**

**Service Procedure [Continued]**

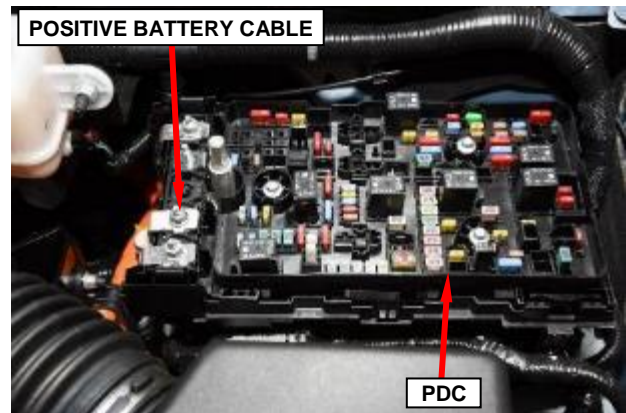
11. Open the hood for 12-volt Power Distribution Center (PDC) access.



**Figure 5 – Power Distribution Center**

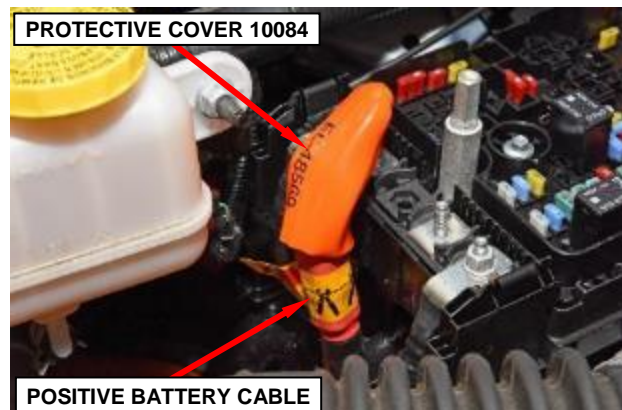
12. Remove the 12-volt Power PDC cover (Figure 5).

13. Remove the nut securing the positive battery cable, then disconnect the positive battery cable from the 12-volt PDC (Figure 6).



**Figure 6 – Positive Battery Cable**

14. Isolate the positive battery cable terminal with protective cover 10084 (2035110082 equivalent) (Figure 7).



**Figure 7 – Cover Cable Terminal**

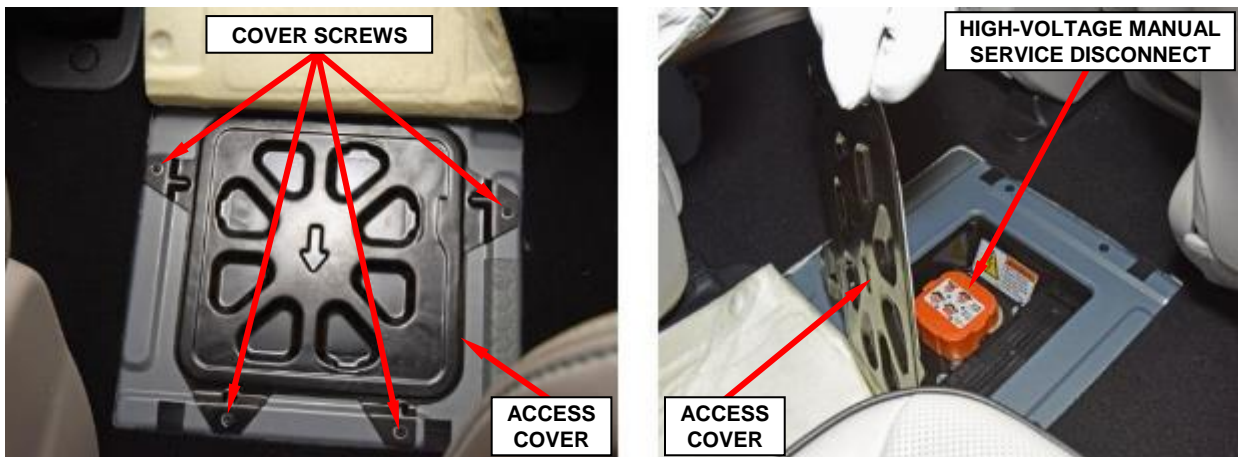
**Service Procedure [Continued]**

- 15. Lift the carpet away from the high-voltage manual service disconnect access cover (Figure 8).



**Figure 8 – Vehicle Carpet**

- 16. Remove the four screws securing the high-voltage manual service disconnect access cover to the floor then remove the cover (Figure 9).



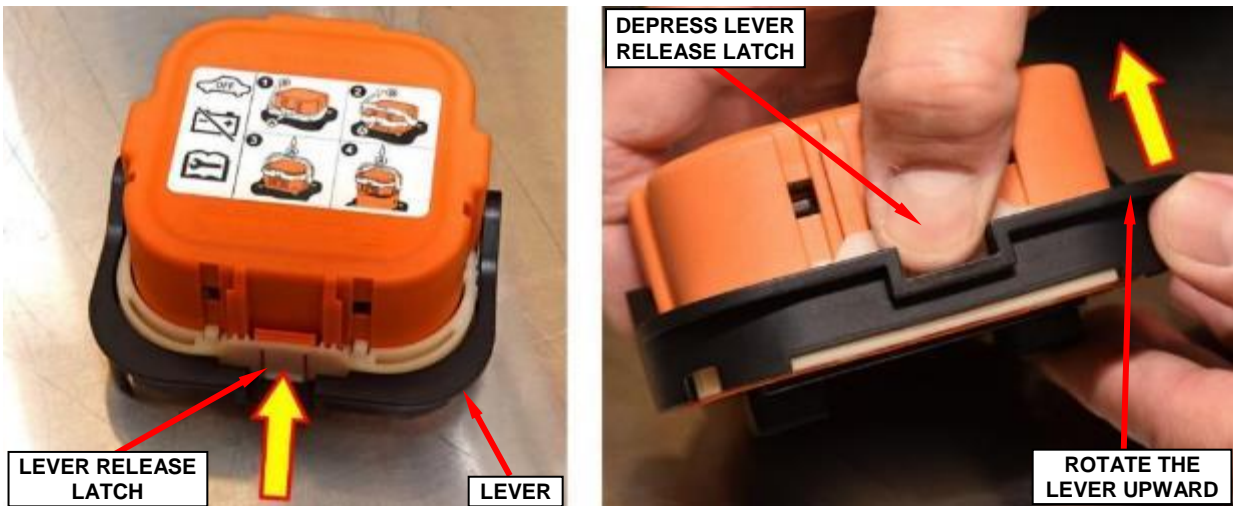
**Figure 9 – High-Voltage Manual Service Disconnect Access Cover**



**Service Procedure [Continued]**

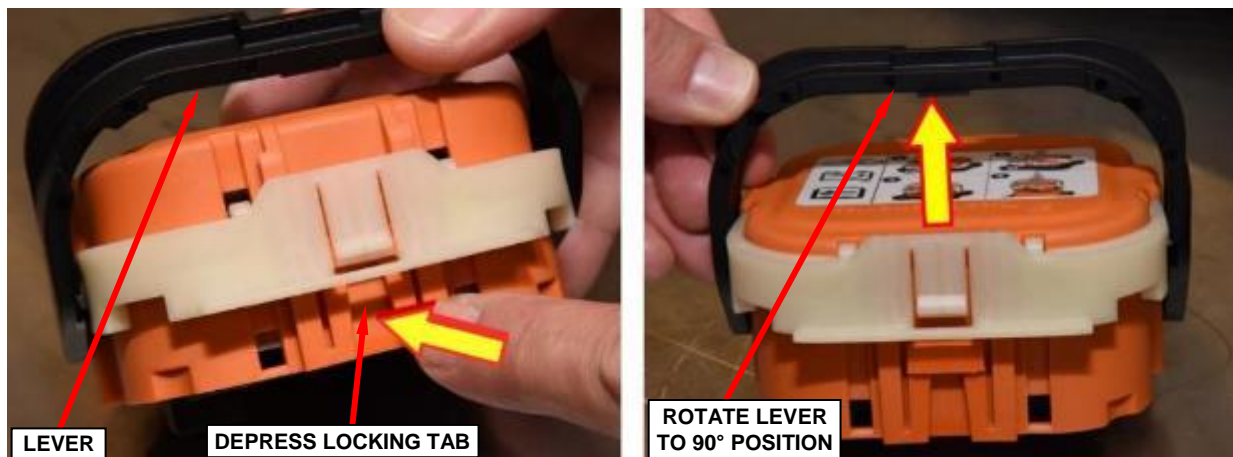
- Depress the lever release latch firmly. With the latch fully depressed, rotate the lever upward. The lever will stop at the 45° position (Figure 10).

**NOTE: At this stage, the High Voltage Inter-Lock (HVIL) connection has been broken and the circuit is de-energized.**



**Figure 10 – High-Voltage Manual Service Disconnect First Stage Latch Release (High-Voltage Manual Service Disconnect Removed from Vehicle for Visual Clarity)**

- Depress the locking tab and continue to rotate the lever to the end of travel, 90° position (Figure 11).



**Figure 11 – High-Voltage Manual Service Disconnect Second Stage Latch Release (High-Voltage Manual Service Disconnect Removed from Vehicle for Visual Clarity)**

**Service Procedure [Continued]**

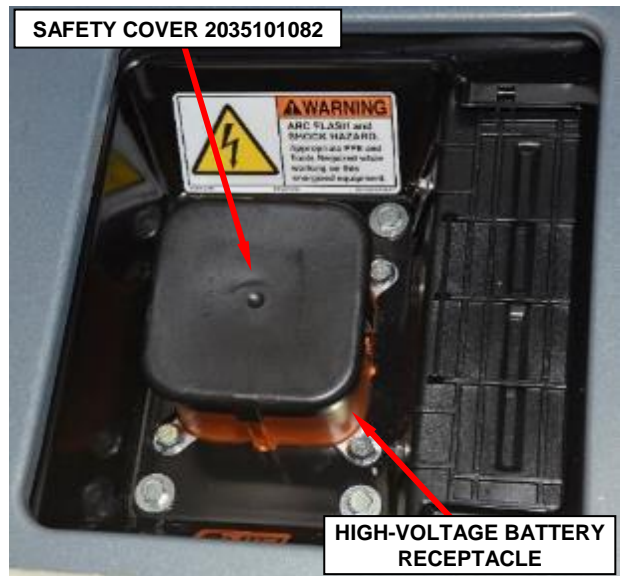
19. Pull straight up on the service disconnect lever to disengage and remove the high-voltage manual service disconnect from the receptacle (Figure 12).

**NOTE:** Make sure the location of the high-voltage manual service disconnect is always known after removal. It is best practice to place the high-voltage manual service disconnect in a highly visible location when removed.



**Figure 12 – High-Voltage Manual Service Disconnect and Receptacle**

20. Cap the receptacle on the high-voltage battery with safety cover 2035101082 to prevent foreign objects from entering the receptacle (Figure 13).



**Figure 13 – High-Voltage Battery Receptacle Safety Cover**

21. Check the 12-Volt system at the Power Distribution Center (PDC) with a multimeter to ensure there is less than 1-Volt present. If so, the 12-volt electrical system is now powered down.

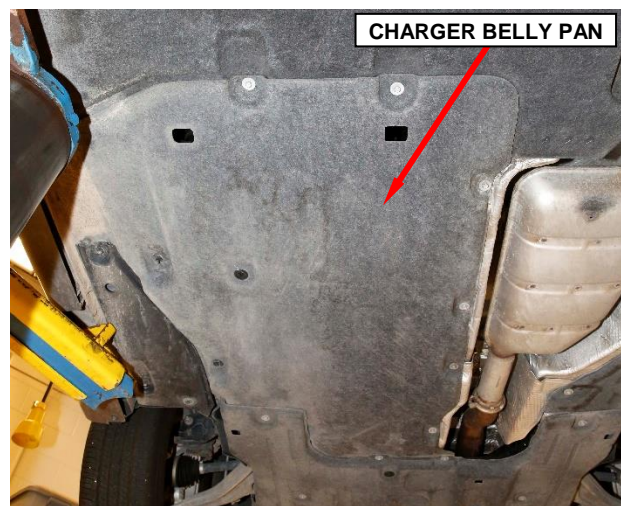
**NOTE:** A small voltage reading of less than 1-Volt is to be expected as system capacitors slowly discharge. If more than 1-Volt is still present, contact the STAR Center for service support before proceeding.

**Service Procedure [Continued]****B. 12-Volt Isolator Connection Inspection**

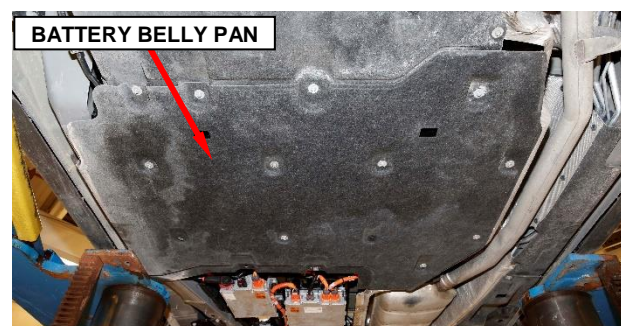
1. Raise and support the vehicle.
2. Remove the fasteners then remove the left side closeout panel overlapping the charger belly pan (Figure 14).

**Figure 14 – Belly Pan Closeout Panel**

3. Remove the fasteners then remove the charger belly pan (Figure 15).

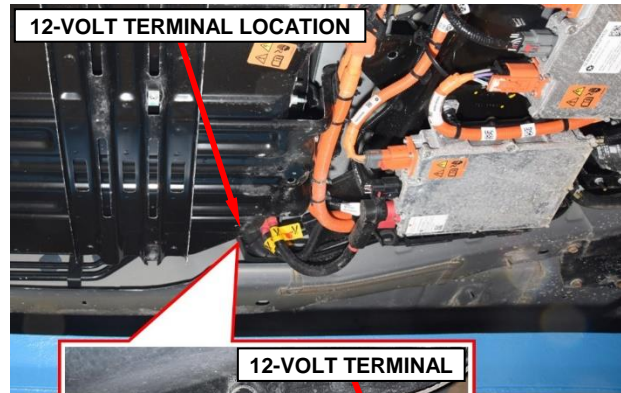
**Figure 15 – Charger Belly Pan**

4. Remove the fasteners then remove the battery belly pan (Figure 16).

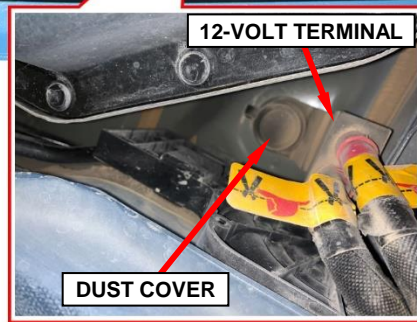
**Figure 16 – Battery Belly Pan**

**Service Procedure [Continued]**

5. 12-volt cable underbody connector location (Figure 17).

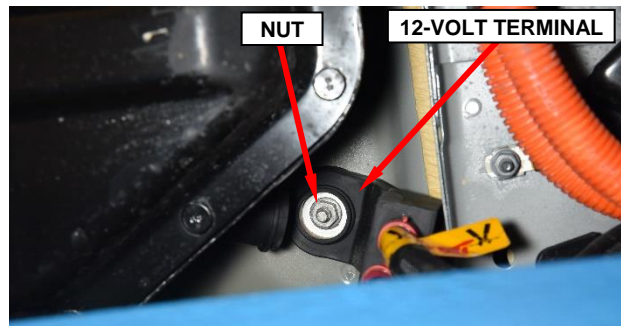


6. Release the dust cover from the 12-volt cable terminal (Figure 17).



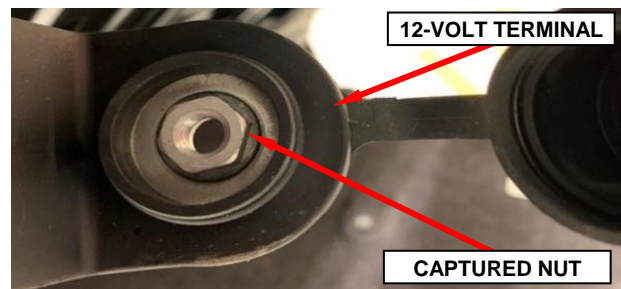
**Figure 17 – 12-Volt Cable Underbody Connector Location**

7. Loosen the nut and remove the 12-volt terminal and nut assembly from the isolator post (Figure 18).



**Figure 18 – 12-Volt Cable Terminal**

**NOTE: Nut is captured to the terminal (Figure 19).**



**Figure 19 – Captured Nut**

**Service Procedure [Continued]**

8. Inspect the 12-volt cable terminal for signs of corrosion, oxidation, tarnish, discoloration, dirt, debris, and / or lime (Figure 20).

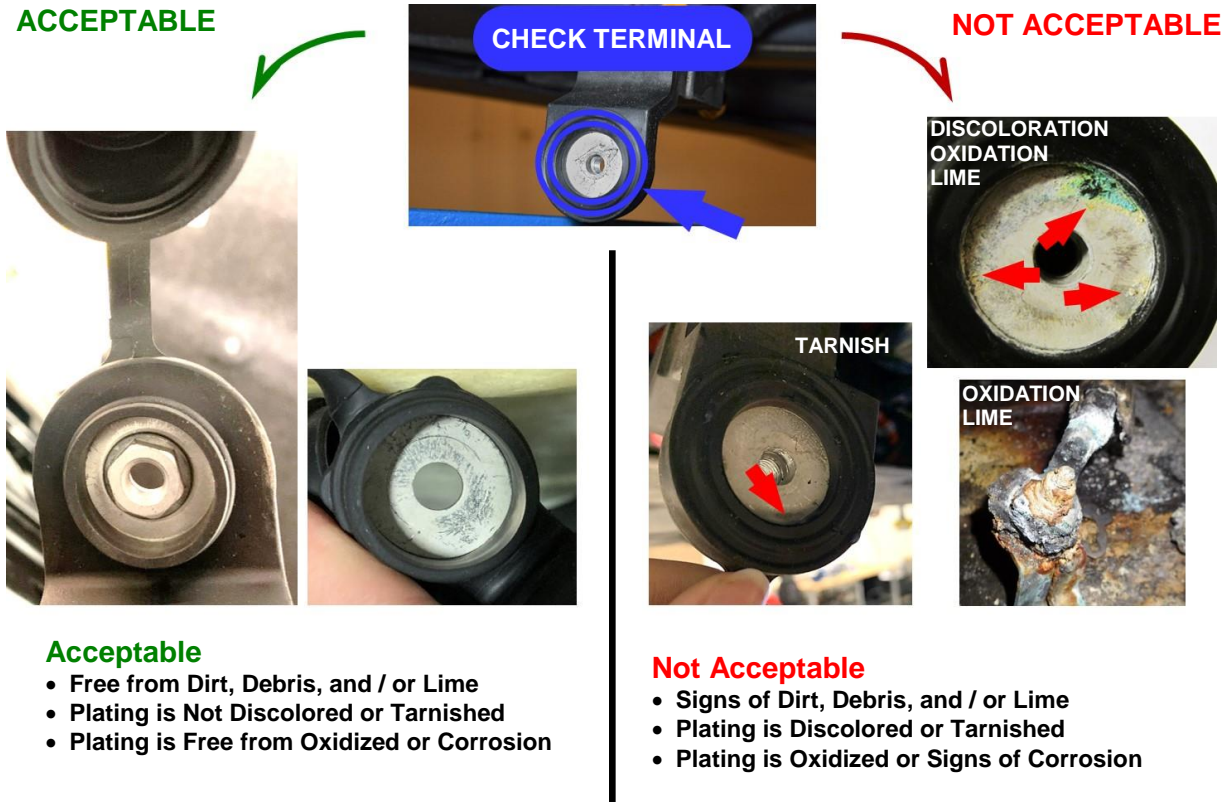


Figure 20 – Inspect 12-Volt Cable Terminal for Acceptability

**Service Procedure [Continued]**

9. Lower the vehicle.

10. Remove the left side rear seat track cover from the driver seat (Figure 21)



**Figure 21 – Seat Track Cover**

11. Remove the rear door sill from the left side rear door opening (Figure 22).



**Figure 22 – Door Sill Rear**

12. Release from the floor but do not fully remove the front door sill from left side rear door opening (Figure 23).

13. Pull back the carpet from behind the front driver seat (Figure 23).



**Figure 23 – Door Sill Front and Carpet**

**Service Procedure [Continued]**

14. Release the dust cover from the 12-volt cable terminal (Figure 24).

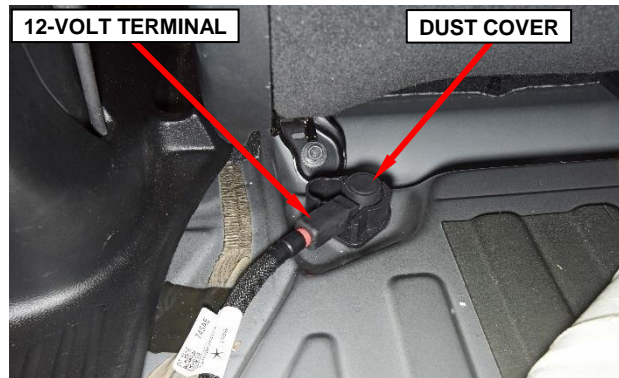


Figure 24 – 12-Volt Terminal Dust Cover

15. Remove the nut from the 12-volt terminal isolator post (Figure 25).

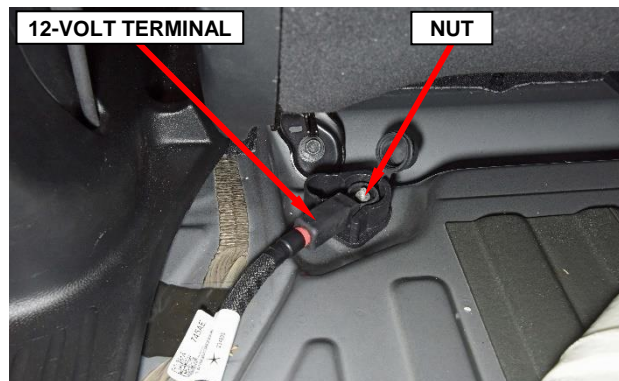


Figure 25 – 12-Volt Cable Terminal

16. Remove the 12-volt terminal from the isolator post (Figure 25).

17. Inspect the 12-volt cable terminal for signs of corrosion, oxidation, tarnish, discoloration, dirt, debris, and / or lime on the terminal same as was done in **Step 8** (Figure 20).

18. Were any signs of corrosion, oxidation, tarnish, discoloration, dirt, debris, and / or lime detected (Figure 20) on either the lower or upper 12-volt cable terminals inspected in **Step 8** or **Step 17**?

- **YES:** If either 12-volt cable terminal shows signs of corrosion, oxidation, tarnish, discoloration, dirt, debris, and / or lime. Both cables and isolator must be replaced. Continue with the service procedure in **Section C** to replace both 12-volt cables, then perform **Section D** for isolator and gasket installation.
- **NO:** Both 12-volt cable terminals do NOT show any signs of corrosion, oxidation, tarnish, discoloration, dirt, debris, and / or lime. Skip **Section C**, cables and isolator will NOT require replacement. Proceed directly to **Section D** for isolator gasket installation.

**Service Procedure [Continued]**

**C. 12-Volt Cables Replacement**

**NOTE:** Section C is applicable **ONLY** for vehicles requiring 12-volt cables replacement due to cable terminal showing signs of corrosion, oxidation, tarnish, discoloration, dirt, debris, and / or lime as illustrated in (Figure 20).

1. Order the cable and isolator kit.

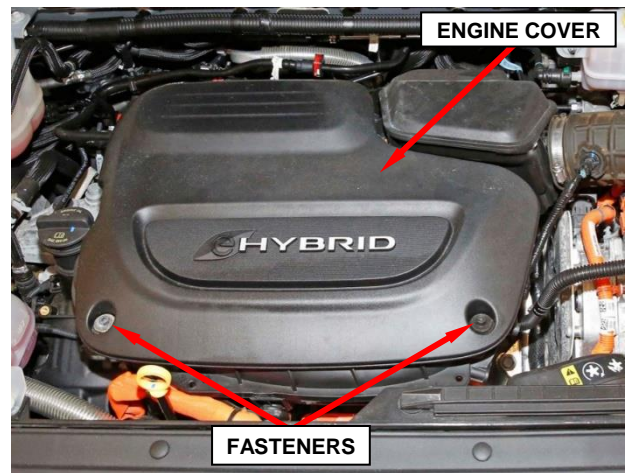
**NOTE:** When submitting the Order Entry for this part, the VIN and Repair Order number **MUST** be included in the comment section.

<u>Part Number</u>	<u>Description</u>
<b>CSALW461AA</b>	<b>Cables and Isolator Kit</b>

Each package contains the following components:

<u>Quantity</u>	<u>Description</u>
1	Exterior 12-Volt Cable assembly
1	Interior 12-Volt Cable assembly
1	12-volt Isolator
1	Nut for Isolator Post
1	Cable Tie for 12-Volt Cable

2. Remove the engine cover fasteners then release the engine cover rubber mount sockets from the locating pins and remove the engine cover from the engine compartment (Figure 26).

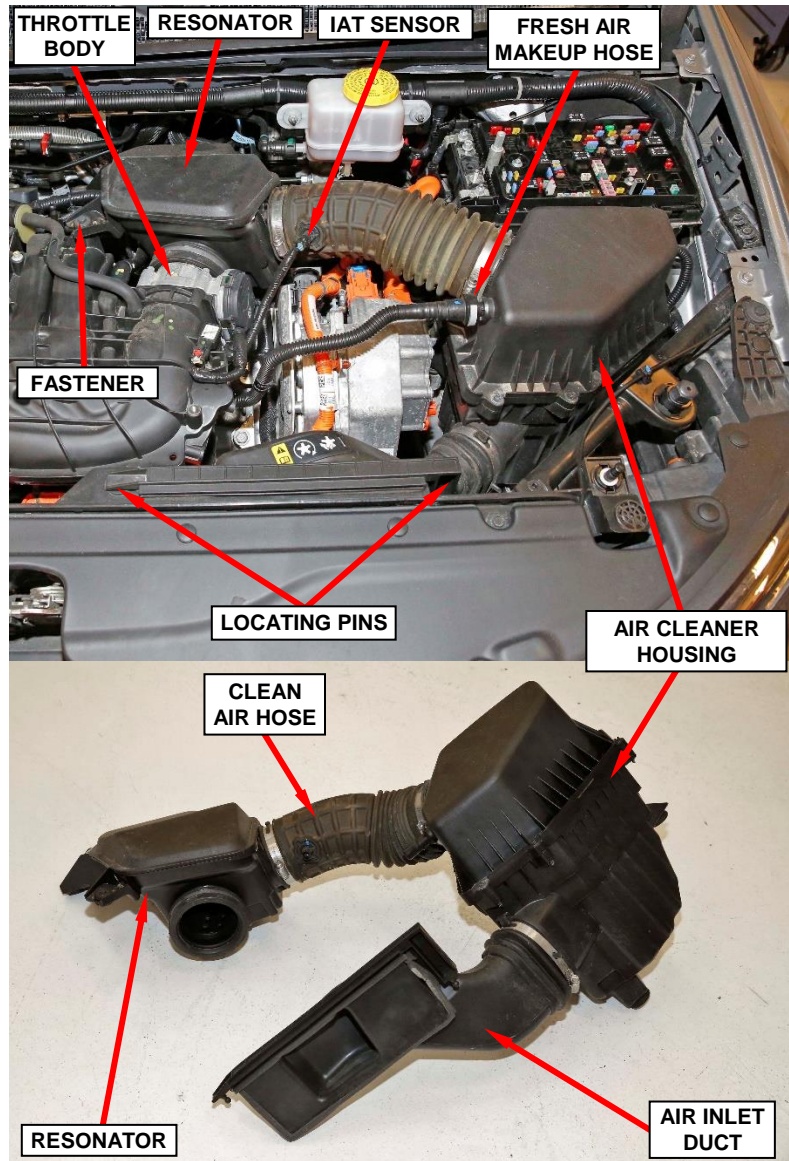


**Figure 26 – Engine Cover**



**Service Procedure [Continued]**

3. Remove the fastener from the resonator (Figure 27).
4. Disconnect the wire harness connector from the Inlet Air Temperature (IAT) sensor (Figure 27).
5. Disconnect the fresh air makeup hose from the air cleaner housing (Figure 27).
6. Disengage the resonator from the throttle body and the locating pins from the rubber mount sockets (Figure 27).
7. Disengage the clean air housing locating pins from the rubber mount sockets (Figure 27).

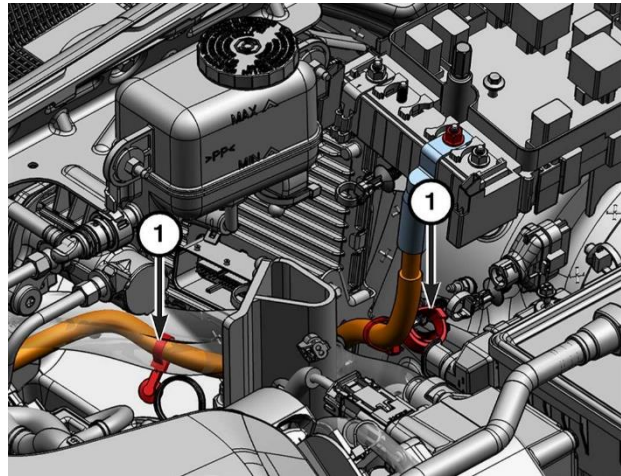


**Figure 27 – Air Intake Assembly**

8. Disengage the air inlet duct locating pins from the rubber mount sockets (Figure 27).
9. Remove the resonator, air cleaner housing, and air inlet duct as an assembly from the engine compartment for 12-volt cable access (Figure 27).

**Service Procedure [Continued]**

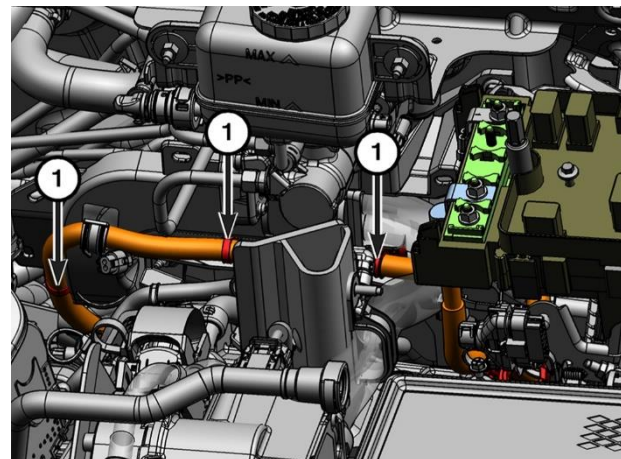
**NOTE:** Pay very close attention to original cable clip locations and cable routing during the removal of the 12-volt cable so that original cable placement can be duplicated properly. It may be helpful to mark the clip locations and cable routing with a paint pen prior to removal.



**Figure 28 – 12-Volt Cable Clips**

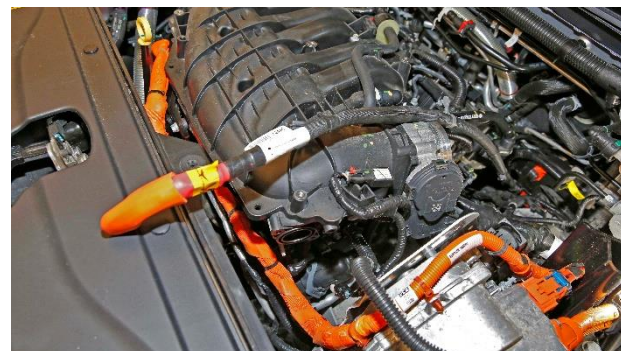
10. Release the clips (1) that secure the 12-volt cable (Figure 28).

11. Release the clips (1) that secure the 12-volt cable to the high voltage cable carrier and extend the harness to prepare for removal from below (Figure 29).



**Figure 29 – 12-Volt Cable Clips**

12. Thread the 12-volt cable clear of all components and lay out straight so that it can be pulled through the engine compartment from underneath the vehicle (Figure 30).



**Figure 30 – 12-Volt Cable**

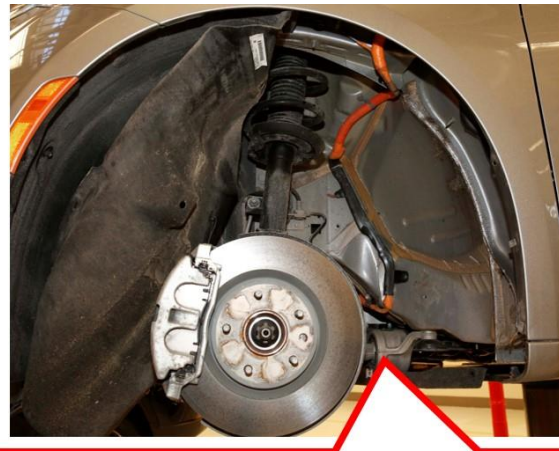
**Service Procedure [Continued]**

13. Raise and support the vehicle for tire and wheel removal.
14. Remove the left front tire and wheel.
15. Remove the fasteners securing the rear half of the left front splash shield. Then position the rear half of the splash shield out of the way for cable access (Figure 31).

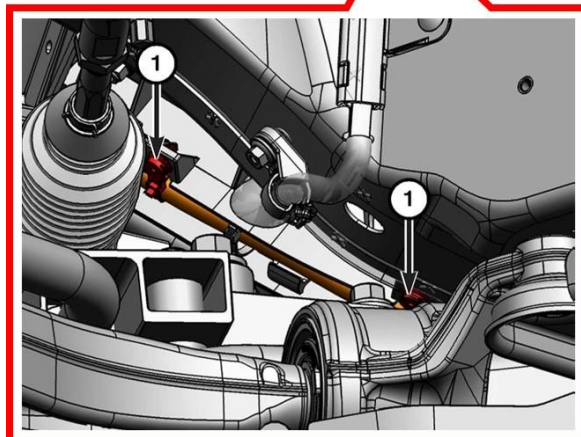


**Figure 31 – Wheel House Splash Shield**

16. Working through the wheel opening, release the clips (1) securing the 12-volt cable to the high voltage cable carrier (Figure 32).



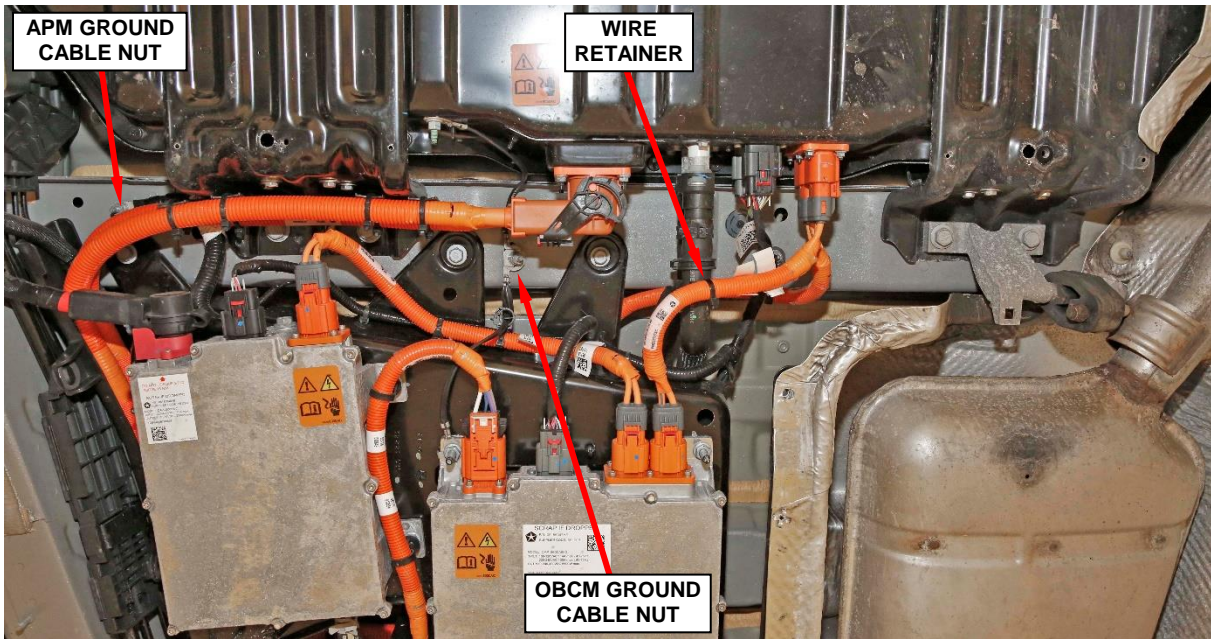
17. Cut any cable ties retaining the 12-volt cable to the high voltage cable carrier.



**Figure 32 – 12-Volt Cable**

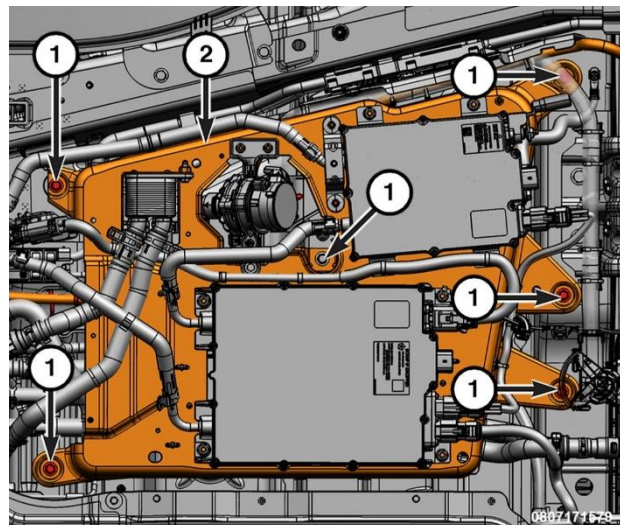
**Service Procedure [Continued]**

18. Release the wire retainer from the coolant hose (Figure 33).
  
19. Remove the On-Board Charging Module (OBCM) chassis ground cable nut and Accessory Power Module (APM) chassis ground cable nut (Figure 33).



**Figure 33 – Wire Retainer and Ground Cable nuts**

20. Position a suitable stand to support the battery charger bracket (2) and remove the fasteners (1) (Figure 34).



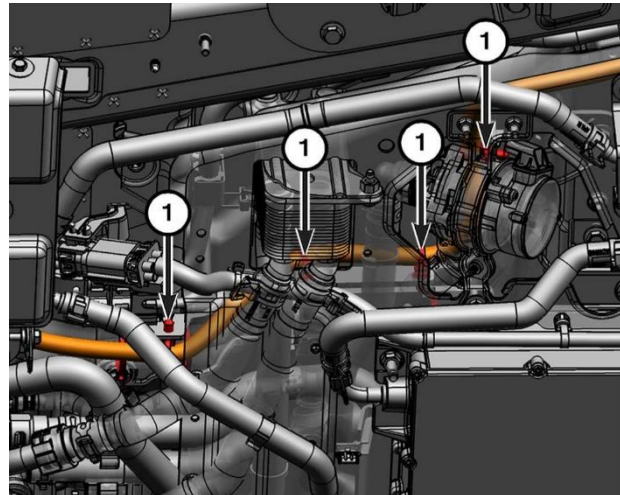
**Figure 34 – Battery Charger Bracket**

**Service Procedure [Continued]**

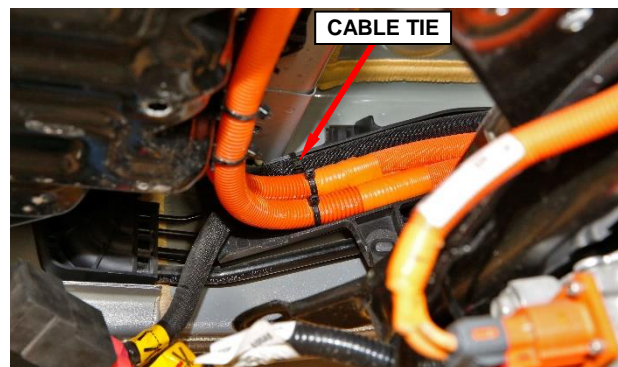
21. Carefully lower the battery charger bracket to release the remaining 12-volt Cable clips (1) (Figure 35).
22. Cut the cable tie retaining the 12-volt cable to the cable carrier. It is not necessary to replace this cable tie during reassembly (Figure 36).
23. Release the protective cover and remove the fasteners that secures the 12-volt cable terminal to the Accessory Power Module (APM) (Figure 37).

**NOTE: Pay very close attention to original cable clip locations and cable routing during the removal of the 12-volt cable so that original cable placement can be duplicated properly. It may be helpful to mark the clip locations and cable routing with a paint pen prior to removal.**

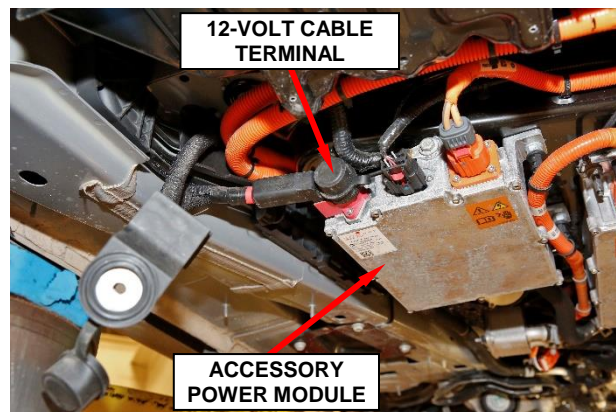
24. Carefully remove the 12-volt cable from the vehicle. Render the cable unusable and discard.
25. Remove previously cut tie straps from their locations to allow installation of new 12-volt cable.



**Figure 35 – 12-Volt Cable**



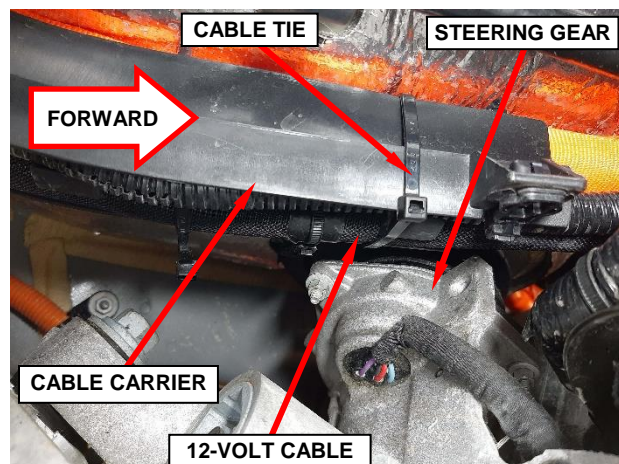
**Figure 36 – 12-Volt Cable**



**Figure 37 – 12-Volt Cable**

**Service Procedure [Continued]**

26. Carefully route the **NEW** 12-volt cable through the battery charger bracket.
27. Secure the clips (1) making sure that they are properly positioned (Figure 35).
28. Connect the 12-volt cable to the APM then tighten the captive nut to 23 N·m (17 ft. lbs.) (Figure 37).
29. Position the battery charger bracket and tighten the fasteners to 25 N·m (18.5 ft. lbs.) (Figure 34).
30. Install the OBCM and APM chassis ground cable nuts and tighten to 9 N·m (80 in. lbs.) (Figure 33).
31. Attach the wire retainer to the coolant hose (Figure 33).
32. Route the remaining section of the 12-volt cable up the bulkhead into the engine compartment.
33. Working through the wheel opening, attach the clips (1) securing the 12-volt cable to the high voltage cable carrier (Figure 32).
34. Using the cable tie provided in the campaign kit, secure the 12-volt cable to the high voltage cable carrier to prevent cable contact to the steering gear (Figure 38).

**Figure 38 – Cable Tie at Steering Gear**

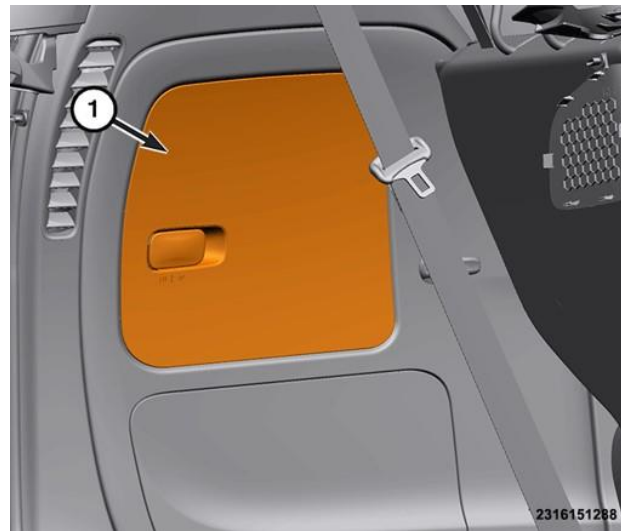
**Service Procedure [Continued]**

35. Position the rear half of the splash shield into proper location and install the fasteners securing the rear half of the left front splash shield (Figure 31).
36. Install the left front tire and wheel. Tighten the wheel lugs to 135 N·m (100 ft. lbs.).
37. Thread the 12-volt cable into the engine compartment (Figure 30).
38. Position the 12-volt cable to the bulk head cable carrier then secure the clips (1) (Figure 29).
39. Position the 12-volt cable next to the PDC then secure the clips (1) (Figure 28).
40. Position the resonator, air cleaner housing, and air inlet duct as an assembly into the engine compartment (Figure 27).
41. Engage the air inlet duct locating pins to the rubber mount sockets (Figure 27).
42. Engage the clean air housing locating pins to the rubber mount sockets (Figure 27).
43. Install the resonator to the throttle body and engage the locating pins to the rubber mount sockets (Figure 27).
44. Connect the fresh air makeup hose to the air cleaner housing (Figure 27).
45. Connect the wire harness connector to the IAT sensor (Figure 27).

**Service Procedure [Continued]**

- 46. Install the fastener securing the resonator (Figure 27).
- 47. Install the engine cover (Figure 26).

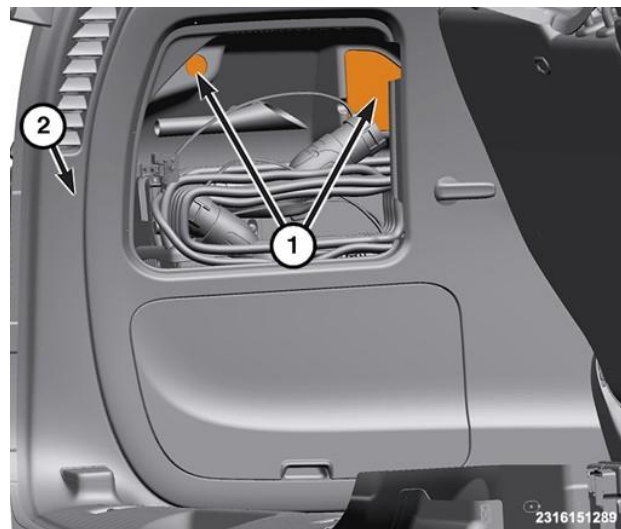
- 48. Open the access door (1) from the quarter trim panel (Figure 39).



**Figure 39 – Quarter Panel Insert**

**NOTE: The access door is not shown for visual clarity.**

- 49. Remove the fastener covers (1) (Figure 40).

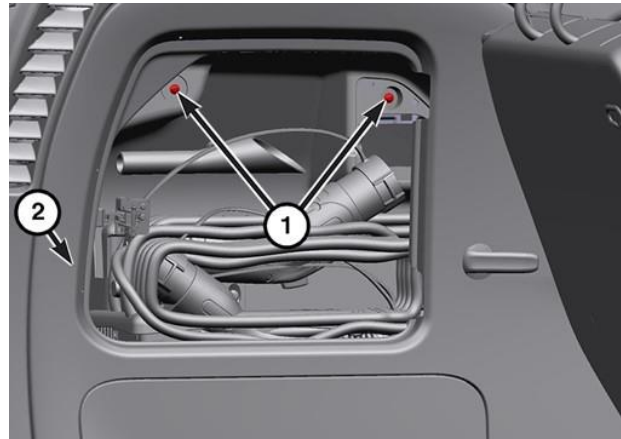


**Figure 40 – Quarter Panel Insert**



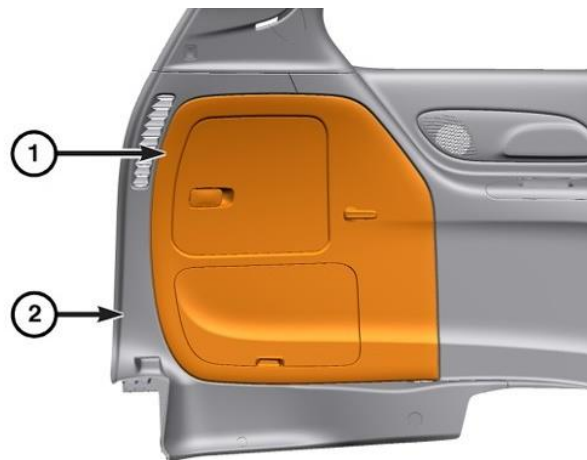
**Service Procedure [Continued]**

50. Remove the fasteners (1) from the quarter panel trim (2) (Figure 41).



**Figure 41 – Quarter Panel Insert**

51. Using a trim stick or equivalent, release the quarter panel trim insert (1) from the quarter panel trim panel (2) (Figure 42).



**Figure 42 – Quarter Panel Insert**

52. Remove the left side second row seat for improved access to rear quarter trim and 12-volt cable (Figure 43).

**NOTE: Ensure the left third row seat is in the stowed position as previously directed.**



**Figure 43 – Second Row Seat Left Side**

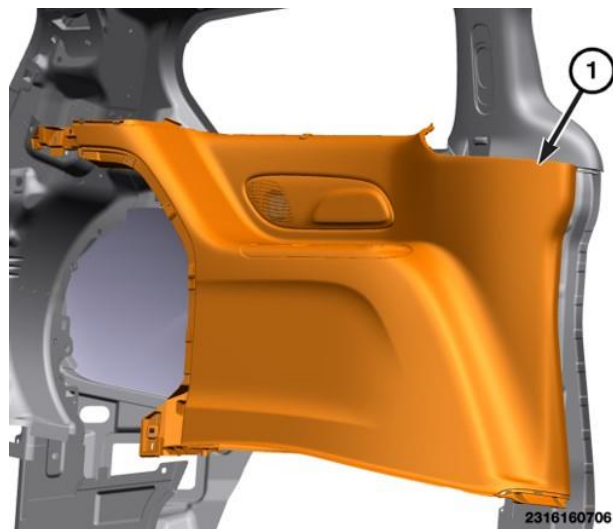
**Service Procedure [Continued]**

53. Release the D-pillar trim panel retaining clips and disconnect any electrical connectors then position aside. It is not necessary to release the D-pillar trim panel from the seat belt or remove it from the vehicle (Figure 44).



**Figure 44 – D-Pillar Trim Panel**

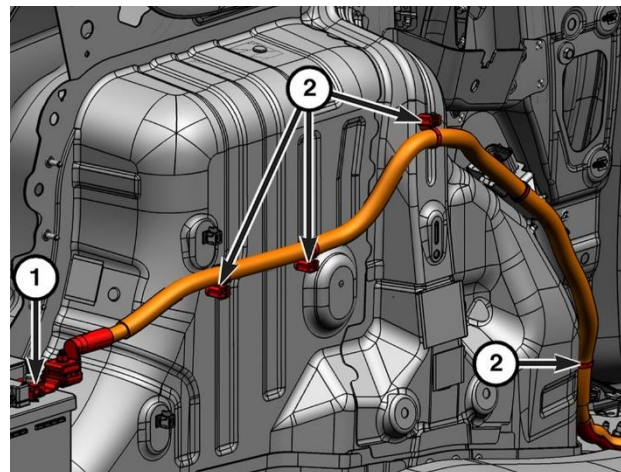
54. Using a trim stick or equivalent, starting at the top and release the fasteners at the front edge the quarter trim panel (1) carefully release the top of the quarter trim panel from the C-pillar trim panel (Figure 45).



**Figure 45 – Quarter Trim Panel**

**NOTE: It is not necessary to completely remove the quarter trim from the vehicle. Only necessary to tilt it to gain access to the 12-volt cable.**

55. Disconnect the 12-volt cable battery positive clamp (1) from the battery (Figure 46).



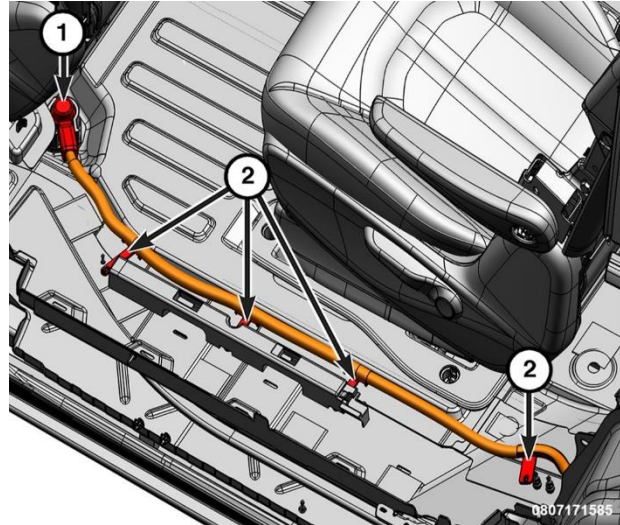
**Figure 46 – 12-Volt Cable**

56. Remove the clips (2) securing the 12-volt cable to the body (Figure 46).

**Service Procedure [Continued]**

57. Pull back the floor covering to gain access to the 12-volt cable, remove the clips (2) and remove the cable from the vehicle. Render the cable unusable and discard (Figure 47).

58. Position the **NEW** 12-volt cable into the vehicle, secure the clips (2) (Figure 47).



**Figure 47 – Quarter Trim Panel**

59. Position the 12-volt cable and secure the clips (2) (Figure 46).

60. Connect the 12-volt cable battery positive terminal end (1) and tighten to 6 N·m (53 in. lbs.) (Figure 46).

61. Connect any electrical connectors to the quarter trim panel (1) then position the quarter trim panel in place. Carefully locate the clips, then hand tap the quarter trim panel to engage the retaining clips (Figure 45).

62. Connect any electrical connectors to the D-pillar trim panel then locate the clips and install the D-pillar trim panel tapping the quarter trim panel to engage the retaining clips (Figure 44).

63. Install the left side second row seat.

**Service Procedure [Continued]**

64. Install the quarter panel trim insert (1) into the quarter panel trim (2) making sure the retainer clips are fully seated (Figure 42).
  
65. Open the access door (1) on the quarter trim panel (Figure 39).
  
66. Install the fasteners (1) for the quarter panel trim (2) and tighten them securely (Figure 41).
  
67. Install the fastener covers (1) (Figure 40).
  
68. Close the access door (1) on the quarter trim panel (Figure 39).
  
69. Proceed to **Section D. 12-Volt Isolator Gasket Installation.**

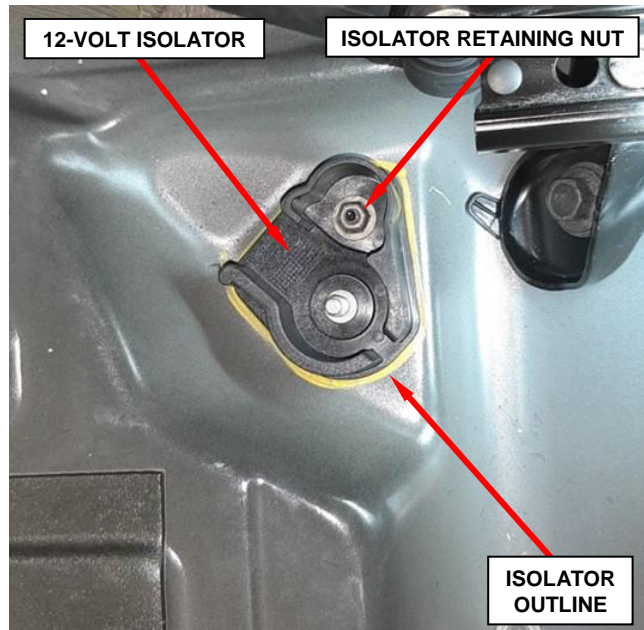
**Service Procedure [Continued]**

**D. 12-Volt Isolator Gasket Installation**

1. Draw an easily visible outline around the 12-volt isolator to be used as a location reference during reassembly (Figure 48).

**NOTE: It is recommended to use an indelible marking pen that is not easily washed away.**

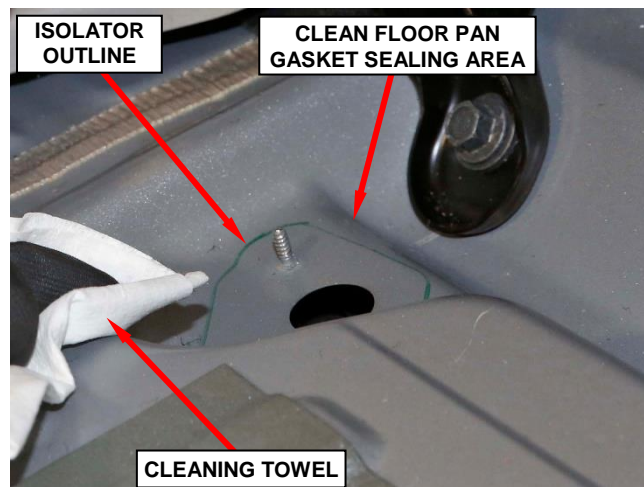
2. Remove the 12-volt isolator retaining nut then remove the isolator (Figure 48).



**Figure 48 – 12-Volt Isolator**

3. Using isopropyl alcohol or Mopar glass cleaner, clean the metal floor pan area within the isolator outline to ensure proper bonding of the isolator gasket (Figure 49).

**NOTE: Do NOT wash away the isolator outline while cleaning the floor pan. The outline will be needed for isolator installation.**

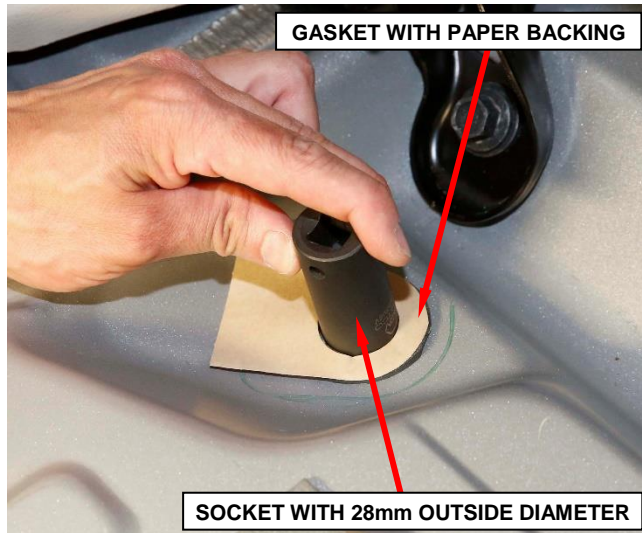


**Figure 49 – Clean Gasket Sealing Area**

**Service Procedure [Continued]**

4. Select an appropriate size socket with an outside diameter of 28mm that fits snugly into the vehicle floor pan isolator hole (Figure 50).

5. Use the socket as an alignment tool in order to center the isolator gasket (Figure 50).



**Figure 50 – 12-Volt Isolator Gasket**

6. Remove the paper or plastic film backing from one side of the isolator gasket then carefully center and apply the gasket to the floor sheet metal (Figure 50).

7. Remove the socket used for centering the gasket (Figure 51).

8. Remove the remaining side of paper or plastic film backing from the isolator gasket (Figure 51).



**Figure 51 – 12-Volt Isolator Gasket**

**Service Procedure [Continued]**

9. Were the 12-volt cables replaced on this vehicle?
- **YES:** Use the **NEW** 12-volt isolator that came with the electrical cable campaign kit. Render the **OLD** 12-volt isolator unusable and discard.
  - **NO:** Cables were not replaced. **REUSE** the existing 12-volt isolator. It will **NOT** require replacement.
10. Using isopropyl alcohol or Mopar glass cleaner, clean the floor gasket sealing surface side of the 12-volt isolator to ensure proper bonding of the isolator gasket (Figure 52).

**CAUTION:** It will not be possible to reposition the 12-volt isolator once it contacts the gasket adhesive without causing damage to the gasket. If the gasket becomes damaged, another **NEW** gasket must be obtained.

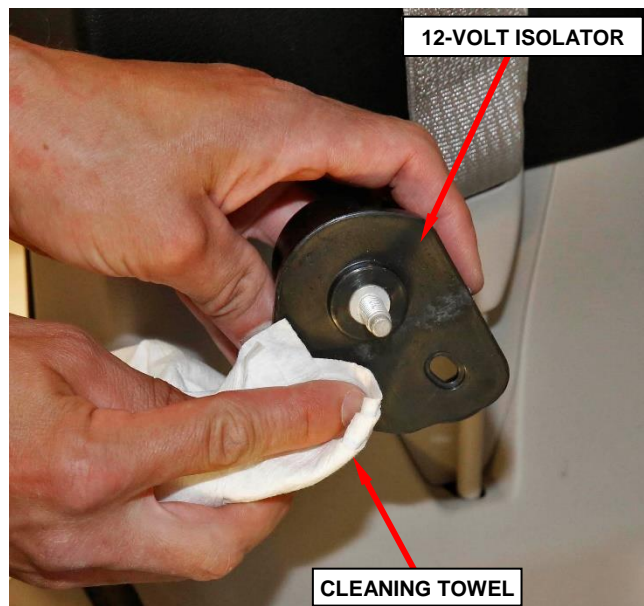
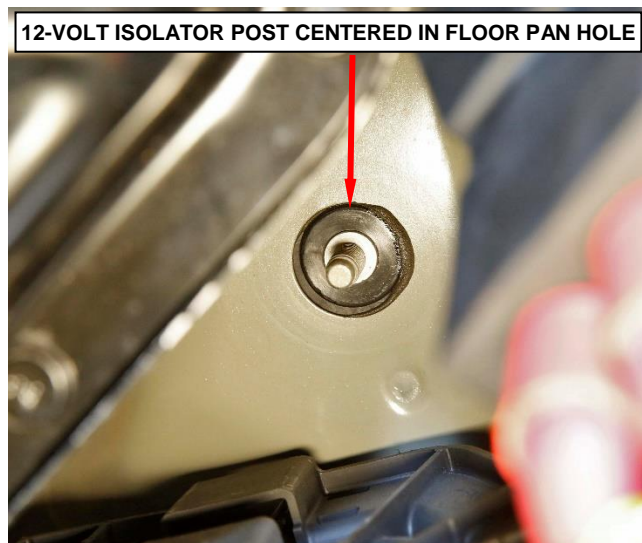


Figure 52 – Clean Gasket Sealing Area

11. Using the isolator outline drawn earlier on the floor pan, **VERY CAREFULLY** accurately align and seat in place the 12-volt isolator (Figure 48).
12. Install the retaining nut to the 12-volt isolator and tighten the nut to 5 N·m (44 in. lbs.) (Figure 48).

**Service Procedure [Continued]**

13. Install the 12-volt cable terminal to the isolator post (Figure 25).
14. Install the nut to the 12-volt isolator post terminal and tighten the nut to 23 N·m (17 ft. lbs.) (Figure 25).
15. Install the dust cover to the 12-volt cable terminal (Figure 24).
16. Install the carpet behind the front driver seat (Figure 23).
17. Install the front door sill to left side rear door opening (Figure 23).
18. Install the rear door sill to the left side rear door opening (Figure 22).
19. Install the left side rear seat track cover to the driver seat (Figure 21).
20. Raise the vehicle.
21. Inspect that the 12-volt isolator post is centered in the vehicle floor pan hole (Figure 53).



**Figure 53 – 12-Volt Isolator Post**



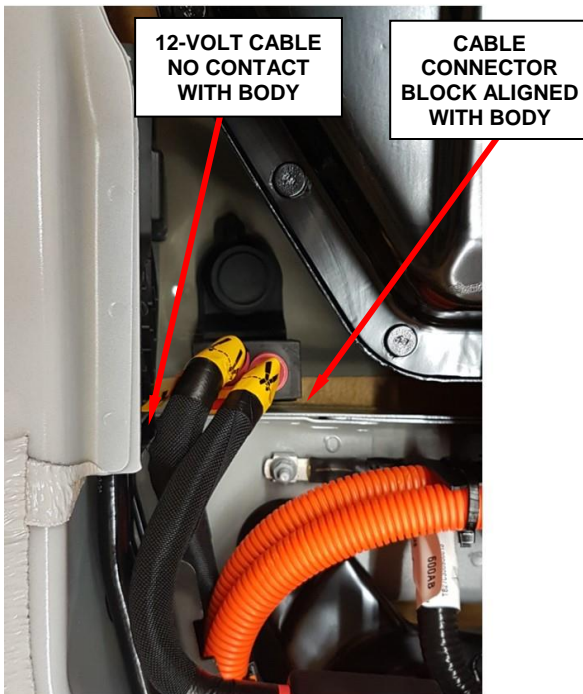
**Service Procedure [Continued]**

22. Wipe the surface of the vehicle floor around the 12-V isolator post to remove any dirt or debris before reassembling the 12-volt cable to the isolator.
23. Install the 12-volt cable terminal and nut assembly to the isolator post then tighten the nut to 23 N·m (17 ft. lbs.) (Figure 23).

**NOTE: The 12-volt cable terminal connector block may rotate during tightening. Ensure the connector block stays stationary during tightening and is properly aligned when fully tightened. Connector block should not be visibly rotated and cables should not be touching any metal surfaces after the terminal nut has been tightened to the proper torque specification (Figure 54).**

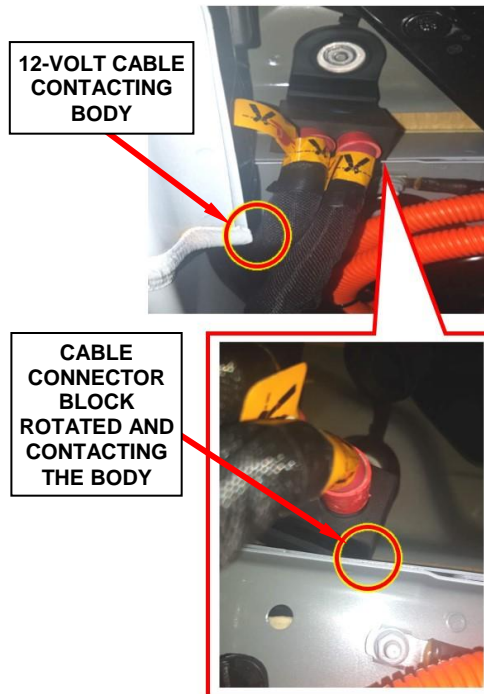
**Acceptable**

- 12-volt cable is NOT contacting the body
- Cable connector block is aligned with body NOT rotated or contacting the body



**Not Acceptable**

- 12-volt cable is contacting the body
- Cable connector block is rotated and contacting the body



**Figure 54 – Inspect 12-Volt Cable for Proper Alignment after Tightening**

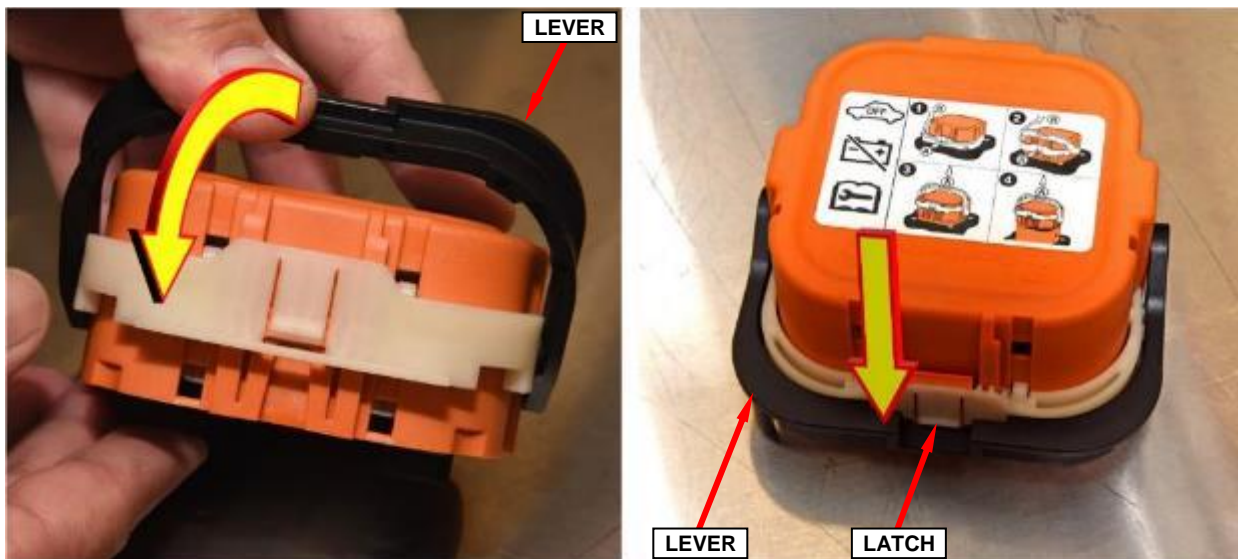
**Service Procedure [Continued]**

24. Install the dust cover to the 12-volt cable terminal (Figure 22).
25. Install the battery belly pan then install the fasteners securing the battery belly pan (Figure 21).
26. Install the charger belly pan then install the fasteners securing the charger belly pan (Figure 20).
27. Install the left side closeout panel overlapping the charger belly pan then install the closeout fasteners (Figure 19).
28. Lower the vehicle.
29. Remove the safety cover from the high-voltage battery receptacle (Figure 13).
30. Inspect the mounting interface surface of the high-voltage Manual Service Disconnect (MSD) and the receptacle wall to ensure they are clean, and that there are no surface contaminants or foreign objects within the receptacle (Figure 12).
31. Align the polarization feature of the high-voltage manual service disconnect with the receptacle on the high-voltage battery (Figure 12).
32. Push the high-voltage manual service disconnect evenly into the receptacle with the lever in the **upright 90° position**.

**NOTE: With the high-voltage manual service disconnect properly aligned with the receptacle, the lever will be released and allowed to rotate to the lock position. Do not force the lever.**

**Service Procedure [Continued]**

33. Rotate the lever downward while maintaining a slight downward force on the high-voltage manual service disconnect. The lever will engage the receptacle and draw the high-voltage manual service disconnect down onto the receptacle as the lever is rotated (Figure 55).
34. Rotate the lever downward until it is fully engaged and locked by the lever release latch. An audible “click” will be heard as the lever latches into position (Figure 55).
35. Gently pull the high-voltage manual service disconnect upward to ensure that it is fully seated in the receptacle and locked. If the manual service disconnect can be removed, repeat **steps 30 – 33**.



**Figure 55 – High-Voltage Manual Service Disconnect Latch Engagement  
(High-Voltage Manual Service Disconnect Removed from Vehicle for Visual Clarity)**

**Service Procedure [Continued]**

36. Position the high-voltage manual service disconnect access cover over the floor opening. Install the four retaining screws and tighten to 2.5 N·m (22 In. Lbs.) (Figure 9).

**NOTE: The clearance between the top of the high-voltage manual service disconnect and the bottom of the access cover is such that the access cover will not seat properly on the floor if the high-voltage service disconnect is not fully seated.**

37. Install the carpet and floor mat over the high-voltage manual service disconnect access cover (Figure 8).
38. Remove the protective cover 10084 (2035110082 equivalent) from the 12-volt positive battery cable (Figure 7).
39. Connect the positive battery cable to the 12-volt Power Distribution Center (PDC) and tighten the nut to 9 N·m (80 In. Lbs.) (Figure 6).
40. Install the 12-volt PDC cover (Figure 5).
41. Connect the battery negative cable terminal to the IBS and tighten the nut to 9 N·m (80 In. Lbs.) (Figure 4).
42. Connect the wire harness connector to the IBS (Figure 4).
43. Install the 12-volt battery access cover to the left rear quarter trim panel (Figure 3).

**Service Procedure [Continued]**

44. Install a battery charger. Verify that the charging rate provides 13.0 to 13.5 volts. Set the battery charger timer (if so equipped) to continuous charge.
45. Connect the wiTECH micro pod II to the vehicle data link connector.
46. Place the ignition in the “**RUN**” position.
47. Open the wiTECH 2.0 website.
48. Enter your “**User id**” and “**Password**” and your “**Dealer Code**”, then select “**Sign In**” at the bottom of the screen. Click “**Accept**”.
49. From the “**Vehicle Selection**” screen, select the appropriate vehicle.
50. From the “**Action Items**” screen, select the “**Topology**” tab.
51. Click “**View DTCs**”, select “**Clear All DTCs**”, click “**Continue**” and then click “**Close**”.
52. Place the ignition in the “**OFF**” position and then remove the wiTECH micro pod II device from the vehicle.
53. Remove the battery charger from the vehicle.
54. Return the vehicle to the customer or vehicle inventory.

**Completion Reporting and Reimbursement**

Claims for vehicles that have been serviced must be submitted on the DealerCONNECT Claim Entry Screen located on the Service tab. Claims paid will be used by FCA to record recall service completions and provide dealer payments.

Use one of the following labor operation numbers and time allowances:

	<b>Labor Operation Number</b>	<b>Time Allowance</b>
Inspect 12-Volt Isolator Connection Install the Isolator Gasket Only.	08-W4-61-82	1.4 hours
Inspect 12-Volt Isolator Connection Replace the 12-volt Cables and 12-volt Isolator and Install the Isolator Gasket.	08-W4-61-83	3.1 hours

Unique to this recall campaign and for instances when a customer requires a loaner vehicle with 3<sup>rd</sup> row seating, the below special labor operation should be used. Normal rates, policies, and labor operations apply for all other loaner vehicles.

Loaner Vehicle – 3 <sup>rd</sup> Row Seat	95-08-46-51	■ per day
Floor Plan Reimbursement	95-95-95-97	Calculate See Below

Floor Plan Reimbursement represents the vehicle’s average daily allowance (see table below) multiplied by the number of days the vehicle was in dealer inventory and not available for sale. This reimbursement is limited to the number of days from the date of the stop sale to the date that the remedy was made available. Note: If the vehicle was received by your dealership (KZX date) AFTER the stop sale date, you will use the KZX date instead of the stop sale date. For this Recall, the stop sale was initiated on 06/16/2020 and the remedy was made available on 07/23/2020, therefore, the number of days cannot exceed 37 days.

Vehicle	Average Daily Allowance
2017 - 2020 (RU) Chrysler Pacifica PHEV	■

**NOTE: See the Warranty Administration Manual, Recall Claim Processing Section, for complete recall claim processing instructions.**

## Dealer Notification

To view this notification on DealerCONNECT, select “Global Recall System” on the Service tab, then click on the description of this notification.

## Owner Notification and Service Scheduling

All involved vehicle owners known to FCA are being notified of the service requirement by first class mail. They are requested to schedule appointments for this service with their dealers. A generic copy of the owner letter is attached.

## Vehicle Lists, Global Recall System, VIP and Dealer Follow Up

All involved vehicles have been entered into the DealerCONNECT Global Recall System (GRS) and Vehicle Information Plus (VIP) for dealer inquiry as needed.

GRS provides involved dealers with an updated VIN list of their incomplete vehicles. The owner’s name, address and phone number are listed if known. Completed vehicles are removed from GRS within several days of repair claim submission.

To use this system, click on the “**Service**” tab and then click on “**Global Recall System.**” Your dealer’s VIN list for each recall displayed can be sorted by: those vehicles that were unsold at recall launch, those with a phone number, city, zip code, or VIN sequence.

**Dealers must perform this repair on all unsold vehicles before retail delivery.** Dealers should also use the VIN list to follow up with all owners to schedule appointments for this repair.

*Recall VIN lists may contain confidential, restricted owner name and address information that was obtained from the Department of Motor Vehicles of various states. Use of this information is permitted for this recall only and is strictly prohibited from all other use.*

**Additional Information**

If you have any questions or need assistance in completing this action, please contact your Service and Parts District Manager.

Customer Services / Field Operations  
FCA US LLC



This notice applies to your vehicle,

[Model Year and Model]

VIN XXXXXXXXXXXXXXXXXXXX

W46/NHTSA 20V-334

LOGO

VEHICLE PICTURE

#### YOUR SCHEDULING OPTIONS

- 1. RECOMMENDED OPTION**  
Call your authorized Chrysler / Dodge / Jeep® / RAM Dealership
- 2. Call the FCA Recall Assistance Center at 1-800-853-1403.** An agent can confirm part availability and help schedule an appointment
- 3. Visit recalls.mopar.com, scan the QR code below, or download the Mopar Owner's Companion App.**

QR Code

Get access to recall notifications, locate your nearest dealer, and more through this website or Mopar Owner's Companion App. You will be asked to provide your Vehicle Identification Number (VIN) to protect and verify your identity. The last eight characters of your VIN are provided above.

#### DEALERSHIP INSTRUCTIONS

Please reference Safety Recall W46.

# IMPORTANT SAFETY RECALL

## 12-Volt Isolator Post Connection

Dear [Name],

This notice is sent to you in accordance with the National Traffic and Motor Vehicle Safety Act.

FCA US has decided that a defect, which relates to motor vehicle safety, exists in certain [2017-2020 Model Year (RU) Chrysler Pacifica] Plug-In Hybrid vehicles.

It is extremely important to take steps now to repair your vehicle to ensure the safety of you and your passengers.

#### WHY DOES MY VEHICLE NEED REPAIRS?

In some circumstances, the 12-volt isolator post on your vehicle <sup>[1]</sup> may experience a high resistance electrical connection due to inadvertent liquid intrusion. High resistance electrical connections can lead to prolonged heating and a potential vehicle fire with the vehicle on or off. **A vehicle fire may increase the risk of injury to occupants and persons outside of the vehicle, as well as property damage.**

**Customers are advised to exercise the following precautions until the vehicle has this repair completed:** do not park these vehicles inside of buildings or structures and avoid parking near other vehicles. In addition, keep liquids out of the backseat area, including but not limited to beverages, wet items, umbrellas, or bottled liquids that may leak.

#### HOW DO I RESOLVE THIS IMPORTANT SAFETY ISSUE?

FCA US will repair your vehicle <sup>[2]</sup> free of charge (parts and labor). To do this, your dealer will install a gasket on the 12-volt isolator post. Your dealer will also inspect the 12-volt isolator post connection joint and if necessary, replace the isolator post and 12 volt electrical cables. The estimated repair time is about 2 hours for gasket replacement and up to 4 hours if electrical cables require replacement. In addition, your dealer will require your vehicle for proper check-in, preparation, and check-out during your visit, which may require more time. Your time is important to us, so we recommend that you schedule a service appointment to minimize your inconvenience. Please bring this letter with you to your dealership.

**TO SCHEDULE YOUR FREE REPAIR,  
CALL YOUR CHRYSLER, DODGE, JEEP OR RAM DEALER TODAY**

#### WHAT IF I ALREADY PAID TO HAVE THIS REPAIR COMPLETED?

If you have already experienced this specific condition and have paid to have it repaired, you may visit [www.fcarecallreimbursement.com](http://www.fcarecallreimbursement.com) to submit your reimbursement request online. <sup>[3]</sup> Once we receive and verify the required documents, reimbursement will be sent to you within 60 days. If you have had previous repairs performed and/or already received reimbursement, you may still need to have the recall repair performed.

We apologize for any inconvenience, but are sincerely concerned about your safety. Thank you for your attention to this important matter.

Customer Assistance/Field Operations  
FCA US LLC



**Mr. Mrs. Customer**  
**1234 Main Street**  
**Hometown, MI 48371**

[1] If you no longer own this vehicle, please help us update our records. Call the FCA Recall Assistance Center at 1-800-853-1403 to update your information.

[2] If your dealer fails or is unable to remedy this defect without charge and within a reasonable time, you may submit a written complaint to the Administrator, National Highway Traffic Safety Administration, 1200 New Jersey Ave., S.E., Washington, DC 20590, or you can call the toll-free Vehicle Safety Hotline at 1-888-327-4236 (TTY 1-800-424-9153), or go to [safercar.gov](http://safercar.gov).

[3] You can also mail in your original receipts and proof of payment to the following address for reimbursement consideration: FCA Customer Assistance, P.O. Box 21-8004, Auburn Hills, MI 48321-8007, Attention: Recall Reimbursement.

Note to lessors receiving this recall notice: Federal regulation requires that you forward this recall notice to the lessee within 10 days.