

May 2020
FL847AB
NHTSA #20V-211
Transport Canada #2020-155
REVISED NOTICE

Subject: Tire Rating Labels

Models Affected: Specific Model Years 2020-2021 Freightliner 108SD, 114SD, and Coronado vehicles; Western Star 4700 and 4900 vehicles manufactured April 26, 2019 through March 9, 2020.

General Information

Daimler Trucks North America LLC (DTNA), on behalf of its Freightliner Trucks Division, and wholly owned subsidiary, Western Star Truck Sales, Inc., has decided that a non-compliance defect that relates to motor vehicle safety exists on the vehicles mentioned above.

REVISION:The pusher/tag tires will be replaced on vehicles in FL847B, not the steer tires.

On certain vehicles, the Gross Axle Weight Rating (GAWR) on the certification label lists an incorrect higher capacity of the tires, which can lead to possible overloading of the tires and increase the likelihood of a crash.

Either the certification label will be replaced with a new one indicating the correct GAWR for the tires, or new pusher/tag tires with the correct capacity for the GAWR will be installed.

IMPORTANT: Advance arrangements are required. When a customer contacts you regarding this Recall, verify what group their vehicle is in and place an order for either the certification label or tires.

There are approximately 90 vehicles involved in this campaign.

Additional Repairs

Dealers must complete all outstanding Recall and Field Service campaigns prior to the sale or delivery of a vehicle. A Dealer will be liable for any progressive damage that results from its failure to complete campaigns before sale or delivery of a vehicle.

Owners may be liable for any progressive damage that results from failure to complete campaigns within a reasonable time after receiving notification.

Work Instructions

Please refer to the attached work instructions. Prior to performing the campaign, check the vehicle for a completion sticker (Form WAR260).

Replacement Parts

Replacement labels for vehicles in FL847A are available to order on DTNAConnect. Tires for vehicles in FL847B may be ordered from local sources (or tire replacement may be sublet). See **Table 1** for part numbers and instructions below.

If our records show your dealership has ordered any vehicle(s) involved in campaign number FL847, a list of the customers and vehicles identification numbers will be available on DTNAConnect. Please refer to this list when ordering parts for this Recall.

Table 1 - Replacement Parts for FL847

Campaign Number	Part Type	Part Description	Part Number	Qty.
FL847A	OTHER	Certification Label	24-01810-001	1 ea
FL847B	OTHER	Michelin 315/80R22.5 Tires	MCHL315225XZUS2	2 ea

Table 1

Label Ordering:

- Login to DTNAConnect portal.

May 2020
FL847AB
NHTSA #20V-211
Transport Canada #2020-155
REVISED NOTICE

- Under “DTNACONNECT RESOURCES” on the left side of the homepage, expand the “Service and References” list, and click on “Request for Certification Label or OWL”. See Fig. 1. A page titled “Request for Replacement Vehicle Documentation” will open.

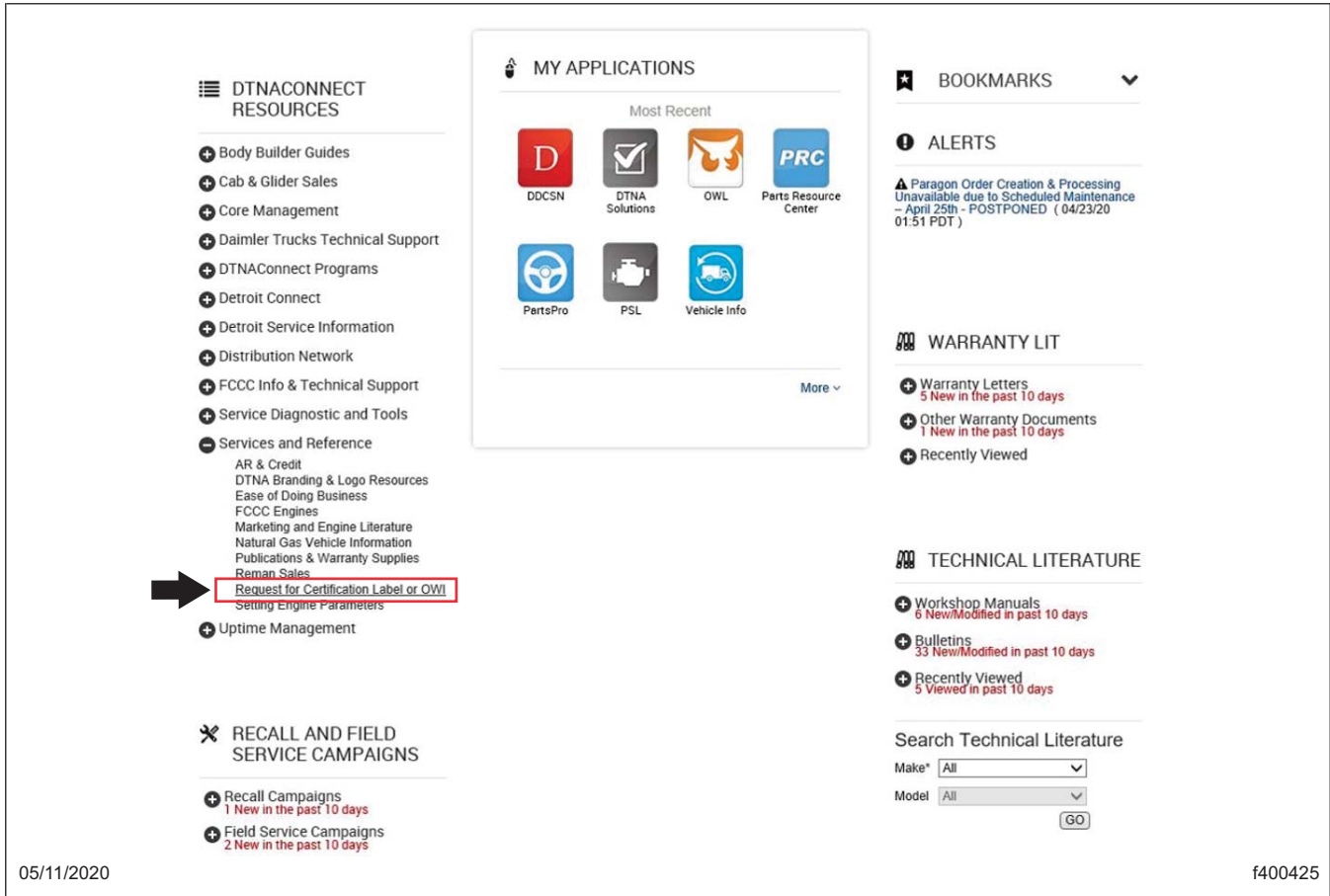

Fig. 1, DTNACONNECT Homepage

May 2020
FL847AB
NHTSA #20V-211
Transport Canada #2020-155
REVISED NOTICE

- Enter the vehicle identification number (VIN), and select “Certification Label Request”. Enter dealer code in the ‘Company Code’ box. See **Fig. 2**.

Request for Replacement Vehicle Documentation

* - indicates required field

Important: This Certification Label request only supports Freightliner, FCCC, Western Star and Sterling products. All other products need to be referred to the specific manufacturer.

To request a certification label or incomplete vehicle label please complete the below information in this form. When completed, click Review, then Submit.

All certification labels will be shipped 2nd day air from DTNA Print Center. Price of the shipping will be included in the \$50 fee.

A fee of \$20 will be applied to certification labels shipped Next Day Air.

A → Certification Label Request - \$50 fee
 Incomplete Vehicle Label - \$50 fee

B →

DEALER INFORMATION

IMPORTANT: Address provided MUST be that of the DEALERSHIP/AUTHORIZED REPAIR LOCATION, NOT that of the Customer.

C →

NVIS Requests

Canadian Dealers - Please see the Applications area of the main page to access the eNVIS application link.

US Dealers - Please contact Sandy.Hill@Daimler.com to request a NVIS form. (Note: Please contact Sandy **only for NVIS form requests** and not for other documentation needs.)

Owner's Warranty information booklets

To request an Owner's Warranty Information booklet, please submit a **Warranty Support Center** ticket. Thank you.

HOW TO OBTAIN A GVWR LABEL

DTNA does not provide GVWR certification labels for modifid vehicles. For assistance in obtaining a GVWR certification label for a vehicle that has had the GVWR changed or modified, contact the National Truck Equipment Association (NTEA) in the U.S. in Canada, contact the Canadian Transportation Equipment Association (CTEA). See information below

USA - National Truck Equipment Association (NTEA)

- Phone: (800) 441-6832
- Email: info@ntea.com

Canada - Canadian Transportation Equipment Association (CTEA)

- Phone: (519) 631-0414
- Email: transportation@ctea.on.ca

05/11/2020

f400426

A. Select "Certification Label Request".

B. Enter the VIN.

C. Enter the dealer code.

Fig. 2, Request for Replacement Vehicle Documentation

May 2020
FL847AB
NHTSA #20V-211
Transport Canada #2020-155
REVISED NOTICE

- Enter the text “For Recall FL847” in the “ADDITIONAL INFORMATION FOR CERTIFICATION LABEL REQUEST” box below. Then click on “Review”, and submit the request. See [Fig. 3](#).

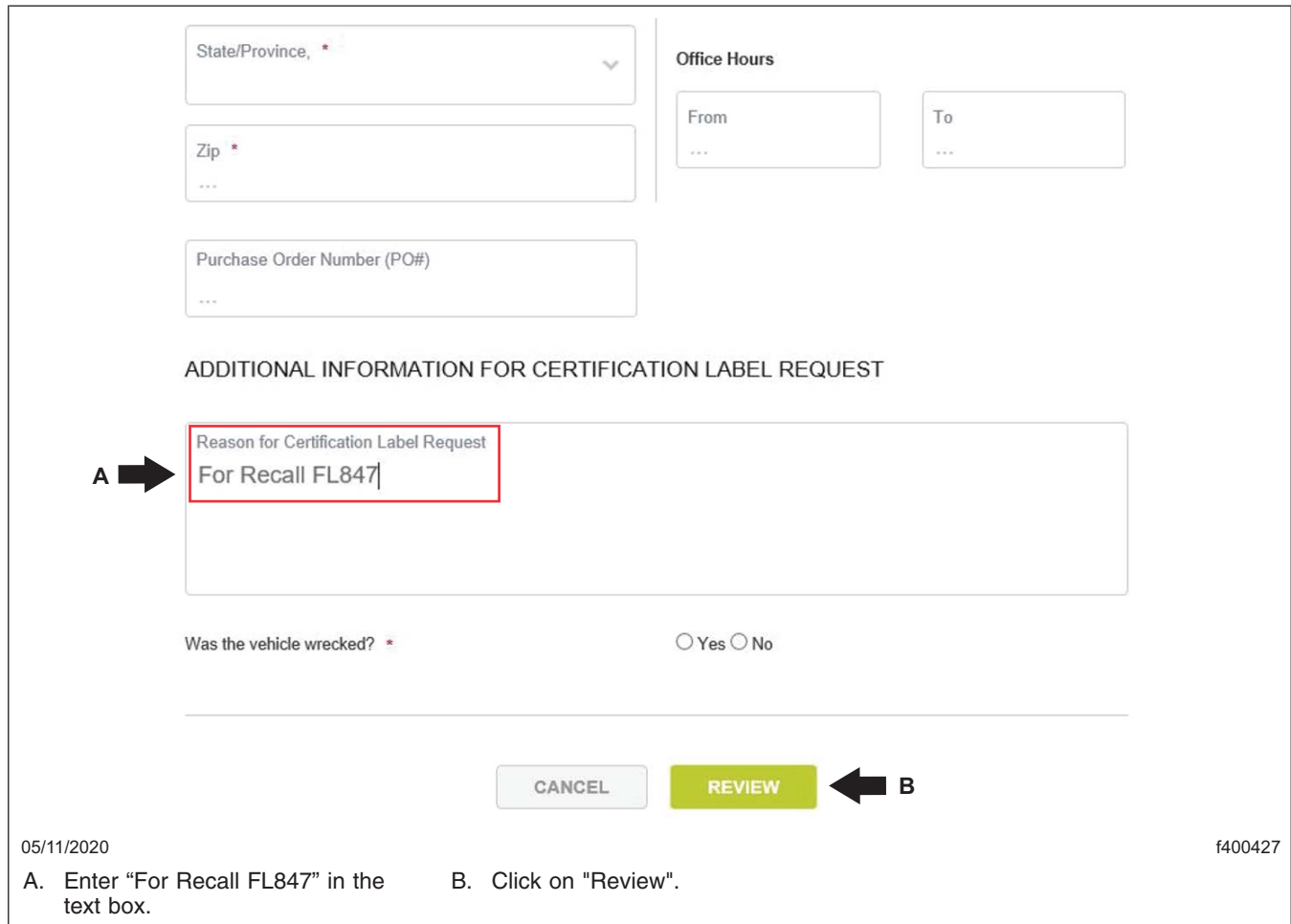

State/Province, *

Office Hours

From

To

Zip *

Purchase Order Number (PO#)

ADDITIONAL INFORMATION FOR CERTIFICATION LABEL REQUEST

Reason for Certification Label Request

For Recall FL847

Was the vehicle wrecked? * Yes No

CANCEL REVIEW

05/11/2020 f400427

A. Enter “For Recall FL847” in the text box. B. Click on “Review”.

Fig. 3, Reason for Certification Label Request

Removed Parts

U.S. and Canadian Dealers, please follow Warranty Failed Parts Tracking shipping instructions for the disposition of all removed parts. Export distributors, please destroy removed parts unless otherwise advised.

Labor Allowance

Table 3 - Labor Allowance

Campaign Number	Procedure	Time Allowed (hours)	SRT Code	Corrective Action
FL847A	Replace Certification Label	0.3	996-R092A	12-Repair Recall/Campaign
FL847B	Replace Tires	0.5	996-R092B	12-Repair Recall/Campaign

Table 2

IMPORTANT: When the Recall has been completed, locate the base completion label in the appropriate location on the vehicle, and attach the red completion sticker provided in the recall kit (Form WAR260). If the vehicle does not have a base completion label, clean a spot on the appropriate location of the vehicle and first attach the base completion label (Form WAR259). If a recall kit is not required or there is no completion sticker in the kit, write the recall number on a blank sticker and attach it to the base completion label.

May 2020
FL847AB
NHTSA #20V-211
Transport Canada #2020-155
REVISED NOTICE

Claims for Credit

You will be reimbursed for your parts, labor, and handling (landed cost for Export Distributors) by submitting your claim through the Warranty system within 30 days of completing this campaign. Please reference the following information in OWL:

- Claim type is **Recall Campaign**.
- In the Campaign field, enter the campaign number and appropriate condition code (e.g. **FL847-A** or **FL847-B**).
- In the Primary Failed Part Number field, enter **25-FL847-000**.
- In the Parts field, enter the appropriate part number(s) as shown in the Replacement Parts Table.
 - For group **FL847A** in the parts section, claim the label as part type 'OTHER'.
 - For group **FL847B** in the other charges section, claim the tires with invoice attached to claim.
- In the Labor field, first enter the appropriate SRT from the Labor Allowance Table. Administrative time will be included automatically as SRT 939-6010A for 0.3 hours.
 - If your dealership cannot perform this Recall, then arrange for a sublet with a local tire dealer. All parts and labor should be claimed as a sublet under the other charges section of the claim, with an invoice attached.
- The VMRS Component Code is **F99-999-005** and the Cause Code is **A1 - Campaign**.
- **U.S. and Canada -- Reimbursement for Prior Repairs.** When a customer asks about reimbursement, please do the following:
 - Accept the documentation of the previous repair.
 - Make a brief check of the customer's paperwork to see if the repair may be eligible for reimbursement. (See the "Copy of Owner Letter" section of this bulletin for reimbursement guidelines.)
 - Submit an OWL Recall Pre-Approval Request for a decision.
 - Include the approved amount on your claim in the Other Charges section.
 - Attach the documentation to the pre-approval request.
 - If approved, submit a based on claim for the pre-approval.
 - Reimburse the customer the appropriate amount.

IMPORTANT: OWL must be viewed prior to performing the recall to ensure the vehicle is involved and the campaign has not been previously completed. Also, check for a completion sticker prior to beginning work.

U.S. and Canadian dealers, contact the Warranty Campaigns Department via Web inquiry at DTNAConnect.com / WSC, if you have any questions or need additional information. Export distributors, submit a Web inquiry or contact your International Service Manager.

U.S. and Canadian Dealers: To return excess kit inventory related to this campaign, U.S. dealers must submit a Parts Authorization Return (PAR) to the Memphis PDC. Canadian dealers must submit a PAR to their facing PDC. All kits must be in resalable condition. PAR requests must include the original purchase invoice number. Export Distributors: Excess inventory may be returned as noted for U.S. and Canadian dealers. Export locations will pay freight to return kits. Export Distributors: Excess inventory is not returnable.

The letter notifying U.S. and Canadian vehicle owners is included for your reference.

Please note that the National Traffic and Motor Vehicle Safety Act, as amended (Title 49, United States Code, Chapter 301), requires the owner's vehicle(s) be corrected within a reasonable time after parts are available to you. The Act states that failure to repair a vehicle within 60 days after tender for repair shall be prima facie evidence of an unreasonable time. However, circumstances of a particular situation may reduce the 60 day period. Failure to repair a vehicle within a reasonable time can result in either the obligation to (a) replace the

**May 2020
FL847AB
NHTSA #20V-211
Transport Canada #2020-155
REVISED NOTICE**

vehicle with an identical or reasonably equivalent vehicle, without charge, or (b) refund the purchase price in full, less a reasonable allowance for depreciation. The Act further prohibits dealers from selling a vehicle unless all outstanding recalls are performed. Any lessor is required to send a copy of the recall notification to the lessee within 10 days. Any subsequent stage manufacturer is required to forward this notice to its distributors and retail outlets within five working days.

May 2020
FL847AB
NHTSA #20V-211
Transport Canada #2020-155
REVISED NOTICE

Copy of Notice to Owners - FL847A

Subject: Tire Rating Labels

For the Notice to U.S. Customers: This notice is sent to you in accordance with the National Traffic and Motor Vehicle Safety Act. **For the Notice to Canadian Customers:** This notice is sent to you in accordance with the requirements of the Motor Vehicle Safety Act. This is to inform you that your vehicle may be non-compliant with the requirements of the Motor Vehicle Safety Regulations and that the non-compliance could affect the safety of a person.

Daimler Trucks North America LLC (DTNA), on behalf of its Freightliner Trucks Division, and wholly owned subsidiary, Western Star Truck Sales, Inc., has decided that a non-compliance defect that relates to motor vehicle safety exists on specific Model Years 2020-2021 Freightliner 108SD, 114SD, and Coronado vehicles; Western Star 4700 and 4900 vehicles manufactured April 26, 2019, through March 9, 2020.

On certain vehicles, the Gross Axle Weight Rating (GAWR) on the certification label lists an incorrect higher capacity of the tires, which can lead to possible overloading of the tires and increase the likelihood of a crash.

The certification label will be replaced with a new one indicating the correct GAWR for the tires. Repairs will be performed by Daimler Trucks North America authorized service facilities. **IMPORTANT:** Advance arrangements are required for this Recall in order to ensure the label is available for your vehicle at the dealership.

Please contact an authorized Daimler Trucks North America dealer to arrange to have the Recall performed and to ensure that parts are available at the dealership. To locate an authorized dealer, go to www.Daimler-TrucksNorthAmerica.com. On the menu tab, select "Contact," scroll down to "Find a Dealer," and select the appropriate brand. The Recall will take approximately one half hour and will be performed at no charge to you. You may also confirm your vehicle's involvement in this recall at this URL: <https://dtna-dlrinfo.prd.freightliner.com:48518/VinLookup/vin-module/getVinLookupPage>

You may be liable for any progressive damage that results from your failure to complete the Recall within a reasonable time after receiving notification.

If you do not own the vehicle that corresponds to the identification number(s) which appears on the Recall Notification, please return the notification to the Warranty Campaigns Department with any information you can furnish that will assist us in locating the present owner. If you have leased this vehicle, Federal law requires that you forward this notice to the lessee within 10 days. If you are a subsequent stage manufacturer, Federal law requires that you forward this notice to your distributors and retail outlets within five working days. If you have paid to have this recall condition corrected prior to this notice, you may be eligible to receive reimbursement. Please see the reverse side of this notice for details.

If you have questions about this Recall, please contact the Warranty Campaigns Department at (800) 547-0712, 7:00 a.m. to 4:00 p.m. Pacific Time, Monday through Friday, e-mail address

DTNA.Warranty.Campaigns@Daimler.com. **For the Notice to U.S. Customers:** If you are not able to have the defect remedied without charge and within a reasonable time, you may wish to submit a complaint to the Administrator, National Highway Traffic Safety Administration, 1200 New Jersey Avenue, SE., Washington, DC 20590; or call the Vehicle Safety Hotline at (888) 327-4236 (TTY: 800-424-9153); or to <http://www.safercar.gov>.

For the Notice to Canadian Customers: If you wish to submit a complaint about this recall, you can contact Transport Canada road safety, 80 rue Noel, Gatineau, Quebec J8Z 0A1 or call (800) 333-0510.

We regret any inconvenience this action may cause but feel certain you understand our interest in motor vehicle safety.

WARRANTY CAMPAIGNS DEPARTMENT

Enclosure

May 2020
FL847AB
NHTSA #20V-211
Transport Canada #2020-155
REVISED NOTICE

Copy of Notice to Owners - FL847B

Subject: Tire Rating Labels

For the Notice to U.S. Customers: This notice is sent to you in accordance with the National Traffic and Motor Vehicle Safety Act. **For the Notice to Canadian Customers:** This notice is sent to you in accordance with the requirements of the Motor Vehicle Safety Act. This is to inform you that your vehicle may be non-compliant with the requirements of the Motor Vehicle Safety Regulations and that the non-compliance could affect the safety of a person.

Daimler Trucks North America LLC (DTNA), on behalf of its Freightliner Trucks Division, and wholly owned subsidiary, Western Star Truck Sales, Inc., has decided that a non-compliance defect that relates to motor vehicle safety exists on specific Model Years 2020-2021 Freightliner 108SD, 114SD, and Coronado vehicles; Western Star 4700 and 4900 vehicles manufactured April 26, 2019, through March 9, 2020.

On certain vehicles, the Gross Axle Weight Rating (GAWR) on the certification label lists an incorrect higher capacity of the tires, which can lead to possible overloading of the tires and increase the likelihood of a crash.

New tires with the correct capacity for the GAWR will be installed. Repairs will be performed by Daimler Trucks North America authorized service facilities. **IMPORTANT:** Advance arrangements are required for this Recall in order to ensure that tires are available for your vehicle at the dealership.

Please contact an authorized Daimler Trucks North America dealer to arrange to have the Recall performed and to ensure that parts are available at the dealership. To locate an authorized dealer, go to www.Daimler-TrucksNorthAmerica.com. On the menu tab, select "Contact," scroll down to "Find a Dealer," and select the appropriate brand. The Recall will take approximately one hour and will be performed at no charge to you. You may also confirm your vehicle's involvement in this recall at this URL: <https://dtna-dlrinfo.prd.freightliner.com:48518/VinLookup/vin-module/getVinLookupPage>

You may be liable for any progressive damage that results from your failure to complete the Recall within a reasonable time after receiving notification.

If you do not own the vehicle that corresponds to the identification number(s) which appears on the Recall Notification, please return the notification to the Warranty Campaigns Department with any information you can furnish that will assist us in locating the present owner. If you have leased this vehicle, Federal law requires that you forward this notice to the lessee within 10 days. If you are a subsequent stage manufacturer, Federal law requires that you forward this notice to your distributors and retail outlets within five working days. If you have paid to have this recall condition corrected prior to this notice, you may be eligible to receive reimbursement. Please see the reverse side of this notice for details.

If you have questions about this Recall, please contact the Warranty Campaigns Department at (800) 547-0712, 7:00 a.m. to 4:00 p.m. Pacific Time, Monday through Friday, e-mail address DTNA.Warranty.Campaigns@Daimler.com. **For the Notice to U.S. Customers:** If you are not able to have the defect remedied without charge and within a reasonable time, you may wish to submit a complaint to the Administrator, National Highway Traffic Safety Administration, 1200 New Jersey Avenue, SE., Washington, DC 20590; or call the Vehicle Safety Hotline at (888) 327-4236 (TTY: 800-424-9153); or to <http://www.safercar.gov>. **For the Notice to Canadian Customers:** If you wish to submit a complaint about this recall, you can contact Transport Canada road safety, 80 rue Noel, Gatineau, Quebec J8Z 0A1 or call (800) 333-0510.

We regret any inconvenience this action may cause but feel certain you understand our interest in motor vehicle safety.

WARRANTY CAMPAIGNS DEPARTMENT

Enclosure

May 2020
FL847AB
NHTSA #20V-211
Transport Canada #2020-155
REVISED NOTICE

Reimbursement to Customers for Repairs Performed Prior to Recall

If you have already **paid** to have this recall condition corrected you may be eligible to receive reimbursement.

Requests for reimbursement may include parts and labor. Reimbursement may be limited to the amount the repair would have cost if completed by an authorized Daimler Trucks North America LLC dealer. The following documentation must be presented to your dealer for consideration for reimbursement.

Please provide original or clear copies of all receipts, invoices, and repair orders that show:

- The name and address of the person who paid for the repair
- The Vehicle Identification Number (VIN) of the vehicle that was repaired
- What problem occurred, what repair was done, when the repair was done
- Who repaired the vehicle
- The total cost of the repair expense that is being claimed
- Proof of payment for the repair (such as the front and back of a cancelled check or a credit card receipt)

Reimbursement will be made by check from your Daimler Trucks North America LLC dealer.

Please speak with your Daimler Trucks North America LLC authorized dealer concerning this matter.

May 2020
FL847AB
NHTSA #20V-211
Transport Canada #2020-155
REVISED NOTICE

Work Instructions

Subject: Tire Rating Labels

Models Affected: Specific Model Years 2020-2021 Freightliner 108SD, 114SD, and Coronado vehicles; Western Star 4700 and 4900 vehicles manufactured April 26, 2019 through March 9, 2020.

REVISION:The pusher/tag tires will be replaced on vehicles in FL847B, not the steer tires.

FL847 Work Instructions			
Campaign Number	Vehicle Make and Model	Country	Page Number
FL847A	Freightliner Coronado Trucks	US	9
FL847A	Freightliner 108SD and 114SD Trucks	US	12
FL847A	Western Star Trucks 4700 and 4900 Trucks	US	13
FL847A	Western Star Trucks 4700 and 4900 Trucks	CAN	16
FL847B	ALL	US and CAN	17

Table 3, FL847 Work Instructions

Label Replacement Procedure - FL847A

Freightliner Coronado Trucks, U.S.

1. Check the base label (Form WAR259) for a completion sticker for FL847 (Form WAR260) indicating this work has been done. The base label is usually located on the passenger-side door about 12 inches (30 cm) below the door latch. If a completion sticker is present, no work is needed. If a completion sticker is not present, continue with the next step.
2. Park the vehicle on a level surface, apply the parking brakes, and shut down the engine. Chock the tires.

May 2020
 FL847AB
 NHTSA #20V-211
 Transport Canada #2020-155
REVISED NOTICE

- Open the passenger side door, and locate the component GWR label. See [Fig. 4](#). See [Fig. 5](#) for an example of a Freightliner component GWR label.

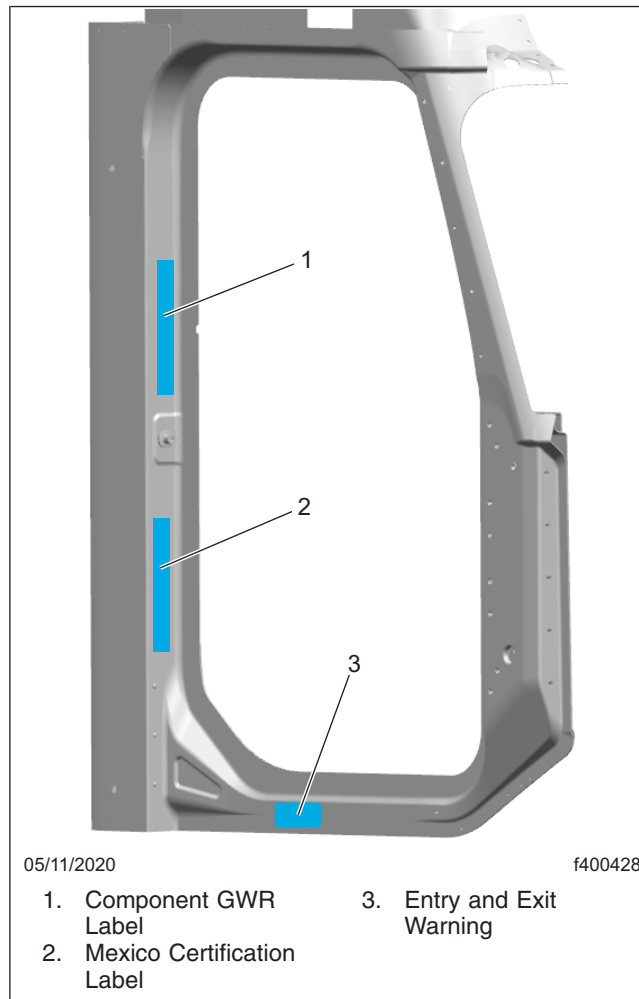

Fig. 4, Component GWR Label Location, Coronado

MAXIMUM GWR BY COMPONENT (KG/LBS)	FRONT AXLE						REAR AXLE						COMPONENT GVWR
	AXLES:	(5443) 12000	(9072) 20000	(9072) 20000	(9072) 20000	(9072) 20000	(9072) 20000	(9072) 20000	(9072) 20000	(9072) 20000	(9072) 20000	CHASSIS:	
SUSPENSION:	(5443) 12000	(9072) 20000	(9072) 20000	(9072) 20000	(9072) 20000	(9072) 20000	(9072) 20000	(9072) 20000	(9072) 20000	(9072) 20000	(9072) 20000	ENG/TRANS:	
TIRES:	(5601) 12350	(9253) 20400	(9253) 20400	(9253) 20400	(9253) 20400	(9253) 20400	(9253) 20400	(9253) 20400	(9253) 20400	(9253) 20400	(9253) 20400	5TH WHEEL:	
RIMS:	(6713) 14800	(11612) 25600	(11612) 25600	(11612) 25600	(11612) 25600	(11612) 25600	(11612) 25600	(11612) 25600	(11612) 25600	(11612) 25600	(11612) 25600	PARK BRAKE:	
HUBS/SPOKES:	(6032) 13300	(10432) 23000	(10432) 23000	(10432) 23000	(10432) 23000	(10432) 23000	(10432) 23000	(10432) 23000	(10432) 23000	(10432) 23000	(10432) 23000	AXLE:	
BRAKES:	(6032) 13300	(9072) 20000	(9072) 20000	(9072) 20000	(9072) 20000	(9072) 20000	(9072) 20000	(9072) 20000	(9072) 20000	(9072) 20000	(9072) 20000		
STEERING:	(6032) 13300											VIN: 1FUJGBDV4GLZZ9999	

Fig. 5, Freightliner Component GWR Label Example

May 2020
FL847AB
NHTSA #20V-211
Transport Canada #2020-155
REVISED NOTICE

4. Locate the new component GWR label. See Fig. 6. Make sure the VIN on the current component GWR label matches the VIN on the new component GWR label.

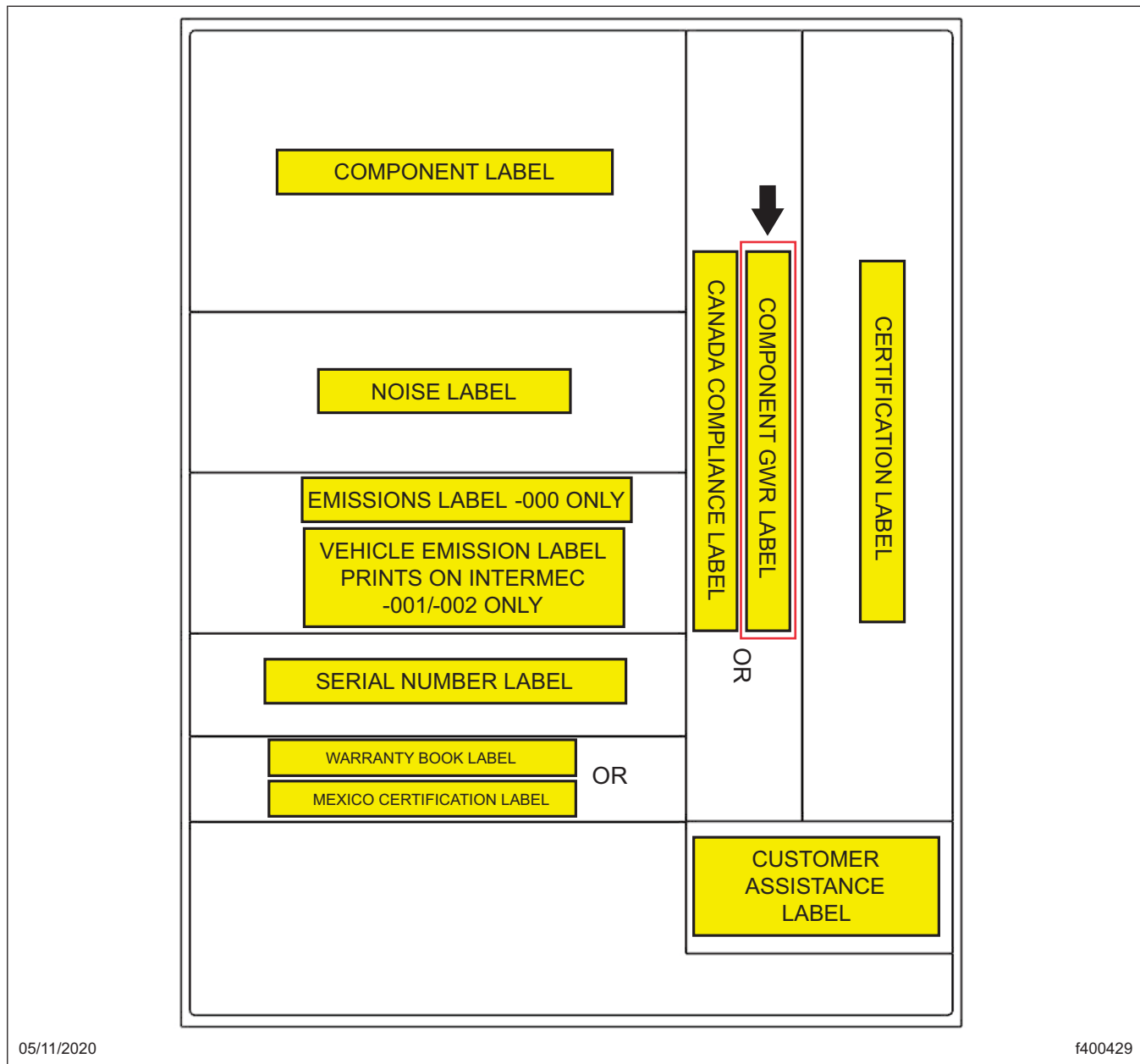

Fig. 6, Component GWR Label Location, Recall Kit, Freightliner

NOTICE

Care should be taken while removing the label. Do not damage the paint.

5. Remove the current component GWR label by peeling the clear topcoat label off, and then remove the white base label.

May 2020
FL847AB
NHTSA #20V-211
Transport Canada #2020-155
REVISED NOTICE

6. Clean the adhesive residue from the label location.
7. Ensure that the area on the door is clean and dry, and then affix the new component GWR label with the correct GAWR on it.
8. Clean a spot on the base label (Form WAR259), write recall number FL847 on a blank red completion sticker (Form WAR260), and attach it to the base label.

Freightliner 108SD and 114SD Trucks, U.S.

1. Check the base label (Form WAR259) for a completion sticker for FL847 (Form WAR260) indicating this work has been done. The base label is usually located on the passenger-side door about 12 inches (30 cm) below the door latch. If a completion sticker is present, no work is needed. If a completion sticker is not present, continue with the next step.
2. Park the vehicle on a level surface, apply the parking brakes, and shut down the engine. Chock the tires.
3. Open the passenger side door, and locate the component GWR label. See [Fig. 7](#). See [Fig. 5](#) for an example of a Freightliner component GWR label.

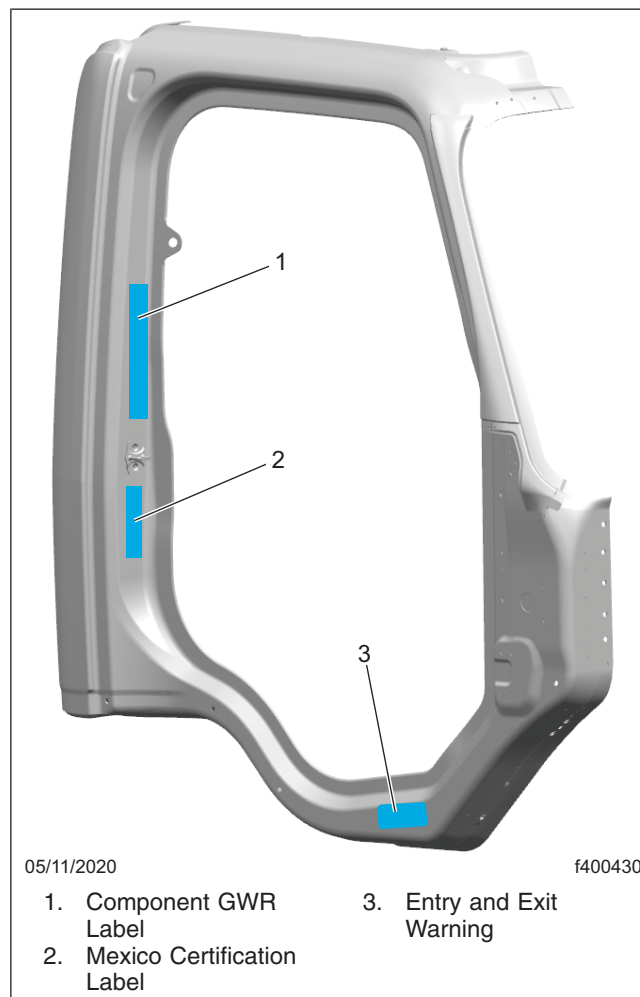

Fig. 7, Component GWR Label Location, 108SD and 114SD

May 2020
FL847AB
NHTSA #20V-211
Transport Canada #2020-155
REVISED NOTICE

4. Locate the new component GWR label. See [Fig. 6](#). Make sure the VIN on the current component GWR label matches the VIN on the new component GWR label.

NOTICE

Care should be taken while removing the label. Do not damage the paint.

5. Remove the current component GWR label by peeling the clear topcoat label off, and then remove the white base label.
6. Clean the adhesive residue from the label location.
7. Ensure that the area on the door is clean and dry, and then affix the new component GWR label with the correct GAWR on it.
8. Clean a spot on the base label (Form WAR259), write recall number FL847 on a blank red completion sticker (Form WAR260), and attach it to the base label.

Western Star Trucks, U.S.

1. Check the base label (Form WAR259) for a completion sticker for FL847 (Form WAR260) indicating this work has been done. The base label is usually located on the passenger-side door about 12 inches (30 cm) below the door latch. If a completion sticker is present, no work is needed. If a completion sticker is not present, continue with the next step.
2. Park the vehicle on a level surface, apply the parking brakes, and shut down the engine. Chock the tires.

May 2020
FL847AB
NHTSA #20V-211
Transport Canada #2020-155
REVISED NOTICE

3. Open the driver side door, and locate the component GWR label. See [Fig. 8](#). See [Fig. 5](#) for an example of a Freightliner component GWR label.

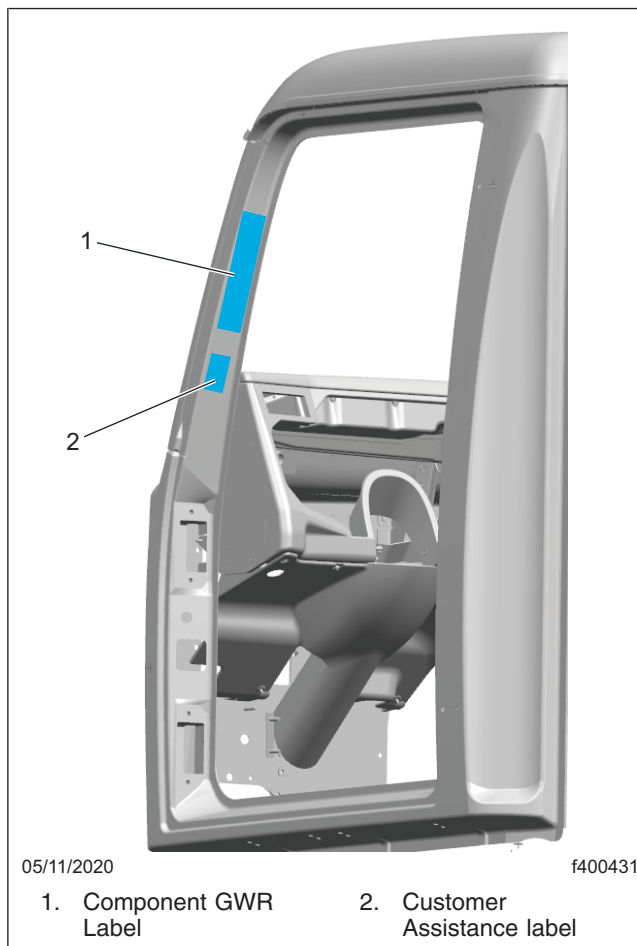

Fig. 8, Component GWR Label Location, Western Star Trucks, U.S.

May 2020
FL847AB
NHTSA #20V-211
Transport Canada #2020-155
REVISED NOTICE

4. Locate the new component GWR label. See **Fig. 9**. Make sure the VIN on the current component GWR label matches the VIN on the new component GWR label.

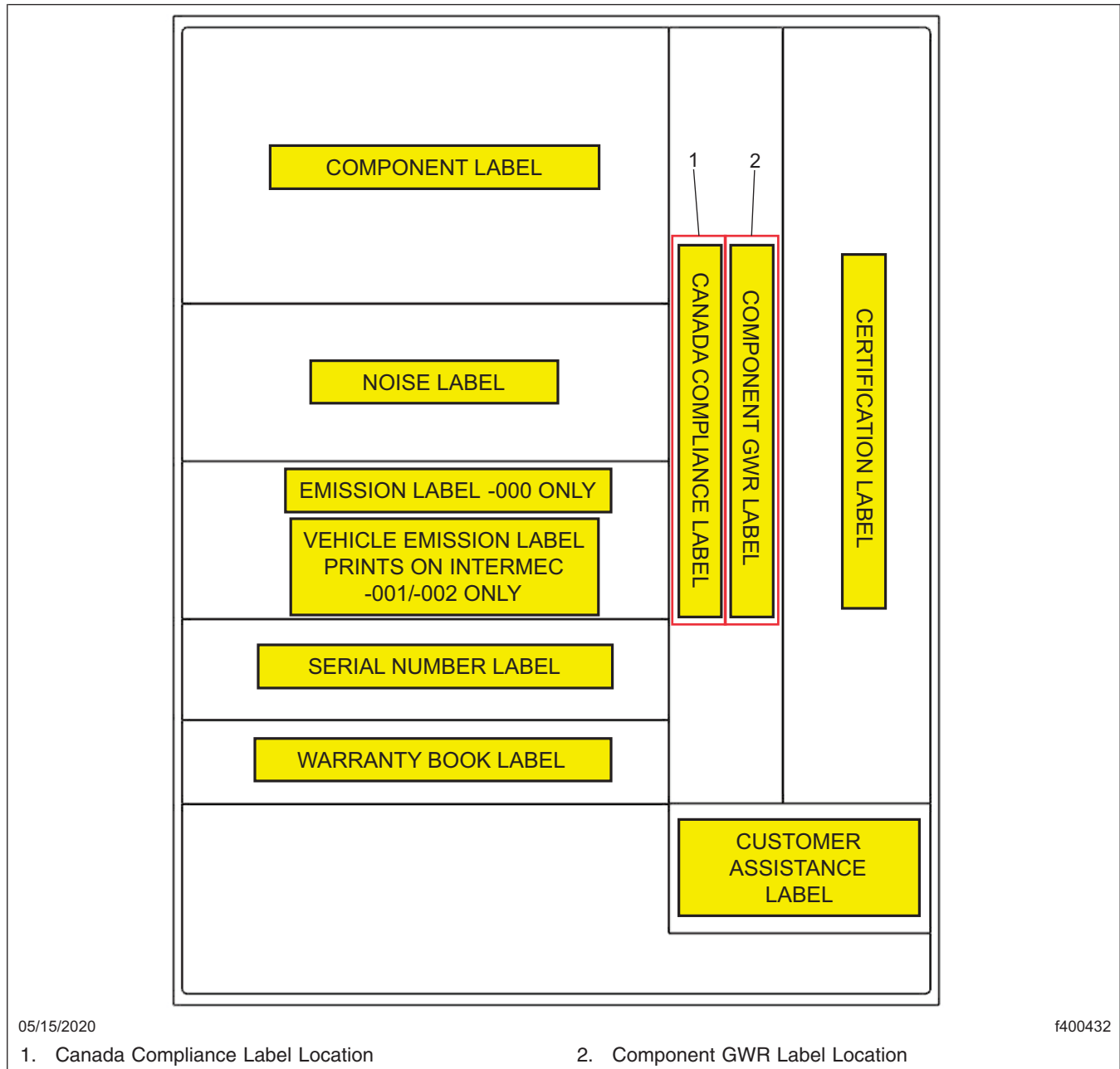

Fig. 9, Component GWR Label Location, Recall Kit, Western Star

NOTICE

Care should be taken while removing the label. Do not damage the paint.

5. Remove the current component GWR label by peeling the clear topcoat label off, and then remove the white base label.

May 2020
FL847AB
NHTSA #20V-211
Transport Canada #2020-155
REVISED NOTICE

6. Clean the adhesive residue from the label location.
7. Ensure that the area on the door is clean and dry, and then affix the new component GWR label with the correct GAWR on it.
8. Clean a spot on the base label (Form WAR259), write recall number FL847 on a blank red completion sticker (Form WAR260), and attach it to the base label.

Western Star Trucks, Canada

1. Check the base label (Form WAR259) for a completion sticker for FL847 (Form WAR260) indicating this work has been done. The base label is usually located on the passenger-side door about 12 inches (30 cm) below the door latch. If a completion sticker is present, no work is needed. If a completion sticker is not present, continue with the next step.
2. Park the vehicle on a level surface, apply the parking brakes, and shut down the engine. Chock the tires.
3. Open the driver side door, and locate the component GWR label and the Canada Compliance label. See [Fig. 8](#) and [Fig. 10](#). See [Fig. 5](#) for an example of a Freightliner component GWR label.

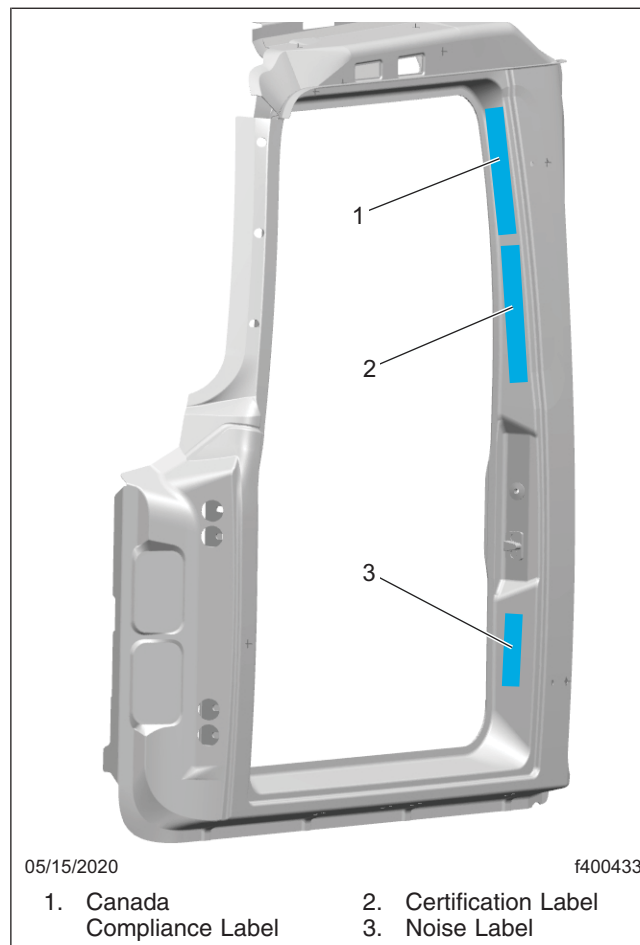

Fig. 10, Canada Compliance Label Location, Western Star Trucks, U.S.

May 2020
FL847AB
NHTSA #20V-211
Transport Canada #2020-155
REVISED NOTICE

4. Locate the new component GWR label and the new Canada Compliance label. See [Fig. 9](#). Make sure the VIN on the current component GWR label matches the VIN on the new component GWR label.

NOTICE

Care should be taken while removing the label. Do not damage the paint.

5. Remove the current component GWR label and the Canada Compliance label by peeling the clear topcoat label off, and then remove the white base label.
6. Clean the adhesive residue from the label location.
7. Ensure that the area on the door is clean and dry, and then affix the new component GWR label and the Canada Compliance label with the correct GAWR on it.
8. Clean a spot on the base label (Form WAR259), write recall number FL847 on a blank red completion sticker (Form WAR260), and attach it to the base label.

Pusher/Tag Tire Replacement - FL847B

1. Check the base label (Form WAR259) for a completion sticker for FL847 (Form WAR260) indicating this work has been done. The base label is usually located on the passenger-side door about 12 inches (30 cm) below the door latch. If a completion sticker is present, no work is needed. If a completion sticker is not present, continue with the next step.
2. Park the vehicle on a level surface, apply the parking brakes, and shut down the engine. Chock the tires.
3. Replace the existing 315/80R22.5 MCHL315225XWRKZ tires on the pusher/tag axle with Michelin 315/80R22.5 MCHL315225XZUS2 tires. Refer to **Group 40** of the applicable workshop manual for instructions.
4. Clean a spot on the base label (Form WAR259), write recall number FL847 on a blank red completion sticker (Form WAR260), and attach it to the base label.