



GROUP Safety Recall Campaign	MODEL 2013-2014MY Optima (QF) 2.4L/2.0L-T GDI
NUMBER SC187	DATE June 2020

SAFETY RECALL CAMPAIGN

**SUBJECT: LOW-PRESSURE FUEL FEED TUBE INSPECTION
AND REPAIR/REPLACEMENT (SC187)**

This bulletin provides the procedure to inspect and either repair or replace the low-pressure fuel tube assembly on some 2013-2014MY Optima (QF) vehicles produced at KMMG from November 15, 2012 through December 18, 2013. The material of the low-pressure fuel tube may deteriorate over time and develop a crack from exposure to heat generated within the engine compartment under certain circumstances. If the fuel tube develops a crack, a fuel smell and eventually a fuel leak can occur. A fuel leak increases the risk of a fire. Dealers are to inspect the low-pressure fuel tube for damage and/or leaking as outlined in this bulletin. If damage and/or leaking is found, the low-pressure fuel tube is to be replaced with a new one. If no damage or leaking is found, a heat-protective tape is to be installed at the connection between the low-pressure fuel tube and the fuel pump for added protection. Before conducting the procedure, verify that the vehicle is included in the list of affected VINs.

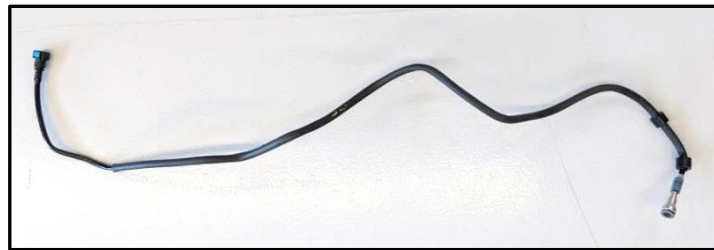

* NOTICE

There is no charge to the vehicle owner for this repair. Under applicable law, you may not sell or otherwise deliver any affected vehicle until it has been repaired pursuant to the procedures set forth in this bulletin.

* NOTICE

To assure complete customer satisfaction, always remember to refer to WebDCS Warranty Coverage (validation) Inquiry Screen (Service → Warranty Coverage → Warranty Coverage Inquiry) for a list of any additional campaigns that may need to be performed on the vehicle before returning it to the customer.

Printed TSB copy is for reference only; information may be updated at any time.
Always refer to KGIS for the latest information.

Circulate To: General Manager Service Manager Parts Manager
 Service Advisors Technicians Body Shop Manager Fleet Repair

LOW-PRESSURE FUEL FEED TUBE INSPECTION AND REPAIR/REPLACEMENT (SC187)

Flowchart:

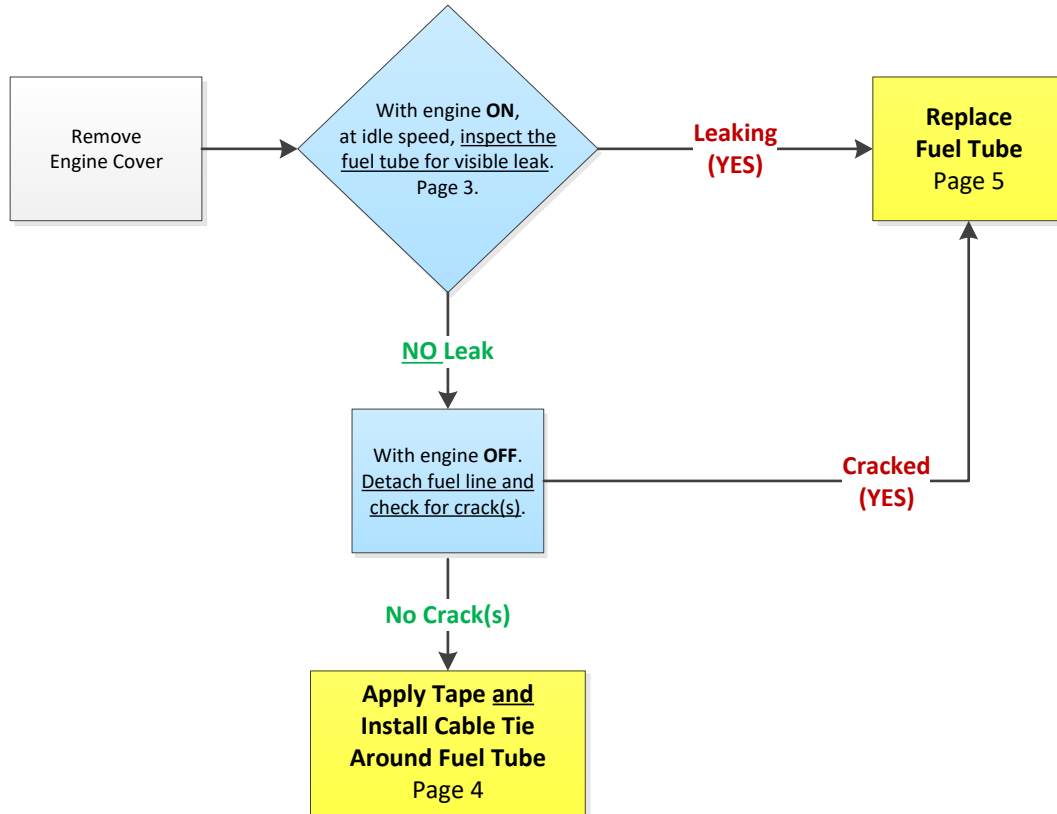

Inspection and Fuel Line Taping Procedure:

1. Open hood and remove engine cover.

Note: 2.4L GDI shown for demonstration purpose. Refer to the applicable Shop Manual on KGIS for more details and/or 2.0L-T application.



2. Locate the fuel line (A) connector and visually inspect for leak in the outlined area shown.

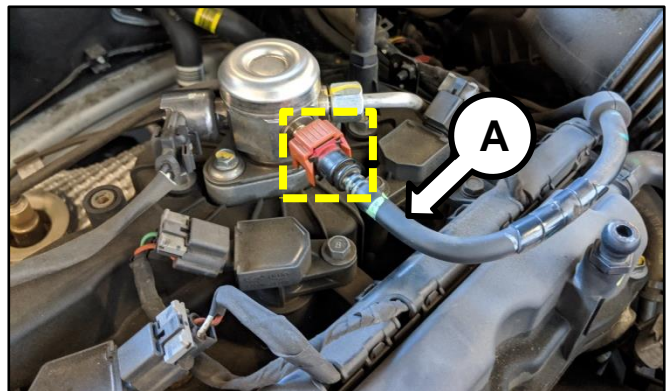

SUBJECT:

LOW-PRESSURE FUEL FEED TUBE INSPECTION AND REPAIR/REPLACEMENT (SC187)

- 3a. Start the engine and allow it to idle.
- 3b. Place the test paper under the fuel line (A) connector area shown and check for moisture on the paper, indicating presence of a leak.

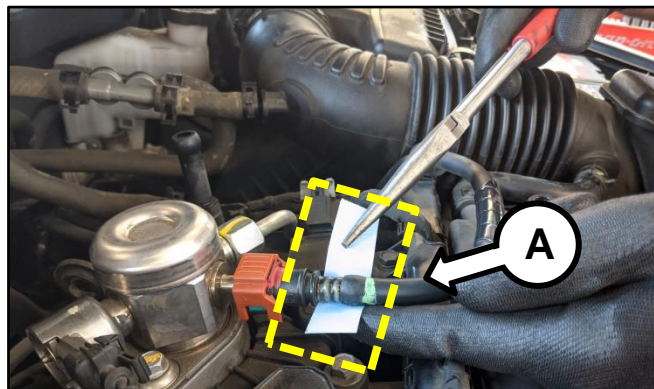

- 3c. If moisture is NOT present, turn the engine OFF and proceed to step 4 to tape and cable tie the fuel line.



- 3d. If moisture IS present, turn engine OFF and proceed to the fuel line 'Replacement Procedure' outlined on page 5.



- 4. On the fuse box located next to the air cleaner assembly, remove the 20A Fuel Pump relay (A).

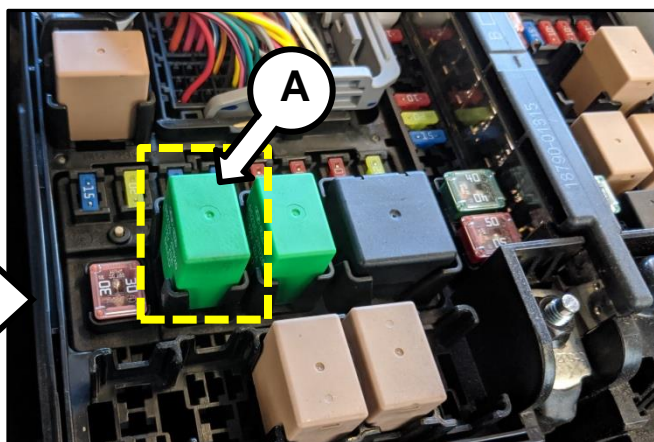
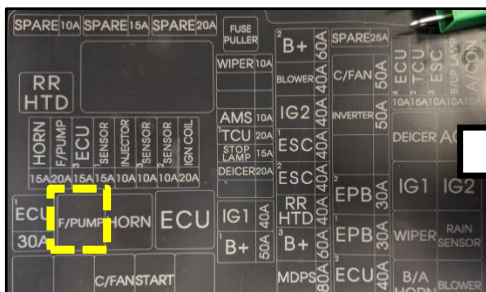

- 5a. Disconnect the high-pressure fuel pump (B) electronic connector (C).
- 5b. Attempt to start the engine to relieve fuel system pressure.

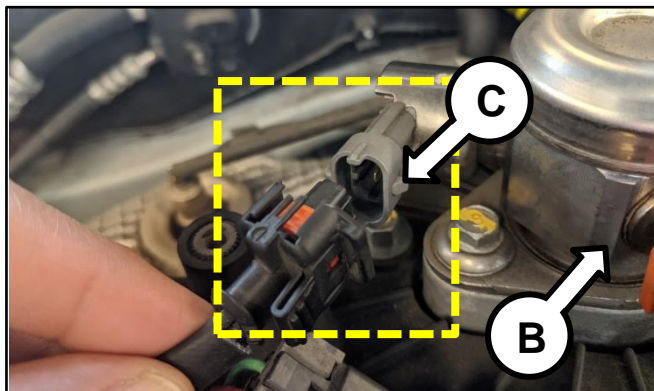

SUBJECT:

LOW-PRESSURE FUEL FEED TUBE INSPECTION AND REPAIR/REPLACEMENT (SC187)

6. Place a clean rag underneath and disconnect the fuel line (D) from the high-pressure fuel pump (B).

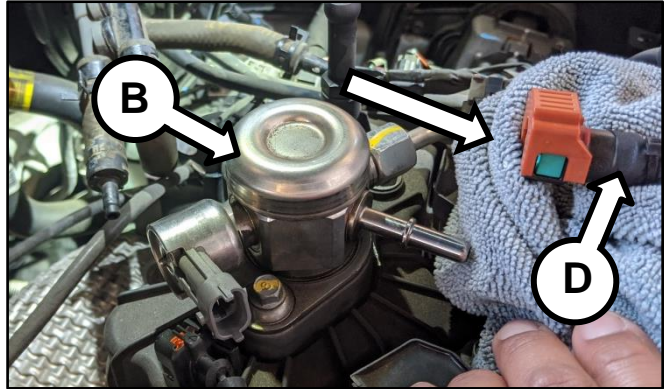

7. Using the supplied tape, tightly wrap the fuel line (A) in between the area shown below ten times (10x).

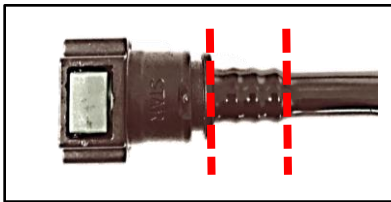

- 8a. Secure the tape to the fuel line (D) with a cable tie as shown.

- 8b. Reinstall the fuel line (D) to the high pressure pump. Ensure to insert fully to lock in place and confirm engagement.

- 8c. Re-connect the high-pressure fuel pump connector (C).

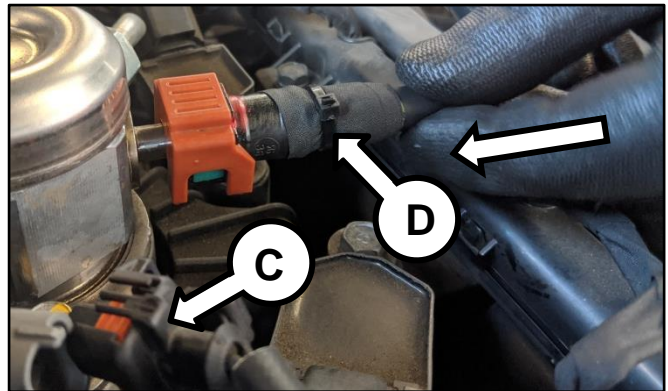

- 9a. Reinstall the fuel pump relay.

- 9b. Start the engine and allow it to idle.

- 9c. Confirm that no leak is present using test paper.

- 9d. Install the engine cover.

- 9e. Check for any DTC's stored during the procedure.



SUBJECT:

LOW-PRESSURE FUEL FEED TUBE INSPECTION AND REPAIR/REPLACEMENT (SC187)

4. Place a clean rag underneath and disconnect the fuel line (E) from the high-pressure fuel pump (C).

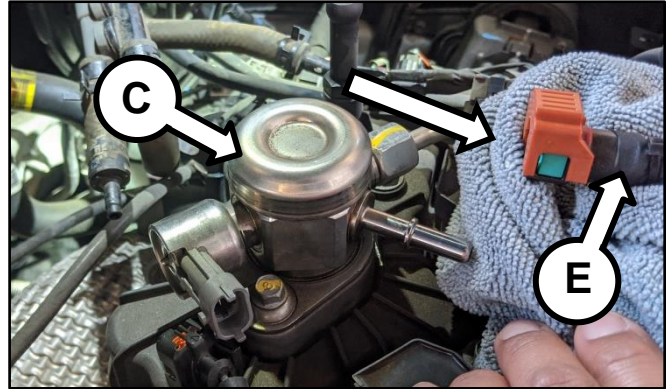

5. Remove/detach the three (3) upper fuel line (E) retaining brackets (2.4L shown).

Note: Fuel line bracket(s) routing for 2.0L-T may differ.

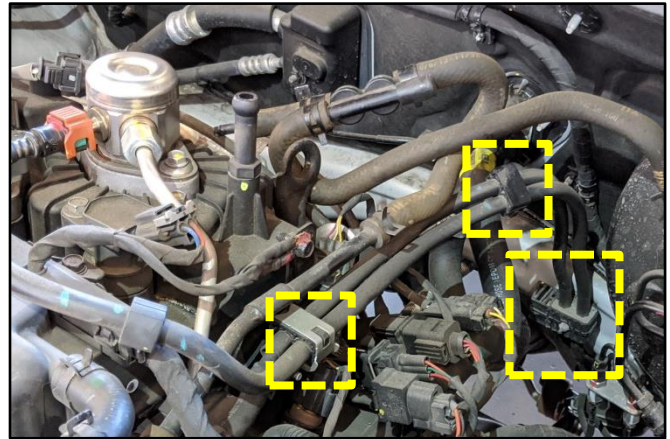

- 6a. Raise vehicle on lift.
- 6b. Remove the two (2) bottom engine covers.

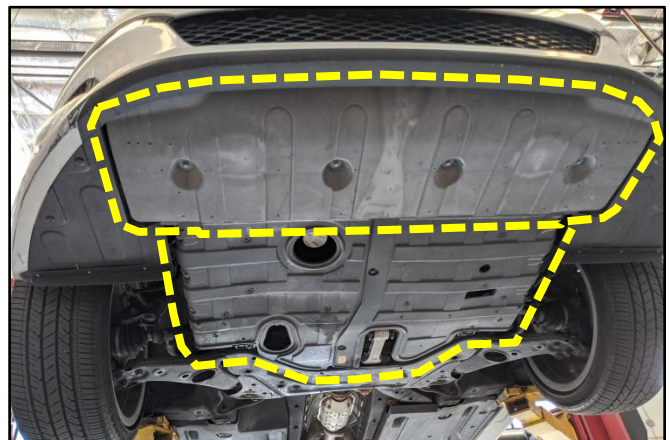

7. Remove the left (driver side) bottom cover.



SUBJECT:

LOW-PRESSURE FUEL FEED TUBE INSPECTION AND REPAIR/REPLACEMENT (SC187)

8. Detach the front bottom fuel line guard/cover and lower as shown.



- 9a. Detach the fuel line (E) from the retaining bracket.

- 9b. Press the blue tabs to disconnect/release and remove the fuel line (E).

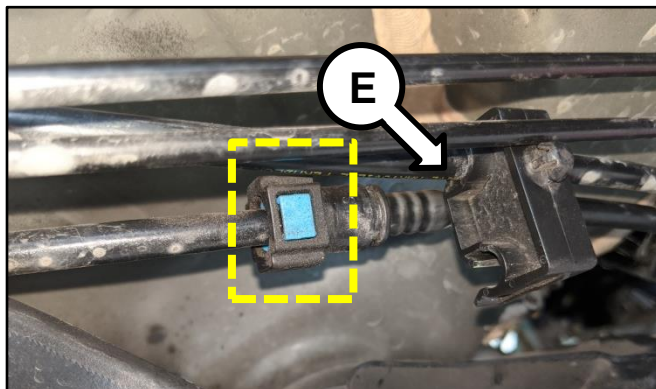

10. Install the new fuel line (F) in the reverse order of removal.

Note: Ensure fuel line is fully engaged.

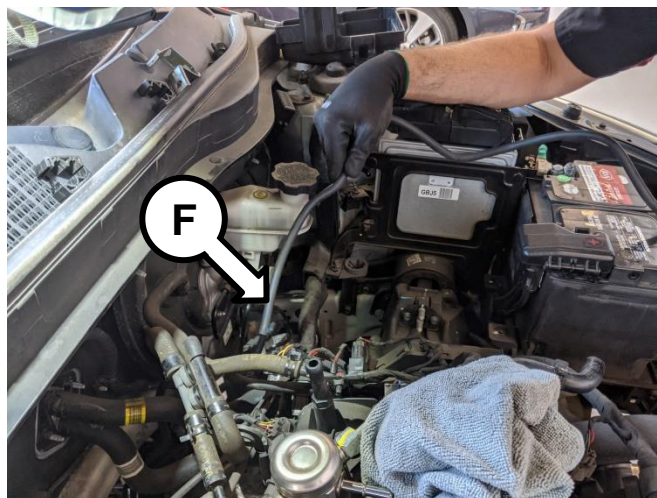

11. Reinstall the fuel pump relay.
12. Start the engine and allow it to idle.
13. Confirm that no leak is present.
14. Install the engine cover.
15. Check for any DTC's stored during the procedure.

SUBJECT:

LOW-PRESSURE FUEL FEED TUBE INSPECTION AND REPAIR/REPLACEMENT (SC187)



AFFECTED VEHICLE RANGE:

Model	Production Date Range
Optima (QF)	November 15, 2012 through December 18, 2013

REQUIRED PART:

Part Name	Part Number	Figure	Qty.
Fuel Line 2.4L	31310 3Q901QQK		1
Fuel Line 2.0L-T	31310 3Q101QQK		

REQUIRED TOOL:

Tool Name	Tool Number	Figure	Comments
Test Paper	NWPGEN180		Previously auto-shipped to dealers as part of SC172. For order or replacement, contact Snap-on Business Solutions at (888) 542-1011
PET Tape	U1915BK20C		Auto-shipped to Dealers. For order or replacement, contact Snap-on Business Solutions at (888) 542-1011
Cable Tie	CT4BK18-C (3M Hi-Temp)		Source Locally

WARRANTY INFORMATION:

N Code: N99 C Code: C99

Claim Type	ENG	Causal P/N	Qty.	Repair Description	Labor Op Code	Op Time	Replacement P/N	Qty.
R	2.4L 2.0L-T	31310 3Q900	0	(SC187) Fuel Line Inspection and Taping.	201A02I0	0.3 M/H	N/A	0
	2.4L			(SC187) Fuel Line Inspection and Replacement	201A02R0	1.6 M/H	31310 3Q901QQK	1
	2.0L-T			31310 3Q101QQK				

Note: If necessary, use sublet code 'X2' for rental expense reimbursement (up to 3 days maximum). Use sublet code 'X1' with a maximum allowed amount of \$0.20 for 3M cable tie reimbursement.

*** NOTICE**

VIN inquiry data for this repair is provided for tracking purposes only. Kia retailers should reference **SC187** when accessing the WebDCS system.