

## 1. VEHICLE INSPECTION PROCEDURE

Verify that the vehicle is within the following ranges:

2016 Model Year Mazda CX-5 vehicles, equipped with LED Daytime Running Light (DRL)

Model	Subject VIN range	Subject production date range
2016 CX-5	JM3 KE**** G0 600017 – 751326	From November 3, 2014 through December 7, 2015

The asterisk symbol “\*” can be any letter or number.

- If the vehicle is within the above ranges, proceed to **Visual and Production date Inspection and Repair Procedure**
- If the vehicle is not within the above ranges, return vehicle to the customer or inventory.

Perform a Warranty Vehicle Inquiry using your eMDCS System and inspect vehicle for Campaign Label Recall 4320A attached to the vehicle’s hood or bulkhead. Refer to eMDCS System - Warranty Vehicle Inquiry Results table below.

NOTE: Be sure to verify Recall number as the vehicle may have multiple Recall labels.

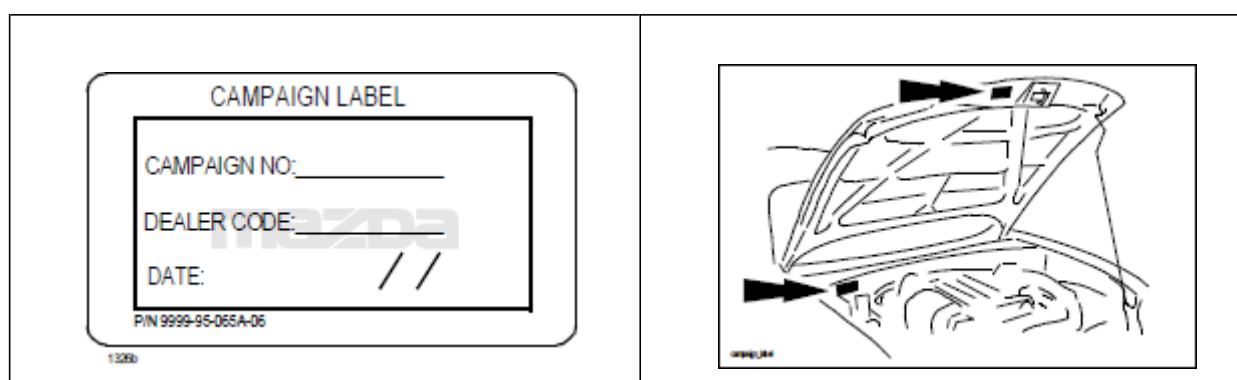



### eMDCS System - Warranty Vehicle Inquiry Results:

If eMDCS displays:	Campaign Label is:	Action to perform:
RECALL 4320A OPEN	Present	Email Dealer Recall Help or Contact Warranty Hotline at (877) 727-6626 option 3 to update vehicle history.
	Not present	Proceed to “2. REPAIR PROCEDURE”.
RECALL 4320A CLOSED	Present	Return vehicle to inventory or customer.
	Not present	Proceed to “3. CAMPAIGN LABEL INSTALLATION”.
RECALL 4320A IS NOT PRESENT	Does not apply	Recall does not apply to this vehicle. Return vehicle to inventory or customer.

## 2. REPAIR PROCEDURE

### Part /Tool information

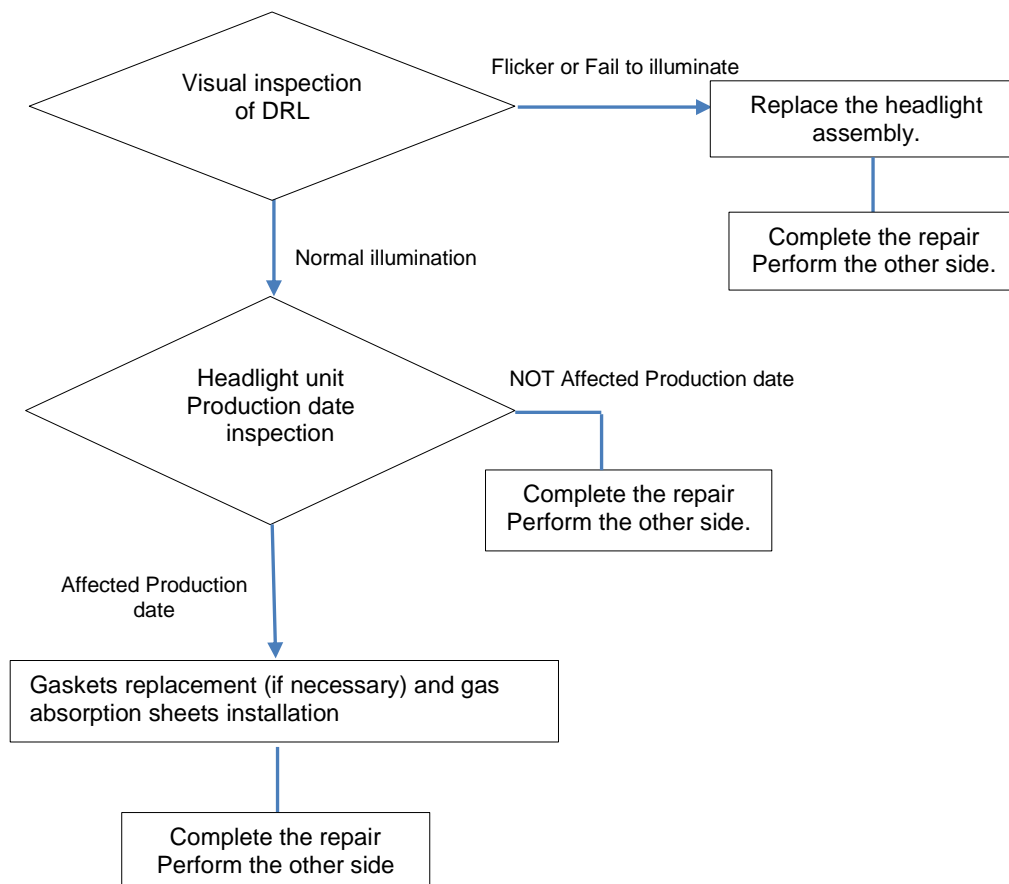

Name	Detail	Quantity	Image
GASKET KIT (PN: KAYL-51-0A2)	Black gasket	4	
	Gas absorption sheet (For absorption sulfur released from gray gasket remaining in the front combination light housing)	4	
Soft shop rags	For prevent scratches	1	N/A
Pick tool	For Gasket installation	1	N/A
Ruler or small screwdriver	For gas absorption sheet installation	1	N/A
Length of wire, string	For gasket installation and Gas absorption sheet installation	1	N/A

### Flow Chart (explains one side of headlight)

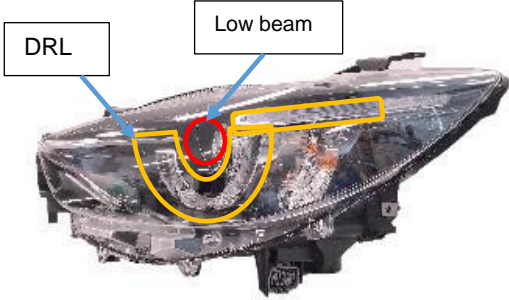

**Technical guide**

Check before repairing the affected vehicle.

AFS	Front image	Back image
Yes (Equipped)		

AFS: Adaptive Front Lighting system, which enhances the range of visibility when the headlights are turned on by pointing the optical axis of the headlights in the direction in which the vehicle is advancing according to the steering operation. The swivel actuator constantly detects the headlight swivel angle from the hall sensor built into the actuator, and inputs the swivel angle to the AFS control module via LIN communication.

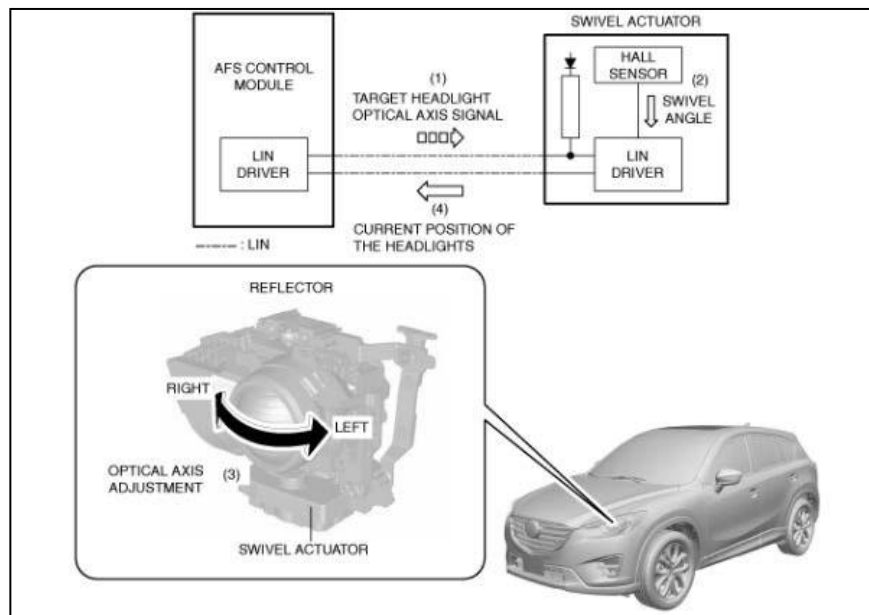

## **A. VISUAL INSPECTION**

1. Park the vehicle and turn on the engine.
2. Turn on the low beam.
3. Check the illumination of the DRL position lighting and determine if they are lighting up and not flickering. (Marked by yellow area with shown the image) For more detail, refer to inspection chart below.

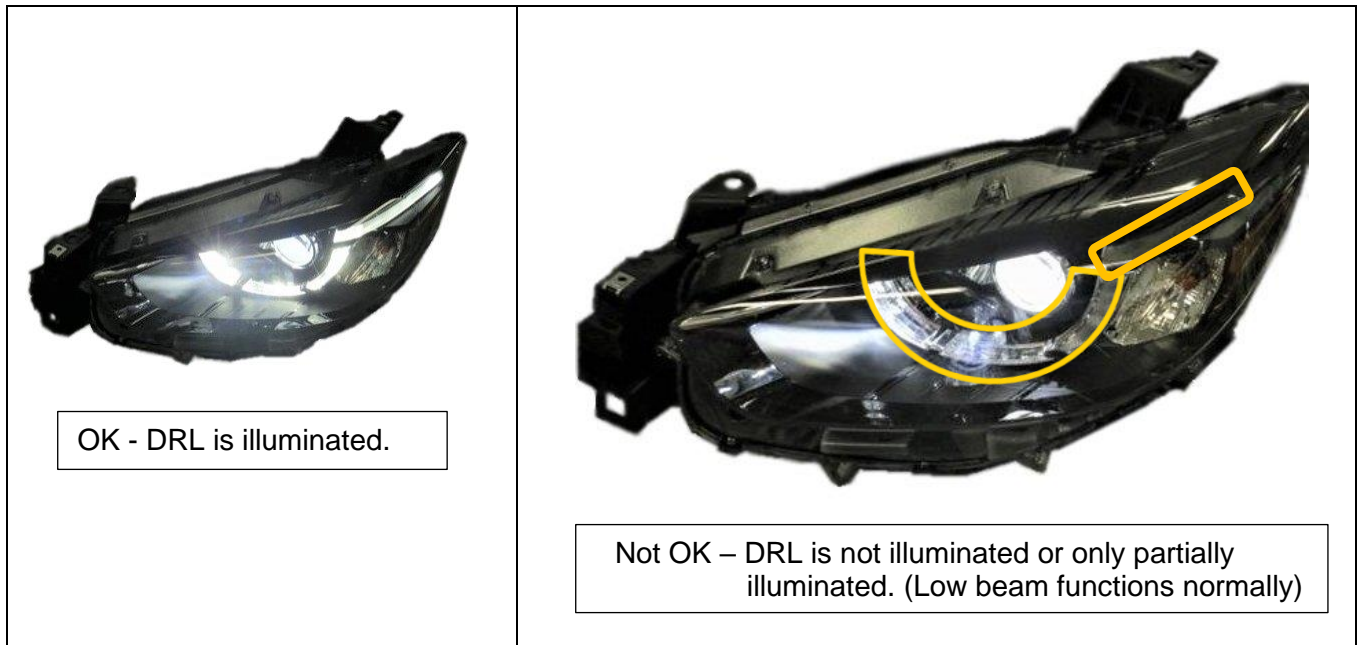

### **Judgement**

- If both Daytime Running Lamp (DRL) does not light up or the DRL is flickering, replace the both headlight assemblies and complete the repair.
- If either Daytime Running Lamp (DRL) does not light up or the DRL is flickering, replace the affected headlight assembly and go to the next step, B. (Inspect working headlight production date)
- If both Daytime Running Lamp (DRL) light up, and are not flickering, go to next step B. (Inspect working headlight production date/lot number)

**B. Headlight Production Date Inspection**

1. Open the hood.
  2. Confirm the production date of both headlights by checking the information sticker.
- Note: You can inspect the production date without removing the headlights.

(These images are for example of right side of headlight.)

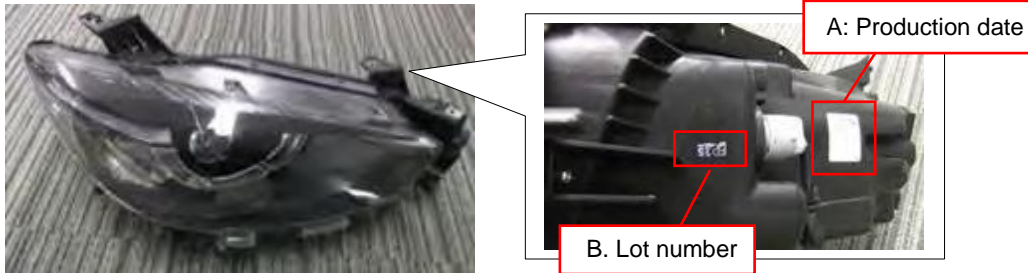

**A: Production Date Inspection**

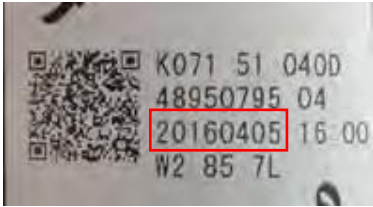
<p>Production Date Inspection</p>	<p>Check the production date printed in the white information sticker.</p> <p>Note: Production date is written around the middle of white sticker.</p>
<p>Affected production date range</p>	<p>Affected production date range:</p> <p><b>20141001 to 20151120</b></p> <p>From October 1, 2014 through November 20, 2015</p>
<p>How to read the production date</p>	<p>Example: 20160405</p>  <p>How to read the production date:</p> <div style="text-align: center;"> <p><u>2016</u>    <u>04</u>    <u>05</u></p> <p>↑            ↑            ↑</p> <div style="display: flex; justify-content: space-around;"> <div style="border: 1px solid black; padding: 2px;">Year: 2016</div> <div style="border: 1px solid black; padding: 2px;">Month: April</div> <div style="border: 1px solid black; padding: 2px;">Date: 01 to 31</div> </div> <p>Production date: April 5, 2016</p> </div>

Note: If the information sticker is missing or production date cannot be confirmed due to dirt or letters disappearing, check the lot number.

**B: Lot Number Inspection (if the production date cannot be confirmed by information sticker)**

Lot Number Inspection	Check the lot number marked in the headlight in white letters. (Refer to the photo above for the marked location.)																																																			
Affected lot number range	Affected lot number range: <b>DM01 to EN20</b> From October 1, 2014 through November 20, 2015																																																			
How to read the lot number	<p>Example: FD05</p>  <p>How to read the lot number:</p> <div style="text-align: center;"> <table border="0" style="margin: auto;"> <tr> <td style="text-align: center;">F</td> <td style="text-align: center;">D</td> <td style="text-align: center;">05</td> </tr> <tr> <td style="text-align: center;">↙</td> <td style="text-align: center;">↙</td> <td style="text-align: center;">↙</td> </tr> <tr> <td style="text-align: center;">Year: A to P</td> <td style="text-align: center;">Month: A to P</td> <td style="text-align: center;">Date: 01 to 31</td> </tr> </table> <p style="text-align: center;">Production date: April 5, 2016</p> <table border="1" style="margin: auto; border-collapse: collapse; text-align: center;"> <tr><td>Alphabet</td><td>A</td><td>B</td><td>C</td><td>D</td><td>E</td><td>F</td></tr> <tr><td>Year</td><td>2011</td><td>2012</td><td>2013</td><td>2014</td><td>2015</td><td>2016</td></tr> <tr><td>Month</td><td>Jan</td><td>Feb</td><td>Mar</td><td>Apr</td><td>May</td><td>Jun</td></tr> </table>   <table border="1" style="margin: auto; border-collapse: collapse; text-align: center;"> <tr><td>Alphabet</td><td>G</td><td>H</td><td>K</td><td>M</td><td>N</td><td>P</td></tr> <tr><td>Year</td><td>2017</td><td>2018</td><td>2019</td><td>2020</td><td>2021</td><td>2022</td></tr> <tr><td>Month</td><td>Jul</td><td>Aug</td><td>Sep</td><td>Oct</td><td>Nov</td><td>Dec</td></tr> </table> </div>	F	D	05	↙	↙	↙	Year: A to P	Month: A to P	Date: 01 to 31	Alphabet	A	B	C	D	E	F	Year	2011	2012	2013	2014	2015	2016	Month	Jan	Feb	Mar	Apr	May	Jun	Alphabet	G	H	K	M	N	P	Year	2017	2018	2019	2020	2021	2022	Month	Jul	Aug	Sep	Oct	Nov	Dec
F	D	05																																																		
↙	↙	↙																																																		
Year: A to P	Month: A to P	Date: 01 to 31																																																		
Alphabet	A	B	C	D	E	F																																														
Year	2011	2012	2013	2014	2015	2016																																														
Month	Jan	Feb	Mar	Apr	May	Jun																																														
Alphabet	G	H	K	M	N	P																																														
Year	2017	2018	2019	2020	2021	2022																																														
Month	Jul	Aug	Sep	Oct	Nov	Dec																																														

**Judgement**

- If both headlamp assemblies are not in the affected production date, the repair is complete.  
**Submit for inspection to close the recall.**
  
- If one or both of the headlamp assemblies are in the affected production date/lot number, replacement of gaskets and installation of gas absorption sheets is necessary. Go to step C.
  
- If the information sticker is missing or production date/lot number cannot be confirmed visually due to dirty/burned surface, replacement of gaskets and installation of gas absorption sheets is necessary. Go to step C.

## C. FRONT BUMPER & COMBINATION LIGHT REMOVAL/INSTALLATION

### FRONT BUMPER REMOVAL/INSTALLATION

#### Caution

- Affix the protective tape to the position (vehicle body side) shown in the figure to prevent scratches and damage.

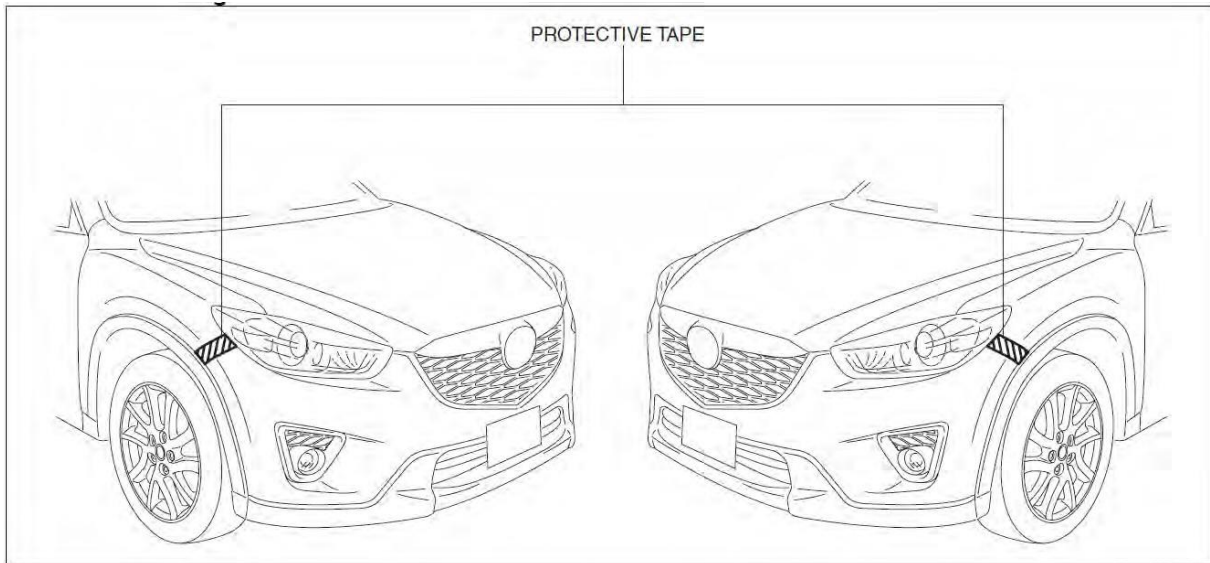

1. Disconnect the negative battery cable. (See [NEGATIVE BATTERY CABLE DISCONNECTION/CONNECTION \[SKYACTIV-G 2.5\]](#).) (See [NEGATIVE BATTERY CABLE DISCONNECTION/CONNECTION](#))
2. Remove fasteners A.

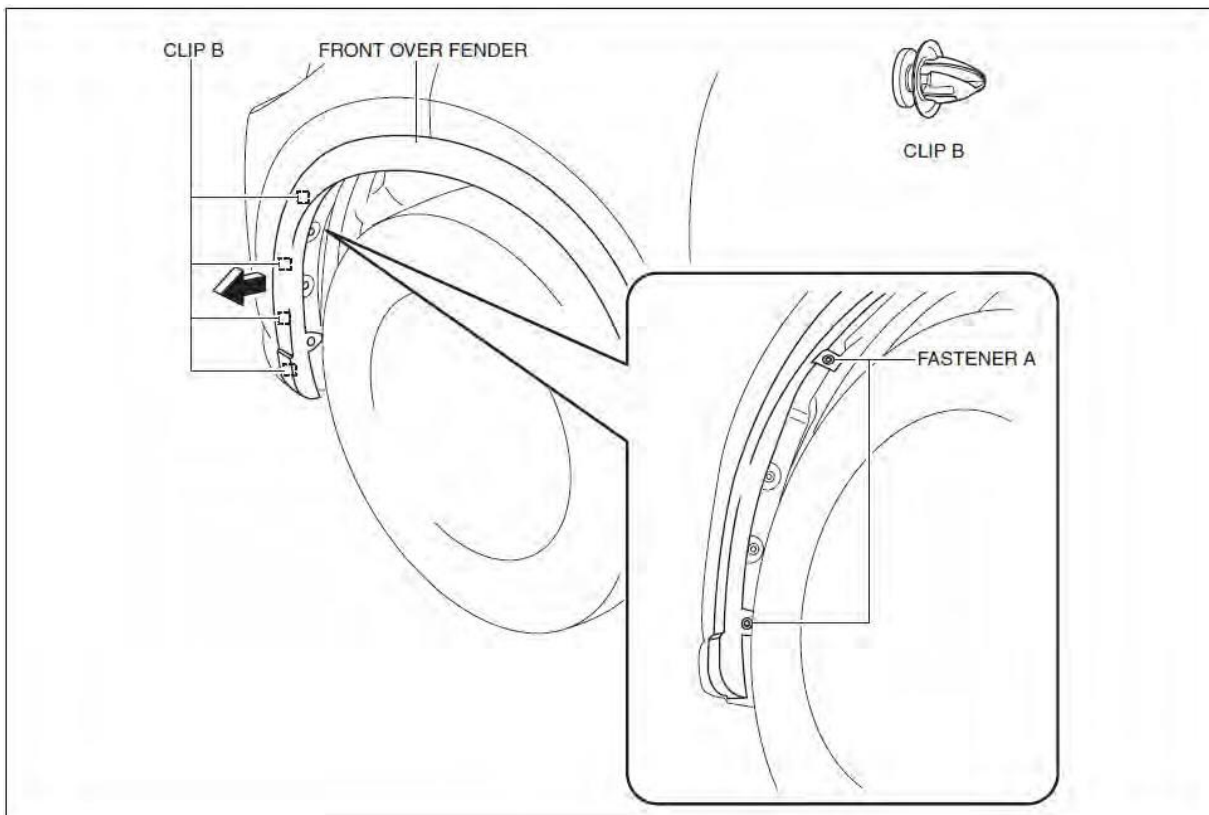

3. Pull the front over fender in the direction of the arrow shown in the figure, set the front over fender out of the way while detaching clips B.

**Caution**

- After removing clips B, insert a rag between the front fender panel and the front over fender to prevent the front fender panel and clips B from being damaged.

4. Remove screws C.

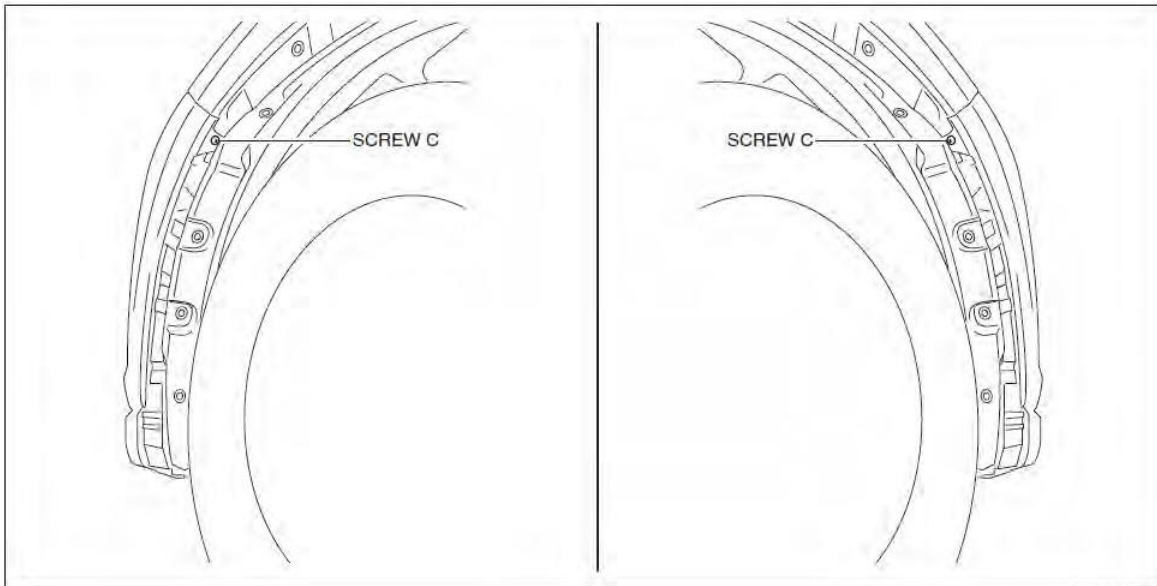

5. Remove screws D.

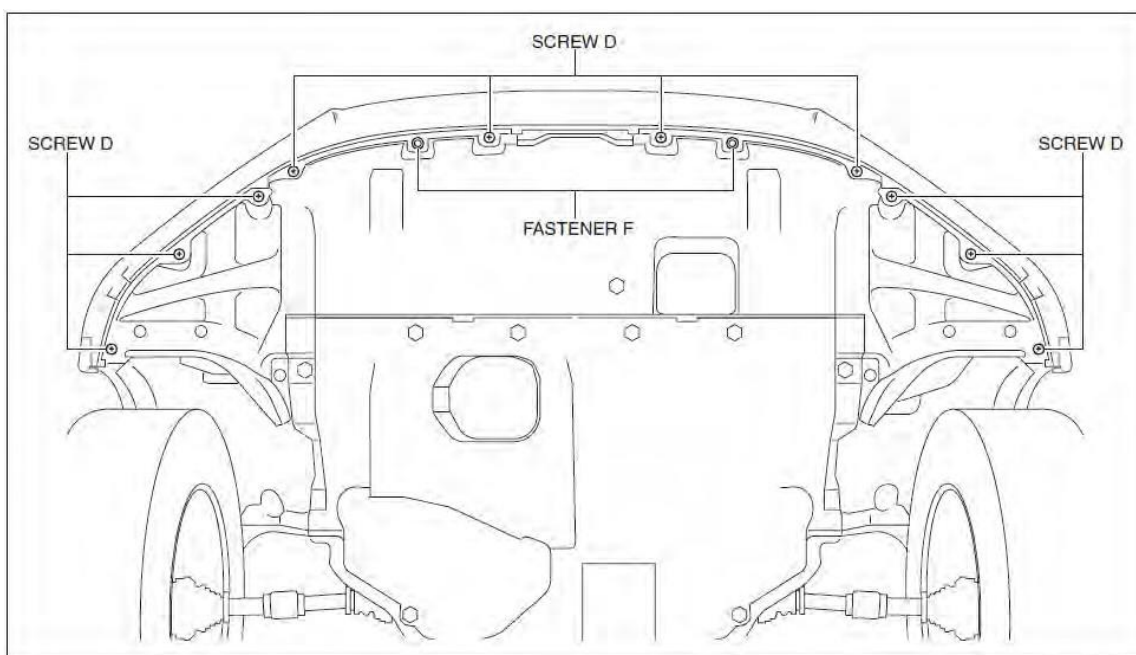



6. Remove fasteners F.
7. Remove the seal board upper. (See [SEAL BOARD UPPER REMOVAL/INSTALLATION.](#))
8. Remove fasteners G.

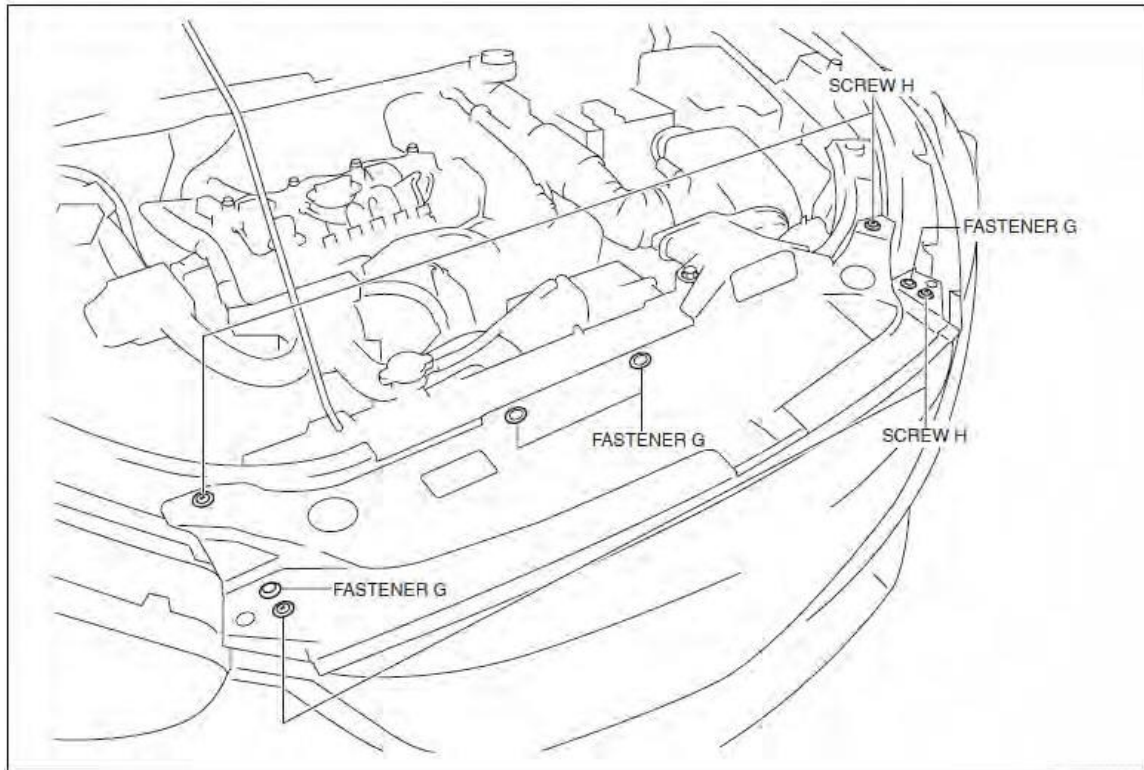

9. Remove screws H.
10. Pull the front bumper in the direction of the arrow (1) shown in the figure, then remove tabs.

**Caution**

- The front bumper and front bumper slider are engaged firmly. If they are disengaged forcibly the bumper could fall and be damaged. Perform the servicing carefully when disengaging the front bumper from the front bumper slider.
- When disengaging the front bumper from the front bumper slider, the front bumper could fall and be damaged. Support the front bumper so that it does not fall.

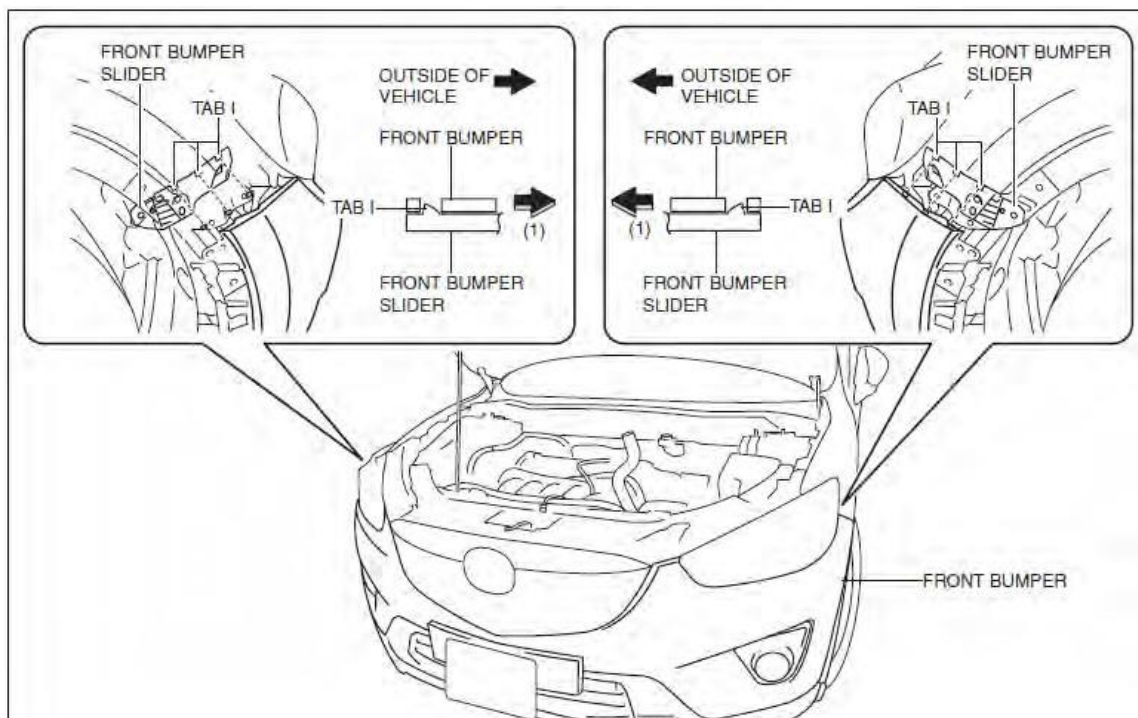

11. Remove the front bumper from the front bumper slider.
12. Pull the front bumper in the direction of the arrow (2) shown in the figure and remove it while detaching guides G.

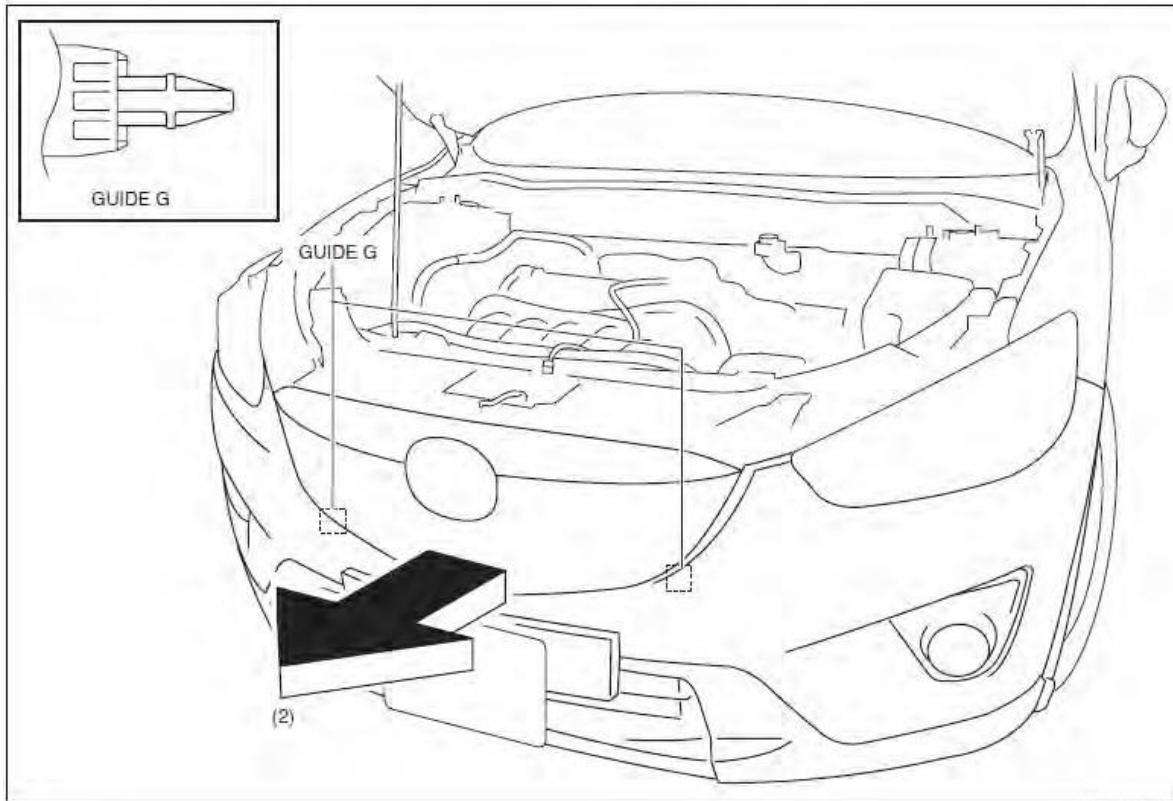

13. Disconnect the front fog light connector. (with front fog lights)
14. Disconnect the front ultrasonic sensor connector. (with parking sensor system)

**Caution**

- After removing front bumper, it may hit the front over fender and cause a damage and/or injury. Perform the following procedure to prevent the front over fender from being damaged.  
— Fix the front over fender and front fender panel with protective tape.

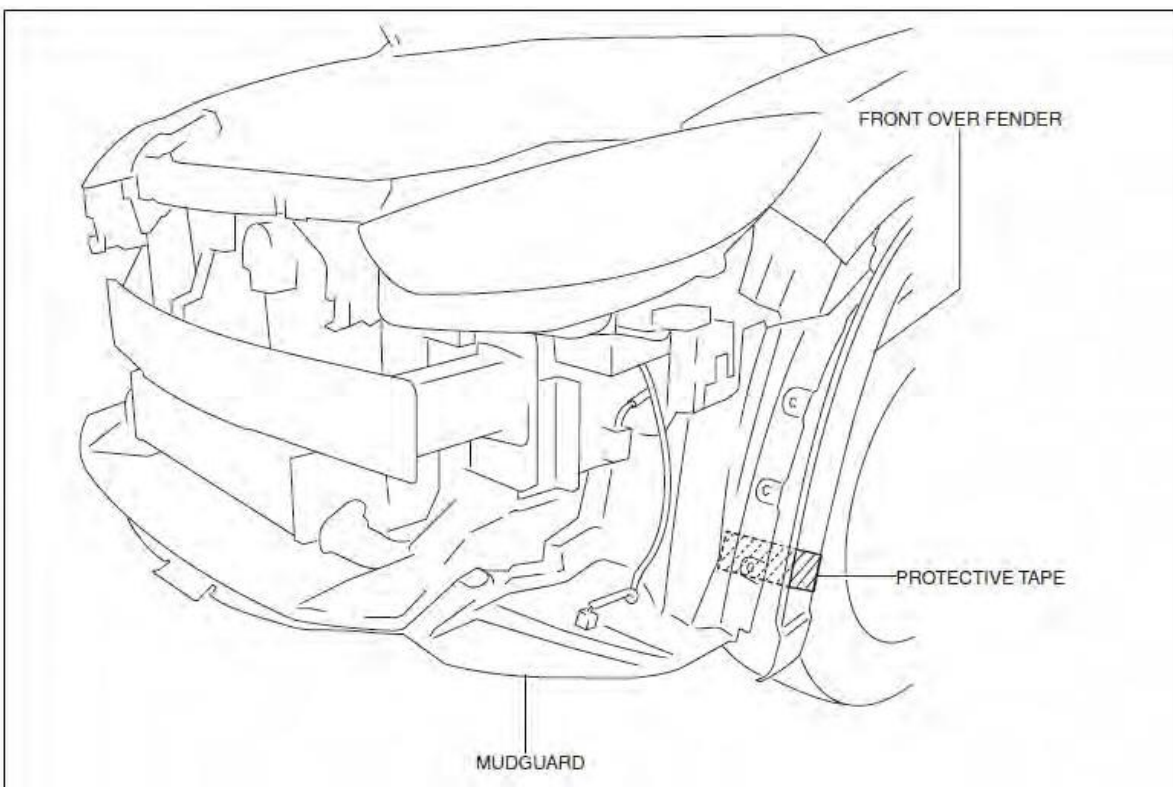

## FRONT COMBINATION LIGHT REMOVAL/INSTALLATION

### Warning

- Incorrect servicing of the discharge headlights could result in electrical shock. Before servicing the discharge headlights, always refer to the service warnings. (See DISCHARGE HEADLIGHT SERVICE WARNINGS.)

### Note

- Fogging or condensation on the inside of the front combination lights may occur due to a natural phenomenon occurring as a result of a temperature difference between the interior and exterior of the combination lights. However, it has no effect on the light performance because the temperature inside the front combination lights rises after illuminating the headlights or a period of time has elapsed.

1. Disconnect the connector.

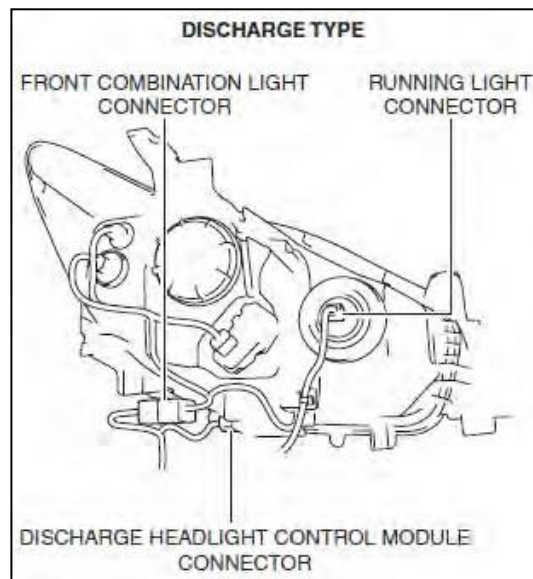

2. While pressing the clip tab in the direction of the arrows (1) shown in the figure, press the clip in the direction of the arrow (2) shown in the figure to detach the clip tab and front combination light (LH of discharge type).
3. Remove the clip (LH of discharge type).

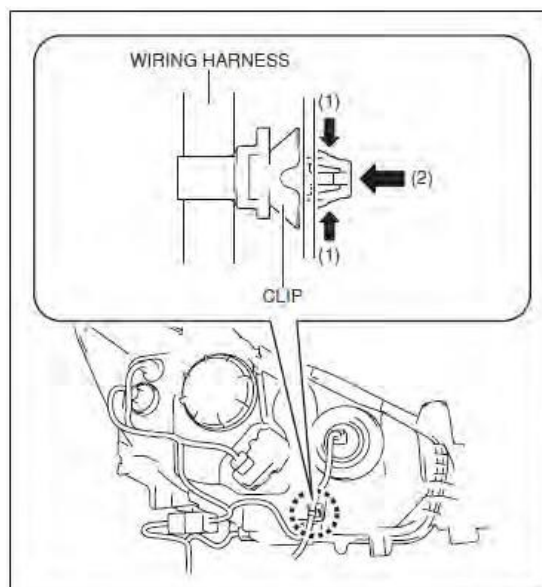

- To prevent scratches or damage, affix protective tape to the position shown in the figure.

**Caution**

- When the front combination light is removed from the body, perform the procedure after affixing protective tape to the body. Otherwise, the body could interfere with the front combination light and cause scratching or damage to the body.

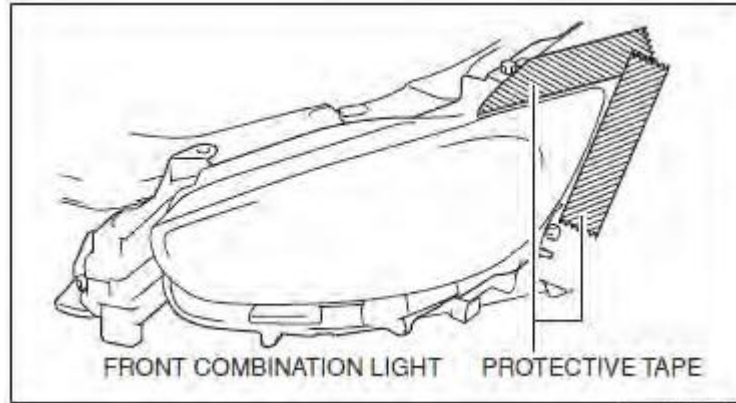

- Remove the bolts and the fastener

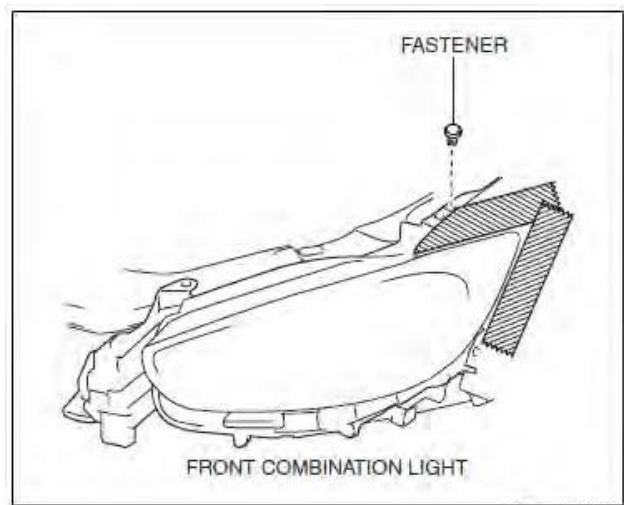
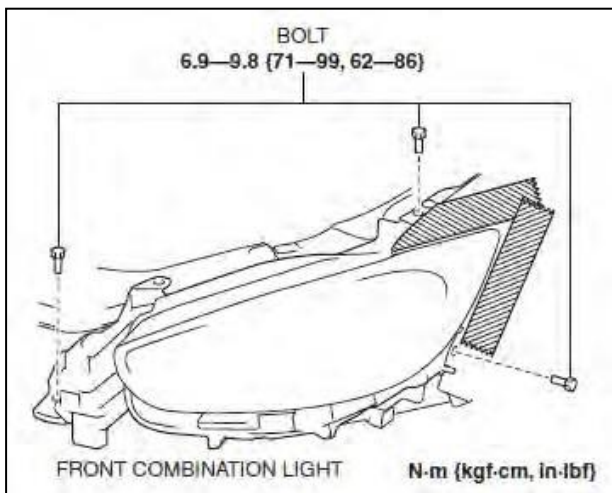

- Pull the front combination light in the direction of the arrow shown in the figure and pull out the front combination light pin from the body.

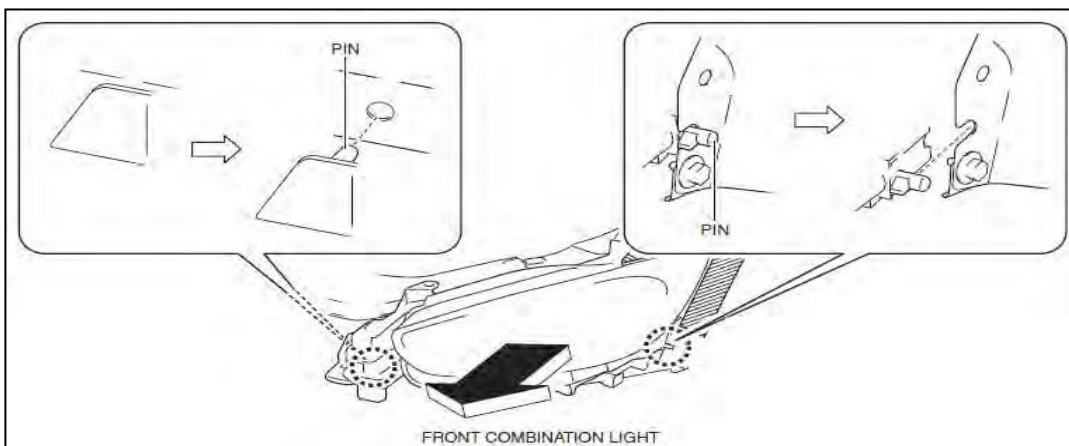

- Remove the front combination light and proceed to Step D. Gasket replacement procedure.

## D. GASKET REPLACEMENT

Replacement of gaskets for Connector A and B

Connector of headlight

A: Connector A

B: Connector B



**Caution:** Be careful not to damage the headlight lens (scratch etc...) or deform the terminal.

In order to easily reference locking/unlocking the connector, ①Make sure it is fully locked position (fully turned left and stopped position) then ②Mark before removing.

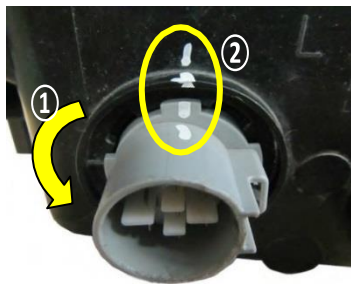

**Note:**

Recommend watching video B and replacing that gasket first along with installing the gas absorption sheet. It is the easier of the two gaskets. Then watch video A and replace connector A gasket. It will be more difficult as the connector cannot be turned 90 degrees as shown in the connector B photos below.

**Note:**

You may find a black gasket from a prior repair. Replace it anyway.

NG



OK

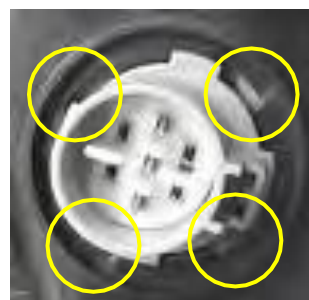

**1. Replace Gasket for Connector A**

- 1) Thread a piece of thin spare wire or string tie through the locking tab of the connector
  - \* This is to prevent the headlamp connector from falling into the headlamp assembly.

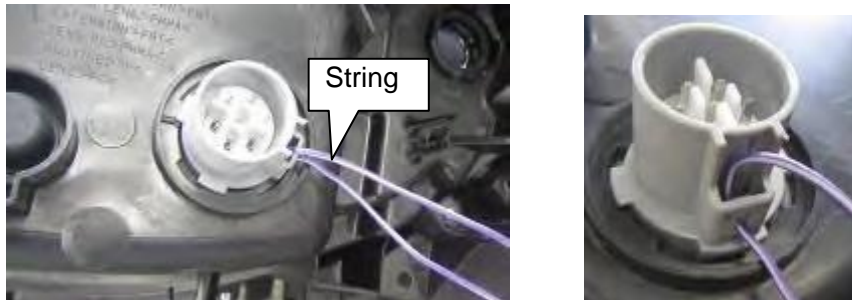

- 2) Unlock the connector from the headlamp and make room between housing and connector to allow for the removal of the gasket.
- 3) Using a pick tool, hook and pull the gasket off of the connector and out of the headlamp.



- 4) Install the gasket with new one (black one).
  - Thread the new gasket onto the spare wire/string.



- Push the gasket into the four hooks at the bottom of the connector.

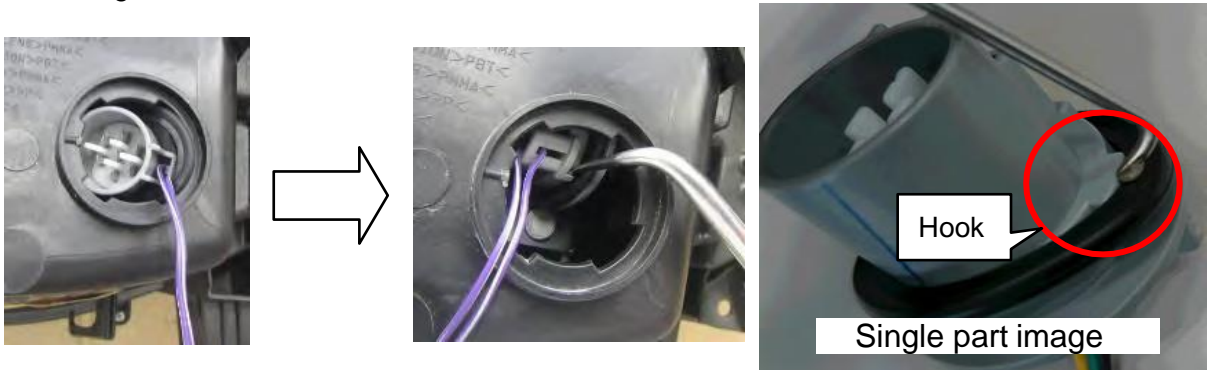

**Note: Connector A will not drop down far enough to turn 90 degrees. This gasket has limited room and visibility. Watch Video A**



①	OK: Gasket has seated.
②	NG: Gasket is not seated on the hook.



- Lock the connector shown the image below.
- Pull the spare wire/string and remove from connector.



①	OK: Fits on rib protrusion.
---	-----------------------------



## 2. Replace Gasket for Connector B.

Note: After the gasket replacement, gas absorption sheets are to be installed through connector B.

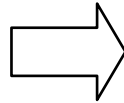
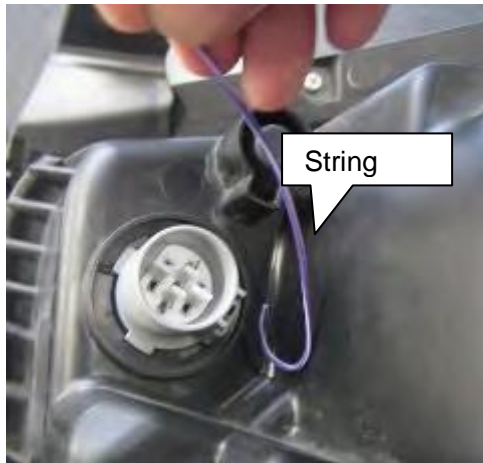

- 1) Unlock and make a gap between housing and connector.
- 2) Use a pick tool, pull the gasket toward the outside.

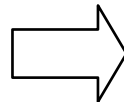

- 3) Install the gasket with new one (black one).
  - Thread the new gasket onto the spare wire or string.



- Push the gasket into the four hooks at the bottom of the connector.

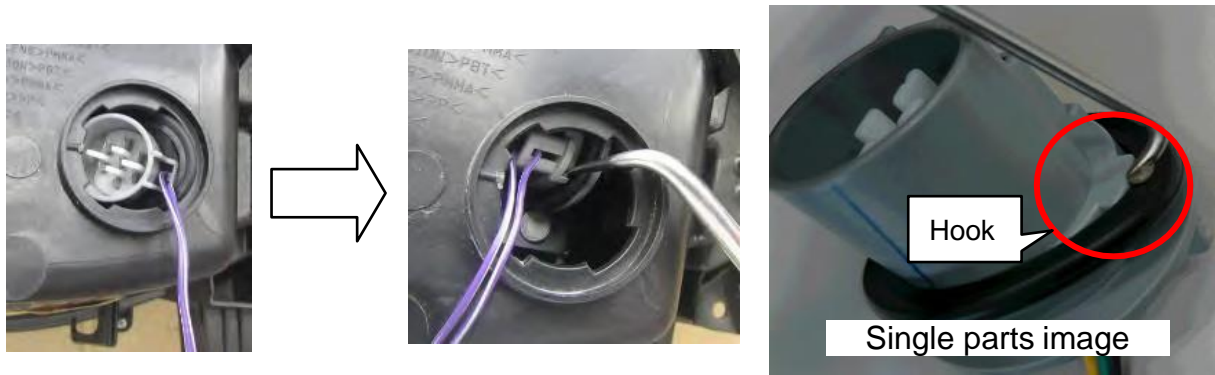

①	OK: Gasket has seated.
②	NG: Gasket comes out from the hook.



- Leave the spare wire/string at connector B for the next repair



- Go to Step E Gas absorption sheet installation procedure.

## E. GAS ABSORPTION SHEET INSTALLATION

Connector A:  
Only the gaskets  
replacement is necessary.

Connector B:  
Necessary to install gas  
absorption sheets through  
the connector B hole after  
the gaskets replacement.

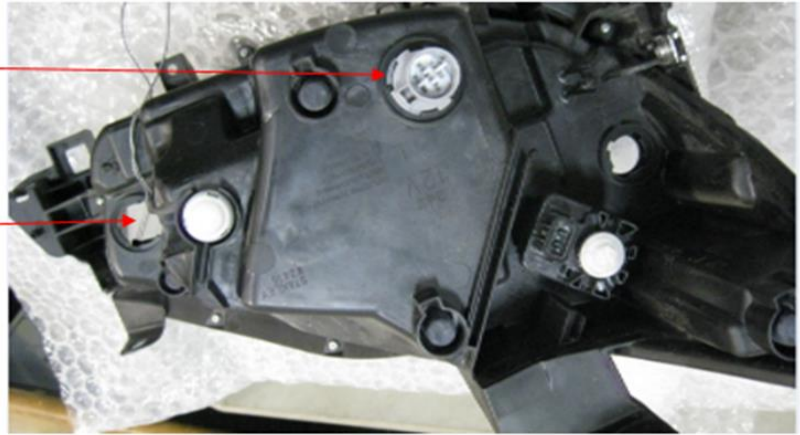

Note: Watch video.

1. Prepare a gas absorption sheet and use your finger, or tweezer, short ruler to install.
2. **Peel off the adhesive tape back of gas absorption sheet.**  
**Caution:** Do not break the ply formation of the gas absorption sheet.



3. Install gas absorption sheets **(2 pieces per one side)** inside the connector hole.



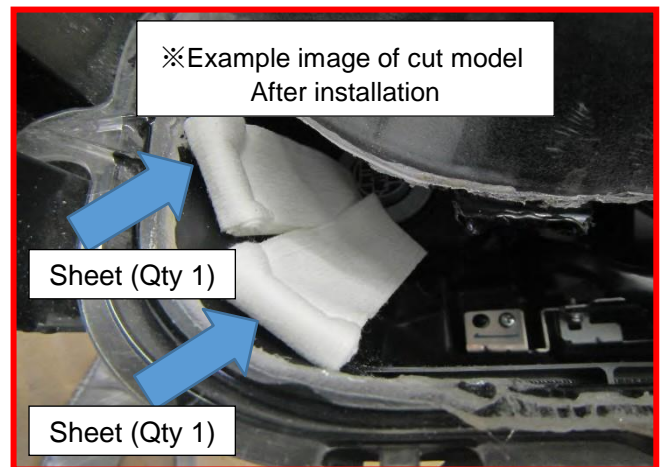
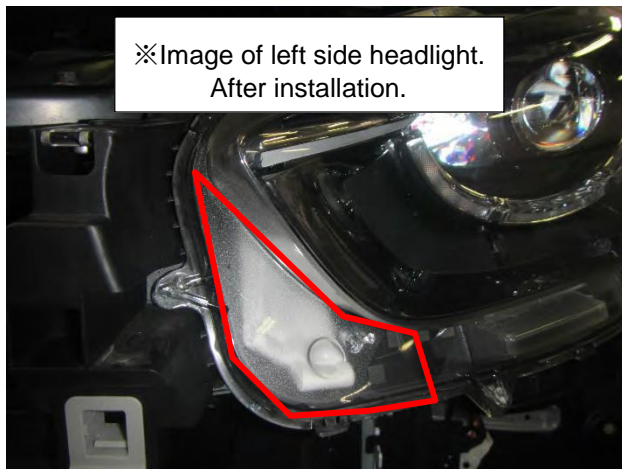

4. Lock the connector B.
5. Remove the spare wire/string from connector.
6. Make sure the connectors A & B are locked. (Confirm with the mark (in yellow circle) at fully locked position.)

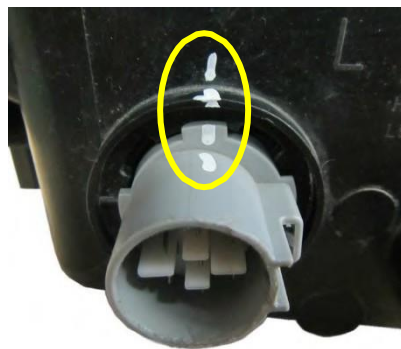

① OK: Fits on rib protrusion.

7. Repair the other headlamp if necessary. Go back to Step D
8. Reinstall the front combination light(s) in the reverse order of removal.
9. Reinstall the front bumper.
10. Check the headlight aiming.
11. Go to campaign label installation

### **3. CAMPAIGN LABEL INSTALLATION**

1. Fill out a blue "Campaign Label" (9999-95-065A-06) with Campaign No: "4320A", your dealer code, today's date.

CAMPAIGN LABEL

CAMPAIGN NO: \_\_\_\_\_

DEALER CODE: \_\_\_\_\_

DATE: \_\_\_\_/\_\_\_\_/\_\_\_\_

PIN 9999-95-065A-06

1326

2. Affix it to the hood or bulkhead as shown:

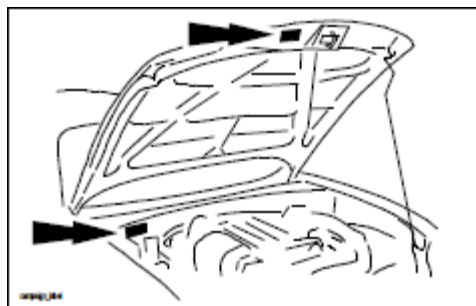

3. Return the vehicle to customer.