



Safety Recall Action Notice 570 Issue 1 - 01.2020

Subject: Side Stand Spring Replace				
Notice Number	Models Affected	VIN Range		Markets Affected
570	Thrupton 1200, Thrupton 1200 (Dual Seat), Thrupton 1200R, Thrupton 1200R (Dual Seat), Thrupton TFC	From	740405	All markets
		Up to	959980	

Background Information

Internal investigations have identified a need to replace the side stand spring on the above models. Dealers are requested to replace the side stand spring as described in the instructions below.

Customer Contact Instructions

Notice

STOP DELIVERY OF AFFECTED MOTORCYCLES IMMEDIATELY.

DO NOT deliver a motorcycle affected by this Safety Recall Action Notice to a customer until you have completed, or confirmed completion of, the procedures described in this Safety Recall Action Notice.

Delivering a motorcycle subject to an outstanding Safety Recall Action Notice may contravene local or national laws in your market, territory or country.

Triumph subsidiaries and distributors must instigate a Safety Recall Action in their country in accordance with the national recall code of practice. For vehicles in dealer stock, the safety recall MUST be actioned before delivery to the customer.

Dealers are to prioritise repair of customer owned motorcycles before any unsold motorcycles.

Identification of Affected Motorcycles

Thrupton models listed in the VIN range above.

Note:

- Some affected motorcycles listed in the VIN range will have been modified and repaired by Triumph prior to their release from the factory.
- Unmodified motorcycles can be identified by checking the 'VIN Enquiry' on www.triumphonline.net.

Warranty Claim Instructions

Notice Number	Fault Code	Repair Code	Description	Repair Allowance	Time
570	020840970	99570	SB570 - Remove and replace side stand spring	0.08 Hours	

Genuine Parts Information

Notice Number	Part Number	Part Description	Quantity
570	T2083537	Spring, side stand	1

Parts Ordering Instructions

For Triumph Subsidiary and Overseas Distributor dealers using Triumph Warranty On-Line with Parts Auto Ordering Flag switched on: Order all repair parts by submitting a New Prior through the Warranty On-Line system. Entering the above repair code in a New Prior will automatically add the parts required and labour times for this Safety Recall Action Notice.

For Overseas Distributor dealers NOT using Triumph Warranty On-Line or for Overseas Distributor dealers using Triumph Warranty On-Line with Parts Auto Ordering Flag switched off: Orders should be placed using the normal parts ordering procedure.

Genuine Parts Return

Dealer to retain parts for 90 days. All parts must be stored in a secure, non-public accessed area and correctly identified with a completed warranty label. Thereafter the parts must be rendered unusable prior to scrapping.

Side Stand Spring Replacement

Warning

Make sure the motorcycle is stabilised and adequately supported.
A correctly supported motorcycle will help prevent it from falling.
An unstable motorcycle may fall, causing injury to the operator or damage to the motorcycle.

Warning

If the motorcycle has recently been running, some components may be hot to the touch. Contact with the hot components may cause damage to exposed skin. To avoid skin damage, always allow the hot parts to cool before working on the motorcycle.

Warning

Wear hand, eye and face protection when unhooking the stand spring. Take great care to minimise the risk of personal injury and loss of components.

1. Raise and support the motorcycle.

- With the side stand in its retracted position as shown below, unhook the spring from the side stand noting the spring hook orientation, and remove it from the motorcycle.

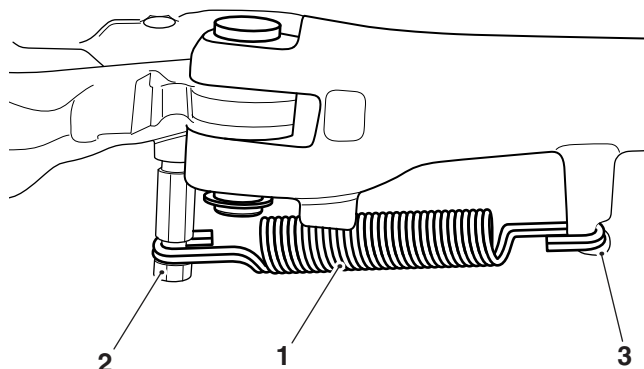

- Side stand spring (to be replaced)**
- Retainer peg**
- Side stand lug**

- In the same orientation as the original spring, hook the new side stand spring and rubber sleeve onto its retainer peg then carefully hook it onto the side stand lug. Do not remove the rubber sleeve.
- Check the operation of the side stand. Ensure the spring holds the stand securely in the retracted position.
- Lower the motorcycle to the ground and park it on the side stand.

Other Instructions

Once completed, please mark the Service Record Book that the requirements of this Safety Recall Action Notice have been complied with.

Before returning the motorcycle to the customer, download the latest calibration to the engine electronic control module, chassis electronic control module (if fitted), keyless electronic control module (if fitted) and instruments (if applicable) using the current version of the Triumph diagnostic software.

Circulation

Initial and date when read and return to central file holder

Service Manager	Parts Manager	Sales Manager	Workshop Supervisor	Technician 1	Technician 2