

# TECHNICAL INSTRUCTIONS

FOR

## SAFETY RECALL 20TA02

### VEHICLE MAY STALL DURING DRIVING AT HIGHER SPEED

2018 – 2019 Sequoia  
2018 – 2019 Tundra

2018 – 2019 Camry  
2014 FJ Cruiser

2019 Avalon  
2014 4Runner

The remedy for this campaign is being launched in phases. Confirm remedy eligibility on each VIN in TIS before starting any repairs.

The repair quality of covered vehicles is extremely important to Toyota. All dealership technicians performing this recall are required to successfully complete the most current version of the E-Learning course “Safety Recall and Service Campaign Essentials”. To ensure that all vehicles have the repair performed correctly; technicians performing this recall repair are required to currently hold at least one of the following certification levels:

- Certified (any specialty)
- Expert (any specialty)
- Master
- Master Diagnostic Technician

It is the dealership’s responsibility to select technicians with the above certification level or greater to perform this recall repair. Carefully review your resources, the technician skill level, and ability before assigning technicians to this repair. It is important to consider technician days off and vacation schedules to ensure there are properly trained technicians available to perform this repair at all times.

# I. OPERATION FLOW CHART

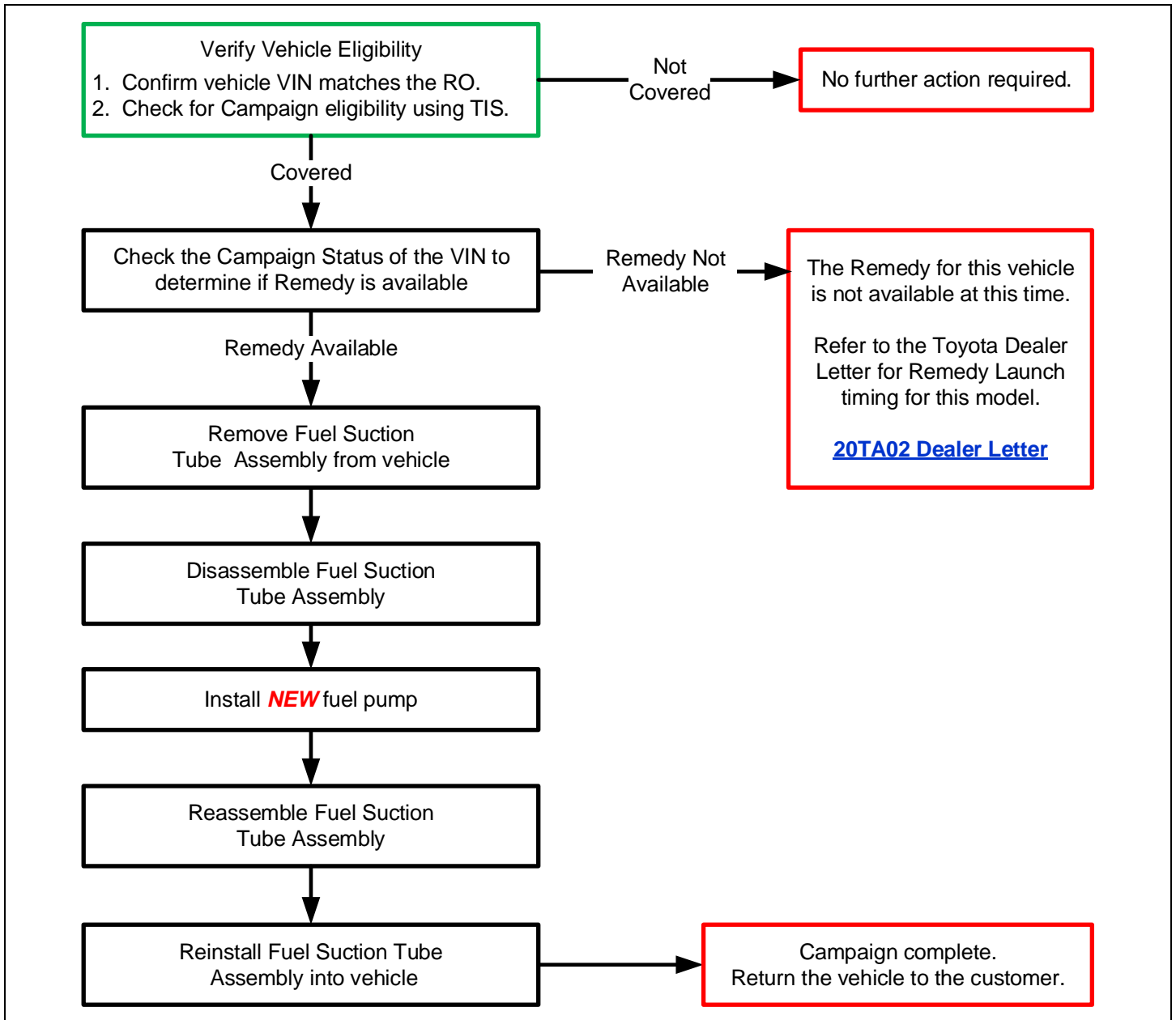

## II. IDENTIFICATION OF AFFECTED VEHICLES

### 1. CHECK VEHICLE FOR CAMPAIGN ELIGIBILITY

- Compare the vehicle's VIN to the VIN listed on the Repair Order to ensure they match.
- Check the TIS Vehicle Inquiry System or Service Lane to verify this vehicle is eligible for Safety Recall 20TA02.
- Determine the **Campaign Status** for Safety Recall 20TA02.

**Campaign Description:** Safety Recall 20TA02 (Remedy Notice), Multiple  
**Campaign Status:** ??????????  
**Completion Status:** **Not Completed**

What is the **Campaign Status** of Safety Recall 20TA02 for this vehicle?

Remedy Available

Remedy **NOT** Available

Continue to Section III.  
PREPARATION on p.4

**DO NOT PROCEED!!** Check the VIN again at a later date for Remedy availability.



**DO NOT PROCEED with these instructions if the Campaign Status shows Remedy Not Available!**

The remedy for this campaign is being launched in phases. Confirm remedy eligibility on each VIN in TIS before starting any repairs.

Launch timing specific to each model is available in the [20TA02 Dealer Letter](#).

Note: Warranty will not reimburse dealers for repairs completed on vehicles that are not affected or were previously completed, even by another dealer. In addition, warranty claims will not be processed for vehicles that are not yet eligible for the remedy.

### III. PREPARATION

#### A. PARTS

Because of the extensive list of parts for the numerous models affected by this Safety Recall, a website has been created to detail the required parts for each vehicle. Reference the following website for a detailed parts list for **each specific VIN**:

<https://20ta02.imagespm.info>

**Note: Warranty will only reimburse dealers for the part numbers listed on the website. Any other part numbers will not be accepted on the campaign claim.**

#### B. TOOLS & EQUIPMENT

- Standard Hand Tools
- Torque Wrench
- Air Blow gun
- Gas Caddy (minimum 25 gallon capacity)

#### C. MATERIALS

- Brake Cleaner





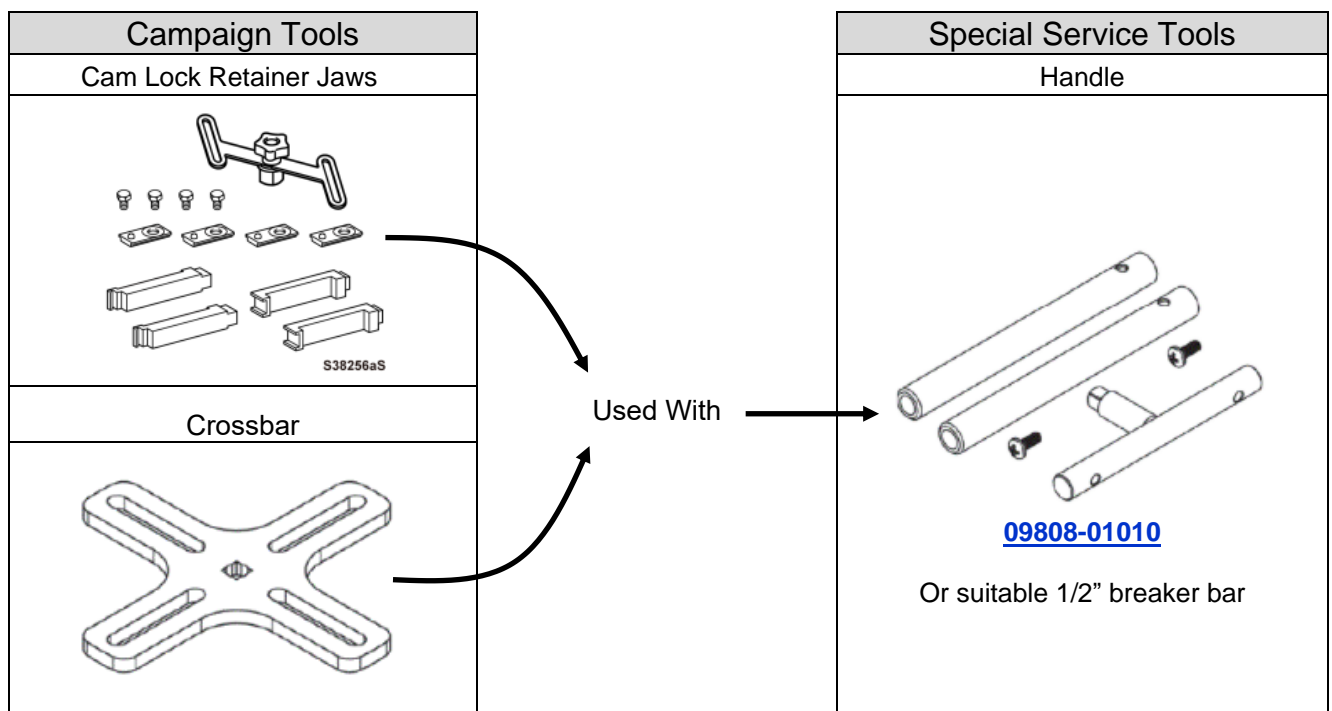

#### D. CAMPAIGN TOOLS

Prior to the launch of this Campaign, each dealership will receive a Crossbar and a set of Cam Lock Retainer Jaws for removing the Cam Lock type retainer rings. These jaws will be used with the dealerships existing Handle set from the Fuel Sender Lock Nut Wrench Set (09808-14031). A 1/2" breaker bar can also be used. This set of tools will supplement the SST kit that each dealership currently has. The Campaign tools were sent directly to the dealership's Service Manager. Additional SST's can be purchased through the [Toyota Special Service Tools \(SST\)](#) website.

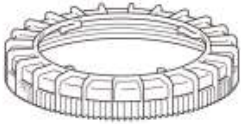

### C. Special Service Tools

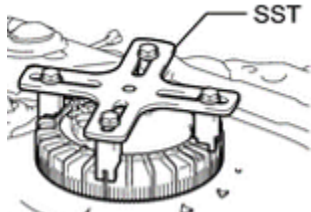
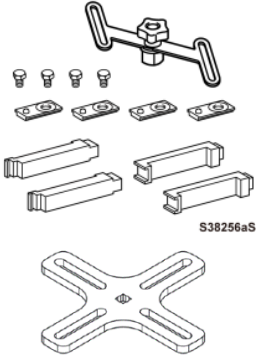
In the affected models, there are three different types of Fuel Pump Retainer Rings. Reference the following chart to determine the proper SST or campaign tool for each model and retainer type.

RETAINER TYPE			
Type:	Bolt In 	Cam Lock 	Plastic Ring 
SST:	No SST Required	 Fuel Sender Lock Nut Wrench Kit <a href="#">(09808-14031)</a> Claw: 105mm Jaw Set <a href="#">(09808-01070)</a> Crossbar <a href="#">(09808-01030)</a>	 Fuel Sender Lock Nut Wrench Kit <a href="#">(09808-14031)</a> Option 1: Claw: 50mm Jaw Set <a href="#">(09808-01040)</a> Option 2: Claw: Sliding jaw <a href="#">(09808-01080)</a> Crossbar <a href="#">(09808-01030)</a>
Special Notes:		<p><b>Campaign Tool:</b> Cam Lock Retainer Jaws</p>  Requires use of the Handle from the Fuel Sender Lock Nut Wrench Kit, or a 1/2" breaker bar.	<p><b>Aftermarket alternative:</b> CTA Tools 1044 Fuel Tank Lid Wrench</p>  This tool is available from <a href="#">Autopart.com</a> Or contact <a href="#">CTA Tools</a> at <a href="mailto:info@ctatools.com">info@ctatools.com</a> for purchasing inquiries
Models:	Avalon (2018)	Avalon (2019) Camry	4Runner Sequoia Tundra FJ Cruiser

Additional SST's can be purchased from the [Toyota Special Service Tools](#) (SST) website

## IV. BACKGROUND

The subject vehicles are equipped with a low-pressure fuel pump which may stop operating. If this were to occur, warning lights and messages may be displayed on the instrument panel, and the engine may run rough. This may result in a vehicle stall, and the vehicle may be unable to be restarted. If a vehicle stall occurs while driving at higher speeds, this could increase the risk of a crash.

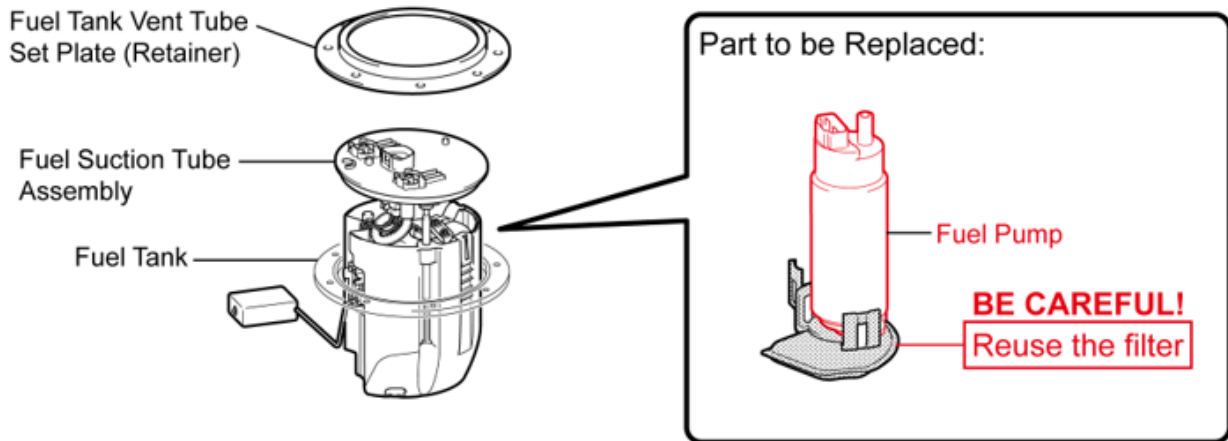

\*The configuration of the parts will differ depending on the specification.

S38182aSU

## V. SAFETY PRECAUTIONS

### CAUTION:

- When installing/uninstalling the fuel system components, keep safety first in mind and carefully observe the following instructions to avoid accidents:
  - a. When working on the fuel system, display a Flammable - Keep Fire Away sign.
  - b. Smoking is prohibited nearby.
  - c. Perform this work in an area where there are no sparks nearby from the operation of welders, grinders, drills, electric motors, stoves, etc.
  - d. **DO NOT** use electrical devices nearby because they can become hot and the operation of power switches can generate sparks.
  - e. **DO NOT** use iron or steel hammers while working, because they may generate sparks.
  - f. **DO NOT** start engines even in adjacent stalls.
  - g. Prepare fire extinguishers before starting any work.
  - h. Perform this work in a well-ventilated area (natural ventilation). **DO NOT** use exhaust fans or electric fans, because their motors might generate sparks.
  - i. Since it is possible for fuel vapor to build up, **DO NOT** work in or near a pit.
  - j. If fuel is spilled, use shop towels or similar material to quickly wipe it up and then use compressed air to diffuse the fuel vapor.
  - k. Shop towels and other materials that have come into contact with fuel should be dried in a well-ventilated area and then disposed of as appropriate.

## VI. COMPONENTS

14MY 4Runner

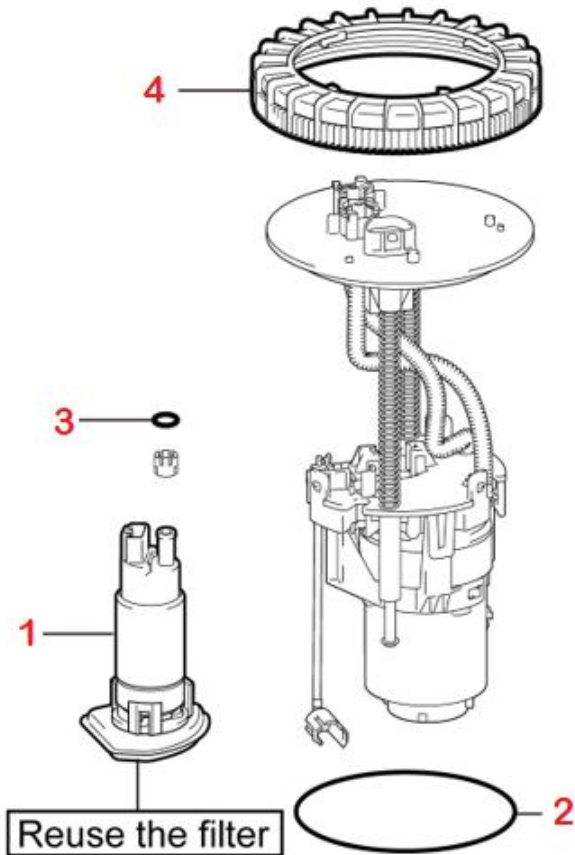

Replacement Items in red

No.	Contents of Part Kit's	Quantity	Tape Color	Remarks
1	FUEL PUMP	1		
2	FUEL SUCTION TUBE SET GASKET	1		
3	O-RING	1	Yellow	15.2mm
4	FUEL PUMP GAUGE RETAINER	1		

DO NOT order the individual parts listed here. It is provided as a reference to assist in the correct installation. Order the parts kit's specific to each VIN, as detailed in the parts lookup website (p. 4). Warranty will only reimburse dealers for the part numbers listed on the website. Any other part numbers will not be accepted on the campaign claim.

**AVALON 2019**

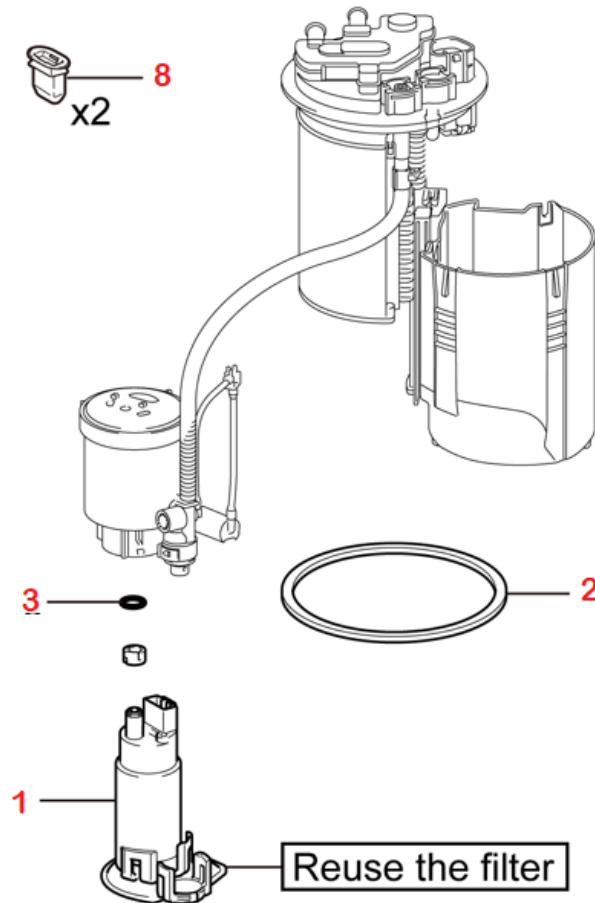

Replacement items in red

No.	Contents of Part Kit's	Quantity	Tape Color	Remarks
1	FUEL PUMP	1		
2	FUEL SUCTION TUBE SET GASKET	1		
3	O-RING	2*	Gold	15.2mm
4	REAR SEAT CUSHION LOCK HOOK	2		Not used
5	O-RING	1	Red	Not used
6	O-RING	1	Green	Not used
7	FUEL TANK PIPE SETTING HOLDER	1	White	Not used
8	REAR SEAT CUSHION LOCK HOOK	2		

\*only 1 O-Ring will be used. Discard the 2<sup>nd</sup> O-Ring.

DO NOT order the individual parts listed here. It is provided as a reference to assist in the correct installation. Order the parts kit's specific to each VIN, as detailed in the parts lookup website (p. 4). Warranty will only reimburse dealers for the part numbers listed on the website. Any other part numbers will not be accepted on the campaign claim.

Note: Some items in the Fuel Pump Replacement Kit will not be used.

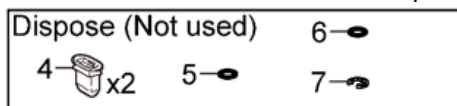



# CAMRY



Replacement items in red

No.	Contents of Part Kit's	Quantity	Tape Color	Remarks
1	FUEL PUMP	1		
2	FUEL SUCTION TUBE SET GASKET	1		
3	O-RING	2*	Gold	15.2mm
4	REAR SEAT CUSHION LOCK HOOK	2		Not used
5	O-RING	1	Red	Not used
6	O-RING	1	Green	Not used
7	FUEL TANK PIPE SETTING HOLDER	1	White	Not used
8	REAR SEAT CUSHION LOCK HOOK	2		

\*only 1 O-Ring will be used. Discard the 2<sup>nd</sup> O-Ring.

DO NOT order the individual parts listed here. It is provided as a reference to assist in the correct installation. Order the parts kit's specific to each VIN, as detailed in the parts lookup website (p. 4). Warranty will only reimburse dealers for the part numbers listed on the website. Any other part numbers will not be accepted on the campaign claim.

Note: Some items in the Fuel Pump Replacement Kit will not be used.

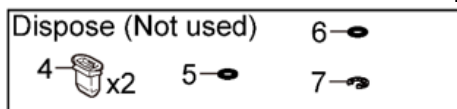

# FJ CRUISER

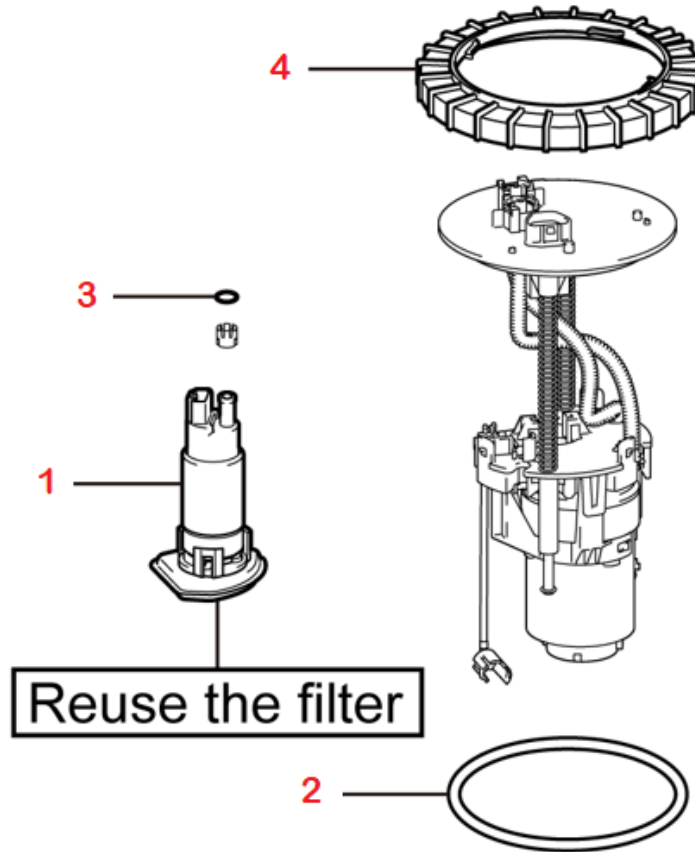

Replacement items in red

No.	Contents of Part Kit's	Quantity	Tape Color	Remarks
1	FUEL PUMP	1		
2	FUEL SUCTION TUBE SET GASKET	1		
3	O-RING	1	Yellow	15.2mm
4	FUEL PUMP GAUGE RETAINER	1		

DO NOT order the individual parts listed here. It is provided as a reference to assist in the correct installation. Order the parts kit's specific to each VIN, as detailed in the parts lookup website (p. 4). Warranty will only reimburse dealers for the part numbers listed on the website. Any other part numbers will not be accepted on the campaign claim.

SEQUOIA  
TUNDRA

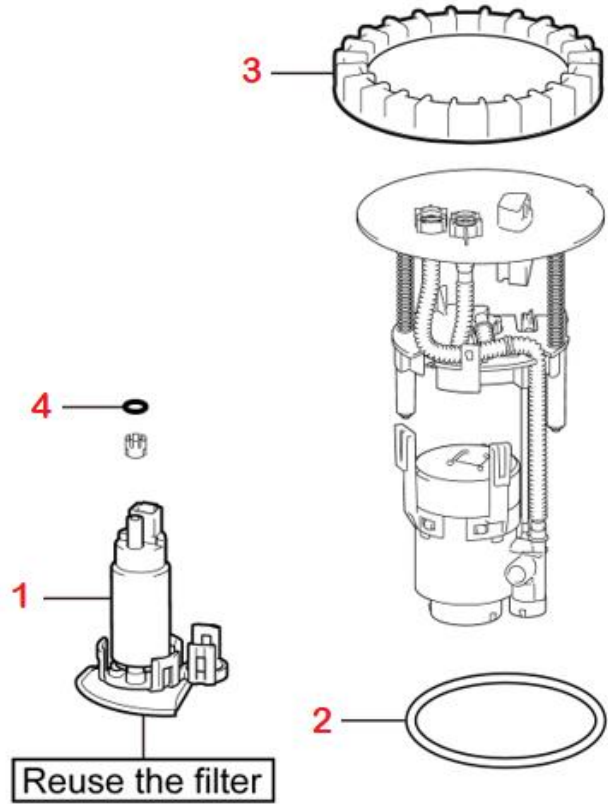

Replacement items in red

No.	Contents of Part Kit's	Quantity	Tape Color	Remarks
1	FUEL PUMP	1		
2	FUEL SUCTION TUBE SET GASKET	1		
3	FUEL PUMP GAUGE RETAINER	1		
4	O-RING	1	(not labeled)	

DO NOT order the individual parts listed here. It is provided as a reference to assist in the correct installation. Order the parts kit's specific to each VIN, as detailed in the parts lookup website (p. 4). Warranty will only reimburse dealers for the part numbers listed on the website. Any other part numbers will not be accepted on the campaign claim.

## VII. REMOVE FUEL TUBE ASSEMBLY



**Use TIS to confirm that this vehicle is eligible for the campaign before proceeding (p. 3). Warranty will not pay claims on ineligible vehicles.**



### 1. CHECK FOR DTC'S

- a. Using a Techstream, perform a Health Check to check for Diagnostic Trouble Codes.

*Note: This Safety Recall covers only the replacement of the fuel pump and associated parts. It does not cover the diagnosis or replacement of any other parts on the vehicle.*

### REMOVAL TIP: FUEL LEVEL

If the fuel level inside the fuel tank is above the specified level, fuel may overflow from the fuel tank during the removal of the fuel suction tube assembly. Confirm the fuel level in the vehicle is below the specified level before proceeding. If necessary, drain fuel from the tank.

Model	FUEL LEVEL RECOMMENDATIONS	
	Less than full	3/4 or less
4Runner Avalon Camry FJ Cruiser	✓	
Sequoia Tundra		✓

**Note:** If fuel needs to be removed from the tank, be sure to recover it into an approved fuel recovery system. Suitable systems are available from the [Toyota Approved Dealer Equipment website](#).

## REMOVAL TIP: PLASTIC RING RETAINERS

If removing the Plastic Ring type retainers, cut the 4 internal claws to prevent the Fuel Tube assembly from rotating during removal. This could cause damage to the fuel level sender, fuel tank, or fuel tube assembly.

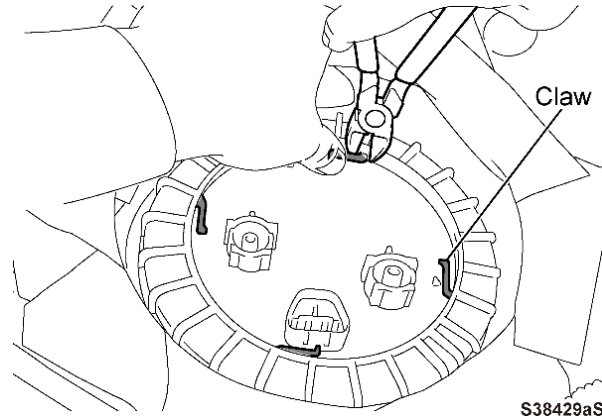

## REMOVAL TIP: TUBE ASSY ALIGNMENT

For vehicles with the plastic retainer rings, place matchmarks on both the Fuel Tube Assembly and the fuel tank. During disassembly, confirm that the Fuel Tube Assembly does not rotate. During reassembly, this will aid in aligning the locating tabs for proper installation.

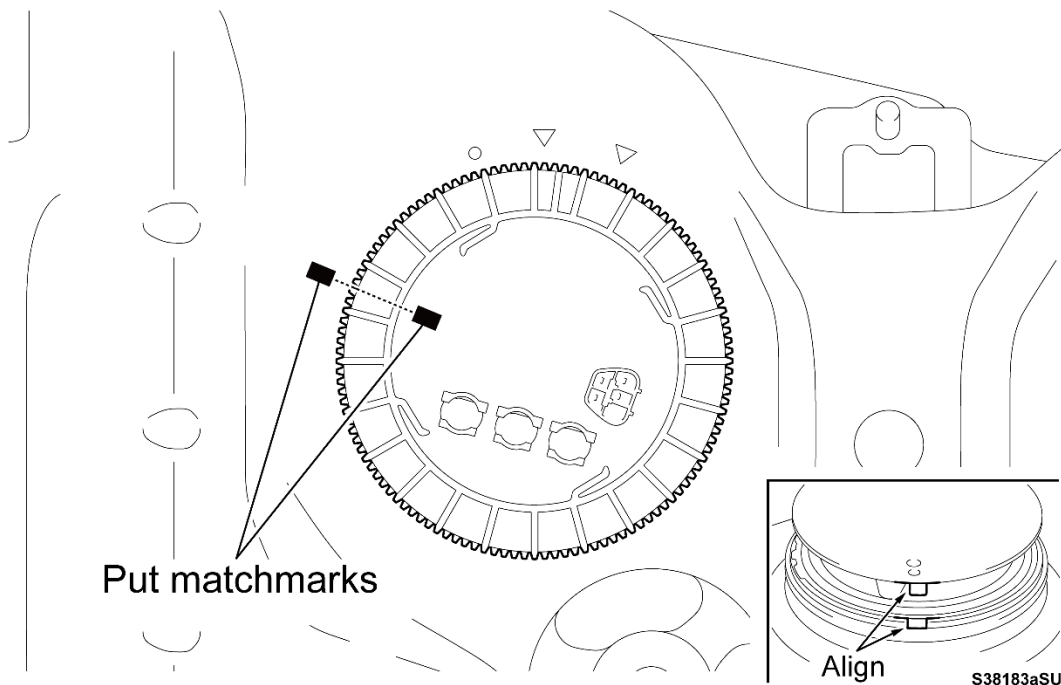

## REMOVAL TIP: CAM LOCK RETAINER TOOL

An updated set of Cam Lock Claws and Support Columns are being supplied to each dealership for this campaign. The configuration of the retainer engagement sections of the claws have been modified from the SST that is referenced in the repair manual. The **NEW** claws have an improved design that enables a firm attachment to the retainer. In addition, 2 support columns are provided which will support the retainer more securely during installation and removal. Be sure to assemble and use the tools using the following procedures:

### Campaign Tool Cam Lock Set:

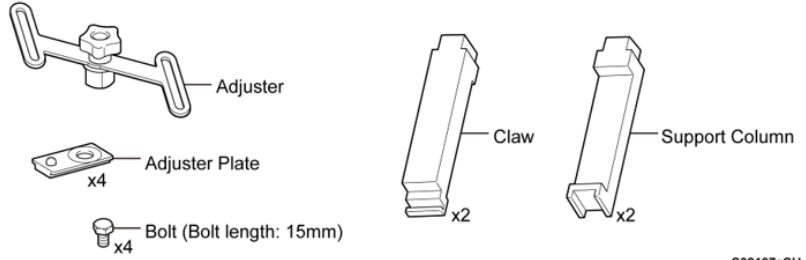

S38197aSU

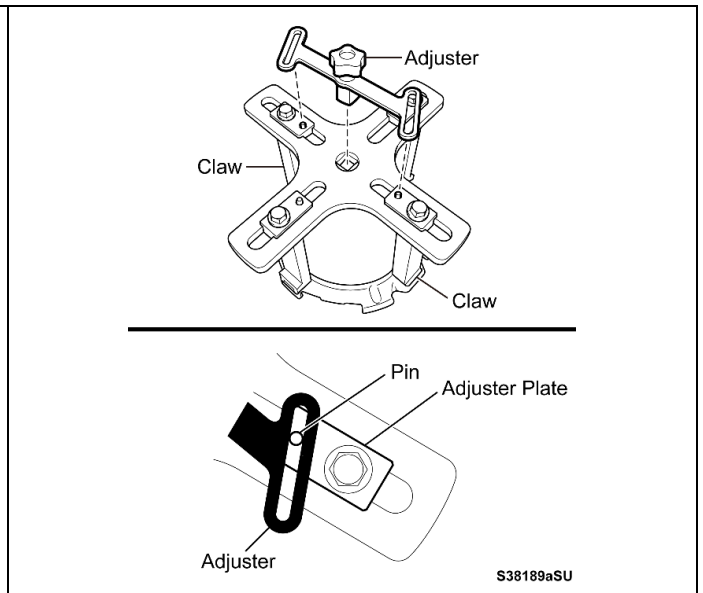
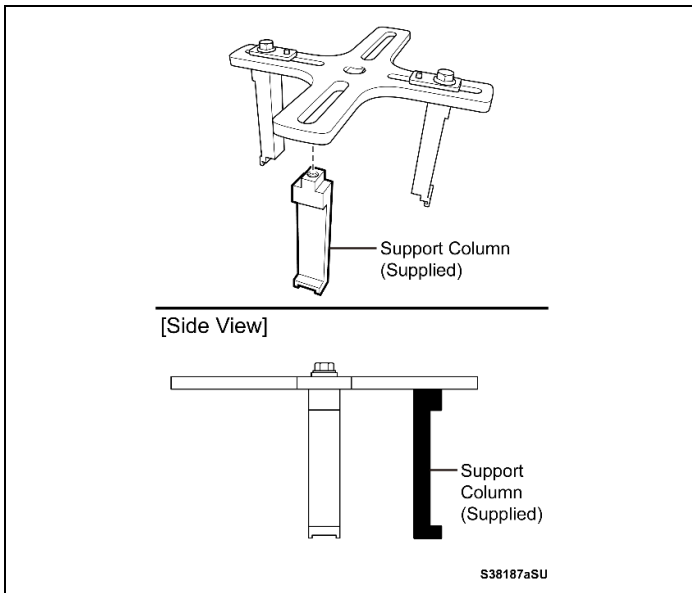
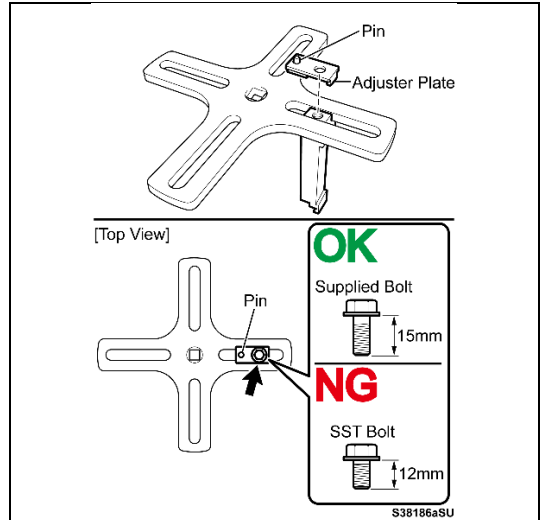
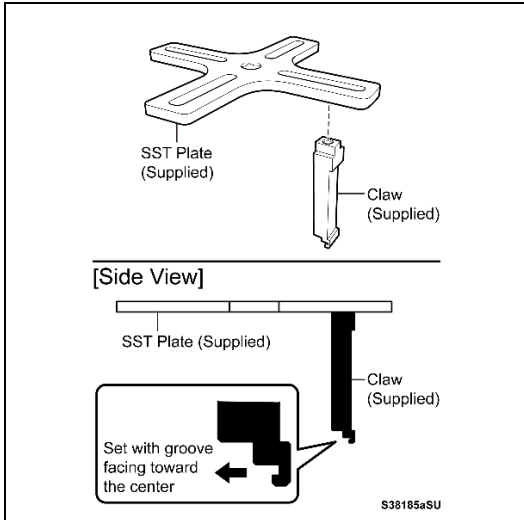

## REMOVAL TIP: CAM LOCK RETAINER TOOL (cont.)

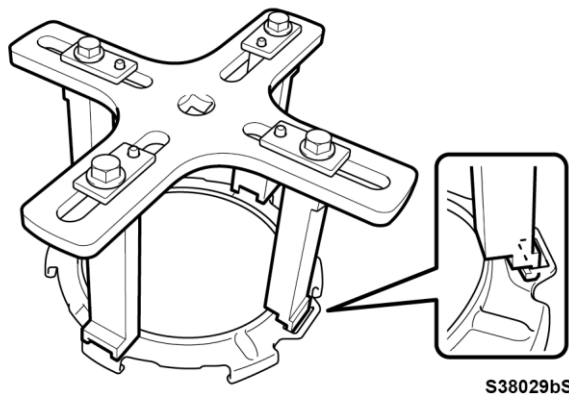

S38029bS

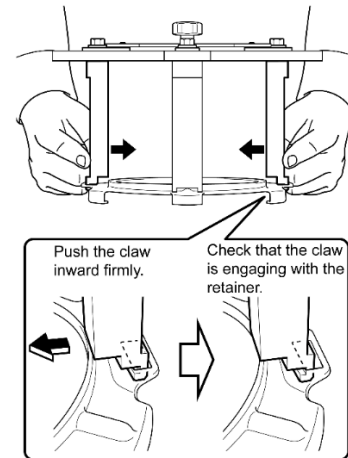

S38190aSU

OK

NG

NG

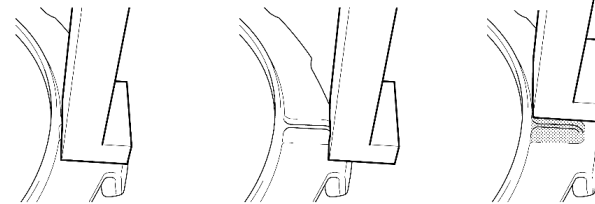

S38182aSU

Lightly tighten the adjuster

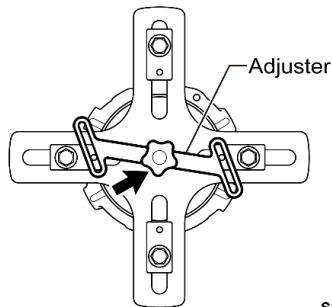

S38194aSU

Fully tighten the 4 bolts

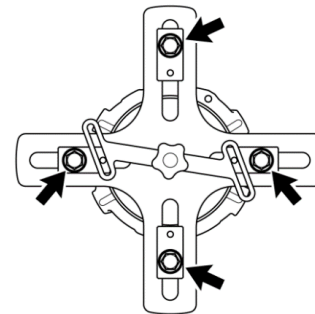

S38034aO

### 2. REMOVE FUEL TUBE ASSEMBLY FROM VEHICLE

- a. Follow the Repair Manual instructions to remove the Fuel Tube Assembly from the vehicle.

## REMOVE FUEL TUBE ASSY.

Tundra 1UR-FE 4.6	<a href="#"><u>2018</u></a>	<a href="#"><u>2019</u></a>		FJ Cruiser	<a href="#"><u>2014</u></a>
Tundra 3UR-FE 5.7	<a href="#"><u>2018</u></a>	<a href="#"><u>2019</u></a>		Avalon	<a href="#"><u>2019</u></a>
Sequoia	<a href="#"><u>2018</u></a>	<a href="#"><u>2019</u></a>		4Runner	<a href="#"><u>2014</u></a>
Camry	<a href="#"><u>2018</u></a>	<a href="#"><u>2019</u></a>			

## VIII. DISASSEMBLY OF FUEL TUBE

### DISASSEMBLY TIP: FOLLOW THE REPAIR MANUAL

The Part's Kit contains the necessary O-Rings for reassembly, if the Repair Manual procedure is followed. If the pump components are disassembled in a manor other than as detailed in the Repair Manual, the Parts Kit may not contain the necessary O-Rings for proper reassembly. Please follow the procedures in the Repair Manual to ensure the correct O-Rings are available.

#### Example of Proper Disassembly:

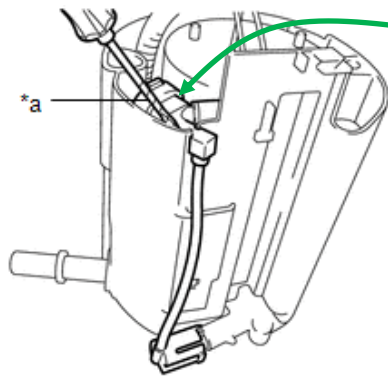

Repair Manual: Using a screwdriver (\*a) with its tip wrapped in protective tape, remove the jet pump from the No. 1 fuel sub-tank.

Tube still attached

Jet pump properly removed from the No.1 fuel sub-tank.

Replacement O-Ring will be installed in this location

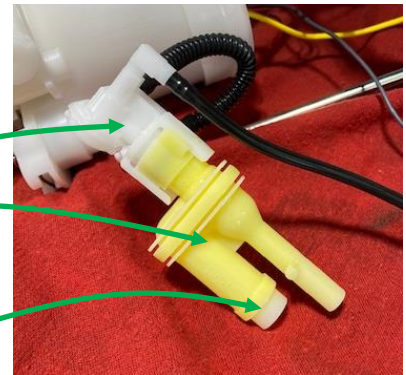

#### Example of Incorrect Disassembly:

Tube incorrectly removed from jet pump



Replacement O-ring is the incorrect size

DO NOT disconnect the tube from the jet pump

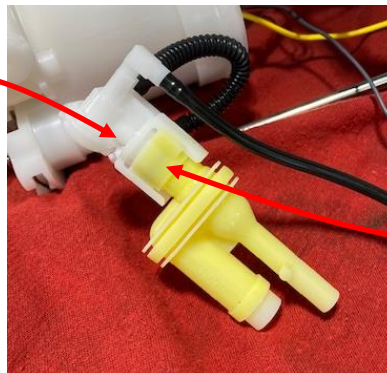

Replacement O-Ring is NOT provided for this location



## DISASSEMBLY TIP: MAIN VALVE AND REGULATOR

When replacing the fuel pump, it is not necessary to remove the Fuel Main Valve or Fuel Pressure Regulator. These O-Rings are NOT included in the parts kit.

DO NOT remove

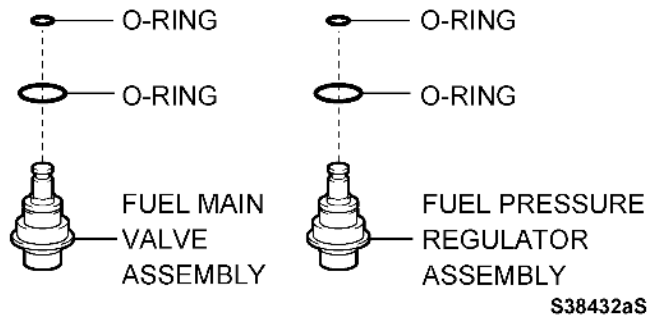

## DISASSEMBLY TIPS: FUEL FILTER

Many of the models will require the fuel filter to be reused. Be careful with the tabs when removing the filter from the original fuel pump as to not overextend them. When installing the filter on the **NEW** Fuel Pump, be sure that the clips have engaged properly.

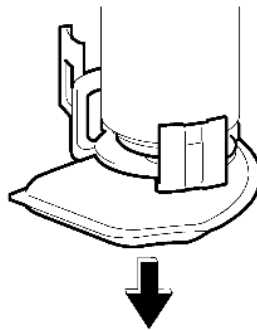

S38052aS

### 1. DISASSEMBLE FUEL SUCTION TUBE ASSEMBLY

- a. Follow the Repair Manual instructions to disassemble the Fuel Suction Tube Assembly.

## DISASSEMBLE

Tundra 1UR-FE 4.6	<a href="#"><u>2018</u></a>	<a href="#"><u>2019</u></a>		FJ Cruiser	<a href="#"><u>2014</u></a>
Tundra 3UR-FE 5.7	<a href="#"><u>2018</u></a>	<a href="#"><u>2019</u></a>		Avalon	<a href="#"><u>2019</u></a>
Sequoia	<a href="#"><u>2018</u></a>	<a href="#"><u>2019</u></a>		4Runner	<a href="#"><u>2014</u></a>
Camry	<a href="#"><u>2018</u></a>	<a href="#"><u>2019</u></a>			

## 2. CLEAN SUB TANK ASSEMBLY

- a. Using brake cleaner, clean the sub-tank assembly.

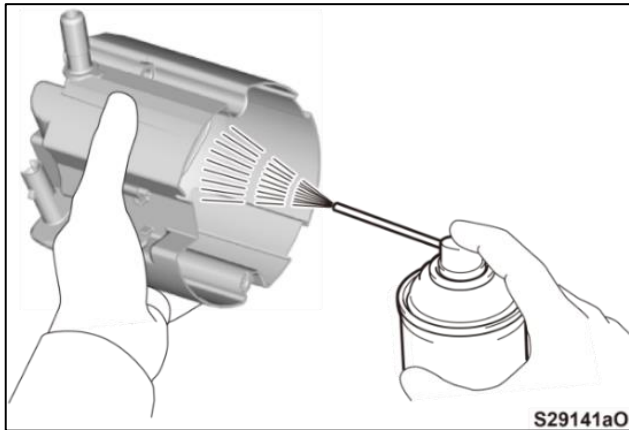

## IX. REASSEMBLE FUEL TUBE ASSEMBLY

### REASSEMBLY TIPS: O-RINGS

The part kits may come with O-Rings of different sizes. They are very difficult to tell apart visually. To identify the different size O-Rings, they will be wrapped in individual plastic bags with a piece of **COLORED TAPE** sealing it. The **COLOR OF THE TAPE** will identify the O-Ring size. **REFER TO THE COMPONENT DIAGRAMS TO DETERMINE TO CORRECT O-RING**, as identified by the tape color.

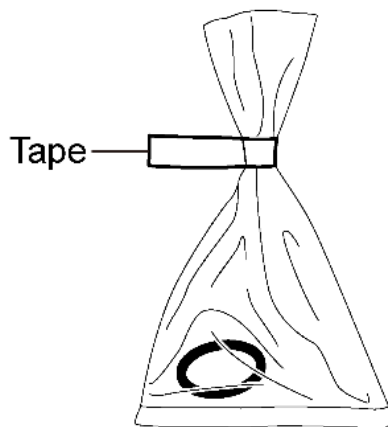

## 1. CONFIRM PARTS

- a. Using the part lookup website, input the VIN number to confirm that you have the proper parts for this vehicle:

<https://20ta02.imagespm.info>

**2. REASSEMBLE FUEL SUCTION TUBE ASSEMBLY WITH *NEW* FUEL PUMP**

a. Follow the Repair Manual instructions to reassemble the Fuel Suction Tube Assembly with a *NEW* Fuel Pump.



**Refer to the Component diagrams at the beginning of these Technical Instructions to confirm the location of each replacement part.**

**Example Procedure:**

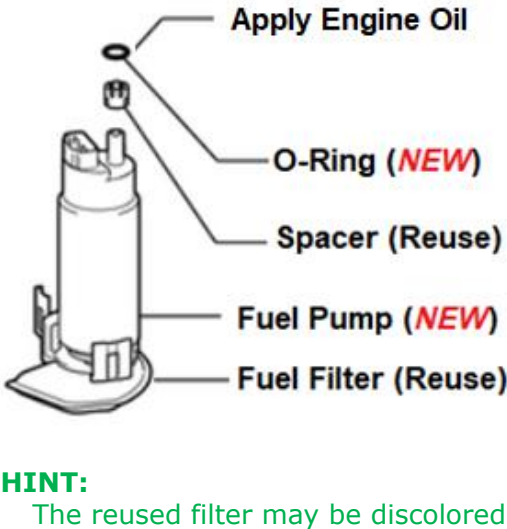
	<ul style="list-style-type: none"> <li>Remove the original O-Ring, Spacer and Fuel Filter from the original Fuel Pump.</li> <li>Discard the original O-Ring and Fuel Pump, <u>saving the Spacer and Fuel Filter.</u></li> <li>Install the original Spacer onto the <i>NEW</i> Fuel Pump.</li> <li>Install the <i>NEW</i> O-Ring onto the <i>NEW</i> Fuel Pump. Refer to the Component Diagram to determine to proper O-Ring, as identified by the colored tape on the bag.</li> <li>Apply a small amount of engine oil to the <i>NEW</i> O-Ring to assure correct installation into the Tube Assembly.</li> <li>Install the original Fuel Filter onto the <i>NEW</i> Fuel Pump.</li> <li>Refer to the <u>Components diagrams</u> to review the other <i>NEW</i> parts to install.</li> </ul>
--	--

- Apply engine oil to the *NEW* O-ring before assembly to assure correct installation into the Fuel Suction Tube.

**3. REASSEMBLE FUEL SUCTION TUBE ASSEMBLY**

b. Follow the Repair Manual instructions to reassemble the Fuel Suction Tube Assembly.

REASSEMBLE					
Tundra 1UR-FE 4.6	<a href="#"><u>2018</u></a>	<a href="#"><u>2019</u></a>		FJ Cruiser	<a href="#"><u>2014</u></a>
Tundra 3UR-FE 5.7	<a href="#"><u>2018</u></a>	<a href="#"><u>2019</u></a>		Avalon	<a href="#"><u>2019</u></a>
Sequoia	<a href="#"><u>2018</u></a>	<a href="#"><u>2019</u></a>		4Runner	<a href="#"><u>2014</u></a>
Camry	<a href="#"><u>2018</u></a>	<a href="#"><u>2019</u></a>			

## X. INSTALL FUEL TUBE ASSEMBLY

### INSTALLATION TIP: PLASTIC RETAINER

Set **NEW** gasket properly

**DO NOT** apply  
silicon grease

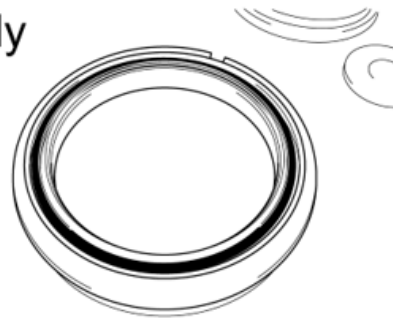

**OK**



**NG**



Put the retainer around the  
arm so that it is not necessary  
to change hands to keep  
pressing down the fuel  
suction tube.  
(Plastic Retainer)

Keep pressing down the fuel suction  
tube while installing the retainer.

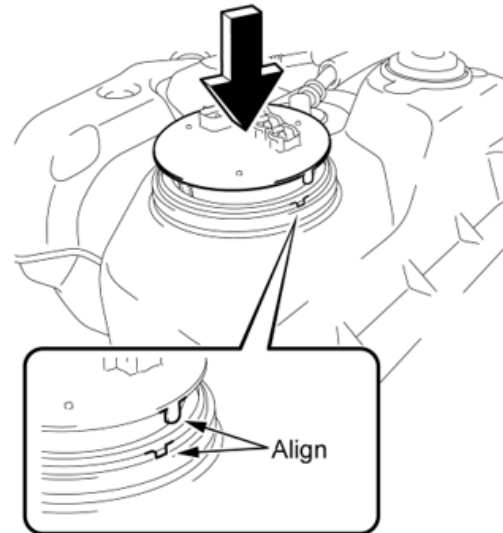
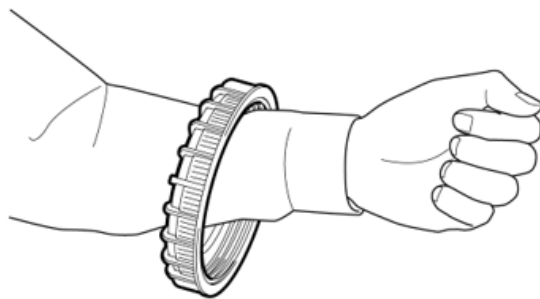

S38184aSU

## 1. INSTALL THE FUEL SUCTION TUBE ASSEMBLY INTO VEHICLE

- Follow the Repair Manual instructions to reinstall the Fuel Suction Tube into the vehicle.



Refer to the Component diagrams at the beginning of these Technical Instructions to confirm the location of each replacement part.

## INSTALLATION

Tundra 1UR-FE 4.6	<a href="#">2018</a>	<a href="#">2019</a>		FJ Cruiser	<a href="#">2014</a>
Tundra 3UR-FE 5.7	<a href="#">2018</a>	<a href="#">2019</a>		Avalon	<a href="#">2019</a>
Sequoia	<a href="#">2018</a>	<a href="#">2019</a>		4Runner	<a href="#">2014</a>
Camry	<a href="#">2018</a>	<a href="#">2019</a>			

## 2. INSTALL REMOVED FUEL

- If fuel was removed from the tank prior to disassembly, reinstall the originally recovered fuel into the tank.



## 3. CHECK FOR DTC'S

- Using a Techstream, perform a Health Check to check for Diagnostic Trouble Codes.

**Note:** This Safety Recall covers only the replacement of the fuel pump and associated parts. It does not cover the diagnosis or replacement of any other parts on the vehicle.

## ◀ VERIFY REPAIR QUALITY ▶

- Confirm no fuel leaks from vehicle
- Confirm any fuel drained from the vehicle has been reinstalled
- Test drive to confirm normal operation while under load
- Confirm no DTC's are present
- Confirm that all parts listed in the Components Diagrams have been properly installed on the vehicle.

## XI. APPENDIX

### A. PARTS DISPOSAL

In accordance with Federal law, please make sure all recalled parts (original parts) removed from the vehicle are disposed of in a manner in which they will not be reused, **unless requested for parts recovery return.**

### B. CAMPAIGN DESIGNATION DECORDER

