

**September 18, 2020**

Version 1

## Safety Recall: 2017–20 Ridgeline Accessory Tonneau Cover Attachment Information

### AFFECTED VEHICLES

Year	Model	Trim Level	VIN Range
2017–20	Ridgeline	ALL	Check the iN VIN status for eligibility.

### BACKGROUND

If the Honda Genuine accessory tonneau cover is not properly attached and secured, or the vehicle is driven with it partially open, a section of the cover may detach from the vehicle, causing a possible road hazard and increasing the risk of a crash or injury.

### CUSTOMER NOTIFICATION

Owners of all identified vehicles will be sent a notification of this campaign.

Do an iN VIN status inquiry to make sure the vehicle is shown as eligible.

Some vehicles affected by this campaign may be in your new or used vehicle inventory.

Failure to repair a vehicle subject to a recall or campaign may subject your dealership to claims or lawsuits from the customer or anyone else harmed as a result of such failure. Before selling a vehicle in inventory, always check if it is affected by a safety recall by conducting a VIN status inquiry.

### CORRECTIVE ACTION

Make sure the vehicle has a Honda Genuine accessory tonneau cover. If it does, make sure it does not already have the updated tether kit and warning labels installed.

If it does have a Honda Genuine accessory tonneau cover, and it does not have the updated tether kit and warning labels installed, install new D-rings with tether straps to the tonneau cover, install warning labels to the middle and rear panels of the cover. Then, have the service advisor give the new accessory user's information manual from the kit to the customer.

#### NOTES

- The possibility of repairs is very low compared to the population of vehicles assigned to this campaign.
- If the vehicle is not equipped with a Genuine Honda accessory tonneau cover, or it already has the updated tether kit and warning labels, submit a Campaign Status Change Request Form to the Campaign department. E-mail it to [campaign\\_change\\_request@ahm.honda.com](mailto:campaign_change_request@ahm.honda.com), or FAX it to **310-781-4823**. You need to do this to prevent the same vehicle from returning with an open campaign.

### PARTS INFORMATION

Part Name	Part Number	Quantity
Tonneau Cover Update Kit	08Z07-T6Z-100W	1

**CUSTOMER INFORMATION:** The information in this bulletin is intended for use only by skilled technicians who have the proper tools, equipment, and training to correctly and safely maintain your vehicle. These procedures should not be attempted by "do-it-yourselfers," and you should not assume this bulletin applies to your vehicle, or that your vehicle has the condition described. To determine whether this information applies, contact an authorized Honda automobile dealer.

## TOOL INFORMATION

Tool Name	Part Number	Quantity
Trim Roller	MHLE54D	1
1/4 Inch Drive Torque Wrench (Included in TPMS Sensor Service Tool Set.	CDIHONTPMSK	1

### NOTES

- All Honda dealers were sent a TPMS Sensor Service Tool Set (T/N CDIHONTPMSK) that includes a precision 1/4 inch drive torque wrench. Order it only if you do not have one.
- All Honda dealers were sent a Trim Roller (T/N MHLE54D) in March 2018 for 18-021 *Safety Recall: Second Row Outer Seat Striker Bracket (Seat Tipping)*. Order it only if you do not have one.
- If you need an additional tool, you can order it by calling the Honda Tool and Equipment Program at **1-888-424-6857**.

## WARRANTY CLAIM INFORMATION

Operation Number	Description	Flat Rate Time	Defect Code	Symptom Code	Template ID	Failed Part Number
0181A7	Install the tether kit, warning labels, and make sure the service advisor gives the new accessory user's information manual to the customer.	0.5 hr	6TP00	F8M00	A20057A	08Z07-T6Z-100F

Skill Level: Repair Technician

## INSPECTION PROCEDURE

1. Make sure the vehicle has a Honda Genuine accessory tonneau cover, and it does not have the updated tether kit and warning labels installed.

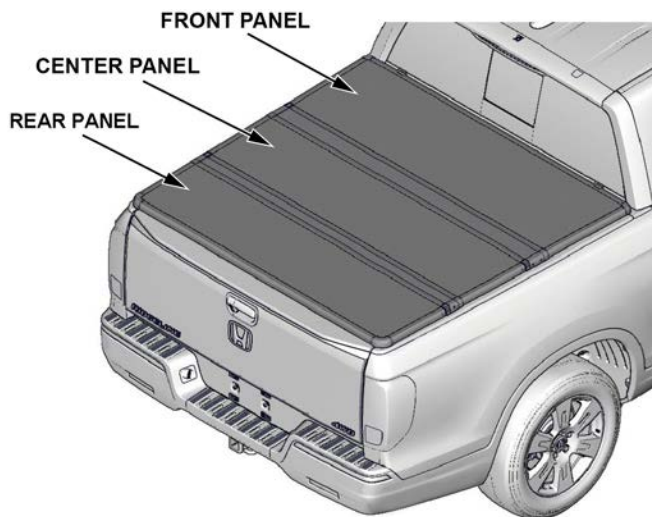

- If it is a Honda Genuine accessory tonneau cover, and it does not have the updated tether kit and warning labels, go to REPAIR PROCEDURE.
- If the vehicle is not equipped with a Honda Genuine accessory tonneau cover, or it already has the updated tether kit and warning labels, submit a Campaign Status Change Request Form to the Campaign department. E-mail it to [campaign\\_change\\_request@ahm.honda.com](mailto:campaign_change_request@ahm.honda.com), or FAX it to **310-781-4823**.

## REPAIR PROCEDURE

1. Open the tailgate.
2. Pull down the tonneau cover handle to release the hook from the rear bracket, then slide it inward while pulling down. Store the handle in the cross member. Do this step on the other side.

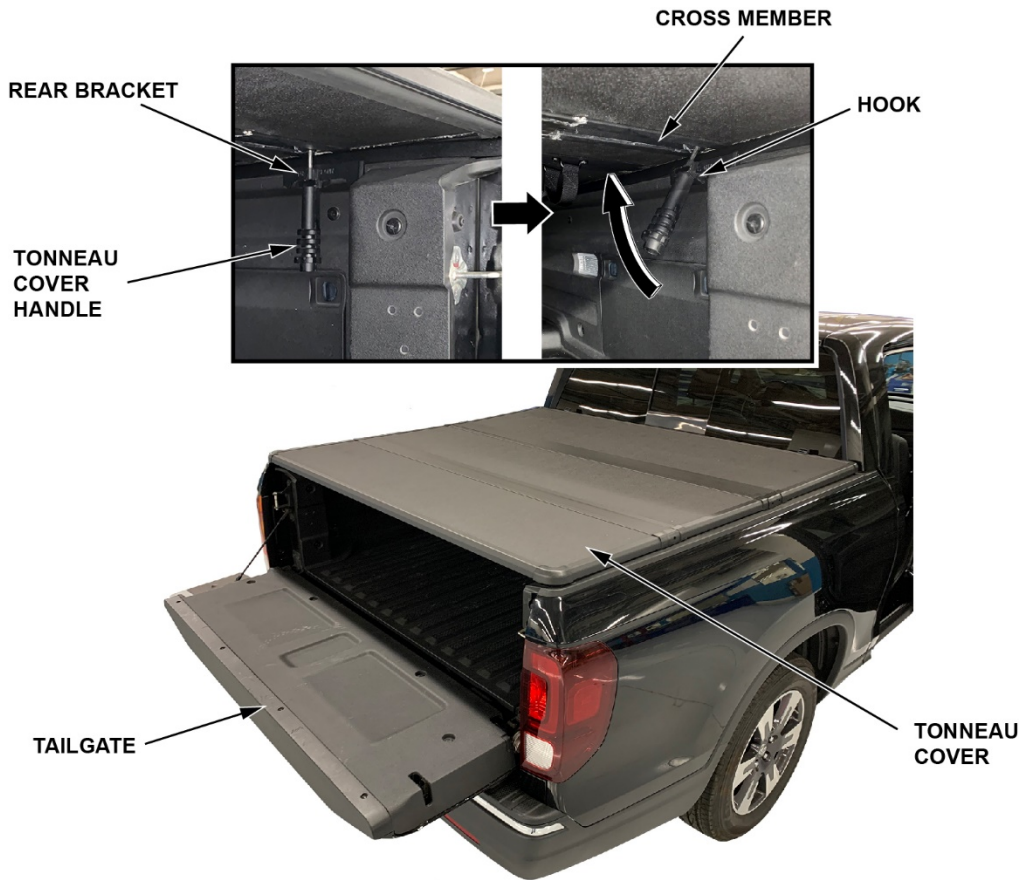

3. Fold the tonneau cover up toward the cabin (open position).

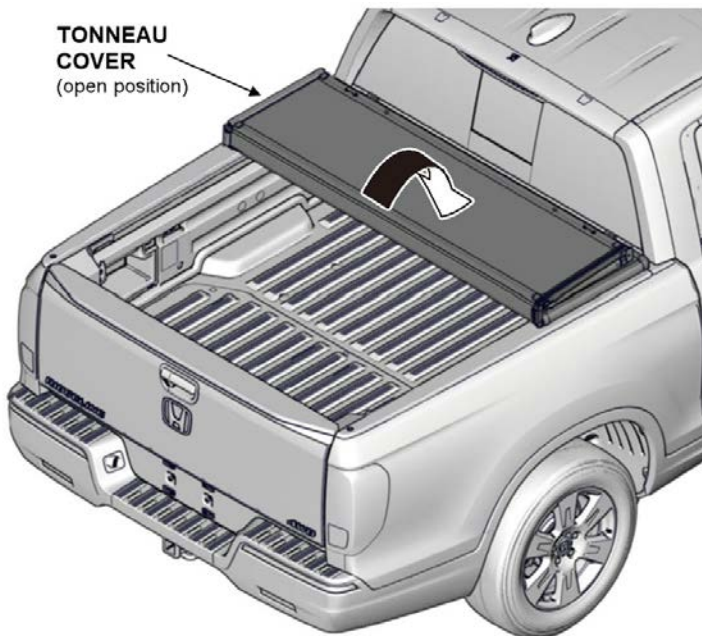

4. While the cover is in the open position, remove the D-rings and tethers straps from the center panel and throw them away. Retain the tapping screws.

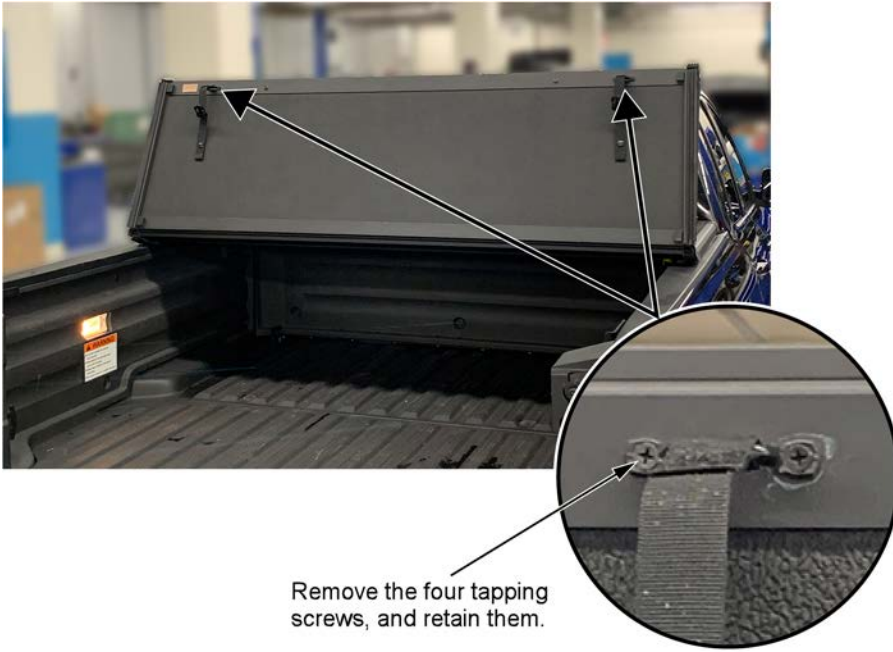

5. Using two of the tapping screws you just removed, install the template from the kit to where you removed the D-ring.

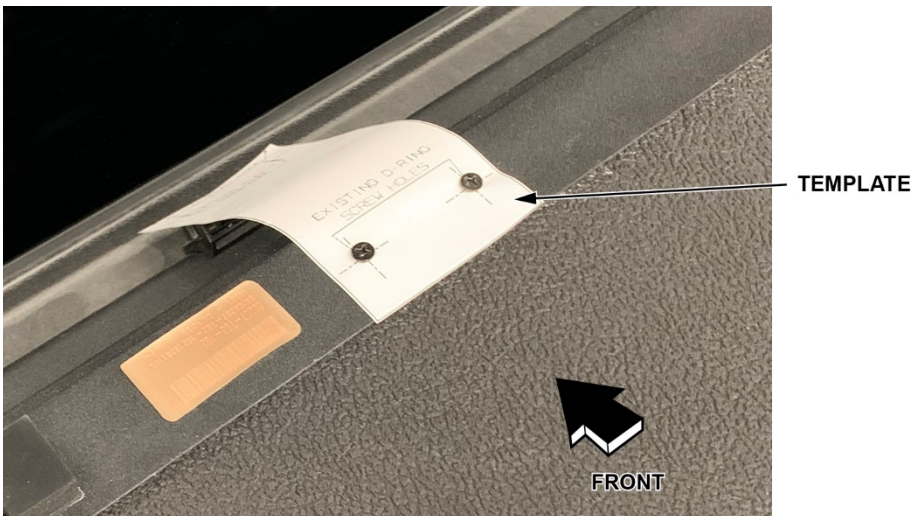

6. Unfold the tonneau cover so the rear panel is sitting above the center panel. Take the other end of the template, and line it up with the edge of the hinge as shown. Then secure the template with masking tape.



PANEL HINGE

Secure template with tape.

Line up template with panel edge.

How it should look after the step is complete.



7. Use a center punch tool to mark the hinge holes as shown on the template.

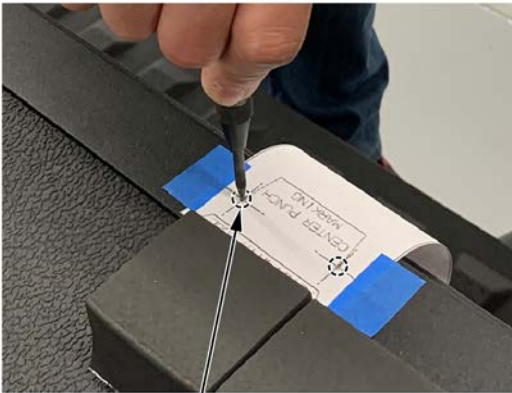

Mark using center punch.

8. Carefully remove the two screws and masking tape holding the template in place. Discard the two screws and masking tape, but keep the template. You will need it again.
9. Repeat steps 5 thru 7 on the other side of the panel using the same template and the remaining two tapping screws.

10. Use a 2.5 mm drill bit to drill holes on the four punch marks, then remove any burrs.

**NOTICE**

Use masking tape to serve as a drill stop at **5 mm**. If you drill too deep you can damage the hinge.

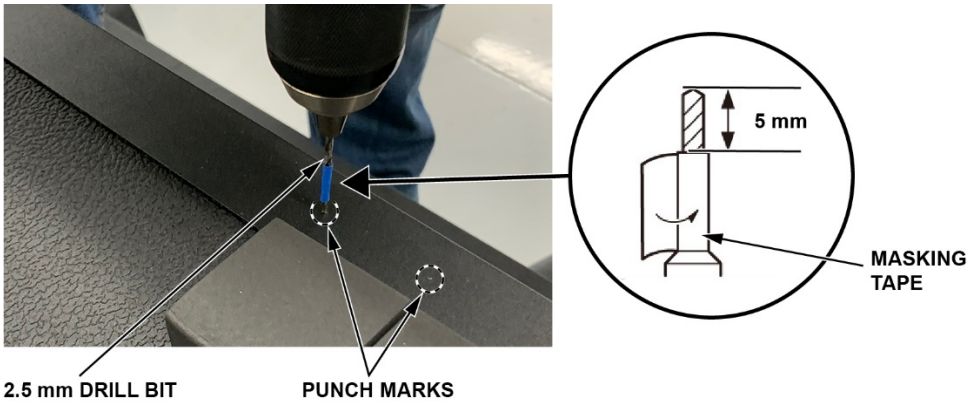

11. Install the new D-ring with the tether strap end to the rear panel using new tapping screws. Start the screws by hand, then torque them with the 1/4 inch drive torque wrench to **2.25 N·m (20 lb-in)**. Repeat this step on the other side (driver/passenger side).



12. Install the other new D-ring to the center panel using new tapping screws. Start the screws by hand, then torque them with the 1/4 inch drive torque wrench to **2.25 N·m (20 lb-in)**. Repeat this step on the other side (driver/passenger side).



13. Use isopropyl alcohol to thoroughly clean the surface of the rear panel where you will install the warning label. Make sure the alcohol is completely dry, then install the label as shown, and apply pressure to the entire surface of the label using a trim roller.

**NOTE**

Make sure the warning label's orientation is correct. The orange should be facing toward the front of the vehicle.

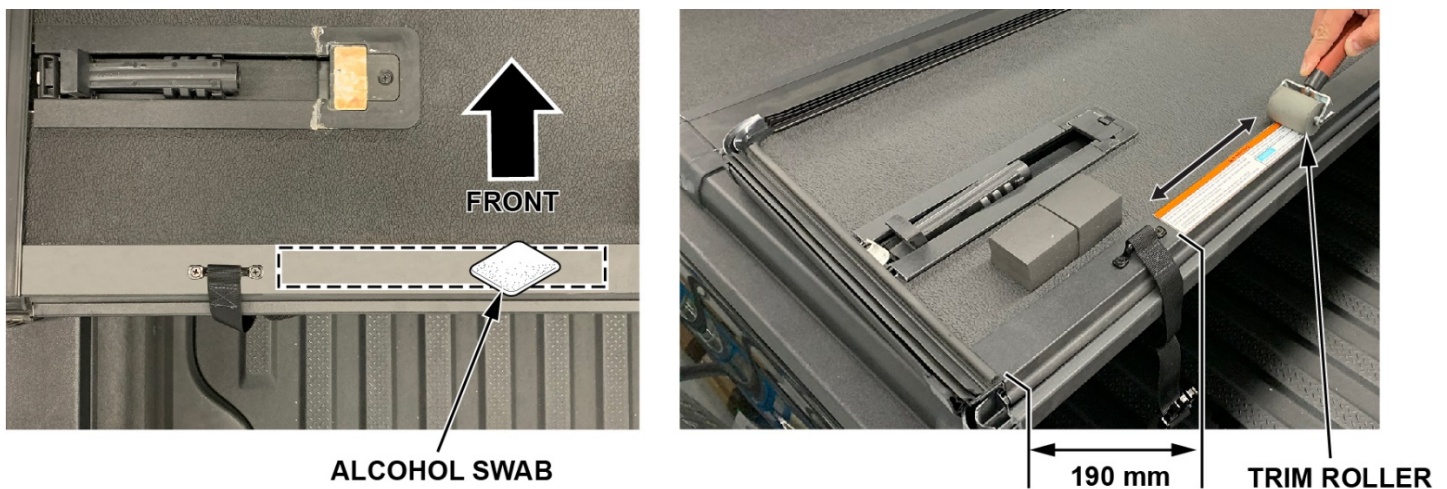

14. Fold the tonneau cover to the open position, and use isopropyl alcohol to thoroughly clean the surface of the center panel where you will install the warning label. Make sure the alcohol is completely dry, then install the label as shown and apply pressure to the entire surface of the label using a trim roller.

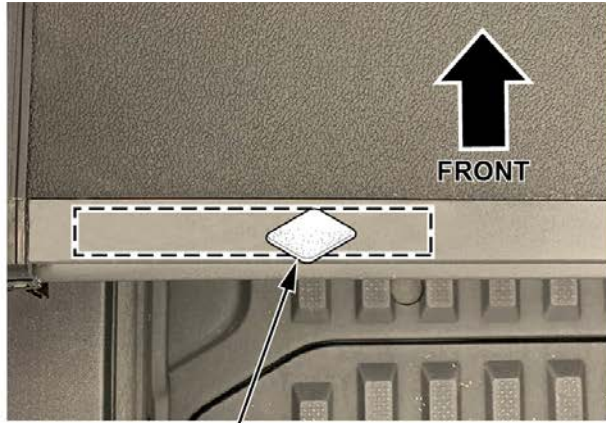

Clean the surface with isopropyl alcohol.



30 mm

TRIM ROLLER

15. Unfold the tonneau cover to the closed position. Pull down the tonneau cover handle, slide it toward the bed lining while pulling down, then attach the hook to the rear bracket. Repeat this step on the other side.

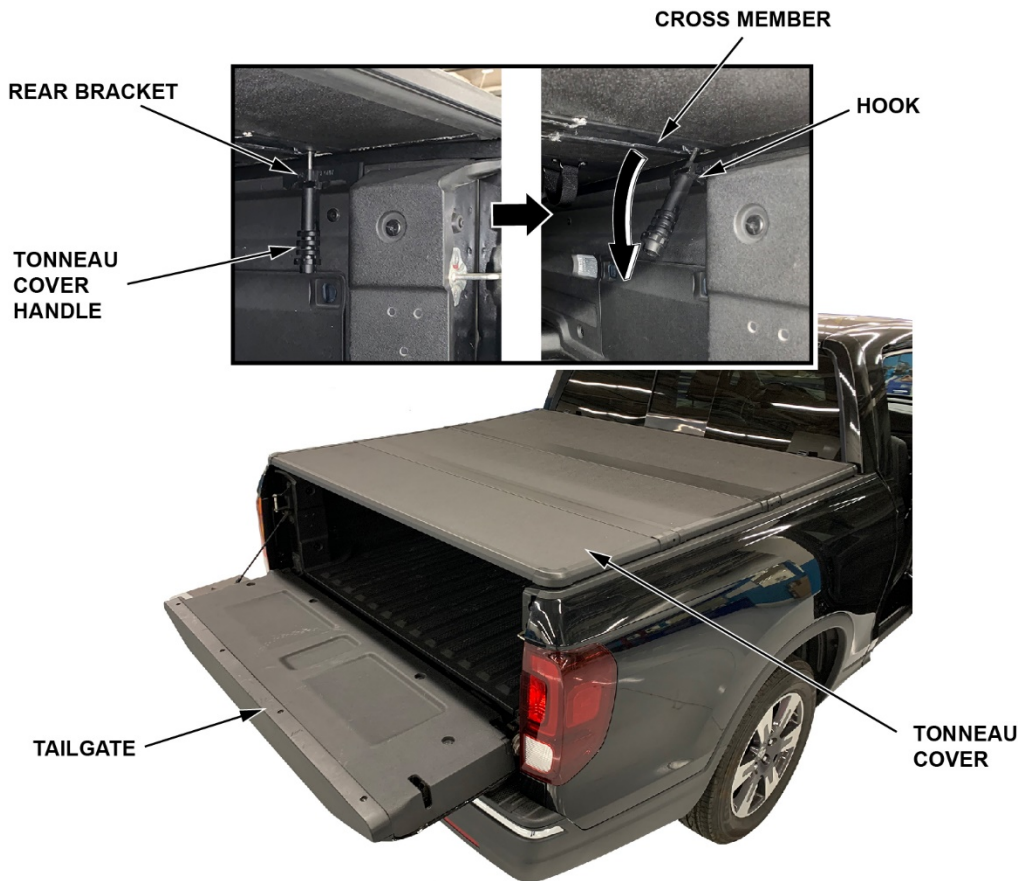

16. Close the tailgate.

17. Have the service advisor give the new accessory user's information manual from the kit to the customer.

END