

This document includes instructions for inspecting the lower rear pivot fasteners equipped on applicable Watson & Chalin ("W&C") SL2065 20,000-pound rated capacity steerable auxiliary lift axle suspensions systems subject to W&C Technical Bulletin Number W&C265 (SL2065 Pivot Fastener Notice).

Inspection of the required suspension components should take approximately 1 hour from start to finish. This includes the time for pulling the vehicle into the work area, ensuring safety, performing the inspection, and returning the vehicle to the lot.

The suspension images below show the location of the fasteners that must be inspected on both sides of the suspension. If either fastener fails inspection, replace both fasteners.

Front Driver's Side View of Suspension

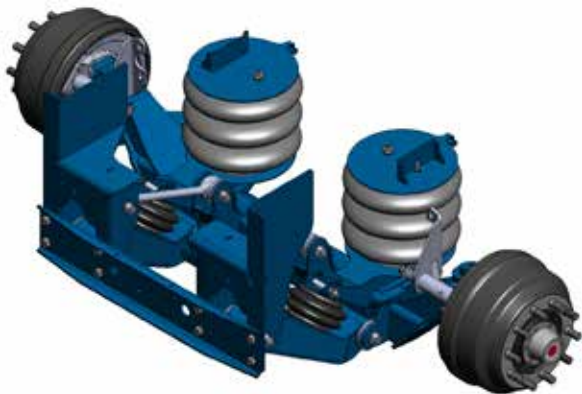

Front View of Suspension

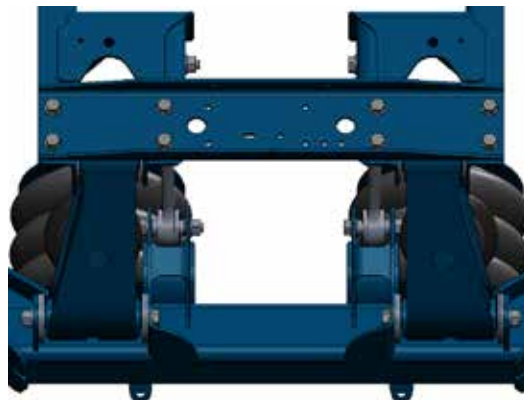

THE TOOLS REQUIRED ARE AS FOLLOWS:

1. Safety glasses
2. Ear plugs
3. Gloves
4. Torque wrench
5. 1-5/16-inch socket
6. 1-5/16-inch combination wrench
7. Wheel chocks
8. Vernier / dial / digital caliper

THE PIVOT FASTENER INSPECTION PROCESS IS AS FOLLOWS:

1. Verify all required tools are available.
2. Verify all required tools are free from damage or defects that would impair function.
3. Lay out all required tools such that they can be easily located.
4. Park the vehicle on a flat, level surface.
5. Engage the parking brake so that the vehicle may not roll.
6. Chock the vehicle's wheels so that the vehicle may not roll.
7. Verify the vehicle will be properly restrained from movement and safe to work on.
8. Lower the auxiliary lift axle so that the tires are in contact with the ground.
9. Depressurize the auxiliary lift axle air system. Depressurize the entire vehicle air system if required.
10. Verify system air pressure cannot be restored inadvertently while working on the vehicle.
11. Follow any additional vehicle manufacturer and / or dealership safety procedures and precautions to ensure the vehicle can be safely repaired and maintained.
12. Locate the lower rear pivot fasteners to be inspected on the suspension, as shown in the pictures above.
13. Inspect the inboard cap screw heads and ensure they appear tight and flush with their mating brackets. If the capscrew is not fully seated, skip steps 14 thru 16, and contact W&C to order Service Replacement Kit Part Number SRK2065WAR-001. Install the service replacement kit per W&C Technical Bulletin Number W&C264 (SL2065 Pivot Fastener Installation).
14. Secure the heads of the capscrews with a combination wrench and tighten the nuts to 400 lb-ft torque. **DO NOT TORQUE FROM THE HEAD OF THE CAPSCREW.**
15. Measure from the outboard end of the capscrews to the outboard face of the nuts. See images on how to measure capscrew extension. If the fasteners are tightened to the torque specified in step 14, have 0.350 inch or greater extension past the end of the nut and otherwise appear to be in good condition, then they can continue to be used and no replacement is necessary.
16. If either fastener has less than 0.350 inch extension past the end of the nut, contact W&C to order Service Replacement Kit Part Number SRK2065WAR-001. Install the service replacement kit per W&C Technical Bulletin Number W&C264 (SL2065 Pivot Fastener Installation).
17. Re-pressurize the vehicle's air system.
18. Cycle the auxiliary suspension.
19. Return vehicle to lot.

Measuring Capscrew Extension



Measuring Capscrew Extension (Detail)



Insufficient Thread Extension



Sufficient Thread Extension



If you have any questions, contact W&C Customer Service:

Watson & Chalin Manufacturing, Inc.
725 E. University Dr.
McKinney, TX 75069
Phone: 972-838-1266
Email: wc-customerservice@watsonsuspensions.com

*Actual product performance may vary depending upon vehicle configuration, operation, service and other factors.
All applications must comply with applicable specifications from Watson & Chalin and the respective vehicle manufacturer.
Contact Watson & Chalin for additional details regarding specifications, applications, capacities, and operation, service and maintenance instructions.*

Contact Watson & Chalin at 972.547.6020 for additional information.



Watson & Chalin
725 E. University Drive, McKinney, Texas 75069
972.547.6020 • 800.445.0736 • Fax 972.542.0097
www.watsonsuspensions.com

