

This document includes instructions for the installation of Watson & Chalin ("W&C") Service Kit Part Number SRK2065WAR-001 for replacement, on an as-needed basis, of the lower rear pivot fasteners equipped on W&C SL2065 20,000 pound rated capacity steerable auxiliary lift axle suspensions systems. Refer to W&C Technical Bulletin No. W&C263 (SL2065 Pivot Fastener Inspection) with instructions for inspecting such fasteners. Both fasteners should be replaced if either fastener is found to have insufficient protrusion past the end of the nut.

Installation of service kit Part Number SRK2065WAR-001 should take no more than 1.5 hours from start to finish. This includes time for pulling the vehicle into the work area, performing the initial inspection per W&C Technical Bulletin Number W&C263 (SL2065 Pivot Fastener Inspection), performing the installation, testing the suspension and returning the vehicle to the lot.

Service Kit Part Number SRK2065WAR-001 includes the following replacement parts:

### CONTENTS: SRK2065WAR-001

PART #	DESCRIPTION	QTY
11222-02	WASHER FLAT, 0.91X4.25X0.25	8
17010	WASHER FLAT, 0.88X1.50X0.13	4
19801-10	NUT LOCK 7/8-9 GRC, ZINC FINISH	2
FAA088120000A00	CSCRW, 0.875, 12.000 LG, HEX, UNC, GR8, PL	2

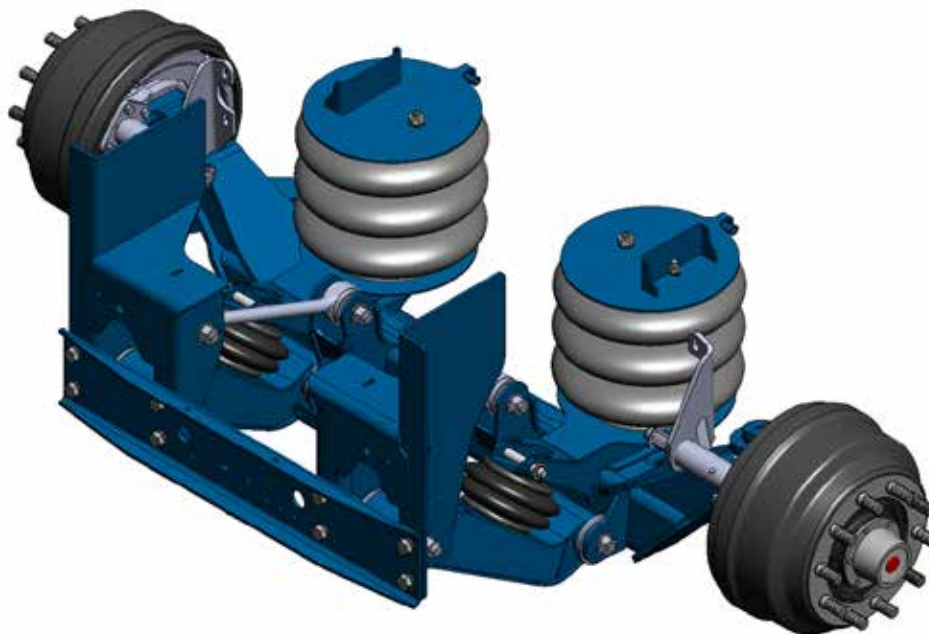

### THE TOOLS REQUIRED ARE AS FOLLOWS:

1. Safety glasses
2. Ear plugs
3. Face shield
4. Gloves
5. Impact wrench
6. Torque wrench
7. Extensions and drive swivel as necessary
8. 1-5/16-inch socket
9. 1-5/16-inch combination wrench
10. Grinder and cutoff wheels
11. Pry bars
12. Punches
13. Rubber mallet or hammer
14. Floor jack
15. Lifting straps
16. Wheel chocks
17. Compressed air source

### THE PIVOT FASTENER INSTALLATION PROCESS IS PERFORMED AS FOLLOWS:

1. Verify all required parts were received in the service repair kit.
2. Verify all required parts are free from damage that would impair function.
3. Verify that the threads of the fasteners are clean and dry.
4. Lay out all required replacement parts such that they can be easily located during reassembly.
5. Verify all required tools are available.
6. Verify all required tools are free from damage that would impair function.
7. Lay out all required tools such that they can be easily located.
8. Park the vehicle on a flat, level surface.
9. Engage the parking brake so that the vehicle may not roll.
10. Chock the vehicle's wheels so that the vehicle may not roll.
11. Verify the vehicle will be properly restrained from movement and safe to work on.
12. Lower the auxiliary lift axle so that the tires are in contact with the ground.
13. Depressurize the auxiliary lift axle air system. De-pressurize the entire vehicle air system if required.
14. Verify system air pressure cannot be restored inadvertently while working on the vehicle.
15. Follow any additional vehicle manufacturer and/or dealership safety procedures and precautions to ensure the vehicle can be safely repaired and maintained.

16. Support the auxiliary lift axle with adjustable supports such as jacks, stands, or straps so that it does not roll or move when the control arm fasteners are removed.
17. From this point forward, work on only one side of the vehicle at a time.

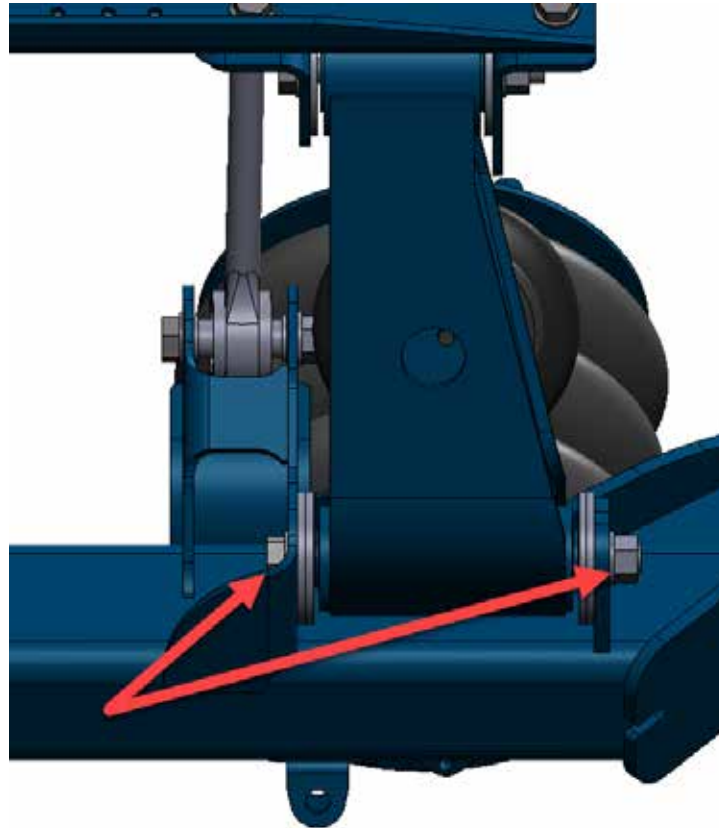

18. Remove the axle-side fasteners:
  - a. Make note of the lower control arm spacer washer locations. These are the large diameter washers inside of the axle flanges. If required, mark the locations or take photographs to reference during re-installation. **NOTE THAT WASHER LOCATIONS MAY DIFFER FROM THE ABOVE PICTURE.** Spacer washers may be left in and reused if they are free from damage.
  - b. Use 1-5/16-inch wrenches and/or sockets to remove the nuts.
  - c. If required, use a grinder and cutoff wheel to remove stuck fasteners. Take care not to damage the axle flange, axle tube, or any other vehicle components when using the grinder.
  - d. Secure the control arm with a jack stand so it does not fall, and knock out the capscrew using punches and a hammer. **USE CAUTION, AS CONTROL ARM MAY SHIFT WHEN THE FASTENER IS REMOVED.**
19. Install the replacement fasteners:
  - a. If required, place a floor jack or other lifting device under the lower control arm, then raise it into the axle.
  - b. Install the lower control arm spacer washers. An alignment or center punch inserted from the outboard side may be used to hold them in place until the capscrew is inserted. For correct washer locations, reference notes taken in Step 18a.

- c. Install the lower control arm pivot capscrew, washers, and nut, but do not tighten.
  - d. Use 1-5/16-inch wrenches and / or sockets to snug the lower pivot fastener. Confirm fastener is fully engaged with the joint.
  - e. Secure the heads of the capscrews with a combination wrench and tighten the nuts to 400 lb-ft torque. **DO NOT TORQUE FROM HEAD OF CAP SCREW.**
20. Repeat steps 18 and 19 for the opposite side of the vehicle.
  21. Re-pressurize the vehicle's air system.
  22. Cycle the auxiliary suspension.
  23. Return vehicle to lot.

If you have any questions, contact W&C Customer Service:

Watson & Chalin Manufacturing, Inc.  
725 E. University Dr.  
McKinney, TX 75069  
Phone: 972-838-1266  
Email: [wc-customerservice@watsonsuspensions.com](mailto:wc-customerservice@watsonsuspensions.com)

*Actual product performance may vary depending upon vehicle configuration, operation, service and other factors.  
All applications must comply with applicable specifications from Watson & Chalin and the respective vehicle manufacturer.  
Contact Watson & Chalin for additional details regarding specifications, applications, capacities, and operation, service and maintenance instructions.*

**Contact Watson & Chalin at 972.547.6020 for additional information.**



**Watson & Chalin**  
725 E. University Drive, McKinney, Texas 75069  
972.547.6020 • 800.445.0736 • Fax 972.542.0097  
[www.watsonsuspensions.com](http://www.watsonsuspensions.com)



W&C264 09-20 *Watson and Chalin is a brand of Hendrickson*

© 2020 Watson & Chalin Manufacturing Inc. All Rights Reserved. All trademarks shown are owned by Watson & Chalin Manufacturing Inc., or one of its affiliates, in one or more countries.  
Information contained in this literature was accurate at the time of publication. Product changes may have been made after the copyright date that are not reflected.

Printed in United States of America