

Spicer® Tandem Drive Axles



SPICER®

Drivetrain Products

Service Manual

AXSM0057

September 2013

D170 Series

D190 Series

D590 Series

Table of Contents

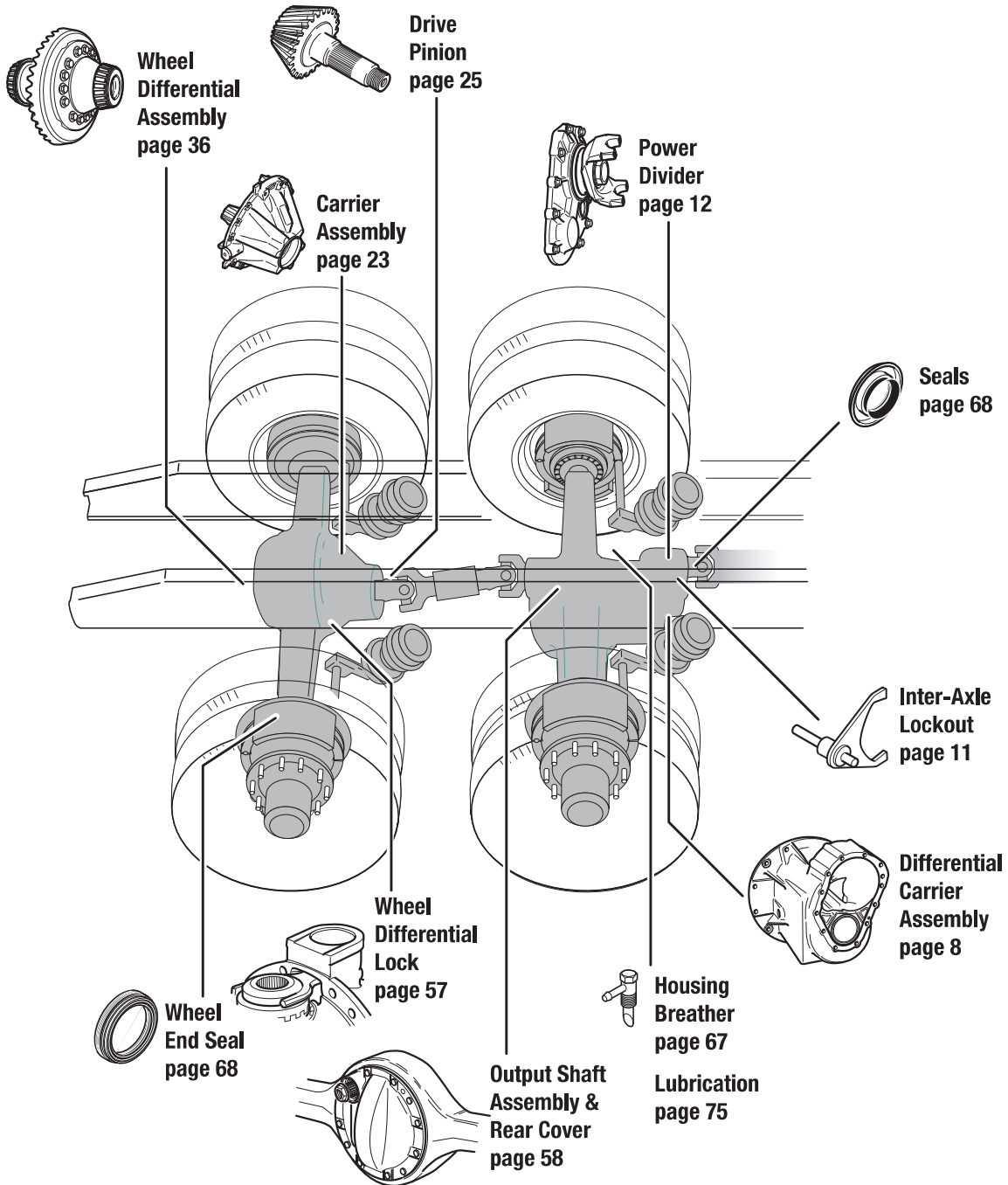

Housing and Output Shaft Assembly - Parts Exploded View

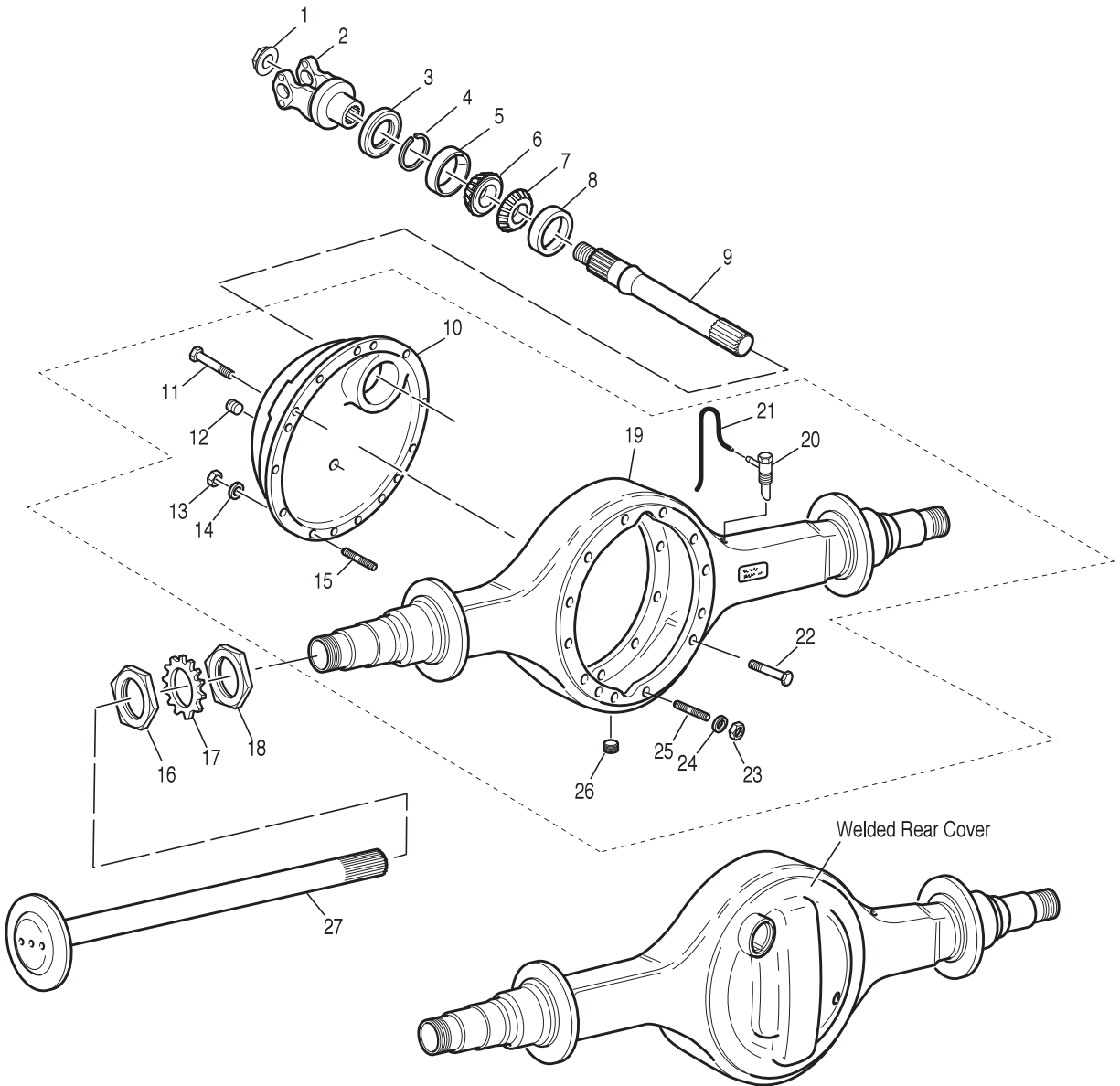

- 1 - Output shaft nut
- 2 - Output yoke
- 3 - Output seal
- 4 - Snap ring
- 5 - Outer bearing cup
- 6 - Outer bearing cone
- 7 - Inner bearing cone
- 8 - Inner bearing cup
- 9 - Output shaft

- 10 - Rear cover
- 11 - Rear cover capscrew
- 12 - Fill plug
- 13 - Rear cover nut
- 14 - Washer
- 15 - Stud
- 16 - Spindle nut - Outer
- 17 - Locking ring
- 18 - Spindle nut - Inner

- 19 - Axle housing
- 20 - Breather
- 21 - Breather hose
- 22 - Carrier capscrew
- 23 - Nut
- 24 - Washer
- 25 - Stud
- 26 - Drain plug
- 27 - Axle shaft

Remove Output Shaft Assembly

Note: For forward axle rear covers that are removable the output shaft may be removed when the cover is in or out of the axle assembly.

1. Disconnect the inter-axle driveline at the forward axle rear cover position.
2. Remove yoke nut (shoulder nut).
3. Remove yoke from output shaft using appropriate tool.

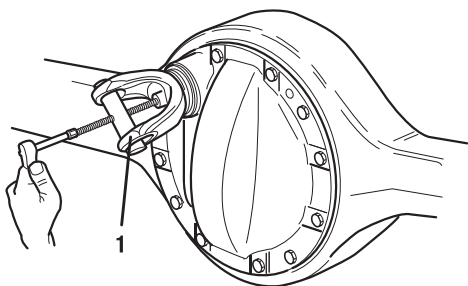

1 - Yoke Puller Tool

TIP: A yoke puller tool may be made from the center section of most gear puller tools, or may be purchased from your tool distributor.

4. Remove oil seal.
5. Remove snap ring.

6. Remove output shaft and outer bearing cup as an assembly.

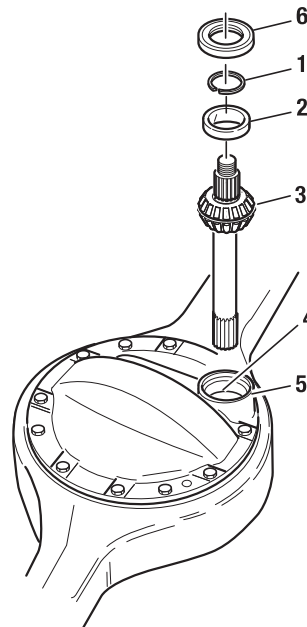

1 - Snap Ring
 2 - Outer Bearing Cup
 3 - Output Shaft Assembly
 4 - Inner Bearing Cup
 5 - Rear Cover Assembly
 6 - Output Seal

TIP: It may be helpful to loosely reinstall the yoke and shoulder nut giving the technician more of an area to grip when removing the output shaft.

7. Remove the inner bearing cup from rear cover assembly. This may be removed from inside the axle housing when the carrier is removed, or by removal of the forward axle rear cover.

Output Shaft Assembly & Rear Cover

8. Remove both inner and outer bearing from output shaft.

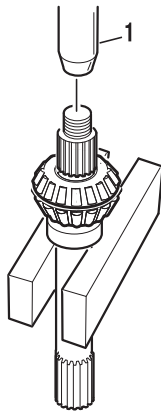

1 - Press

9. Remove output shaft inner bearing cup.

Note: Components such as the inter-axle driveline, yoke, oil seal and output shaft assembly should have been removed according to normal service procedures. Removing the differential assembly from the axle housing is not necessary, but would ease the removal process of the inner bearing cup from the cover bore.

- a. Using a bearing puller tool, remove the inner bearing cup.
- b. Visually inspect the inner-machined bore surface of the welded-on cover for nicks and burrs. Repair if necessary.

Overhaul and Assemble Output Shaft Assembly

Note: Lubricate the parts with gear lube during assembly.

1. The output shaft bearings are assembled with both bearing cones back to back. Use a press and a sleeve to install one bearing at a time.



To prevent bearing damage, use a suitable sleeve that only contacts the bearing race.

2. Apply pressure until the inner bearing cone touches the shoulder of the output shaft.
3. Apply pressure until the back of the outer bearing cone touches the back of the inner bearing.

Note: Axle housings with welded-on covers procured through service will include the inner bearing cup as part of the “service” axle housing assembly. Go to Step 6 if the inner cup has already been installed.

4. Lightly coat the output bore of the axle housing cover with a 9.5 mm (.38”) wide application of Loctite 680 where the bore contacts the inner bearing cup. Do not apply Loctite outside of this area—to the bearing rollers or outboard of the inner cup bore. Improper application of the Loctite could lock the rollers or cause excessive pre-load.



Add Loctite adhesive to the inner bearing surface of the housing and NOT to the bearing race itself. If added to the race, excessive adhesive could get on the surface of the outer bearing race journal during installation and cure the outer cap in place with excessive pre-load.

5. Using a sleeve and driver (hammer), install the inner bearing cup.
6. Put the output shaft and bearing assembly into the axle housing assembly.

7. Using a sleeve and driver (hammer), install the outer bearing cup into the housing assembly over the output shaft bearing cone.
8. Using snap ring pliers, install the snap ring that fastens the outer bearing cup into the welded-on cover assembly.
9. Check the endplay of the output shaft. New assemblies should measure 0.001” to 0.045” (0.03 to 1.143 mm).

Note: Use the bearing cup driver to insure seating of snap ring after installation with snap ring pliers.

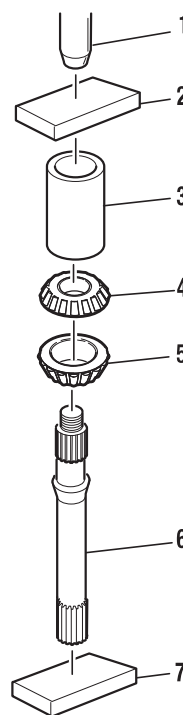

- 1 - Press
- 2 - Plate
- 3 - Sleeve
- 4 - Press Bearing on Second
- 5 - Press Bearing on First
- 6 - Output Shaft
- 7 - Plate

Output Shaft Assembly & Rear Cover

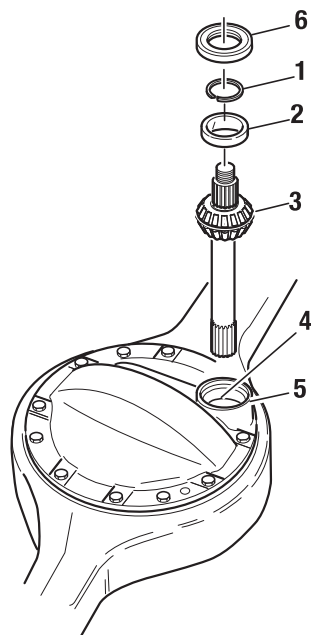

- 1 - Snap Ring
- 2 - Bearing Cup
- 3 - Output Shaft Assembly
- 4 - Inner Bearing Cup
- 5 - Rear Cover Assembly
- 6 - Output Seal

10. Bolted rear cover only: If removed, install cover and fasten with nuts, capscrews and lock washers. Tighten to proper torque specifications. See the Torque Chart.

Note: Use Spicer approved RTV compound on axle housing mating surface. Completely remove all old gasket material prior to applying new material. Compound will set in 20 minutes. Install axle housing cover and output shaft assembly before compound sets or reapply.

11. Install the output seal.

12. Install output yoke.

Note: Use of a torque multiplier is recommended.

TIP: If you can't get the correct torque on yoke nut, try torquing the nut with the truck wheels on the ground and with the axle shafts installed.

13. Install axle shafts and axle stud nuts (If used, also install lock washers and taper dowels).

14. Connect inter-axle driveline. Make sure driveline is properly phased. Lubricate u-joints.

15. Add axle lubricant. Fill to bottom of filler hole.

▲ IMPORTANT

When axle has been disassembled or housing, axle shafts or wheel equipment replaced, check axle assembly for proper differential actions before operating vehicle. Wheels must rotate freely and independently.

Road test vehicle to bring axle lubricant up to temperature. Recheck joints, drain and fill plugs for leakage. Retighten as necessary.

Measure

Correct endplay for a new assembly is 0.001" to 0.045" [0.03 to 1.143 mm]. The maximum endplay for a used assembly is no more than 0.045" (1.143 mm). If endplay is incorrect, contact Dana.

1. Install oil seal.
2. Install yoke.
3. Install yoke nut. One of the following options may be utilized:
 - a. Install a new nut with the pre-applied thread adhesive compound. Tighten the nut to the specified torque. See the Torque Chart.
 - b. If a new nut with pre-applied thread adhesive compound is unavailable, apply Loctite 277 or 271 (available in 0.5 ml tube—P/N 129293) to the nut along two threads, for at least two flats (120°) of the nut midway through the thickness (see illustration). Tighten the nut to the specified torque. See the Torque Chart.

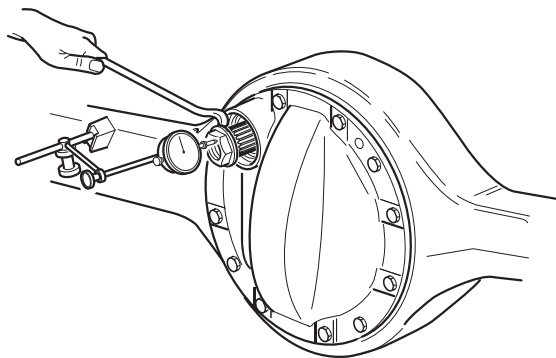

Replace Seal

Spicer strongly recommends using seal drivers when installing new seals. Use the proper driver to make sure that the seal is square and installed to the proper depth.

CAUTION

Oil seals can be easily damaged prior to installation. Use care when handling the new seal to prevent damage or contamination. Leave the seal in its package until installation. On new yokes, leave the protector on the yoke until it is installed on the shaft to prevent damage or contamination.

1. Inspect axle endplay at the yoke (see page 10). Service if beyond specified limit.
2. Remove the old yoke using appropriate tool. A yoke puller tool may be made from the center section of most gear puller tools, or may be purchased from your local tool distributor.

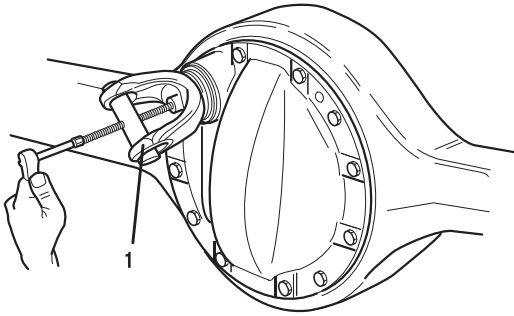

1 - Yoke Puller Tool

3. Remove seal. Use care when removing the old seal to prevent damage to the housing seal bore.
4. Inspect the seal bore area for any damage (nicks, gouges, corrosion). Carefully remove any slight damage with a crocus cloth. Clean the bore area to remove any loose debris.

CAUTION

Do not use any silicone or permatex-type bore sealant with this seal.

5. Remove the new seal from its package and install with the proper driver:
 - D - Input Driver - 210749
 - D - Input Insert - 131472
 - D - Output Driver - 131471
 - R - Pinion Driver - 210749
 - R - Pinion Insert - 131472

WARNING

Due to the resiliency of the plastic driver, hammer rebound may occur when the seal is seated. Keep clear of the hammer rebound path!

6. Handle the seal by its outside diameter avoiding any contact with the seal lips. During installation, use the proper driver to make sure that the seal is mounted properly.
7. Use a rubber mallet to drive the seal tool in until the flange bottoms on the housing cover bore face. The flange will locate the seal at the proper depth.

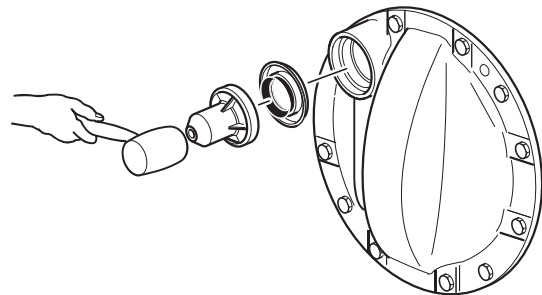

Guidelines for Reusing Yoke

 CAUTION

Do not use the yoke if it has any damage on the seal surface (nicks or scratches).

The surface of the yoke and the lips of the seal form a critical interface which retains the axle's lubricant while sealing the axle from outside contaminants. The condition of the yoke hub's surface is a very important factor in determining seal life.

Carefully inspect the seal surface area of the yoke hub for signs of wear and damage. Do not reuse the yoke if there is noticeable wear, such as heavy grooving, beyond normal polishing from the seal lips.

Note: Do not rework the yoke with abrasives such as emery paper or crocus cloth. Clean the surface of the yoke as necessary using chemical cleaners. Remove all trace of the chemicals from the yoke after cleaning.

 CAUTION

Do not use wear sleeves. Wear sleeves increase the yoke hub surface diameter and cause premature seal wear and repeat seal failure.

Fastener Torque Specifications

Location	Size	Lbs. Ft.	N•m
POWER DIVIDER			
Input Cage Locking Bolt	M8 x 1.0 x 30	13 ± 17	17 ± 23
Input Cage Locking Stud	M12 x 1.75	15 ± 20	20 ± 27
Locking Stud Jam Nut	M12 x 1.75	60 ± 65	81 ± 88
IAD Shift End Cap	2.375 - 16 UN-2A	65 ± 10	85 ± 15
Power Divider Cover Capscrews	M14 x 1.5 x 45	175 ± 10	235 ± 10
Input Shaft Nut	M48 x 1.5	900 ± 100	1220 ± 135
WHEEL DIFFERENTIAL AND GEARING			
Front Pinion Helical Nut	M48 x 1.5	900 ± 100	1220 ± 135
Output Shaft Nut	M42 x 1.5	900 ± 100	1220 ± 135
Rear Pinion Nut	M48 x 1.5	900 ± 100	1220 ± 135
Ring Gear, Diff. Case Bolts	M20 x 1.5 x 55	500 ± 25	675 ± 30
CARRIER			
Carrier Diff. Bearing Cap	M18 x 1.5 x 85	265 ± 15	360 ± 20
Carrier to Housing Capscrews	M16 x 1.5 x 85	250 ± 15	335 ± 20
	M16 x 1.5 x 55	250 ± 15	335 ± 20
Carrier to Housing Nuts	M16 x 1.5	250 ± 15	335 ± 20
Pilot Bearing Web	M16 x 1.5 x 70	210 ± 10	285 ± 15
Differential Lock Switch	M14 x 1.5	10 ± 1	15 ± 3
Differential Lock End Cap	2.375 - 16 UN-2A	65 ± 10	85 ± 15
HOUSING			
Rear Cover Capscrews	M16 x 1.5 x 70	250 ± 15	335 ± 20
	M16 x 1.5 x 55	250 ± 15	335 ± 20
Rear Cover Nuts	M16 x 1.5	250 ± 15	335 ± 20
Magnetic Plug (Fill)	1 x 11.5 NPTF	50 ± 5	72 ± 5
Drain Plug	0.750 - 14 NPTF	50 ± 5	72 ± 5
Housing Breather	0.375 - 18 NPTF	20 - 26	27 - 35
Temperature Sending Plug	0.500 - 20 NPTF	50 ± 5	72 ± 5
Axle Shaft to Wheel Hub Nut	0.625 - 18	180 ± 10	245 ± 15
	0.750 - 16	315 ± 30	425 ± 40
Wheel Diff. Lock Caps	2.37-16UN 2A	65 ± 10	85 ± 15

For specifying or service assistance, call 1-877-777-5360 or visit our website at www.dana.com

Dana Commercial Vehicle Products Group

3939 Technology Drive
Maumee, Ohio, USA 43537

www.dana.com



SPICER[®]

Drivetrain Products