



**Emer™ PRD Replacement for Gillig CNG
Fuel Systems with Type 3 Cylinders and
Electric Solenoid Cylinder Valves
ENP-741 REV B
August 5, 2020**

1. Introduction

Agility Fuel Solutions LLC (Agility®) has determined that pressure relief devices (PRDs) manufactured by Emer™ may fail to operate as designed. This issue has been reported to the National Highway Traffic and Safety Administration (NHSTSA Recall No. 20E-019). Impacted parts include Emer™ cylinder plug PRD, p/n PRD2322T-001 (Agility® p/n 10301046), and Emer cylinder valve PRD, p/n PRD2102T (no equivalent Agility® p/n) used in Agility® compressed natural gas (CNG) fuel systems produced from October 6, 2016, to April 1, 2020.

PRDs are essential for safe vehicle operation and must be replaced if non-compliant. Agility® personnel have identified fuel system top level part numbers supplied for Gillig buses containing recalled Emer™ PRDs as original equipment manufacturer (OEM) equipment.

Agility® created this instructional document to guide trained CNG fuel system service technicians in the removal, replacement, and reporting of affected Emer™ PRDs.

1.1. Warning Messages and Symbols used in this document



Will cause death or severe injuries if procedures are not followed.



Could cause death or severe injuries if procedures are not followed.



Could cause minor or moderate injuries if procedures are not followed.



Practices not related to physical injury. Includes procedures to prevent vehicle damage as well as hints to help an operation or procedure go smoothly.



Critical Characteristic

Procedure directly affects safety of vehicle users, people nearby and maintenance personnel, or regulatory compliance.



Manufacturing Characteristic

- *A product feature solely used to improve manufacturability or maintain process control .*
- *A process parameter or step that has a significant effect on achieving a Critical Characteristic or Significant Characteristic, or maintaining material identification/traceability.*

2. Affected Units

Agility® top level system part numbers as follows:

25513000 - Roof Mount, 144 DGE, 2036 L, 8 Tanks, 3 Pin Harness, Gillig

25515000 - Roof Mount, 126 DGE, 1657 L, 8 Tanks, 3 Pin Harness, Gillig

25517000 - Roof Mount, 126 DGE, 1657 L, 8 Tanks, 3 Pin Harness, Gillig

3. Tools and Supplies Required

Fall protection equipment	Safety glasses
Safety ladder	Defueling hose with nozzle**
NGV1 fuel receptacle adapter*	Microfiber towels
Water pump plier or Vise-Grip® locking plier or equivalent	Socket and combination wrenches
	Torque wrench†
Loctite® 276 thread sealer	Loctite® 577 thread sealer
Parker® O-lube O-ring lubricant or equivalent	Swagelok® Snoop® leak detection solution or equivalent
Torque Seal marker	Agility® reporting form FT.0321
Permanent marker	Flashlight
Blue paint marker	Camera / phone camera
Zip lock bag <i>(Supplied by Agility® with bulk replacement PRD shipment—use for PRD return)</i>	15/16-in. angled open end wrench (Tekton® p/n WAE83024 or equivalent) OR Modified 1/2-in. drive 24mm deep socket and 1/2-in. drive ratchet†

*may be required for defueling on some FMMs

**If not provided at CNG fueling facility

†If modified 24mm socket is unavailable, a 15/16-in. crow foot must be used with torque wrench.

3.1. PRD retrofit kits

NOTICE

Before beginning work, verify proper quantity of correct Agility® PRDs is on hand.

Agility® PRD part number and corresponding fuel system quantities are as follows:

Agility® fuel system p/n	Emer™ plug PRD p/n PRD2322T-001 Agility® p/n 10301046 QTY	Emer™ valve PRD p/n PRD2102T QTY
25513000	8	8
25515000	8	8
25517000	8	8

4. Parts Location Identification

Refer to the appropriate fuel system illustration to locate the affected Emer™ PRDs in fuel system plumbing. *Figures 1 and 2*

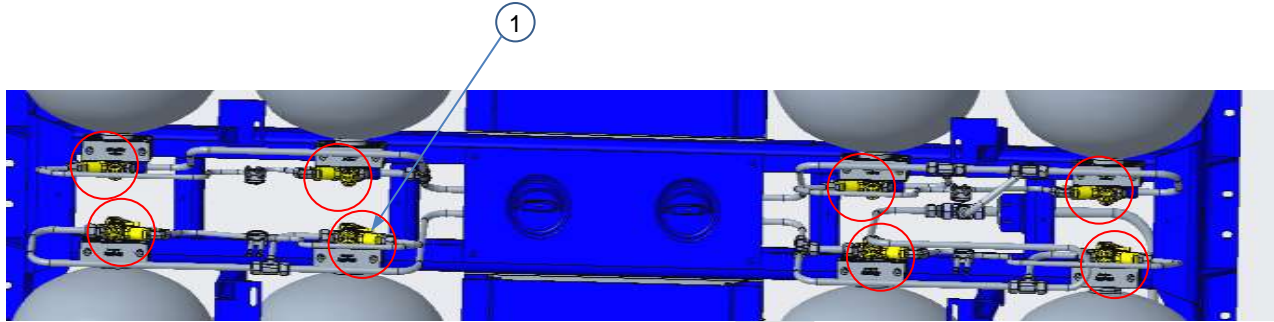

Figure 1.
Emer™ cylinder valves (yellow) equipped with valve PRDs (1)..

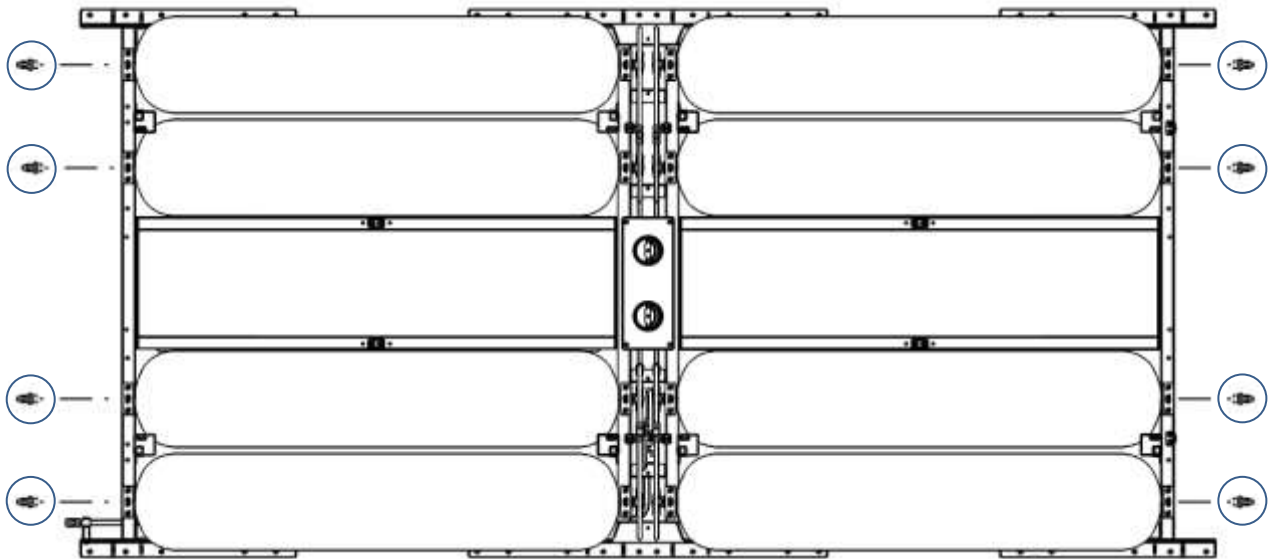
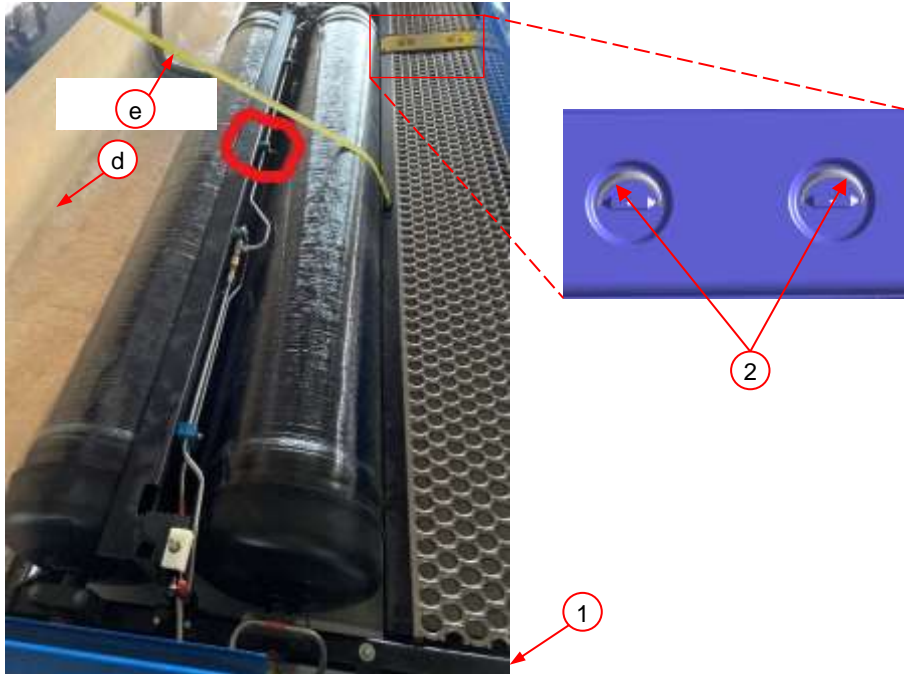

Figure 2.
Emer™ cylinder plug end PRDs (circled) in fuel system plumbing.
NOTE: PRD vent tubes and elbow fittings not shown for clarity.

5. Corrective Action / Procedure

5.1. Preliminary Safety Preparation

1	⚠ WARNING Set parking brake and secure vehicle with wheel chocks (<i>not shown</i>).		2	⚠ WARNING Attach a lock and tag (<i>not shown</i>) to block vehicle ignition.	
WHAT	Worker safety.		WHAT	Prevent vehicle start during repair procedure.	
WHY			WHY		
3	⚠ WARNING Secure a safety ladder in either of the following locations: A. Inside bus hatch opening B. Rear of bus exterior				
WHAT	Worker safety.				
WHY					

4	<p>1. Open fuel system roof pod doors (d).</p> <p>⚠ WARNING</p> <p>2. Secure fall protection equipment (<i>not shown</i>) to facility fall protection apparatus or to fall restraint lanyard attachment points (2).</p> <p>⚠ WARNING</p> <p>3. Secure doors open with door retention strap (e). Refer to vehicle OEM instructions.</p> <p>⚠ WARNING</p> <p>4. Always reattach fall PPE when resuming work on the roof mount portion of the fuel system.</p>	
WHAT		
WHY	Worker safety.	

5.2. Prior to defueling

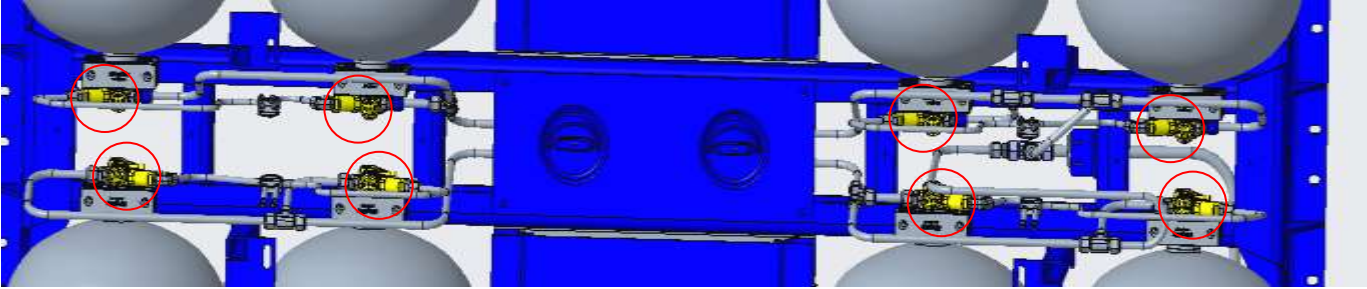
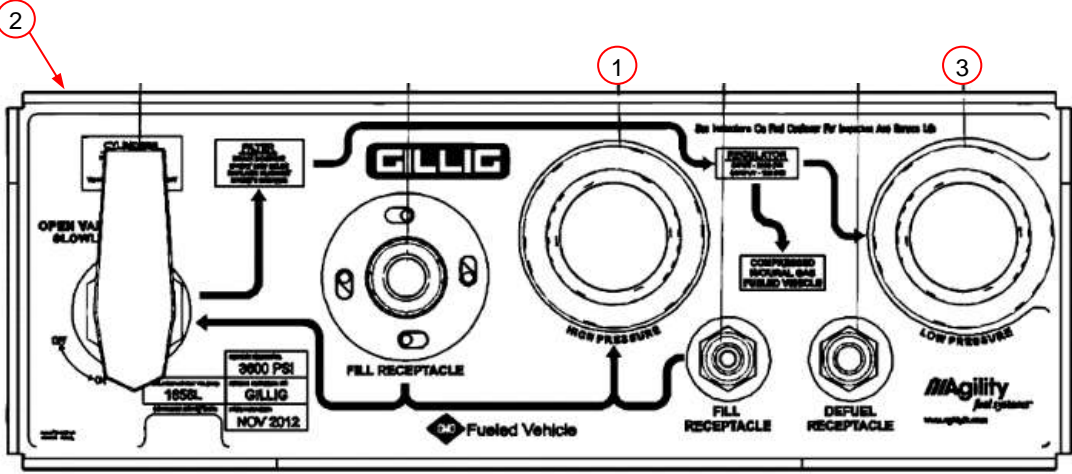
1	<p>⚠ WARNING</p> <p>Verify all eight cylinder valves (circled) are open.</p>	
WHAT		
2	<p>Check high pressure gauge (1) and low pressure gauge (3) on fuel management module (FMM) (2) to verify amount of fuel in the system.</p> <p>IMPORTANT: If vehicle has no fuel onboard, proceed to Step 4.</p>	
WHY		

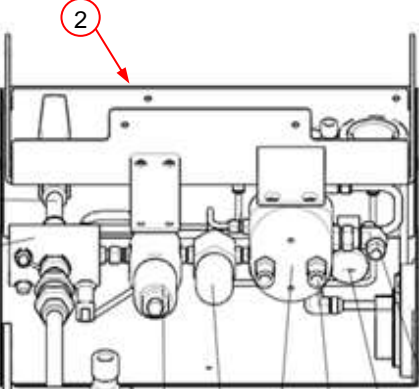
<p>3</p> <p>WHAT</p>	<p><i>If not already defueled:</i> Defuel bus according to local facility regulations and procedure. <i>If required:</i> use defuel hose kit.</p> <p>⚠ WARNING <i>Only trained CNG fuel systems technicians may perform system defueling.</i></p> <p>NOTICE <i>If required:</i> Use appropriate defuel nozzle adapter.</p>		<p>4</p> <p>WHAT</p>	<p>⚠ WARNING Relieve any remaining system pressure by slowly opening the FMM (2) bleed valve (<i>not visible</i>). <i>NOTE: FMM rear view shown.</i></p>	
<p>WHY</p>	<p>PRD supply tubes to be removed are pressurized "live" lines.</p>		<p>WHY</p>	<p>Pressure remains in lines while gas is present in the system.</p>	

5.3. Remove and replace Emer Cylinder Plug PRDs

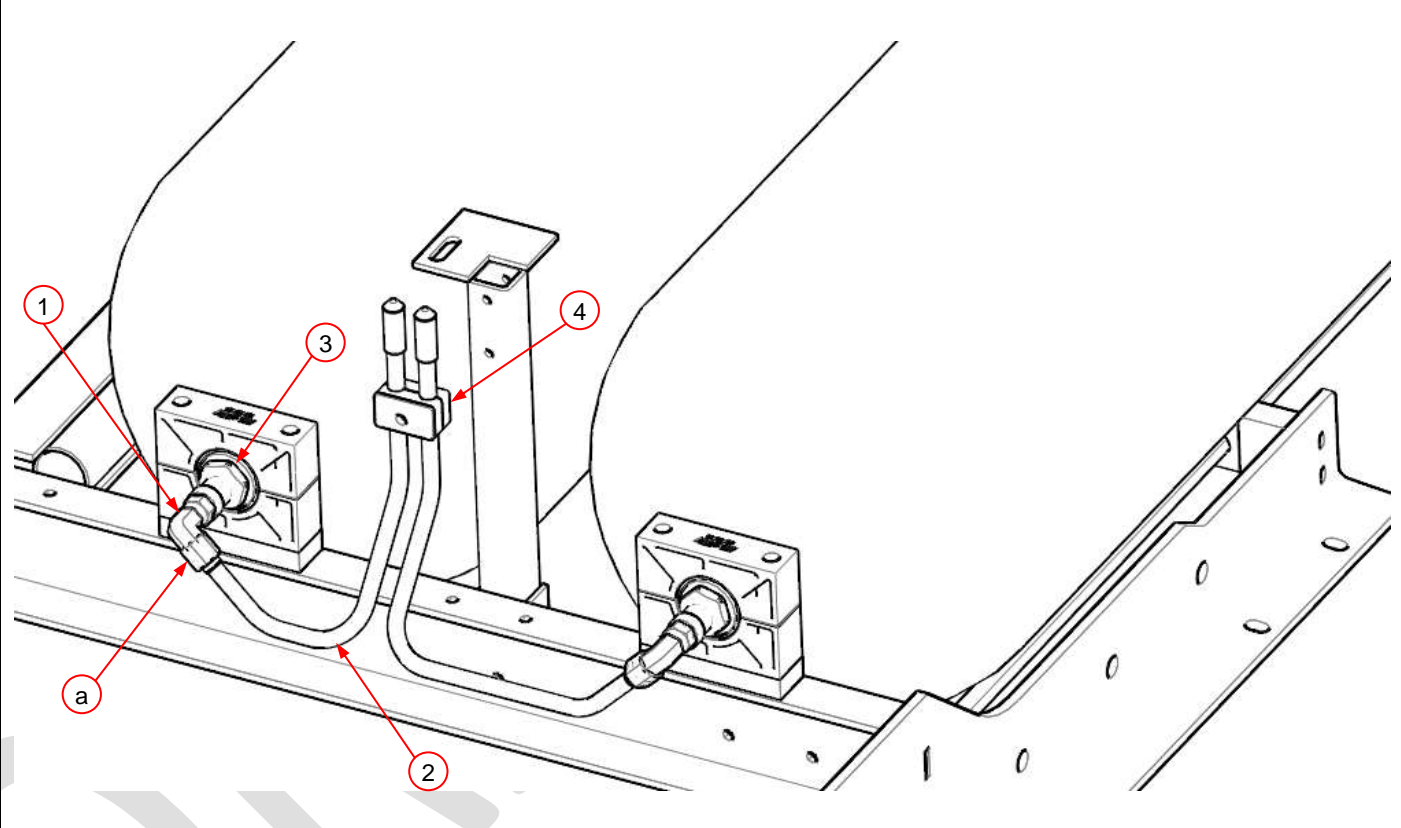
<p>1</p> <p>WHAT</p>	<ol style="list-style-type: none"> 1. Use a microfiber towel and Swagelok® Snoop® to clean PRD (3), elbow fitting (1), and nut fitting (a). 2. Use a wrench to loosen PRD vent tube nut fitting (a) on elbow fitting (1). 3. <i>If necessary:</i> Gently move PRD vent tube (2) to allow easier access to PRD (3). 4. <i>If necessary:</i> Loosen bolt (<i>not visible</i>) securing dual tube clamp (4) to allow PRD vent tube (2) to move. 	
<p>WHY</p>	<p>Prevent debris from entering fuel system.</p>	

2	<ol style="list-style-type: none"> 1. Use two wrenches to remove elbow fitting (1) from PRD (3). 2. Use a wrench to remove PRD (3). 	
WHAT	<p>NOTICE</p> <p><i>Do not allow debris to enter cylinder (5).</i></p> <ol style="list-style-type: none"> 3. Place removed Emer™ PRD in zip lock bag provided with bulk retrofit kit shipment. <p>NOTICE</p> <p><i>Place only PRDs from one vehicle in each zip lock bag.</i></p> <p><i>Bag must be labeled with the following:</i></p> <ol style="list-style-type: none"> 1. Fleet 2. VIN 3. Fuel system s/n 	
WHY	<ol style="list-style-type: none"> 1. Bag helps prevent PRD contamination. 2. Agility is collecting all PRDs removed; return material authorization (RMA) instructions appear below. 	

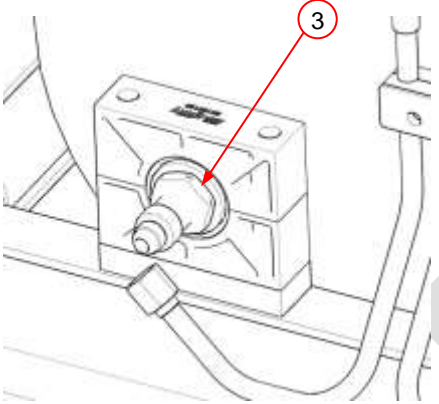
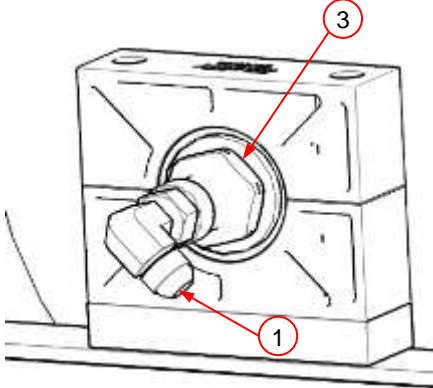
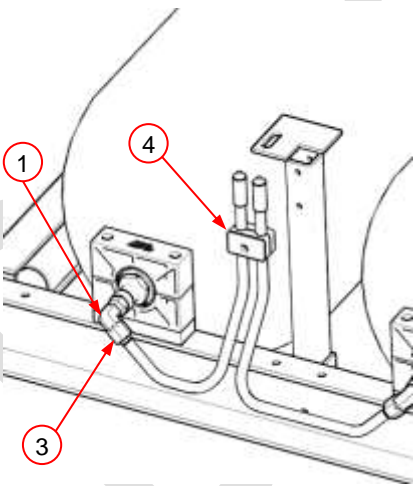
<p>3</p> <p>WHAT</p>	<p>Use a wrench to install replacement Emer™ PRD, p/n, (3).</p> <p>Torque PRD (3) to 140 ft-lbs (190Nm).</p>		<p>4</p> <p>WHAT</p>	<p>Use two wrenches to install elbow fitting (1) on PRD (3).</p> <p>Torque elbow fitting (1) to 45 ft-lbs (61Nm).</p>	
<p>WHY</p>			<p>WHY</p>		
<p>5</p> <p>WHAT</p>	<p>1. Use a wrench to tighten PRD vent tube nut fitting (a) on elbow fitting (1).</p> <p>Torque nut fitting (a) to 45 ft-lbs (61Nm).</p> <p>2. <i>If necessary:</i> Tighten bolt (not visible) securing dual tube clamp (4).</p> <p>Tighten bolt to 8 ft-lbs (11Nm).</p>		<p>6</p> <p>WHAT</p>	<p>Repeat Steps 1 through 5 until all eight Emer™ PRDs have been replaced.</p>	
<p>WHY</p>			<p>WHY</p>		

5.4.1. Mark Emer™ valve end PRDs, Emer™ p/n PRD2102T

<p>1</p> <p>WHAT</p>	<p>A. Use a microfiber towel and water to clean solenoid cylinder valve (3) and valve PRD (1) surfaces.</p> <p>B. Dry the solenoid cylinder valve (3) and valve PRD (1).</p> <p>c</p> <p>C. When PRD is clean and dry: Use a permanent marker or paint marker to legibly write the serial number (a) and batch number (b) from the solenoid cylinder valve (3) on the valve PRD (1) as indicated by the example (circled).</p>	<p>NOTICE Solenoid coil (c) color may vary from illustration.</p>
<p>WHY</p>	<p>Recall reporting mandates recording serial number and batch number data.</p>	

WHAT	<p>2 ▼</p> <p>Use form FT.0321 (d) to record the following data for each Emer™ valve PRD (1):</p> <p>Serial number (a)</p> <p>Batch number (b)</p>		<p>3</p> <p>Repeat Steps 1 and 2 until all valve PRDs have been marked.</p>	
	WHY	<p>Required for retrofit kit component and repair tracking and, if applicable, installer reimbursement.</p>		WHAT

5.4.2. Remove and replace Emer™ Cylinder Valve PRDs

⚠ WARNING

Refer to Appendix A: “OEM Emer Instruction PRD Manual to Replace the PRD” (below) for installation details.

<p>1</p> <p>WHAT</p>	<p>Use a pair of wrenches to disconnect PRD vent tube (6) nut fitting (a) from PRD (1) elbow fitting (7).</p> <p>NOTICE <i>Avoid damage to pressure transducer (d) and high pressure fuel tube (e).</i></p> <p>NOTICE <i>If necessary: Use a wrench to loosen dual tube clamp (8) fasteners (not visible) to aid in moving PRD vent tube (6) aside but do not remove.</i></p>	<p>The diagram shows a PRD assembly with various components labeled. Callout 1 points to the PRD elbow fitting. Callout 6 points to the PRD vent tube. Callout 7 points to the PRD elbow fitting. Callout 8 points to the dual tube clamp fasteners. Callout 'a' points to the nut fitting. Callout 'd' points to the pressure transducer. Callout 'e' points to the high pressure fuel tube.</p>
<p>WHY</p>		

3 Use a wrench to loosen jamb nut (b) of elbow fitting (7) while holding PRD (1) with another wrench at PRD flats (a).

WHAT

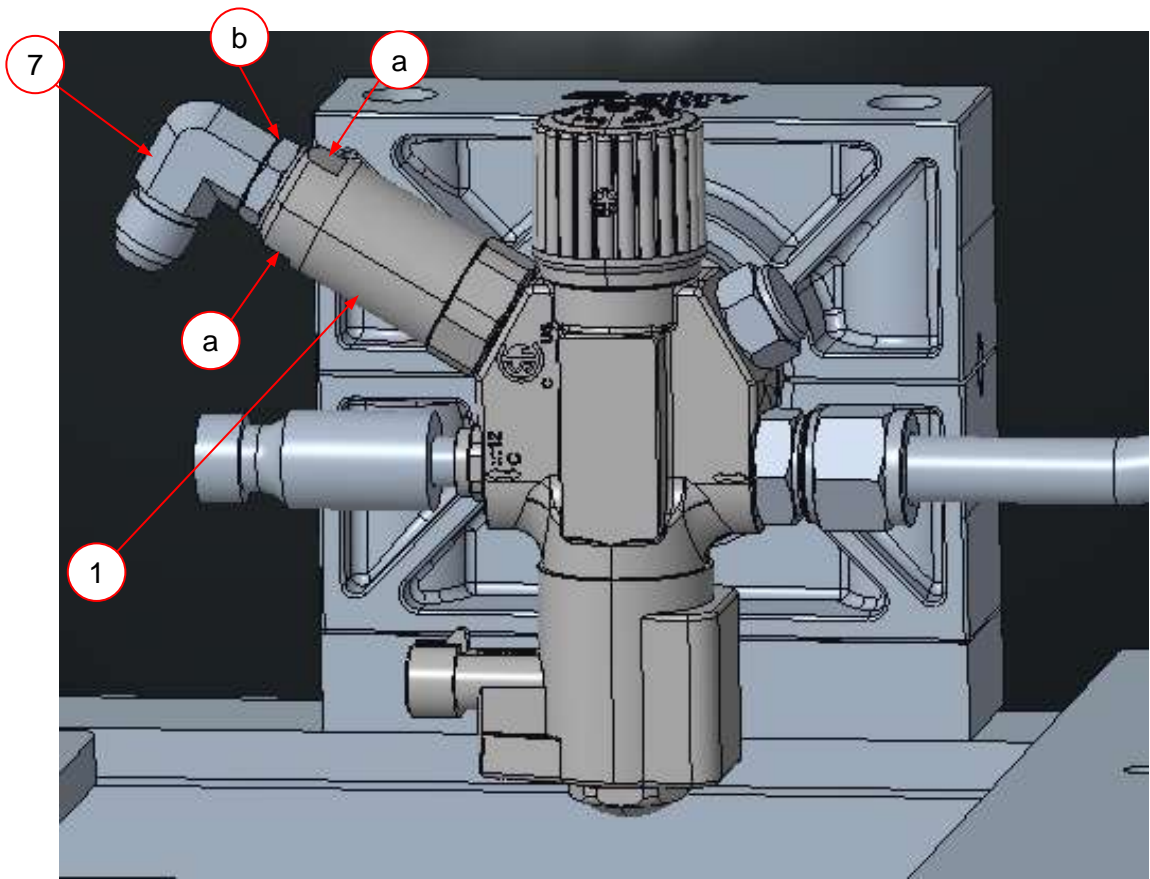

WHY

4

NOTICE
Remove and replace one PRD at a time to avoid system contamination.

1. Use a 15/16-in. angled open end wrench (Tekton[®] p/n WAE83024) (a) OR a modified 1/2-in. drive 24mm deep socket (b) and ratchet to remove PRD (1) from valve (3).

NOTICE
Avoid contact with pressure transducer (d).

2. Place PRD (1) removed in a zip lock bag.

NOTICE
Place only PRDs from one vehicle in each zip lock bag.
Bag must be labeled with the following:



1. Fleet
2. VIN
3. Fuel system s/n

WHAT

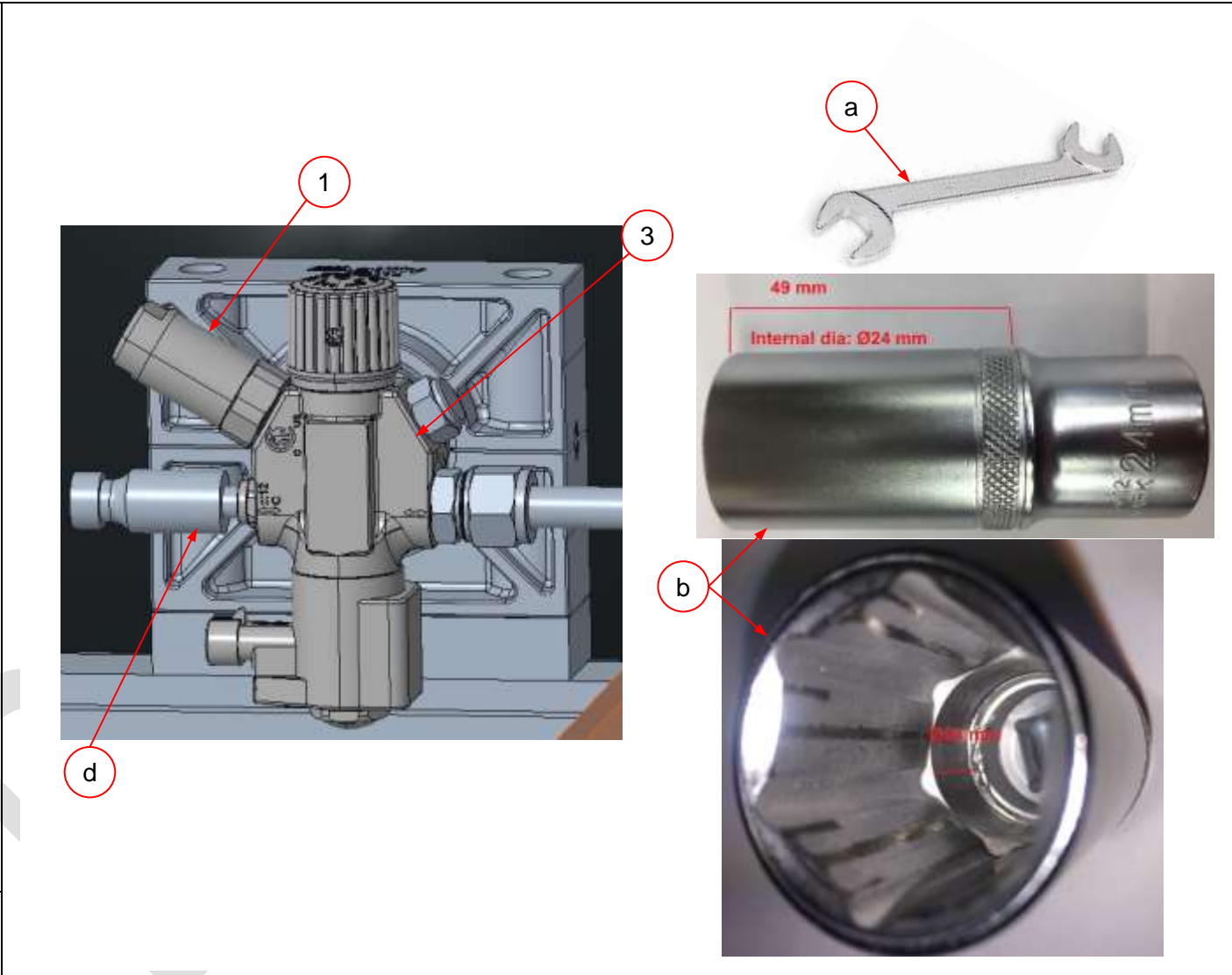
WHY

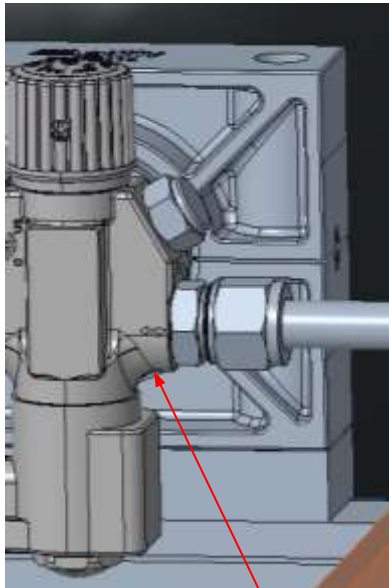
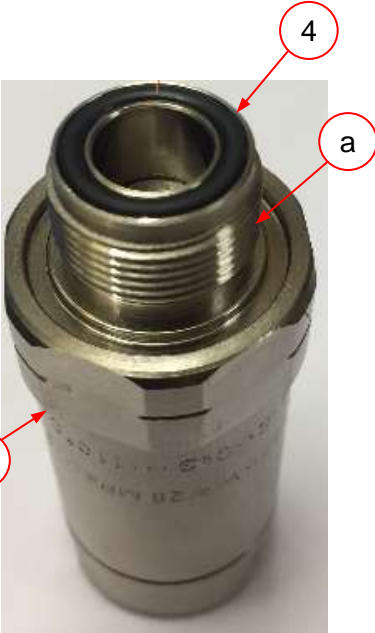

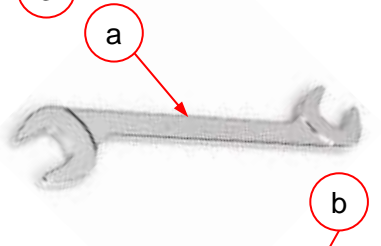
5	<p>1. Use Swagelok[®] Snoop[®] a microfiber towel to clean and inspect valve body (3) PRD port threads and O-ring surfaces (<i>not visible</i>).</p> <p>2. Use Swagelok[®] Snoop[®] and a microfiber towel to remove old Torque Seal from fitting junction (<i>not shown</i>).</p> <p>c</p> <p>3. Apply a light film of Parker[®] O-lube O-ring lube to replacement PRD (5) O-ring (4).</p> <p>4. Verify O-ring (4) is properly seated.</p> <p>c</p> <p>5. Apply Loctite[®] 276 to PRD (5) threads (a).</p>		
WHAT			
WHY	Emer [™] specification.		

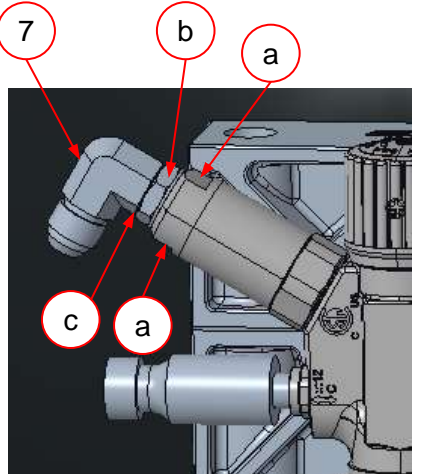
<p style="writing-mode: vertical-rl; transform: rotate(180deg);">WHAT</p>	<p>6 Install PRD (5) on valve body (3) using a 15/16-in. angled open end wrench (Tekton[®] p/n WAE83024) (a) or a modified 1/2-in. drive 24mm deep socket (b) and ratchet (<i>not shown</i>).</p> <p>Torque PRD (5) to 30Nm (22 ft-lbs).</p>	  	<p style="writing-mode: vertical-rl; transform: rotate(180deg);">WHAT</p>	<p>7</p> <ol style="list-style-type: none"> 1. Move jamb nut (b) to base (c) of elbow fitting (7). 2. Use a wrench to install elbow fitting (7) on PRD (1). 3. Use a wrench to hold PRD (1) at PRD flats (a). 4. Position elbow fitting (7) to line up with PRD vent tube (<i>not shown</i>). 5. Tighten elbow fitting jamb nut (b). <p>Torque elbow fitting jamb nut (b) to 45 ft-lbs (61Nm).</p>	
	<p style="writing-mode: vertical-rl; transform: rotate(180deg);">WHY</p>	<p>System specification.</p>		<p style="writing-mode: vertical-rl; transform: rotate(180deg);">WHY</p>	<p>System specification.</p>

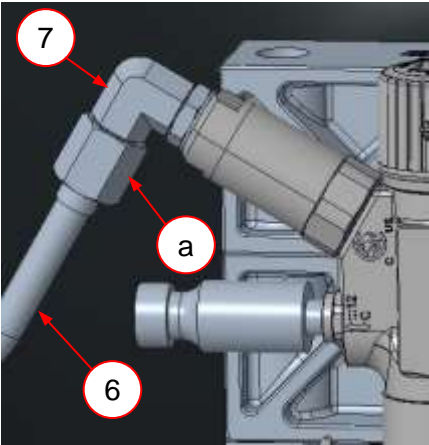
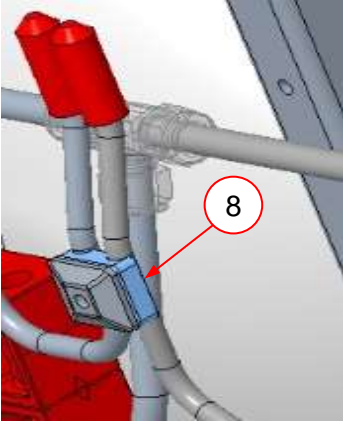
<p>8</p> <p>WHAT</p>	<p>Use a pair of wrenches to install PRD vent tube (6) nut fitting (a) on elbow fitting (7).</p> <p>⚠</p> <p>Torque elbow fitting (7) jam nut (b) to 45 ft-lbs (61Nm).</p>		<p>9</p> <p>WHAT</p>	<p><i>If loosened at Step 1 above:</i> Use a wrench to tighten dual tube clamp (8) fasteners (<i>not visible</i>).</p> <p>⚠</p> <p>Torque tube clamp (8) fasteners to 8 ft-lbs (11Nm).</p>	
<p>WHY</p>	<p>System specification.</p>		<p>WHY</p>	<p>System specification.</p>	
<p>10</p> <p>WHAT</p>	<p>Repeat Steps 1 through 9 until all eight valve end PRDs have been replaced.</p>				
<p>WHY</p>					

5.5. Check PRD vent tube outlet clearance





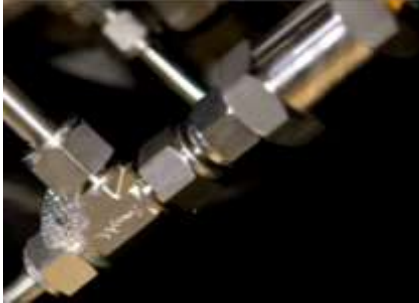
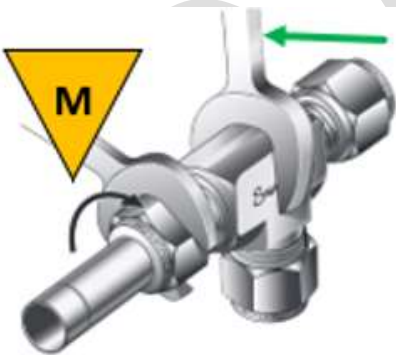

WHAT	<p>1. Gently close one fuel system roof pod door.</p> <p>2. Visually verify proper clearance between plug end PRD vent tube caps (f) and door opening (circled).</p> <p>⚠ WARNING <i>PRD vent tubes cannot protrude above the top of the pod door.</i></p> <p>If PRD vent tube (2) caps (f) protrude above the pod door opening, fuel system plumbing and/or mounting clamps (b) must be adjusted to achieve proper clearance.</p>		WHAT	<p>2. Repeat Step 1 for each roof pod door.</p>	
	WHY	<p>Verify proper PRD vent tube position.</p>		WHY	<p>Verify proper PRD vent tube position.</p>

5.6. System Leak Check Procedure

<p>1</p> <p>WHAT</p>	<p>1. Turn 1/4-turn manual shut off valve (1) on the FMM (2) to the OPEN position.</p> <p>⚠ WARNING</p> <p>2. Select the appropriate CNG fuel nozzle and/or adaptor for the FMM (2) defuel receptacle (3).</p> <p>3. Remove fuel fill receptacle dust cap (<i>not shown</i>).</p> <p>4. Begin fueling the vehicle with CNG using a regulated fuel supply.</p> <p>⚠ C</p> <p><i>Open nozzle valve slowly and regulate gas delivery to prevent connector from icing and reducing or blocking fuel flow.</i></p> <p>⚠ WARNING</p> <p><i>Follow all local and facility fueling regulations and procedures.</i></p>	<p>The diagram illustrates the GILIG CNG fueling station. It features a central 'FUELED VEHICLE' connection point. To the left is a 'FILL RECEPTACLE' with a '3900 PSI' label and a '1958L' volume indicator. A 'MANUAL SHUT-OFF VALVE' (1) is located on the line between the fill and defuel receptacles. To the right is a 'DEFUEL RECEPTACLE' (3). The station is labeled 'GILIG' and 'Agility fuel solutions'. A warning label on the station reads: 'Do Not Inhale Gas Fuel Outdoor RV Inoperative And Breach Life'. A note says 'COMPRESSED REGULAR GAS FUELED VEHICLE'. A date stamp 'NOV 2012' is visible on the station's body.</p>
<p>WHY</p>	<p>Test fuel system integrity.</p>	

<p>2</p> <p>WHAT</p>	<p>Monitor FMM high pressure gauge to verify when system pressure reaches 500 psi to 510 psi (3.45MPa to 3.52MPa) and stop pressurization.</p> <p>⚠ WARNING</p> <p><i>1. If a hissing sound is heard coming from fuel system fittings during filling, stop the fill immediately.</i></p> <p><i>2. Try to isolate the sound and spray Swagelok Snoop[®] on the suspected location to check for bubble formation.</i></p>		<p>3</p> <p>WHAT</p>	<p>C</p> <p>Leak test all fuel and PRD tubes and fitting connections using Swagelok Snoop[®] leak detection solution or equivalent.</p>	
<p>WHY</p>	<p>Subjects fuel system to partial operating pressure.</p>		<p>WHY</p>	<p>Approved leak detection solution for visual inspection of system leaks.</p>	

<p>4</p> <p>WHAT</p>	<p>1. Begin at one end of the fuel system and work methodically to spray all fuel line fittings with Swagelok Snoop[®] or equivalent.</p> <p>2. Allow at least 10 minutes to elapse before checking the integrity of fitting connections.</p>		<p>5</p> <p>WHAT</p> <p>If a leak is audible or icing, condensation, foam, or bubbles appear at a fitting connection the fitting connection must be inspected.</p> <p>⚠ WARNING <i>Fuel system must be defueled prior to investigating any leak. Refer to OEM procedure to defuel system.</i></p>	
<p>WHY</p>			<p>WHY</p>	
<p>6</p> <p>WHAT</p> <p>⚠ <i>Refer to fitting type and size specific tightening specifications.</i></p>	<p>Re-tighten leaking fitting(s) discovered during Step 5.</p>		<p>7</p> <p>WHAT</p> <p>Repeat Steps 1 and 2 to repressurize the system.</p>	
<p>WHY</p>			<p>WHY</p>	

8	WHAT Spray leaking fitting again with Swagelok Snoop [®] or equivalent and allow at least 10 minutes to elapse before checking for bubble formation.		9	WHAT  If leaking fitting is fixed, proceed to test any remaining fitting connections.	
	WHY			WHY	
10	WHAT  WARNING If leak is not fixed, the fuel system must be defueled to replace the fitting.  Perform OEM defuel procedure.		11	WHAT Inspect tubing, fittings, ferrules, and nuts at the site of the leak for perforations, cracks, assembly defects, or other damage.  Any damaged components must be replaced.	
	WHY			WHY	
12	WHAT Replace any related components at the fitting junction as required.		13	WHAT Repressurize fuel system by repeating Step 1 and Step 2.	
	WHY			WHY	

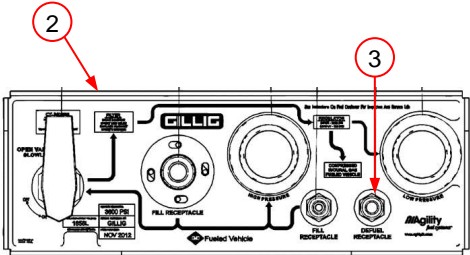
<p>14</p> <p>WHAT</p>	<p>c</p> <p>Spray new fitting junction with Swagelok Snoop[®] or equivalent to retest for leaks.</p>		<p>15</p> <p>WHAT</p>	<p>Turn FMM 1/4-turn manual shut off valve (3) counterclockwise to the OPEN position.</p>	
<p>WHY</p>			<p>WHY</p>	<p>Allow fuel into system.</p>	
<p>16</p> <p>WHAT</p>	<p>c</p> <p>Repeat pressure test procedure stopping the fill when fuel system pressure reaches 2000 psi to 2100 psi (13.79MPa to 14.48MPa).</p>		<p>17</p> <p>WHAT</p>	<p>c</p> <p>Repeat pressure test procedure stopping the fill when fuel system pressure reaches 3600 psi to 3700 psi (24.8MPa to 25.5MPa) and repeat leak checking all connections until entire fuel system is confirmed leak free.</p>	
<p>WHY</p>	<p>Subjects fuel system to partial operating pressure.</p>		<p>WHY</p>	<p>Subjects fuel system to full operating pressure.</p>	
<p>18</p> <p>WHAT</p>	<p>c</p> <p>If fuel system is leak free or if defueling is required, close flow valve on CNG dispense nozzle (not shown) and carefully disconnect fill nozzle (not shown) from FMM (2) defuel receptacle (3).</p>		<p>19</p> <p>WHAT</p>	<p>Replace dust cap (not shown) on FMM defuel receptacle.</p>	
<p>WHY</p>			<p>WHY</p>	<p>Vehicle will not start if dust cap is not in place.</p>	

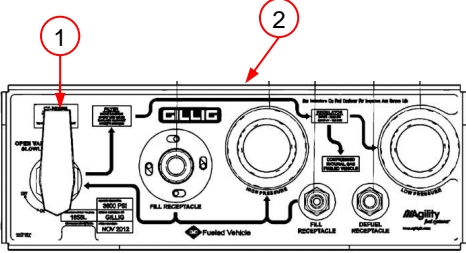
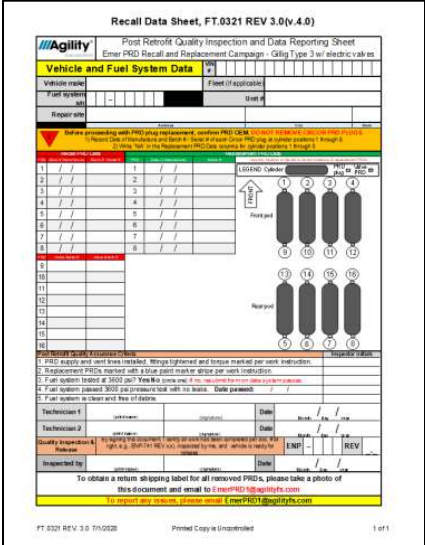
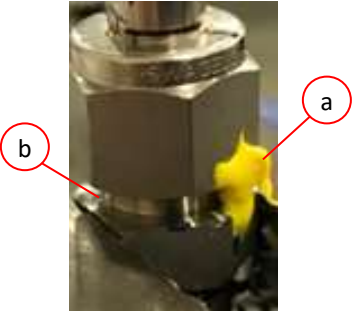
<p>20</p> <p>WHAT</p>	<p>If not open, turn FMM (2) 1/4-turn manual shut off valve (1) counter-clockwise to the OPEN position.</p>		<p>21</p> <p>c</p> <p>Clean Swagelok® Snoop® or equivalent from the fuel system.</p>	
<p>WHY</p>	<p>Allow gas to flow throughout fuel system.</p>		<p>WHY</p> <p>Customer satisfaction.</p>	
<p>22</p> <p>WHAT</p>	<p>c</p> <p>When the pressure test is completed successfully, use form FT.0321 (c) to record the result and the date on which the fuel system passed the 3600 psi test.</p>	<p>c</p> 	<p>23</p> <p>Apply Torque Seal to all fitting junctions.</p>	
<p>WHY</p>	<p>Verify safe and proper fuel system pressure specification.</p>		<p>System quality specification.</p>	

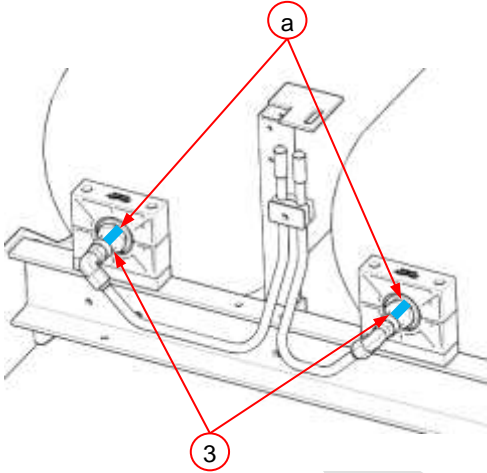
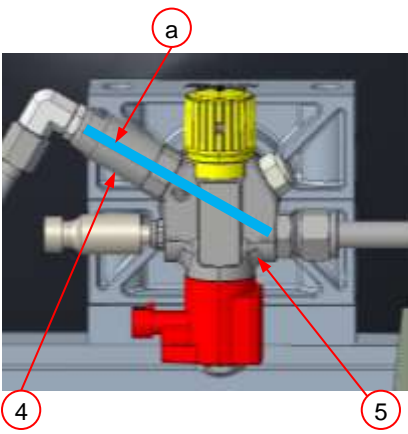
24	<p>c</p> <p>WHAT</p> <p>Use a blue paint marker to mark a stripe (a) on all eight cylinder plug PRDs (3) replaced.</p>	 <p>A technical line drawing of two cylinder plug PRDs. A blue stripe, labeled 'a', is drawn across the top of each PRD. Red arrows point from a circled 'a' at the top to the stripes on both PRDs. A circled '3' at the bottom has red arrows pointing to the two PRDs.</p>	25	<p>c</p> <p>WHAT</p> <p>Use a blue paint marker to mark a stripe (a) on all eight cylinder valve PRDs (4) replaced and on the valve body (5).</p>	 <p>A 3D CAD model of a cylinder valve PRD assembly. A blue stripe, labeled 'a', is drawn across the top of the valve body. Red arrows point from a circled 'a' at the top to the stripe. A circled '4' at the bottom left has red arrows pointing to the two valve PRDs. A circled '5' at the bottom right has a red arrow pointing to the valve body.</p>
WHY	<p>Easily identify replaced cylinder plug PRDs.</p>		<p>Easily identify replaced cylinder valve PRDs.</p>		

DRAFT

5.7. Reporting and Return Procedure

1a	<p>c 1. Use form FT.0321 (c) to record the Date of Manufacture (a) and batch number (b) and the location of each replacement plug PRD (16), p/n 10301046, within the fuel system.</p> <p>2. Inspect fuel system repairs per the quality assurance criteria specified in FT.0321.</p> <p>NOTICE Use a flashlight to aid serial number identification in low light.</p> <p>3. Use a camera/phone to photograph completed form FT.0321 (c).</p> <p>4. Submit photo of completed form FT.0321 (c) to the email address indicated on the form to receive a Return Material Authorization (RMA) shipping label.</p>
WHAT	
WHY	Required for retrofit kit component and repair tracking and, if applicable, installer reimbursement.



c

Recall Data Sheet, FT.0321 REV 3.0(v.4.0)

Agility		Post Retrofit Quality Inspection and Data Reporting Sheet	
Emer PRD Recall and Replacement Campaign - Gligi Type 3 w/ electric valves			
Vehicle and Fuel System Data		VIN #	
Vehicle make		Fleet (if applicable)	
Fuel system		Unit #	
Repair site			
<p>Before proceeding with PRD plug replacement, confirm PRD OEM. DO NOT REMOVE LUBRICANT FROM PLUGS.</p> <p>1) Record Date of Manufacture and Batch #. Scan # of each Green PRD plug at higher positions 1 through 8.</p> <p>2) Write "Yes" in the Replacement PRD Data columns for cylinder positions 1 through 8.</p>			
1	2	3	4
5	6	7	8
9	10	11	12
13	14	15	16
<p>LEGEND Cylinder</p> <p>↑ FRONT</p> <p>1 2 3 4</p> <p>5 6 7 8</p> <p>9 10 11 12</p> <p>13 14 15 16</p> <p>↓ REAR</p>		<p>PRD plug #</p> <p>PRD #</p>	
<p>Post Retrofit Quality Assurance Criteria</p> <p>1. PRD supply and vent lines installed, fittings tightened and torque marked per work instruction.</p> <p>2. Replacement PRDs marked with a blue paint marker stripe per work instruction.</p> <p>3. Fuel system tested at 3600 psi? Yes/No (mark one) if no, no submit for more data system details.</p> <p>4. Fuel system passed 3600 psi pressure test with no leaks. Date passed: / /</p> <p>5. Fuel system is clean and free of debris.</p>			
Technician 1	Signature	Date	Work / Ins / Test
Technician 2	Signature	Date	Work / Ins / Test
Quality Inspection & Release	<p>Following this document, verify all work has been completed per this RMA (e.g. SHP-741 REV XXX) installed by me, and vehicle is ready for return.</p>		<p>ENT -</p> <p>REV -</p>
Inspected by	Signature	Date	Work / Ins / Test
<p>To obtain a return shipping label for all removed PRDs, please take a photo of this document and email to EmerPRD1@agilityfs.com</p> <p>To report any issues, please email EmerPRD1@agilityfs.com</p>			
FT.0321 REV 3.0 7/1/2020		Printed Copy is Uncontrolled	
1 of 1			

<p style="text-align: center;">2</p> <p style="writing-mode: vertical-rl; transform: rotate(180deg);">WHAT</p>	<p>Repeat Section 5. Corrective Action / Procedure for all vehicles subject to the Emer™ PRD recall on hand until all repairs are complete.</p>		<p style="text-align: center;">3</p> <p style="writing-mode: vertical-rl; transform: rotate(180deg);">WHAT</p>	<p style="text-align: center;">c</p> <ol style="list-style-type: none"> 1. Pack all removed PRDs (still bagged by VIN), in one box. If the quantity of PRDs is too large for a single box, use additional boxes but ship them all using the same RMA. <i>If possible:</i> reuse the box in which the replacement PRDs were shipped. 2. Apply RMA label obtained from Agility® to the box. 3. Use a permanent marker to write RMA number on exterior of each shipping box. 	
<p style="writing-mode: vertical-rl; transform: rotate(180deg);">WHY</p>			<p style="writing-mode: vertical-rl; transform: rotate(180deg);">WHY</p>	<p>Required for repair return tracking and, if applicable, installer reimbursement.</p>	

Appendix A. Emer™ Instruction Manual to Replace the PRD

MOD 8.7-03 Rev01



INSTRUCTION MANUAL TO REPLACE THE PRD

GENERAL INSTRUCTIONS

Read carefully the instructions before proceeding with the replacement of the Pressure Relief Device (PRD) Temperature Activated. The maintenance described hereinafter shall be done only by the authorized workshops/operators after Emer S.p.A. approval.

Don't damage or tamper in any way the valve and its equipment.

Don't use components having damaged packaging, fallen or showing sign of collision and/or damages.

Don't make operations different from those explicitly described in this instruction manual.

All the equipment used for the hereinafter listed operations, shall be suitable to the using and calibrated (where applicable).

For what not expressly described, the indication reported within the standard ISO 19078 "Gas cylinders — Inspection of the cylinder installation, and requalification of high pressure cylinders for the on-board storage of natural gas as a fuel for automotive vehicles" and the following have to be used.



Before conducting following activities it is mandatory that inside the CNG tank and the downstream systems there isn't any residual pressure. This means that the tank, the piping, etc. should be completely vented.

Pay attention not to damage the components during the following activities.

Emer S.p.A. - a Westport Fuel Systems company

Via Bormioli 19 • 25135 • Brescia • Italy - Tel +39 030 2510391 • Fax +39 030 2510392 • emer.westport.com

1. Unpack the fresh PRD keeping the plastic bag, the protective plastic cap and the main carton box.
2. Unscrew the PRD Part 2 at **Fig 1**.
3. Remove the previous O-ring from the seat at the valve body, blow compressed air into the seat of the PRD and check that the fresh PRD is having the O-ring at the proper seat.
4. Apply the sealant as specified at **Table 1** on the threads of the new PRD and screw the PRD into the threaded seat at the valve body.
5. Tighten the PRD with a dynamometric key size 24 set at a torquing value as declared in **Table 1**.
6. Pressurize the system at min 200 bar with CNG. The pressurizing of the CNG can be done either with a back-up CNG tank or at the CNG filling station. Do not use CNG fast filling stations for pressurizing the systems. In case of multiple tanks all the tanks must be pressurized (all the PRDs present in the system should be replaced before conducting the leak test at Step No 7).
7. Check the tightness of the PRD at the sealing area of the valve using either sniffer measuring machine (preferably) or with snoop solution (in case sniffer machine is not available). With snoop solution the PRD is leak proof in case of no bubbles. If sniffer machine is used please contact Emer at emer-service@wfsinc.com specifying the technical details of machine for defining acceptance criteria.

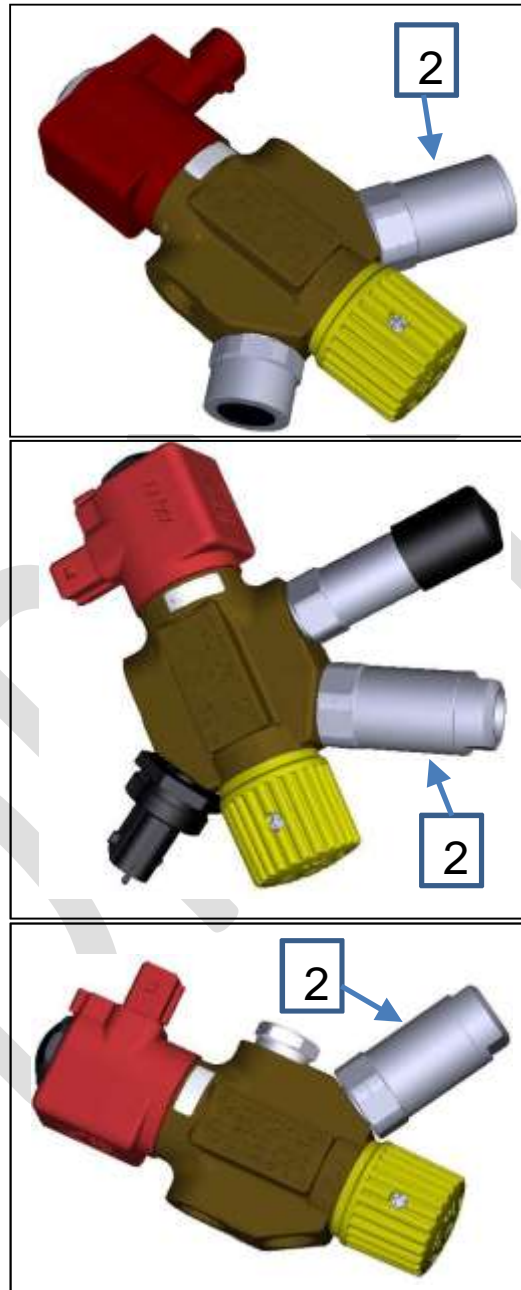

Fig 1

S. No	Tank Valve Part No	PRD Type	PRD thread	Torqueing value	Glue
1	MARK106-006	PRD100OR	M16x1	30±15% Nm	Loctite 276 - 4 mg
2	MARK114	PRD2002T	M16x1	30±15% Nm	Loctite 276 - 4 mg
3	MARK121-004	PRD200OR	M16x1	30±15% Nm	Loctite 276 - 4 mg
4	MARK131-003	PRD200OR	M16x1	30±15% Nm	Loctite 276 - 4 mg
5	MARK137-001	PRD200OR	M16x1	30±15% Nm	Loctite 276 - 4 mg
6	MARK139	PRD200OR	M16x1	30±15% Nm	Loctite 276 - 4 mg
7	MARK147-005	PRD200OR	M16x1	30±15% Nm	Loctite 276 - 4 mg
8	MARK147-008	PRD2102T	M16x1	60±10 Nm	Loctite 276 - 4 mg
9	MARK155-001	PRD210ORMP	M16x1	30±15% Nm	Loctite 276 - 4 mg
10	MARK156-003	PRD2102T	M16x1	60±10 Nm	Loctite 276 - 4 mg
11	MARK156-006	PRD2102T	M16x1	30±15% Nm	Loctite 276 - 4 mg
12	MARK160	PRD100OR	M16x1	30±15% Nm	Loctite 276 - 4 mg
13	MARK163-003	PRD200OR	M16x1	30±15% Nm	Loctite 276 - 4 mg
14	MARK169	PRD210OR	M16x1	30±15% Nm	Loctite 276 - 4 mg
15	MARK193	PRD200OR	M16x1	30±15% Nm	Loctite 276 - 4 mg
16	MARK199-003	PRD210OR	M16x1	30±15% Nm	Loctite 276 - 4 mg
17	MARK199-004	PRD210OR	M16x1	30±15% Nm	Loctite 276 - 4 mg
18	MARK199-006	PRD2102T	M16x1	30±15% Nm	Loctite 276 - 4 mg
19	MARK703-002	PRD217OR	M16x1	30±15% Nm	Loctite 276 - 4 mg

Table 1

Emer S.p.A. declines any responsibility for eventual damages due to person, things or animals directly and indirectly, as a consequence of non-observation of instructions and assembly, use and maintenance directions of the component.

For every controversy concerning the execution and/or interpretation of the present contract, it is applicable the Italian Law and the place of jurisdiction is Brescia's court of justice.

In case of any assistance, contact Emer S.p.A. at emer-service@wfsinc.com

6. Warranty Information

This procedure is covered under warranty. Standard repair time (SRT) is TBA. Please refer to Warranty Manual, ENP-067, for warranty reimbursement procedures.

For parts and support, contact Agility Fuel Solutions Customer Care:

+1 949 267 7745

+1 855 500 2445 toll free

parts@agilityfs.com

Proprietary Statement

The information provided within this document is proprietary and confidential. All prior versions, including updates and revisions forwarded separately, are proprietary. The information provided by Agility® to its customers and clients is solely for the use of those customers and clients. No portion of this publication may be reproduced or distributed without express written consent of Agility®. Agility® reserves the right to utilize the intellectual property contained within this publication as content for any other publication produced by Agility®.

Trademark Notice

Agility® is a registered trademark of Agility Fuel Solutions LLC. Trademarks of other manufacturers are the property of their respective companies.

Agility Fuel Solutions
 3335 Susan Street, Suite 100
 Costa Mesa, CA 92626 USA
www.agilityfuelsolutions.com

Revision	Description	Author	Approved By	Date
--	Initial Release	C. Grasso	CCG Team	06/02/2020
A	DELETED: Instructions to return PRDs to Emer™ from Appendix A.	C. Grasso	CCG Team	06/05/2020
B	ADDED: Instruction to capture solenoid valve serial number and batch number data for each valve PRD removed.	C.Grasso	CCG Team	08/05/2020