

August 2020  
FL834A-F  
NHTSA #19V-722  
Transport Canada #19-508

## **Subject: Western Star Baggage and Sleeper Doors**

**Models Affected: Specific Model Years 2017-2020 Western Star 4900 and 5700 model vehicles manufactured November 14, 2016, through September 12, 2019, and equipped with certain baggage and sleeper doors.**

### **General Information**

Daimler Trucks North America LLC (DTNA), on behalf of its wholly owned subsidiary, Western Star Truck Sales, Inc., has decided that a defect that relates to motor vehicle safety exists on the vehicles mentioned above.

On certain vehicles, the baggage and sleeper doors may separate from the hinge assembly. A baggage or sleeper door separating from the vehicle whilst in motion could lead to debris on the road increasing the risk of an injury and/or crash.

For the final repair, reinforcement clips/hinges with mechanical fasteners and stronger gauge screws will be installed on each baggage and sleeper door hinge.

**NOTE: All vehicles that had the INT FL834 interim repair preformed require the stronger gauge screws in the final repair.**

There are approximately 15,600 vehicles involved in this campaign.

### **Additional Repairs**

Dealers must complete all outstanding Recall and Field Service campaigns prior to the sale or delivery of a vehicle. A Dealer will be liable for any progressive damage that results from its failure to complete campaigns before sale or delivery of a vehicle.

Owners may be liable for any progressive damage that results from failure to complete campaigns within a reasonable time after receiving notification.

### **Work Instructions**

Please refer to the attached work instructions. Prior to performing the campaign, check the vehicle for a completion sticker (Form WAR260).

### **Replacement Parts**

Replacement parts are now available and can be obtained by ordering the kit and/or part number(s) listed below from your facing Parts Distribution Center.

If our records show your dealership has ordered any vehicle(s) involved in campaign number FL834, a list of the customers and vehicle identification numbers will be available on DTNAConnect. Please refer to this list when ordering parts for this recall.

August 2020  
FL834A-F  
NHTSA #19V-722  
Transport Canada #19-508

**Table 1** - Replacement Parts for FL834

Campaign Number	Part Description	Part Number	Qty.
FL834A	CLIP-REINF,DOOR,SLEEPER	18-73497-000	6 ea
	SCREW-SLFDLG,SST,PNH,8-18X5/8	23-14673-705	
FL834B	CLIP-REINF,DOOR,SLEEPER	18-73497-000	4 ea
	SCREW-SLFDLG,SST,PNH,8-18X5/8	23-14673-705	
FL834C	CLIP-REINF,DOOR,SLEEPER	18-73497-000	8 ea
	SCREW-SLFDLG,SST,PNH,8-18X5/8	23-14673-705	
FL834D	SCREW-SLFDLG,SST,PNH,8-18X5/8	23-14673-705	6 ea
FL834E	SCREW-SLFDLG,SST,PNH,8-18X5/8	23-14673-705	4 ea
FL834F	SCREW-SLFDLG,SST,PNH,8-18X5/8	23-14673-705	8 ea
FL834A-F	BLANK COMPLETION STICKER	WAR260	1 ea

**Table 1**

## Removed Parts

U.S. and Canadian Dealers, please follow Warranty Failed Parts Tracking shipping instructions for the disposition of all removed parts. Export distributors, please destroy removed parts unless otherwise advised.

## Labor Allowance

**Table 2** - Labor Allowance

Campaign Number	Procedure	Time Allowed (hours)	SRT Code	Corrective Action
FL834A	Install clip, hinge support for 2 baggage doors and 1 sleeper door	1.5	996-R104B	12-Repair Recall/Campaign
FL834B	Install clip, hinge support for 2 baggage doors	0.9	996-R104A	
FL834C	Install clip, hinge support for 2 baggage doors and 2 sleeper doors	2.2	996-R104C	
FL834D	Replace tapping screws used in interim repair for 2 baggage doors and 1 sleeper door	0.9	996-R104E	
FL834E	Replace tapping screws used in interim repair for 2 baggage doors	0.5	996-R104D	
FL834F	Replace tapping screws used in interim repair for 2 baggage doors and 2 sleeper doors	1.3	996-R104F	

**Table 2**

**IMPORTANT:** When the Recall has been completed, locate the base completion label in the appropriate location on the vehicle, and attach the red completion sticker provided in the recall kit (Form WAR260). If the vehicle does not have a base completion label, clean a spot on the appropriate location of the vehicle and first attach the base completion label (Form WAR259). If a recall kit is not required or there is no completion sticker in the kit, write the recall number on a blank sticker and attach it to the base completion label.

## Claims for Credit

You will be reimbursed for your parts, labor, and handling (landed cost for Export Distributors) by submitting your claim through the Warranty system within 30 days of completing this campaign. Please reference the following information in OWL:

- Claim type is **Recall Campaign**.
- In the Campaign field, enter the campaign number and appropriate condition code (e.g. **FL834-A, FL834-B, etc.**).

**August 2020  
FL834A-F  
NHTSA #19V-722  
Transport Canada #19-508**

- In the Primary Failed Part Number field, enter **25-FL834-000**.
- In the Parts field, enter the appropriate kit or part number(s) as shown in the Replacement Parts Table.
- In the Labor field, first enter the appropriate SRT from the Labor Allowance Table. Administrative time will be included automatically as SRT 939-6010A for 0.3 hours.
- The VMRS Component Code is **F99-999-005** and the Cause Code is **A1 - Campaign**.
- **U.S. and Canada -- Reimbursement for Prior Repairs.** When a customer asks about reimbursement, please do the following:
  - Accept the documentation of the previous repair.
  - Make a brief check of the customer's paperwork to see if the repair may be eligible for reimbursement. (See the "Copy of Owner Letter" section of this bulletin for reimbursement guidelines.)
  - Submit an OWL Recall Pre-Approval Request for a decision.
  - Include the approved amount on your claim in the Other Charges section.
  - Attach the documentation to the pre-approval request.
  - If approved, submit a based on claim for the pre-approval.
  - Reimburse the customer the appropriate amount.

**IMPORTANT:** OWL must be viewed prior to performing the recall to ensure the vehicle is involved and the campaign has not been previously completed. Also, check for a completion sticker prior to beginning work.

U.S. and Canadian dealers, contact the Warranty Campaigns Department via Web inquiry at [DTNACconnect.com](http://DTNACconnect.com) / WSC, if you have any questions or need additional information. Export distributors, submit a Web inquiry or contact your International Service Manager.

U.S. and Canadian Dealers: To return excess kit inventory related to this campaign, U.S. dealers must submit a Parts Authorization Return (PAR) to the Memphis PDC. Canadian dealers must submit a PAR to their facing PDC. All kits must be in resalable condition. PAR requests must include the original purchase invoice number. Export Distributors: Excess inventory is not returnable.

The letter notifying U.S. and Canadian vehicle owners is included for your reference.

Please note that the National Traffic and Motor Vehicle Safety Act, as amended (Title 49, United States Code, Chapter 301), requires the owner's vehicle(s) be corrected within a reasonable time after parts are available to you. The Act states that failure to repair a vehicle within 60 days after tender for repair shall be prima facie evidence of an unreasonable time. However, circumstances of a particular situation may reduce the 60 day period. Failure to repair a vehicle within a reasonable time can result in either the obligation to (a) replace the vehicle with an identical or reasonably equivalent vehicle, without charge, or (b) refund the purchase price in full, less a reasonable allowance for depreciation. The Act further prohibits dealers from selling a vehicle unless all outstanding recalls are performed. Any lessor is required to send a copy of the recall notification to the lessee within 10 days. Any subsequent stage manufacturer is required to forward this notice to its distributors and retail outlets within five working days.

August 2020  
FL834A-F  
NHTSA #19V-722  
Transport Canada #19-508

## Copy of Notice to Owners

### Subject: Western Star Baggage and Sleeper Doors

**For the Notice to U.S. Customers:** This notice is sent to you in accordance with the National Traffic and Motor Vehicle Safety Act. **For the Notice to Canadian Customers:** This notice is sent to you in accordance with the requirements of the Motor Vehicle Safety Act. This is to inform you that your vehicle may contain a defect that could affect the safety of a person.

Daimler Trucks North America LLC (DTNA), on behalf of its wholly owned subsidiary, Western Star Truck Sales, Inc., has decided that a defect that relates to motor vehicle safety exists on specific Model Years 2017-2020 Western Star 4900 and 5700 model vehicles manufactured November 14, 2016, through September 12, 2019, and equipped with certain baggage and sleeper doors.

On certain vehicles, the baggage and sleeper doors may separate from the hinge assembly. A baggage or sleeper door separating from the vehicle whilst in motion could lead to debris on the road increasing the risk of an injury and/or crash.

For the final repair, reinforcement clips/hinges with mechanical fasteners and stronger gauge screws will be installed on each baggage and sleeper door hinge.

**NOTE: All vehicles that had the INT FL834 interim repair preformed still require the stronger gauge screws in the final repair.**

Please contact an authorized Daimler Trucks North America dealer to arrange to have the Recall performed and to ensure that parts are available at the dealership. To locate an authorized dealer, go to [www.Daimler-TrucksNorthAmerica.com](http://www.Daimler-TrucksNorthAmerica.com). On the menu tab, select "Contact," scroll down to "Find a Dealer," and select the appropriate brand. The Recall will take approximately one to three hours, depending on the repair, and will be performed at no charge to you. You may also confirm your vehicle's involvement in this recall at this URL: <https://dtna-dlrinfo.prd.freightliner.com:48518/VinLookup/vin-module/getVinLookupPage>.

You may be liable for any progressive damage that results from your failure to complete the Recall within a reasonable time after receiving notification.

If you do not own the vehicle that corresponds to the identification number(s) which appears on the Recall Notification, please return the notification to the Warranty Campaigns Department with any information you can furnish that will assist us in locating the present owner. If you have leased this vehicle, Federal law requires that you forward this notice to the lessee within 10 days. If you are a subsequent stage manufacturer, Federal law requires that you forward this notice to your distributors and retail outlets within five working days. If you have paid to have this recall condition corrected prior to this notice, you may be eligible to receive reimbursement. Please see the reverse side of this notice for details.

If you have questions about this Recall, please contact the Warranty Campaigns Department at (800) 547-0712, 7:00 a.m. to 4:00 p.m. Pacific Time, Monday through Friday, e-mail address [DTNA.Warranty.Campaigns@Daimler.com](mailto:DTNA.Warranty.Campaigns@Daimler.com). For other concerns, you may contact the Customer Assistance Center at (800) 385-4357. **For the Notice to U.S. Customers:** If you are not able to have the defect remedied without charge and within a reasonable time, you may wish to submit a complaint to the Administrator, National Highway Traffic Safety Administration, 1200 New Jersey Avenue, SE., Washington, DC 20590; or call the Vehicle Safety Hotline at (888) 327-4236 (TTY: 800-424-9153); or to <http://www.safercar.gov>. **For the Notice to Canadian Customers:** If you have a safety concern relating to this Recall, you may wish to contact Transport Canada – Motor Vehicle Safety at, 80 rue Noel, Gatineau, Quebec J8Z 0A1 or phone (800) 333-0510.

We regret any inconvenience this action may cause but feel certain you understand our interest in motor vehicle safety.

WARRANTY CAMPAIGNS DEPARTMENT  
Enclosure

**August 2020  
FL834A-F  
NHTSA #19V-722  
Transport Canada #19-508**

## **Reimbursement to Customers for Repairs Performed Prior to Recall**

If you have already **paid** to have this recall condition corrected you may be eligible to receive reimbursement.

Requests for reimbursement may include parts and labor. Reimbursement may be limited to the amount the repair would have cost if completed by an authorized Daimler Trucks North America LLC dealer. The following documentation must be presented to your dealer for consideration for reimbursement.

Please provide original or clear copies of all receipts, invoices, and repair orders that show:

- The name and address of the person who paid for the repair
- The Vehicle Identification Number (VIN) of the vehicle that was repaired
- What problem occurred, what repair was done, when the repair was done
- Who repaired the vehicle
- The total cost of the repair expense that is being claimed
- Proof of payment for the repair (such as the front and back of a cancelled check or a credit card receipt)

Reimbursement will be made by check from your Daimler Trucks North America LLC dealer.

Please speak with your Daimler Trucks North America LLC authorized dealer concerning this matter.

August 2020  
FL834A-F  
NHTSA #19V-722  
Transport Canada #19-508

## Work Instructions

### Subject: Western Star Baggage and Sleeper Doors

**Models Affected: Specific Model Years 2017-2020 Western Star 4900 and 5700 model vehicles manufactured November 14, 2016, through September 12, 2019, and equipped with certain baggage and sleeper doors.**

NOTE: Vehicles in FL834A-C did **NOT** have INT FL834 performed; proceed with the Baggage and Sleeper Door Hinge Reinforcement below.

Vehicles in FL834D-F had the INT FL834 performed; go to Door Hinge Screw Replacement on page 8.

### Baggage and Sleeper Door Hinge Reinforcement (FL834A, B, and C)

IMPORTANT: Perform this procedure on all baggage and sleeper doors on the vehicle. Trimming material from the door flange and from the hinge will be required to provide clearance for the new clips and fasteners.

**NOTE:** An FL834 completion sticker may not be a good indication that the final repair has been completed, as some dealers may have installed a sticker during the INT FL834 interim repair.

1. Check the Coverage Info screen in OWL for an FL834 "final" repair claim indicating this work has been done. If a claim is present, no work is needed. If there is no claim, proceed with the next step.
2. Park the vehicle on a flat surface, set the parking brake, shut down the engine. Chock the tires.
3. Open and remove the baggage or sleeper door.
  - For sleeper door removal instructions refer to **Section 72.02, Subject 100** in the *Western Star Workshop Manual*.
  - For baggage door removal instructions refer to **Section 72.01, Subject 110** in the *Western Star Workshop Manual*.
4. Using tape, mask off the portions of the door flange and hinge that will be marked and trimmed.

NOTE: The trimmed out notch only needs to be large enough for the screw head to pass through.

5. Mark out the areas of the door flange to be trimmed to allow tool access for a #8 self tapping screw. See **Fig. 1**, ref. **A**.
  - 5.1 Holding the bracket in place, mark the outer flange using the fastener hole in the bracket as a guide. This mark will be the centerline of the tool access notch.
6. Notch the door flange surface. See **Fig. 2**.
  - 6.1 Using a rotary tool, cut a 10mm circular notch in the flange, extending the notch halfway down the flange.

NOTE: The farther the notch is extended into the flange the more noticeable it will be once the door is reinstalled onto the vehicle.

- 6.2 Check for fastener installation clearance. If needed, extend the notch further.

August 2020  
FL834A-F  
NHTSA #19V-722  
Transport Canada #19-508

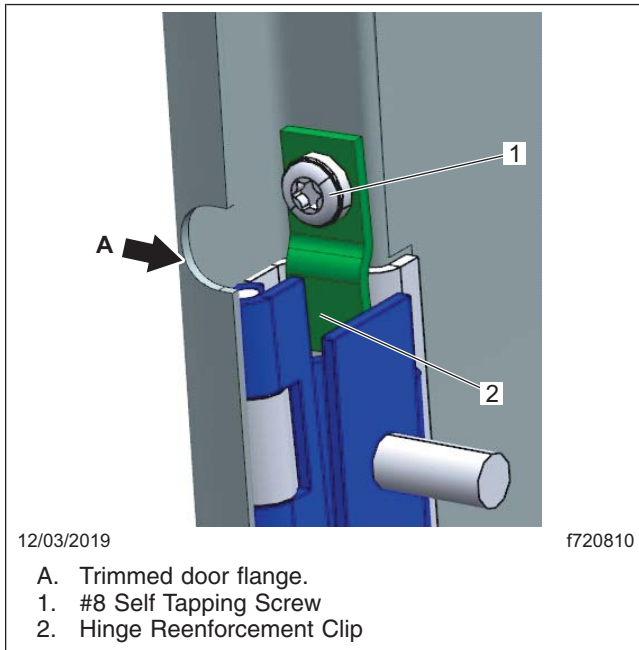
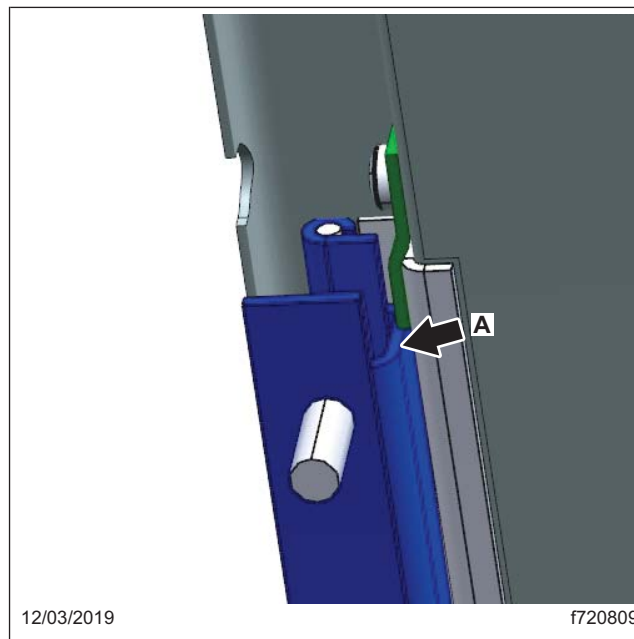

**Fig. 1, Door Flange Trim Location**



**Fig. 2, Trimmed Baggage Door Flange**

7. Mark out the areas of the door hinge that will need to be trimmed to allow clearance for the new clip. See **Fig. 3**, ref. **A**.
8. Trim the door hinge as shown in **Fig. 3**. Trimming past the bend in the hinge to allow full range of motion.



**Fig. 3, Door Hinge Trim Location**

August 2020  
FL834A-F  
NHTSA #19V-722  
Transport Canada #19-508

9. Install the new clips to the top and bottom of the hinge using #8 self tapping screws and tighten the screws to 10 lb-in (113 N-cm) and not to exceed 2500 rpm. See [Fig. 4](#) and [Fig. 5](#)

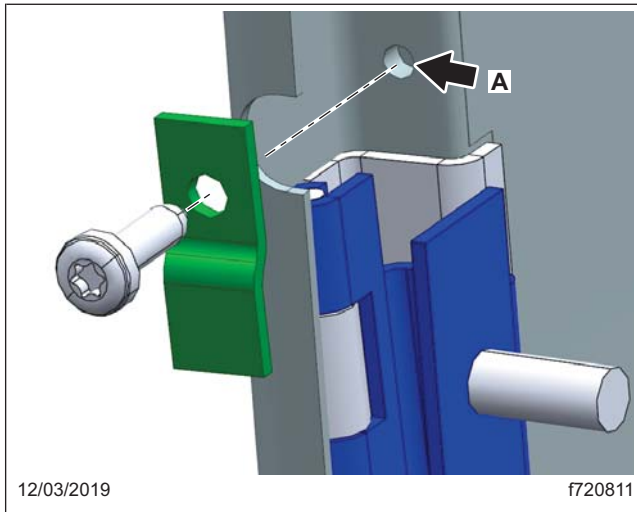

**Fig. 4, Hinge Reinforcement Assembly**



**Fig. 5, Installed Hinge Clip Showing Screw**

10. Touch up trimmed edges with paint in the closest matching color available and allow to dry.
11. Install the door onto the vehicle.
- For sleeper door installation instructions refer to **Section 72.02, Subject 100** in the *Western Star Workshop Manual*.
  - For baggage door installation instructions refer to **Section 72.01, Subject 110** in the *Western Star Workshop Manual*.
12. Clean a spot on the base label (Form WAR259). Write the campaign number FL834 on a blank red completion sticker (Form WAR260). Attach the sticker to the base label to indicate the work has been completed.

## Door Hinge Screw Replacement (FL834D, E, and F)

**IMPORTANT:** Perform this procedure on vehicles that had the INT FL834 repair completed. The produce details the swapping out of new screws for the self-tapping screws used in the interim recall.

**NOTE:** An FL834 completion sticker may not be a good indication that the final repair has been completed as some dealers may have installed a sticker during the INT FL834 interim repair.

1. Check the Coverage Info screen in OWL for an FL834 "final" repair claim indicating this work has been done. If a claim is present, no work is needed. If there is no claim, proceed with the next step.
2. Park the vehicle on a flat surface, set the parking brake, shut down the engine. Chock the tires.



August 2020  
FL834A-F  
NHTSA #19V-722  
Transport Canada #19-508

3. Open and remove the baggage or sleeper doors.
  - For sleeper door removal instructions refer to **Section 72.02, Subject 100** in the *Western Star Workshop Manual*.
  - For baggage door removal instructions refer to **Section 72.01, Subject 110** in the *Western Star Workshop Manual*.
4. On each door, remove the screw installed during the interim recall. See **Fig. 5**.



**Fig. 5, Installed Hinge Clip Showing Screw**

5. On each door, install the new screw (part number 23-14673-705), tightening it to 10 lb-in (113 N-cm).
6. Install each door onto the vehicle.
  - For sleeper door installation instructions refer to **Section 72.02, Subject 100** in the *Western Star Workshop Manual*.
  - For baggage door installation instructions refer to **Section 72.01, Subject 110** in the *Western Star Workshop Manual*.
7. Clean a spot on the base label (Form WAR259). Write the campaign number FL834 on a blank red completion sticker (Form WAR260). Attach the sticker to the base label to indicate the work has been completed.