

Recall Campaign

Daimler Trucks
North America LLC

June 2020
FL832A
NHTSA #19V-712
Transport Canada #2019-497

Subject: TBB SynTec S3B/S3C Seat Kneeforms

Models Affected: Specific Model Year 2015-2020 Thomas Built Buses Minotour and Saf-T-Liner C2, EFX, and HDX model school buses manufactured August 18, 2014, through August 15, 2019, with certain SynTec S3B or S3C seats.

General Information

Daimler Trucks North America LLC (DTNA), on behalf of its wholly owned subsidiary, Thomas Built Buses (TBB), has decided that a defect that relates to motor vehicle safety exists on the vehicles mentioned above.

There are approximately 57,000 vehicles involved in this campaign.

On certain buses equipped with affected seats, specific areas of the seat back may not meet the requirements of FMVSS 222, part 53.3.2, *School Bus Seating and Crash Protection*. This may increase the risk of injury to occupants in a crash.

Seats will be augmented by installation of additional impact material between the seat back and the back cover to assure compliance with pertinent requirements.

Additional Repairs

Dealers must complete all outstanding Recall and Field Service campaigns prior to the sale or delivery of a vehicle. A Dealer will be liable for any progressive damage that results from its failure to complete campaigns before sale or delivery of a vehicle.

Owners may be liable for any progressive damage that results from failure to complete campaigns within a reasonable time after receiving notification.

Work Instructions

Please refer to the attached work instructions.

Replacement Parts

Selling dealers were proactively shipped an estimated 40 percent of the parts needed to complete the buses sold by the dealership. Parts and the optional installation tool for this repair, see **Table 1**, may also be ordered at no charge by following the instructions below.

Ordering Instructions

Email Address: tbbseatrecall@daimler.com

Subject line: Recall FL832 Parts Order

Include in email:

- Quantity ordered
- Dealer name and dealer code
- Contact person and phone number
- Shipping address

Recall Campaign

Daimler Trucks
North America LLC

June 2020
FL832A
NHTSA #19V-712
Transport Canada #2019-497

Table 1 –Parts for FL832

Campaign Number	Part Number	Description	Qty. Per Seat
FL832A	TBB 223749	SYNTEC POLYPROPYLENE FF INSERT (2 PER SEAT REQUIRED)	2 ea
	N/A	STAPLES	As needed
	N/A	OPTIONAL INSTALLATION TOOL (1 PER DEALERSHIP)	1 ea (use for all buses)

Table 1

Removed Parts

Please follow Warranty Failed Parts Tracking shipping instructions for the disposition of all removed parts.

Labor Allowance

Table 2 – Labor Allowance

Campaign Number	Procedure	Time Allowed (Hours)	SRT Code	Corrective Action
FL832A	Add foam insert to 1-5 seats	0.5	996-R196A	12 – Repair Recall/Campaign
	Add foam insert to 6-10 seats	0.8	996-R196B	
	Add foam insert to 11-15 seats	1.4	996-R196C	
	Add foam insert to 16-20 seats	2.3	996-R196D	
	Add foam insert to 21-25 seats	2.7	996-R196E	
	Add foam insert to 26-30 seats	2.8	996-R196F	

Table 2

Recall Campaign

Daimler Trucks
North America LLC

June 2020

FL832A

NHTSA #19V-712

Transport Canada #2019-497

Claims for Credit

You will be reimbursed for your parts, labor, and handling by submitting your claim through the Warranty system within 30 days of completing this campaign. Please reference the following information in OWL:

- Claim Type is **Recall Campaign**.
- In the Campaign field, enter the campaign number (**FL832-A**).
- In the Primary Failed Part field, enter **25-FL832-000**.
- In the Parts section, enter staples as miscellaneous parts as needed. The polypropylene foam inserts **are not listed** on the claim and are provided at no charge.
- In the Labor section, enter the appropriate SRT from the Labor Allowance Table. Claim the SRT that includes the number of seats repaired.
- The VMRS Component Code is **F99-999-005** and the Cause Code is **A1 - Campaign**.
- **U.S. and Canada – Reimbursement for Prior Repairs**. When a customer asks about reimbursement, please do the following:
 - Accept the documentation of the previous repair.
 - Make a brief check of the customer's paperwork to see if the repair may be eligible for reimbursement.
 - Submit a Recall Pre-Approval request for a decision and authorized amount.
 - Submit a "based on" claim for the approved pre-approval.
 - Attach the documentation to the pre-approval request.
 - When your claim is paid, reimburse the customer the appropriate amount.

IMPORTANT: OWL must be viewed prior to performing the recall to ensure the vehicle is involved and the campaign has not been previously completed.

If you have any questions or need additional information, contact the Warranty Campaigns Department via Web inquiry at DTNACconnect.com / WSC.

Excess kit inventory related to this campaign is not returnable.

A sample letter notifying vehicle owners is included for your reference.

Please note that the National Traffic and Motor Vehicle Safety Act, as amended (Title 49, United States Code, Chapter 301), requires the owner's vehicle(s) be corrected within a reasonable time after parts are available to you. The Act states that failure to repair a vehicle within 60 days after tender for repair shall be prima facie evidence of an unreasonable time. However, circumstances of a particular situation may reduce the 60 day period. Failure to repair a vehicle within a reasonable time can result in either the obligation to (a) replace the vehicle with an identical or reasonably equivalent vehicle, without charge, or (b) refund the purchase price in full, less a reasonable allowance for depreciation. The Act further prohibits dealers from selling a vehicle unless all outstanding recalls are performed. Any lessor is required to send a copy of the recall notification to the lessee within 10 days. Any subsequent stage manufacturer is required to forward this notice to its distributors and retail outlets within five working days.

Recall Campaign

Daimler Trucks
North America LLC

June 2020
FL832A
NHTSA #19V-712
Transport Canada #2019-497

Copy of Notice to Owners

Subject: TBB SynTec S3B/S3C Seat Kneeforms

The U.S. notice is used for reference: This notice is sent to you in accordance with the requirements of the *National Traffic and Motor Vehicle Safety Act*.

Daimler Trucks North America LLC, on behalf of its wholly owned subsidiary, Thomas Built Buses, has decided that a defect which relates to motor vehicle safety exists on specific Model Year 2015-2020 Thomas Built Buses Minotour and Saf-T-Liner C2, EFX, and HDX model school buses manufactured August 18, 2014, through August 15, 2019, with certain SynTec S3B or S3C seats.

On certain buses equipped with affected seats, specific areas of the seat back may not meet the requirements of FMVSS 222, part 53.3.2, *School Bus Seating and Crash Protection*. This may increase the risk of injury to occupants in a crash.

Seats will be augmented by installation of additional impact material between the seat back and the back cover to assure compliance with pertinent requirements.

This is the second letter regarding this recall to let you know the repair is now available. **To arrange for repairs, you should contact your local Thomas Built Buses dealer immediately.** The repair may take up to three hours, depending on the number of seats affected, and will be performed at no charge to you.

You may be liable for any progressive damage that results from your failure to complete the Recall within a reasonable time after receiving notification.

If you do not own the vehicle that corresponds to the identification number(s) which appears on the Recall Notification, please return the notification to the Warranty Campaigns Department with any information you can furnish that will assist us in locating the present owner. If you have leased this vehicle, Federal law requires that you forward this notice to the lessee within 10 days. If you are a subsequent stage manufacturer, Federal law requires that you forward this notice to your distributors and retail outlets within five working days. If you have paid to have this recall condition corrected prior to this notice, you may be eligible to receive reimbursement. Please see the reverse side of this notice for details.

If you have any questions about this recall, please contact the Warranty Campaigns Department at (800) 547-0712, 7:00 a.m to 4:00 p.m, Monday through Friday. If you are not able to have the defect remedied without charge and within a reasonable time, you may wish to submit a complaint to the Administrator, National Highway Traffic Safety Administration, 1200 New Jersey Avenue, SE, Washington, DC 20590; or call the Vehicle Safety Hotline at (888) 327-4236 (TTY: 800-424-9153); or to <http://www.safercar.gov>

We regret any inconvenience this action may cause but feel certain you understand our interest in motor vehicle safety.

THOMAS BUILT BUSES WARRANTY DEPARTMENT
Enclosure

Recall Campaign

Daimler Trucks
North America LLC

June 2020

FL832A

NHTSA #19V-712

Transport Canada #2019-497

Reimbursement to Customers for Repairs Performed Prior to Recall

If you have already **paid** to have this recall condition corrected you may be eligible to receive reimbursement.

Requests for reimbursement may include parts and labor. Reimbursement may be limited to the amount the repair would have cost if completed by an authorized Daimler Trucks North America LLC dealer. The following documentation must be presented to your dealer for consideration for reimbursement.

Please provide original or clear copies of all receipts, invoices, and repair orders that show:

- The name and address of the person who paid for the repair.
- The Vehicle Identification Number (VIN) of the vehicle that was repaired.
- What problem occurred, what repair was done, when the repair was done.
- Who repaired the vehicle.
- The total cost of the repair expense that is being claimed.
- Proof of payment for the repair (such as the front and back of a cancelled check or a credit card receipt).

Reimbursement will be made by check from your Daimler Trucks North America LLC dealer.

Please speak with your Thomas Built Buses authorized dealer concerning this matter.

Recall Campaign

Daimler Trucks
North America LLC

June 2020
FL832A
NHTSA #19V-712
Transport Canada #2019-497

Work Instructions

Subject: TBB SynTec S3B/S3C Seat Kneeforms

Models Affected: Specific Model Year 2015-2020 Thomas Built Buses Minotour and Saf-T-Liner C2, EFX, and HDX model school buses manufactured August 18, 2014, through August 15, 2019, with certain SynTec S3B or S3C seats.

Impact Material (Foam Insert) Installation

1. Park the vehicle on a level surface, turn the key completely off, put the bus in Park, and set the parking brake. Chock the tires.
2. Wearing safety glasses and gloves, release the finger latch on the bottom of the seat and tilt forward and out of the way. Remove the bottom seat cushion and set aside.
3. Using a staple remover, remove the staples from the first 3 to 6 inches on both sides of the seat (wall and aisle sides) of the seat. See **Figure 1**.

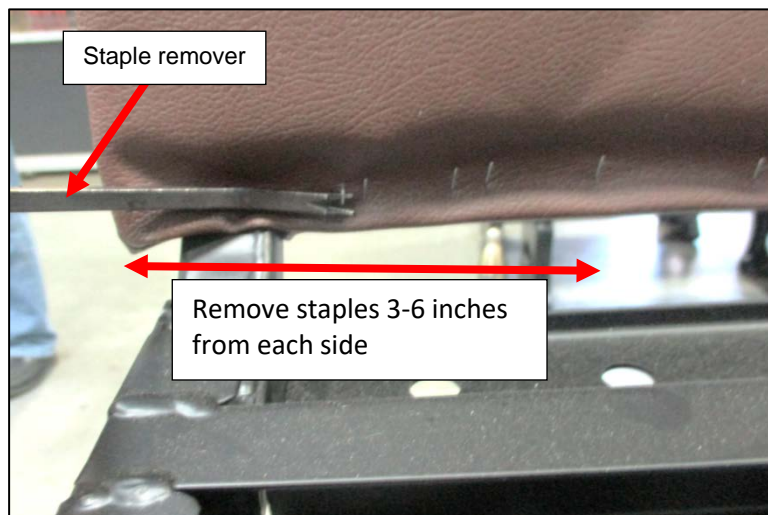

Figure 1: Removing the Vinyl Seat Cover

4. Pull the remaining vinyl out by hand, to detach the remaining staples and reveal the reverse side of the stapled vinyl.

Recall Campaign

Daimler Trucks
North America LLC

June 2020

FL832A

NHTSA #19V-712

Transport Canada #2019-497

5. From the front of the seat, using a staple remover or wide-nose pliers, remove the staples from the reverse side of the vinyl. See **Figure 2**.



Figure 2: Removing Staples from the Reverse Side of the Vinyl

6. Using pliers, bend all staples shown in **Figure 3** to ensure there are no sharp points. This will be covered with two layers of vinyl in later steps.



Figure 3: Remove Staples from Wood Strip

IMPORTANT: In steps 9 and 10, do not pull the cover completely off the seat back.

7. Pull or roll the vinyl cover up on the front of the seat. See **Figure 4**.

Recall Campaign

June 2020
FL832A
NHTSA #19V-712
Transport Canada #2019-497

8. Pull or roll the cover up on the seat back. See **Figure 5**.

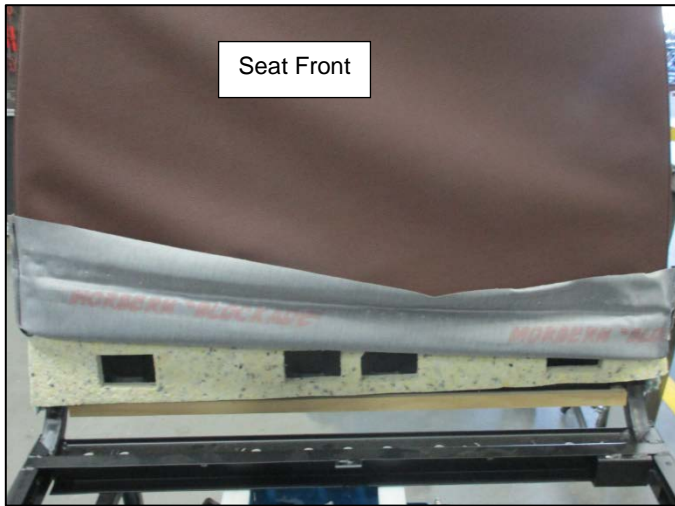

Figure 4: Cushion and Vinyl Cover (Seat Front)

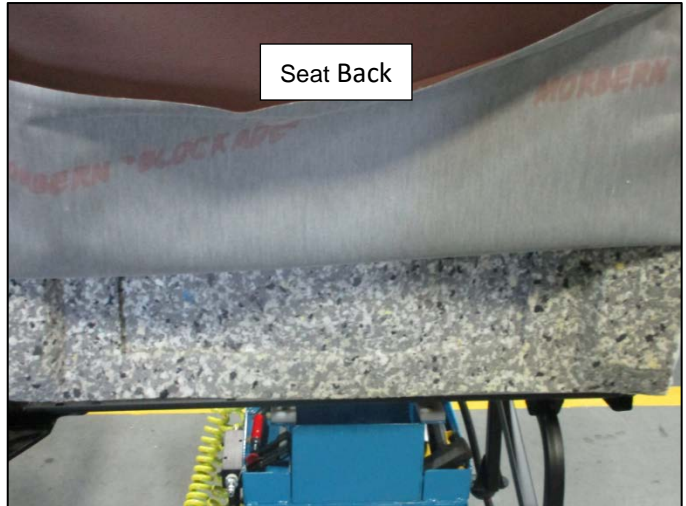

Figure 5: Vinyl Cover (Seat Back)

NOTE: An optional tool, provided with new impact material inserts ("insert") shipped to dealers, may be used. It slides up with the insert between the existing foam and the vinyl cover. Once in position, slide the tool out.

9. Place the Insert between the vinyl and the existing foam. The narrower side of the insert is positioned toward the side of the seat and the wider side is positioned toward the back of the seat. See **Figure 6**, **Figure 7**, and **Figure 8**.



Figure 6: Positioning the Insert

Recall Campaign

Daimler Trucks
North America LLC

June 2020
FL832A
NHTSA #19V-712
Transport Canada #2019-497



Figure 7: Insert Installed

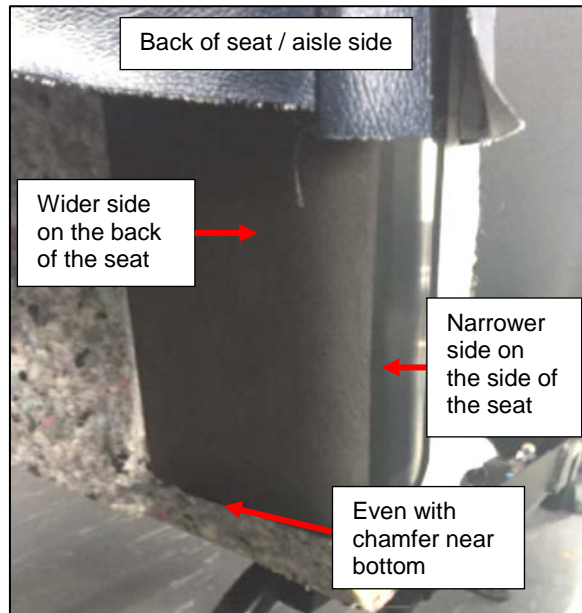

Figure 8: Insert During Installation

10. After both inserts are in place between the vinyl and foam, make sure the top edge of the foam has not folded over. Flatten the top edge of the foam by hand or slide the tool up to smooth any rolls, if required. Then, pull the vinyl down over the repair on both sides evenly. Do not pull one side down then the other, pull down both sides at the same time.
11. Check the bottom edge of both inserts. They should remain even with the foam chamfer, approximately 2 inches from the bottom of the foam. If either insert has shifted, adjust as necessary by sliding it up or down as needed to maintain the 2-inch distance from the bottom of the foam. See **Figure 9**.

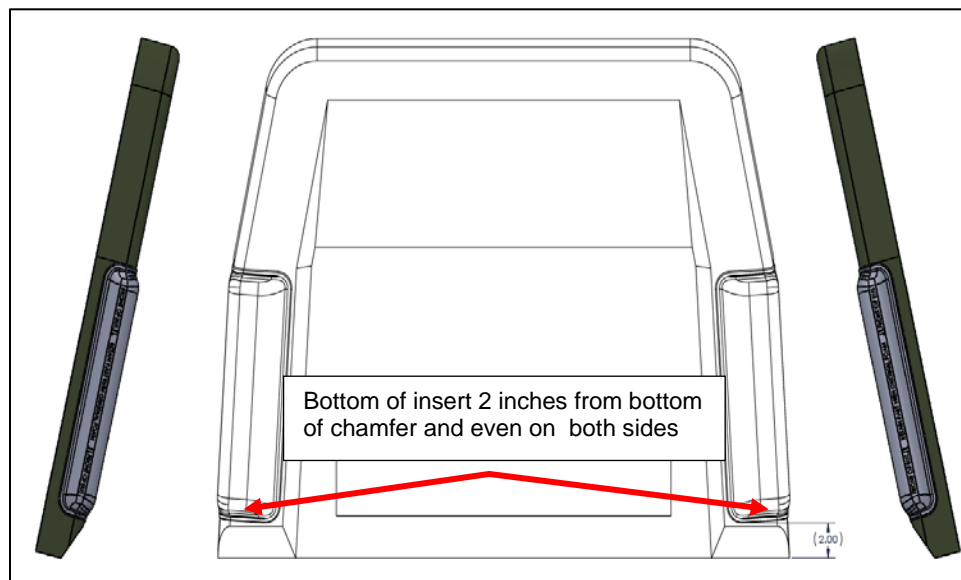

Figure 9: Alignment with Seat Foam

Recall Campaign

Daimler Trucks
North America LLC

June 2020

FL832A

NHTSA #19V-712

Transport Canada #2019-497

12. Tuck and fold the front and back corners of the seat cover around the rear seat leg. See **Figure 10**.



Figure 10: Folding and Tucking the Vinyl Seat Cover

13. Pull the vinyl cover on the back of the seat under the seat and pull tight. Staple to the original wood strip. See **Figure 3**, **Figure 11**, and **Figure 12**.



Figure 11: Staple Back of Vinyl Seat Cover onto the Wood Strip

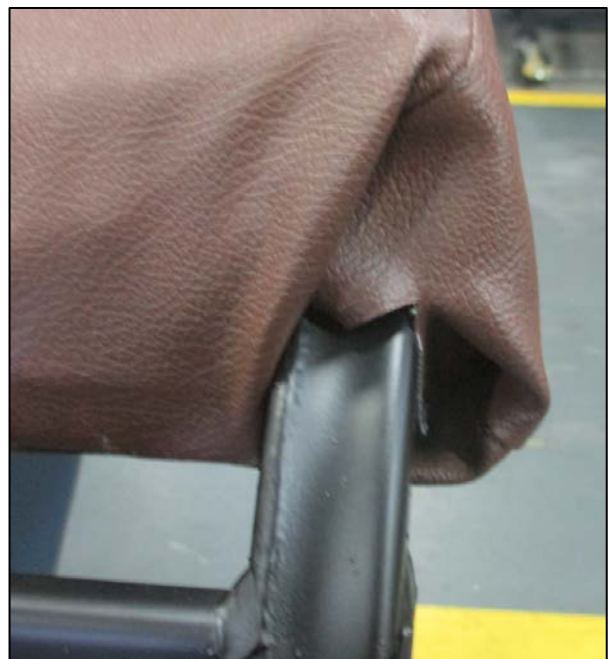

Figure 12: After Cover is Folded and Stapled

Recall Campaign

Daimler Trucks
North America LLC

June 2020

FL832A

NHTSA #19V-712

Transport Canada #2019-497

14. Pull the vinyl cover on the front of the seat down. Make sure it is straight and there are no wrinkles.
15. Fold the vinyl underneath itself to match the crease from the original installation.
16. Staple the front vinyl cover to the wood strip (that it was removed from earlier). Ensure no restraint belts are obstructed by the vinyl or staples. See **Figure 13**.



Figure 13: Front Seat Cover When Folded and Stapled

17. Reinstall the seat cushion removed earlier.
18. Remove the chocks from the tires.