



Southeast Toyota Distributors, LLC

Attention

This is an important Safety Recall which was initiated by Southeast Toyota Distributors, LLC.

If you are in Florida, Georgia, Alabama, South Carolina, or North Carolina, please refer to SET Dealer Daily to obtain instructions on how to complete this repair and submit a warranty claim.

Toyota Dealerships outside of Florida, Georgia, Alabama, South Carolina or North Carolina

SET will reimburse you for the repairs outlined in the following procedure. For repair authorization and parts ordering, please contact Southeast Toyota Distributors, LLC toll free at 1-888-851-2722, or email oordealersupport@setoyota.com.

Thank you for your continued support.

Southeast Toyota Distributors, LLC

TECHNICAL INSTRUCTIONS
FOR
VOLUNTARY SAFETY RECALL CAMPAIGN SET19B
TORQUE VERIFICATION ON VARIOUS COMPONENTS
CERTAIN 2018-2019 MODEL YEAR 4RUNNER

All dealership technicians performing this recall are required to successfully complete the most current version of E-Learning course “Safety Recall and Service Campaign Essentials”. To ensure that all vehicles have the repair performed correctly; technicians performing this recall are required to have successfully completed E-learning course SC18A (if you had previously completed E-learning Course SC13B, you do not have to take SC18A), in addition to “Safety Recall and Service Campaign Essentials”, and currently hold at least one of the following certification levels:

- Toyota Expert
- Master
- Master Diagnostic Technicians

OPERATION FLOW CHART

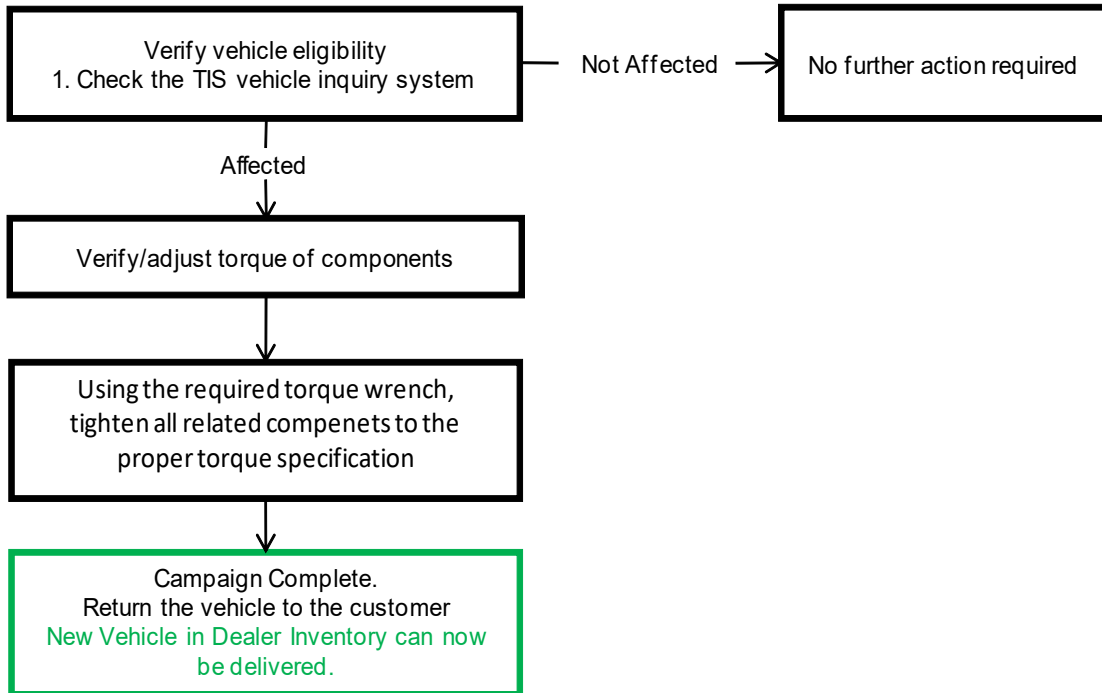

IDENTIFICATION OF AFFECTED VEHICLES

NOTE:

- Check the TIS Vehicle Inquiry System to confirm the VIN is involved in this SSC and that the campaign has not already been completed prior to dealer shipment or by another dealer.
- **Southeast Toyota warranty will not reimburse dealers for repairs conducted on vehicles that are not affected or were completed by another dealer.**

PREPARATION

A. PARTS

None required

B. TOOLS & EQUIPMENT

1. Digital Torque wrench
2. Standard hand tools

BACKGROUND

SET’s investigation found that a specific model of Atlas Copco Torque wrench utilized in the 4Runner accessory line was failing to consistently upload the torque data to the Atlas Copco system due to poor Wi-Fi connectivity at the Talleyrand facility. This recall is to confirm that accessories installed with this torque wrench were properly torqued to the installation specifications.

WARRANTY INFORMATION

For Dealers located in the Southeast Region, Florida, Georgia, Alabama, South Carolina, or North Carolina, Submit Warranty claim utilizing the information below.

OP CODE	DESCRIPTION	TIME	OFF	T1	T2
AR19B1	Accessory Torque Validation	2.0	00016-SPECL	99	99
<i>Additional Claim information:</i>					
Replacement Parts:	N/A, leave blank				
Sublet:	N/A, leave blank				
Condition:	SET19B				
Cause:	SET19B				
Remedy:	Perform Torque Validation				
Claim Attachment:	<u>SET19B Torque Validation Form must be attached to AW CPS claim.</u>				

The flat rate times include 0.1 hours for administrative cost per unit for the dealership.

If you are a dealer located outside of the Southeast Region, email oordealersupport@setoyota.com attach copy of RO invoice for payment processing.

WORK PROCEDURE

Note: SET19B Instructions outline a process which requires the SET19B Torque Validation Form located at the end of this document be completed. SET requests this form be scanned and attached to the SET warranty claim.

1. Lift vehicle on suitable hoist.
2. Remove Tire and Wheel assemblies from vehicle.
3. Remove TRD skid plate from front of vehicle. (Fig. 1)
 - a. Use a 14mm socket to remove the two rear bolts and loosen the two front bolts attached to the Skid Plate. Remove the Skid Plate and retain it and the bolts for reinstallation.

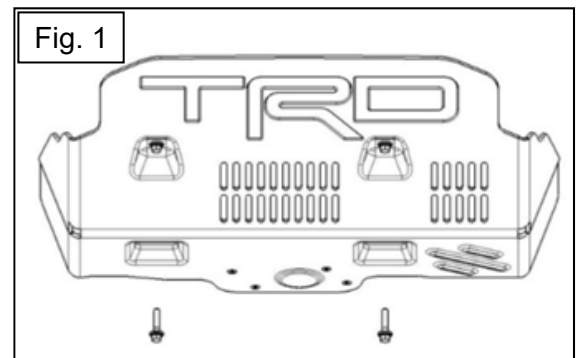

4. Verify torque of left and right side Upper Shock Nuts, Items A1-A6 on SET19B Torque form.

- a. Use a 14mm crowfoot to torque the nuts on the upper side of the front shock absorber with coil spring assembly (Refer to Fig. 2).
- b. Set torque wrench higher than upper range limit.
- c. Slowly apply torque until the fastener starts to rotate.
- d. Document reading on SET19B Torque form under initial values.
- e. *If any measurement is out of specified range: loosen, re-torque to specified value. Record values on SET19B torque form.*

- Torque, with crowfoot:
 - **Range: 56-93 N·m (41-69 ft·lbf)**
 - **Specified: 65 N·m (663 kgf·cm, 48 ft·lbf)**
- Torque, without crowfoot:
 - **Range: 62-102 N·m (46-75 ft·lbf)**
 - **Specified: 71 N·m (724 kgf·cm, 52 ft·lbf)**

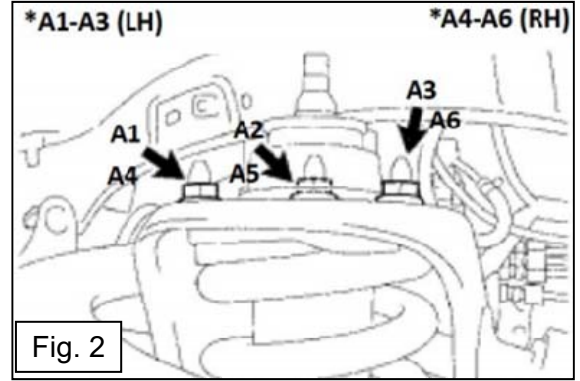

5. Verify torque of the left and right lower ball joint attachment bolts (Fig. 3). Items B1-B4 on SET19B Torque form.

- a. Use a 19mm socket to torque bolts.
- b. Set torque wrench higher than upper range limit.
- c. Slowly apply torque until the fastener starts to rotate.
- d. Document reading on SET19B Torque form under initial values.
- e. *If any measurement is out of specified range: loosen, re-torque to specified value. Record values on SET19B torque form.*

- **Torque:**
 - **Range: 139-229 N·m (103-169 ft·lbf)**
 - **Specified: 160 N·m (1631 kgf·cm, 118 ft·lbf)**

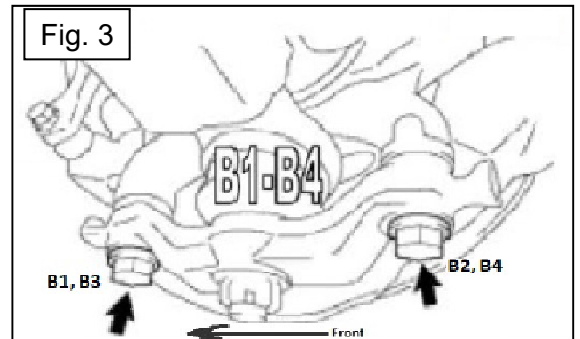

6. Verify torque of left and right side front lower control arm Bolts (Fig. 4) Items C1-C4 on SET19B Torque Form.

- a. Use a 22mm socket to torque the front and rear lower control arm bolts (Fig. 8-2).
- b. Set torque wrench higher than upper range limit.
- c. Slowly apply torque until the fastener starts to rotate.
- d. Document reading on SET19B Torque form under initial values.
- e. *If any measurement is out of specified range: loosen, re-torque to specified value. Record values on SET19B torque form.*

- **Torque:**
 - **Range: 152-251 N·m (112-185 ft·lbf)**
 - **Specified: 175 N·m (1785 kgf·cm, 129 ft·lbf)**

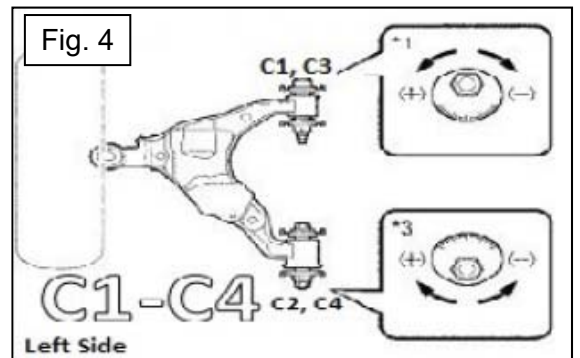

7. Verify Torque of driver side and passenger side tie rod end locking nuts. (Fig. 5) Items D1 and D2 on SET19B Torque Form.

- a. Use a 22mm crowfoot to torque the front and rear lower control arm bolts.
- b. Set torque wrench higher than upper range limit.
- c. Slowly apply torque until the fastener starts to rotate.
- d. Document reading on SET19B Torque form under initial values.
- e. *If any measurement is out of specified range: loosen, re-torque to specified value. Record values on SET19B torque form.*

- **Torque:**
 - **Range: 76-126 N·m (56-93 ft·lbf)**
 - **Specified: 88 N·m (897 kgf·cm, 65 ft·lbf)**

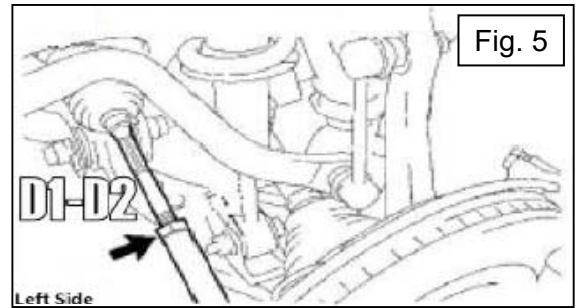

Fig. 5

8. Verify Torque of driver side and passenger side front lower shock bolts. (Fig. 6) Items E1 and E2 on torque Form.

- a. Use a 19mm wrench and 19mm socket to torque the front lower shock bolts.
- b. Set torque wrench higher than upper range limit.
- c. Slowly apply torque until the fastener starts to rotate.
- d. Document reading on SET19B Torque form under initial values.
- e. *If any measurement is out of specified range: loosen, re-torque to specified value. Record values on SET19B torque form.*

- **Torque:**
 - **Range: 82-136 N·m (61-100 ft·lbf)**
 - **Specified: 95 N·m (969 kgf·cm, 70 ft·lbf)**

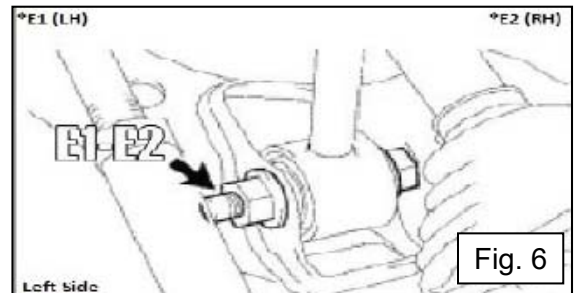

Fig. 6

9. Reinstall TRD skid plate and verify Torque. (Fig. 7)

- a. Use a 14mm wrench torque the front lower shock bolts.
 - **Torque: 30 N·m (306 kgf·cm, 22 ft·lbf)**
- b. Document Torque on SET19B Torque form.
 - F1-4 for skid plate

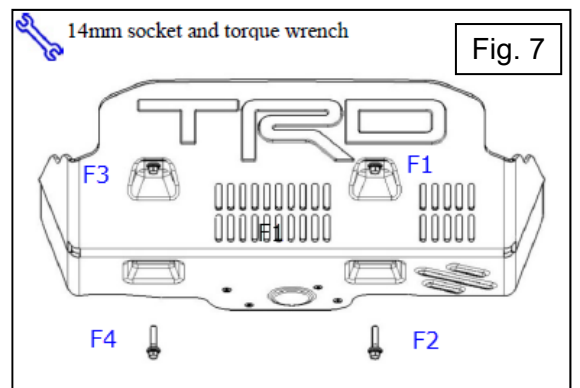
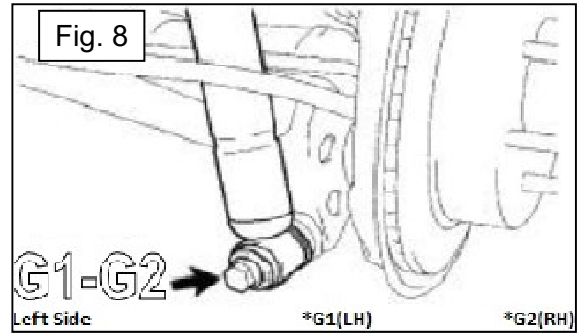

Fig. 7

10. Verify Torque of driver side and passenger Rear lower shock bolt. (Fig. 8) Items G1 and G2 on torque Form.

- a. Use a 19mm socket to torque the front lower shock bolts.
- b. Set torque wrench higher than upper range limit.
- c. Slowly apply torque until the fastener starts to rotate.
- d. Document reading on SET19B Torque form under initial values.
- e. *If any measurement is out of specified range: loosen, re-torque to specified value. Record values on SET19B torque form.*

- **Torque:**
 - **Range: 82-136 N·m (61-100 ft·lbf)**
 - **Specified: 98 N·m (1000 kgf·cm, 72 ft·lbf)**



11. Reinstall tire and wheel assemblies (Fig. 9)

- a. Torque lug nuts to specification
 - **Torque: 103 N·m (76 ft·lbf)**
- b. Document Lug Nut Torque on Torque record form.

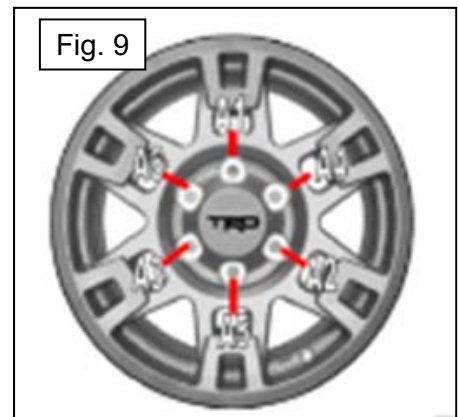

12. Review Torque form to verify completion.

- a. Dealer should retain a copy with the RO.
- b. Torque form must be attached to warranty claim submitted to SET.

APPENDIX

A. CAMPAIGN DESIGNATION DECODER

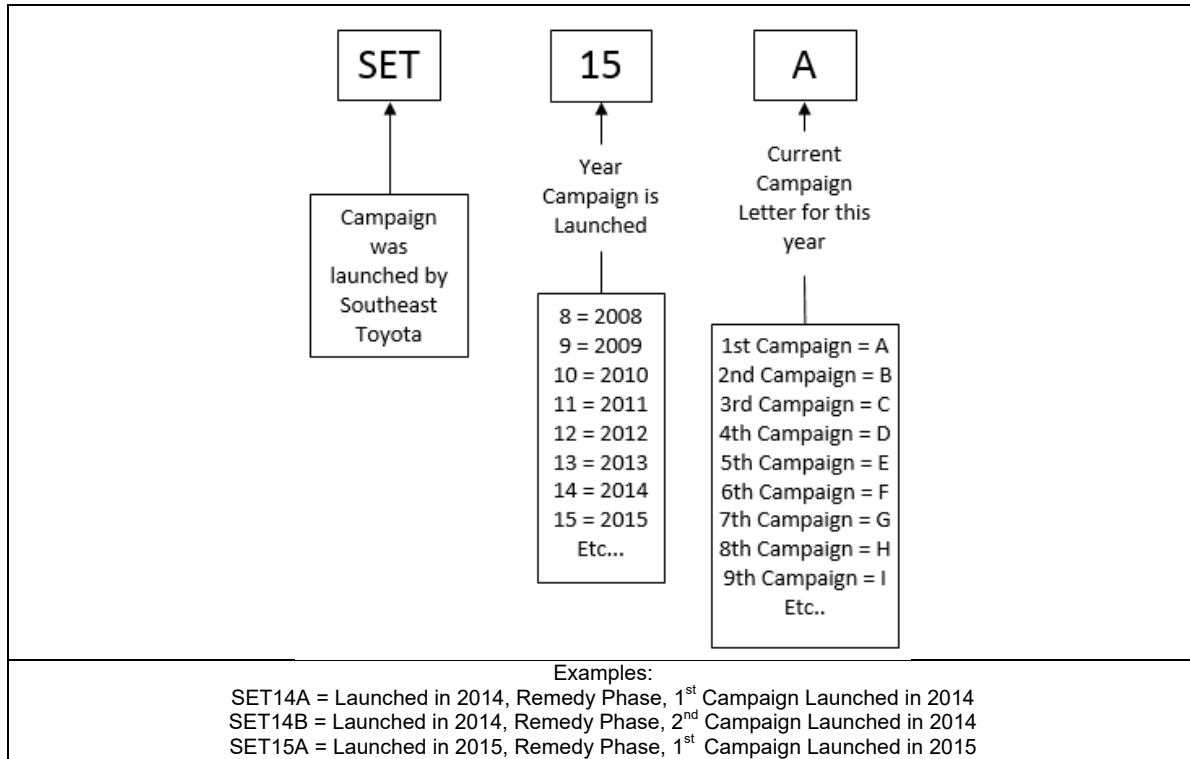

SET19B Torque Validation Form

VIN:

FRONT UPPER SHOCK NUTS

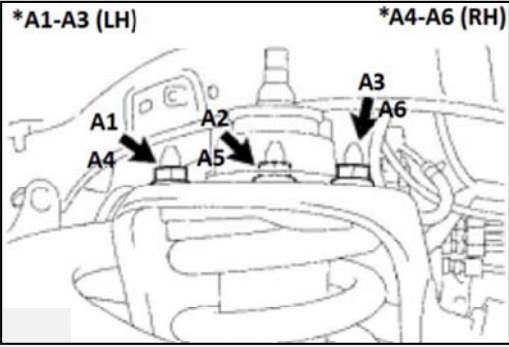

LEFT SIDE		RIGHT SIDE	
Initial Value	Re-torque Value	Initial Value	Re-torque Value
A1:		A4:	
A2:		A5:	
A3:		A6:	

Note: "Re-torque Value" is only needed if the "Initial Value" is out of the range:

- With Crowfoot: **56-93 N-m (41-69 ft-lbf)**
- Without Crowfoot: **62-102 N-m (46-75 ft-lbf)**

LOWER BALL JOINT ATTACHMENT BOLTS

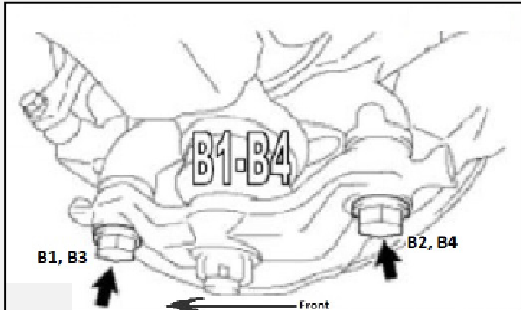

LEFT SIDE		RIGHT SIDE	
Initial Value	Re-torque Value	Initial Value	Re-torque Value
B1:		B3:	
B2:		B4:	

Note: "Re-torque Value" is only needed if the "Initial Value" is out of the range:

- **139-229 N-m (103-169 ft-lbf)**

LOWER CONTROL ARM BOLTS

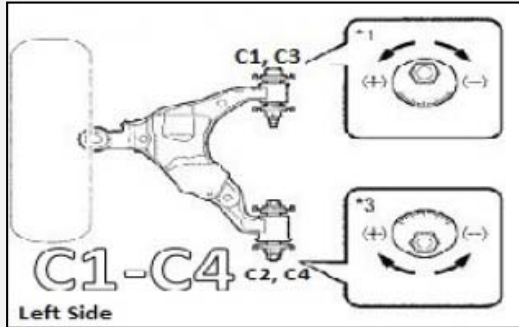

LEFT SIDE		RIGHT SIDE	
Initial Value	Re-torque Value	Initial Value	Re-torque Value
C1:		C3:	
C2:		C4:	

Note: "Re-torque Value" is only needed if the "Initial Value" is out of the range:

- **152-251 N-m (112-185 ft-lbf)**

TIE ROD END LOCKING NUT

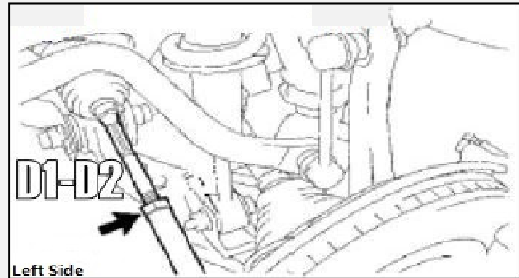

LEFT SIDE		RIGHT SIDE	
Initial Value	Re-torque Value	Initial Value	Re-torque Value
D1:		D2:	

Note: "Re-torque Value" is only needed if the "Initial Value" is out of the range:

- **76-126 N-m (56-93 ft-lbf)**

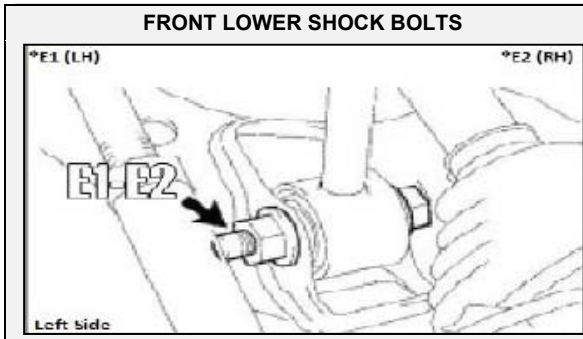

LEFT SIDE		RIGHT SIDE	
Initial Value	Re-torque Value	Initial Value	Re-torque Value
E1:		E2:	

Note: "Re-torque Value" is only needed if the "Initial Value" is out of the range:
 • **82-136 N-m (61-100 ft-lbf)**

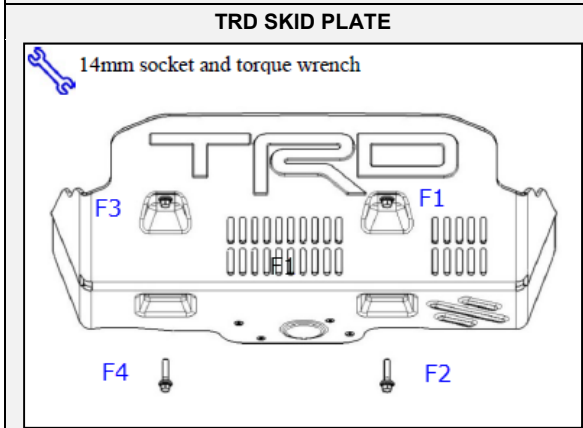

LEFT SIDE		RIGHT SIDE	
Torque Value		Torque Value	
F1:		F3:	
F2:		F4:	

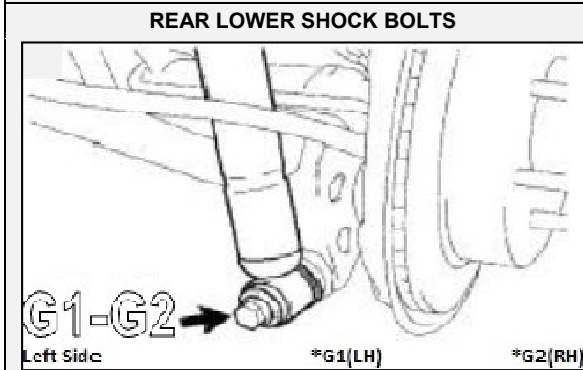

LEFT SIDE		RIGHT SIDE	
Initial Value	Re-torque Value	Initial Value	Re-torque Value
G1:		G2:	

Note: "Re-torque Value" is only needed if the "Initial Value" is out of the range:
 • **Range: 82-136 N-m (61-100 ft-lbf)**

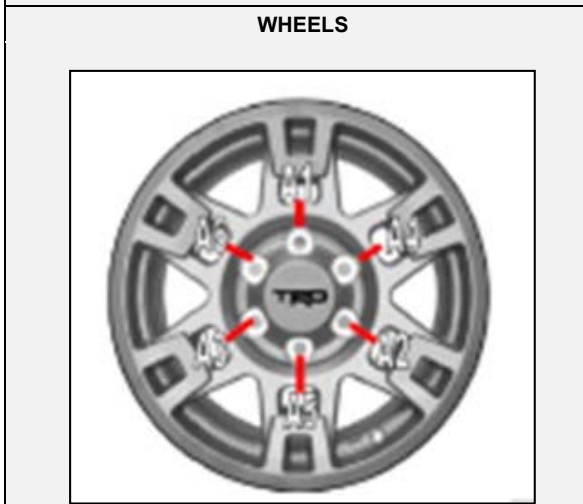

LEFT SIDE		RIGHT SIDE	
Left Front	Left Rear	Right Front	Right Rear