

TECHNICAL INSTRUCTIONS
FOR
SAFETY RECALL K0Q
FRONT PASSENGER AIRBAG “MODULE” REPLACEMENT ONLY



CERTAIN 2005 – 2008 MODEL YEAR MATRIX

Updated 3/5/2021

Update 3/5/2021

- The replacement airbag assembly part number has changed for the Continental U.S. 48 States Only.
- The note regarding new airbag assembly boxes requiring checkmarks has been removed.

Update 6/9/2020

- A note was added to clarify scanning new airbag assemblies.
- A note was added to instruct not to open new airbag assembly boxes without confirming the checkmark is present.

All dealership technicians performing this recall are required to successfully complete the most current version of the E-Learning course “Safety Recall and Service Campaign Essentials”. To ensure that all vehicles have the repair performed correctly; technicians performing this recall repair are required to have successfully completed E-Learning course SC18A (if you had previously completed E-Learning Course SC13B, you do not have to take SC18A), in addition to “Safety Recall and Service Campaign Essentials”, and currently hold at least one of the following certifications levels:

- Toyota Certified (Electrical)
- Toyota Expert (Any Specialty)
- Master
- Master Diagnostic Technicians

It is the dealership’s responsibility to select technicians with the above certification level or greater to perform this repair. Carefully review your resources, the technician skill level, and ability before assigning technicians to this repair. It is important to consider technician days off and vacation schedules to ensure there are

properly trained technicians available to perform this repair at all times.

I. OPERATION FLOW CHART

The flow chart is for reference only. **DO NOT** use it in place of the full technical instructions. Follow **ALL** steps as outlined in the full technical instructions to confirm the campaign is completed correctly.

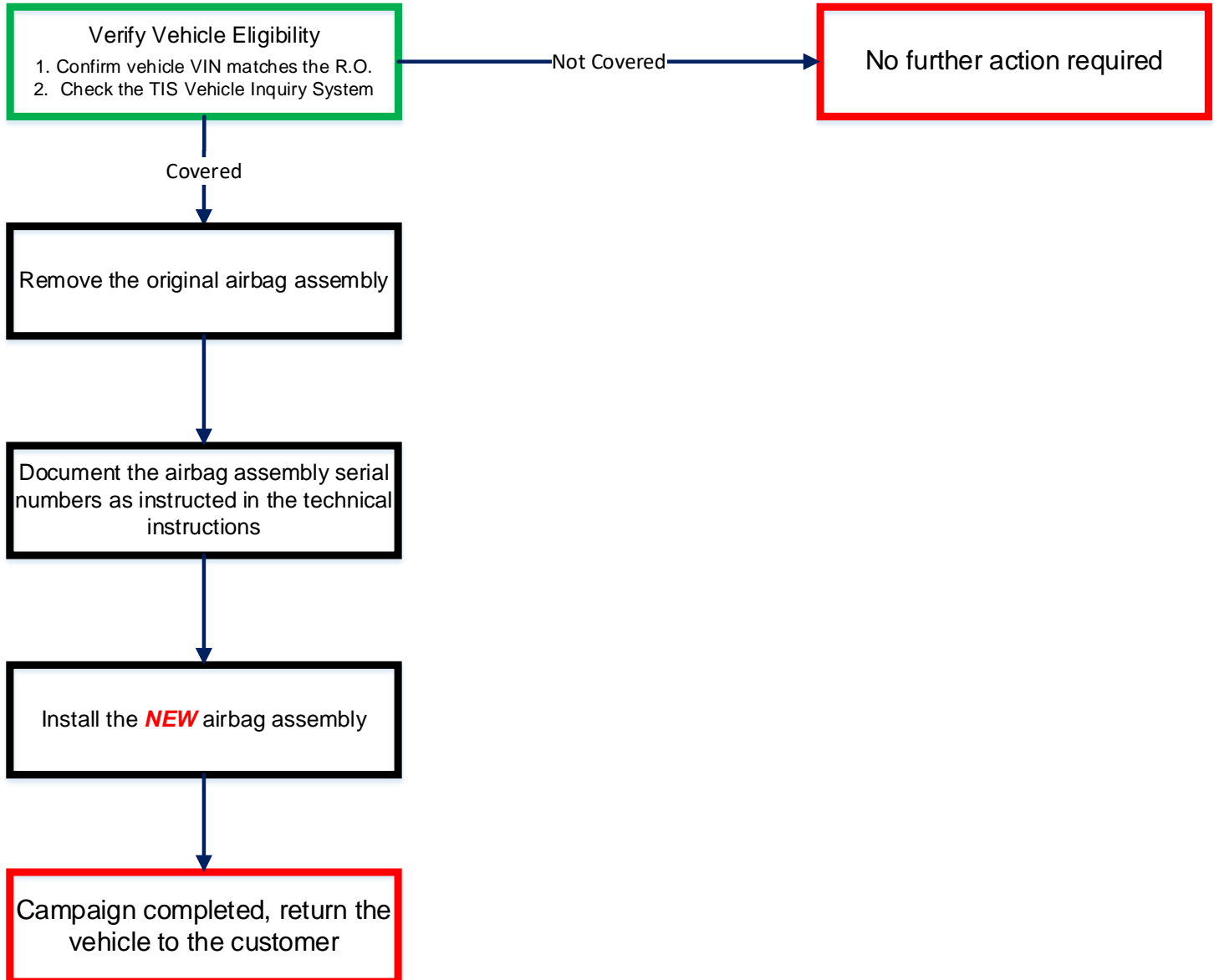

II. BACKGROUND

The subject vehicles were repaired under a prior recall. In the event of a crash that results in front passenger airbag deployment, there is a possibility that the passenger airbag could be damaged when it deploys. Such damage could cause the airbag to not properly inflate, and this could increase the risk of occupant injury in the event of a crash.

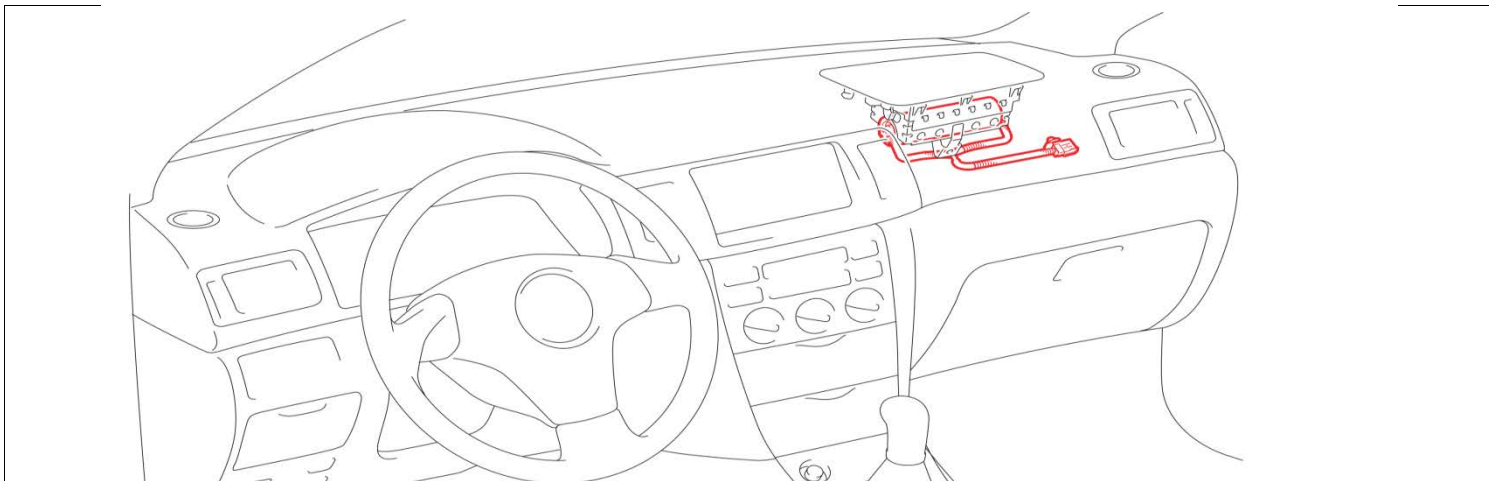

III. IDENTIFICATION OF AFFECTED VEHICLES

- Check the TIS Vehicle Inquiry System to confirm the VIN is involved in this Safety Recall, and that the campaign has not already been completed prior to dealer shipment or by another dealer.
- **TMS warranty will not reimburse dealers for repairs conducted on vehicles that are not affected or were completed by another dealer.**

IV. PREPARATION

A. PARTS

Applicable for: The Continental U.S. 48 States Only

Model	Part Number	Part Description	Quantity
05-08 Matrix	04000-20201	Instrument Panel Airbag Kit*	1
*The kit above includes the following parts.			
Airbag Module		1	

Applicable for: Alaska, Hawaii and USTT Locations Only

Model	Part Number	Part Description	Quantity
05-08 Matrix	04005-22801	Instrument Panel Airbag Kit*	1
*The kit above includes the following parts.			
Airbag Module		1	

NOTE: The Airbag Wire Harness is to be reused for the K0Q Matrix repairs

Alaska, Hawaii and USTT Locations Only

Dealers should discontinue the installation of the parts listed below for the recalls, customer pay repairs AND over-the-counter sales (if applicable) unless they have a mark on the label.



Make sure the parts box has a check mark as seen in the image above

Important Note:

In order to return the inflator, packages must NOT be opened/tampered with.

B. TOOLS & EQUIPMENT

- Standard hand tools
- Molding remover set
- Torque wrench
- Techstream

OPTIONAL SST – This is an essential special service tool that the dealership should have. This tool is not mandatory when performing this repair.

Part Number	Part Name	Quantity
09890-47010-01	Anti-Static Mat Set	1

DSF CAMPAIGN TOOLS – This tool was provided to the dealership for campaign D0F and will be used for campaign DSF. This tool is required when performing this repair.

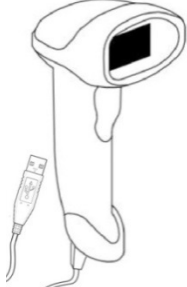
Image	Name	Quantity
	Barcode Scanner	1

NOTE: This tool **CANNOT** be ordered through the parts or tools system. There is a very limited supply of tools, but if additional tools are needed, contact your regional representative.

V. COMPONENTS

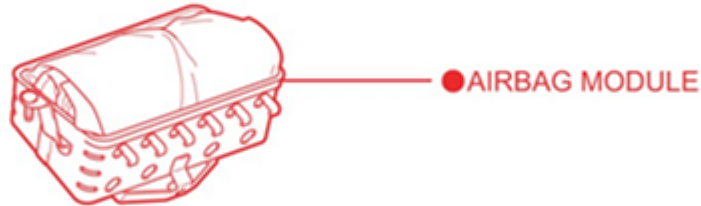

● Replacement part

R1508210003E01

VI. SAFETY PRECAUTIONS

STOP

CRITICAL INFORMATION – READ THOROUGHLY

STOP

Failure to follow these procedures correctly could cause the SRS to unexpectedly deploy during servicing or the SRS may fail to operate correctly when required after reassembly. Confirm all work is performed as described in these instructions.

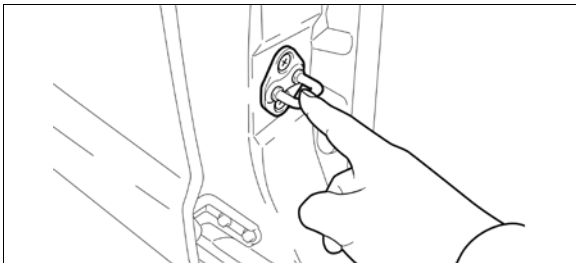

1. ELIMINATE STATIC ELECTRICITY

- a) Before starting work and periodically while working on the vehicle, touch a metallic part of the vehicle to discharge static electricity in the body.

NG DO NOT
measure resistance.

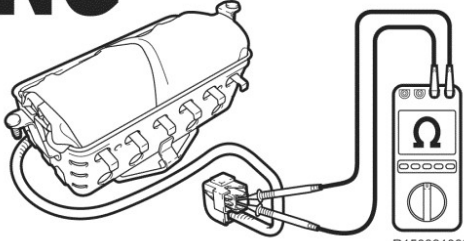

R1508210026

2. DO NOT MEASURE RESISTANCE

- a) **DO NOT** measure resistance of airbag components, this may cause accidental activation.

NG Replace with
new one.

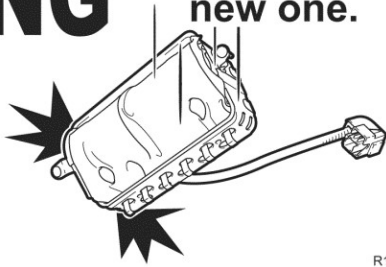

R1508210027

3. HANDLE THE AIRBAG CAREFULLY

- a) If an inflator is dropped, replace it with a **NEW** inflator.

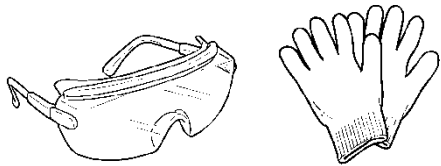

Wear protective eye wear
and work gloves.

4. WEAR PROTECTIVE EQUIPMENT

- a) Always wear appropriate protective equipment when working on the SRS.

VII. SRS SYSTEM HEALTH CHECK

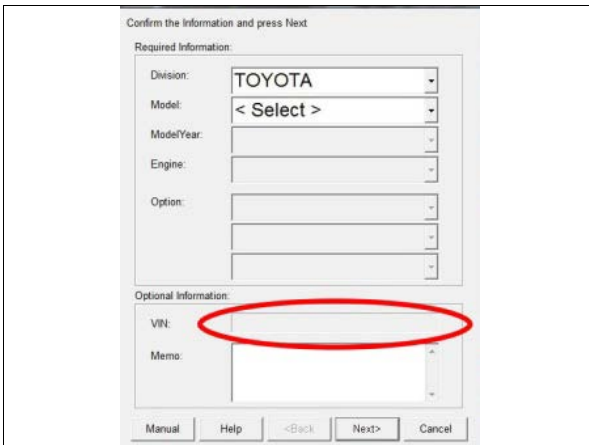

1. PERFORM A HEALTH CHECK

- Confirm the Techstream is connected to the dealership's internet.
- When launching the Techstream software the VIN **MUST** be entered manually.

NOTE: All letters of the VIN *MUST* be entered in ALL CAPS, or the VIN will need to be reentered when running the diagnostic report.

- Perform a health check.



- The VIN **MUST** be entered manually in ALL CAPS when launching the Techstream software, the VIN **MAY NOT** auto-populate due to vehicle age.
- The serial number recording application will be disabled and the repair cannot be completed if a health check and diagnostic report is not performed and recorded by TMS.

VIII. WORK AREA PREPARATION



CRITICAL INFORMATION – READ THOROUGHLY



The anti-static mat set that is an essential SST may be available at your dealership and is optional to use during inflator replacement. If the anti-static kit is not available, before starting work and periodically while working on the vehicle, touch a metallic part of the vehicle to discharge static electricity in the body.

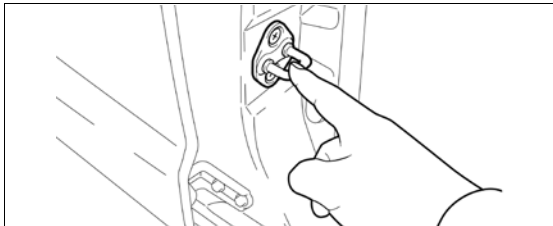

If the anti-static kit is not available, before starting work and periodically while working on the vehicle, touch a metallic part of the vehicle to discharge static electricity in the body.

IX. PASSENGER AIRBAG INFLATOR REPLACEMENT

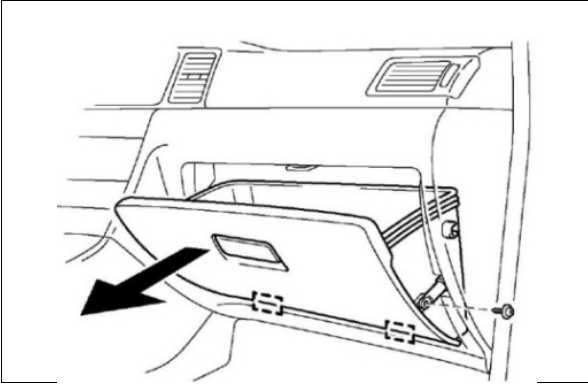

1. REMOVE THE GLOVE BOX

- a) Open the glove box door.
- b) Press in on both sides of the door and swing it down to remove it from the vehicle.

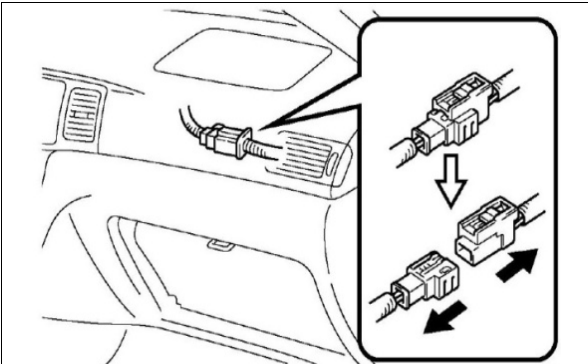

2. REMOVE THE AIRBAG ASSEMBLY

- a) Disconnect the negative battery cable.



- Wait at least 90 seconds after disconnecting the cable from the negative battery terminal to prevent airbag and seat belt pre-tensioner deployment.
- Follow all precautions as outlined on TIS before servicing the SRS system.

- b) Disconnect the airbag connector.

- c) Remove the 2 nuts and release the 6 clips.
- d) Remove the airbag assembly.

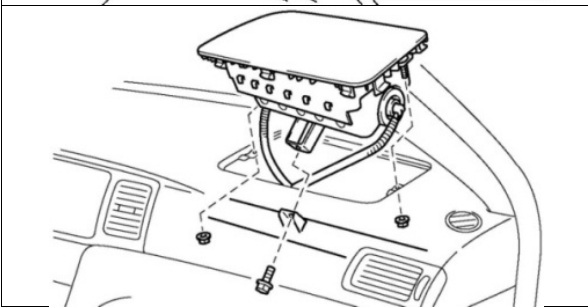

3. CONNECT THE BARCODE SCANNER

- a) Connect the barcode scanner to the USB port on the Techstream.
- b) The scanner will automatically connect and a beep will be heard when the scanner is ready.

NOTE:

- The scanner was provided for SSC D0F.
- The scanner works best in low light conditions.
- Always hold the scanner directly in front of and parallel to the barcode label.

Campaign Phase Interpretation

REMEDY PHASE – ELIGIBLE FOR REPAIR

Campaign Description: Safety Recall J0A - Remedy Notice - Multiple Models - Non-Desiccated Front Passenger Airbag Inflator – “Like for Like” Replacement (Zone A)
Campaign Status: Remedy Available
Completion Status: Not Completed
Memo: Remedy Available

[Show Documents]

STATUS IDENTIFICATION

A: Campaign Status: Remedy Available

B: Memo: Remedy Available

- **This vehicle is eligible to have the remedy performed if the completion status is “Not Completed.”**
- **The original scanning application link can be used.**

Campaign Description: Safety Recall J0A - Remedy Notice - Certain 2003 - 2005 Corolla - Non-Desiccated Front Passenger Airbag Inflator – “Like for Like” Replacement (Zone A)
Campaign Status: Remedy Available
Completion Status: Not Completed
Memo: Remedy Available - Instead of using the scanning application use <https://takata-scan-app.imagespm.info/>

[Show Documents]

STATUS IDENTIFICATION

A: Campaign Status: Remedy Available

B: Memo: Remedy Available – Instead of using the scanning application use <https://takata-scan-app.imagespm.info/>

- **This vehicle is eligible to have the remedy performed if the completion status is “Not Completed.”**
- **The new scanning application website <https://takata-scan-app.imagespm.info/> must be used when performing the remedy.**
- **Login instructions for this new scanning application website are included in the Technical Instructions.**

4. LAUNCH THE SERIAL NUMBER RECORDING APPLICATION



- The ORIGINAL AIRBAG ASSEMBLY, and NEW ASSEMBLY serial numbers MUST be recorded using the barcode scanner.
- The barcode scanner application MUST be completed on every vehicle. These numbers MUST be included on every warranty claim that is submitted for inflator module replacement or the claim may be subject to debit.
- The technician performing the work MUST have an internet connection to perform the inspection and scanning process.

- a) Log into the website via the URL below
<https://takata-scan-app.imagespm.info/>
- b) **User ID:** Dealer Code
First time login password: xxxxx

Login

Complete all required (*) fields below.

* User ID (enter your 5-digit dealer code, or 6-digit for Canadian dealers eg. Cnnnnn format):

* Password:

Login

[Forgot Password?](#)

Technician Information

Please provide information below before searching for VIN.

Technician Name:

SPIN ID (12 digit code):

Search

- c) Enter your name and SPIN ID into the site

Enter VIN

Enter the 17-digit Vehicle Identification Number to begin the search for this campaign.

VIN:

Mileage on Vehicle:

Search

- d) Enter the VIN and vehicle mileage into the site

5. SCAN THE AIRBAG ASSEMBLY SERIAL NUMBER

ATTENTION: This information is **CRITICAL**

- a) Scan the **AIRBAG ASSEMBLY** serial number 2 times.
 - 1) Confirm the cursor is in the first serial number box then scan the serial.
 - 2) Position the cursor in the second serial number box then scan the serial.
- b) Click search.

NOTE:

- If both serial numbers that are entered do not match, confirm and reenter.
- If the serial number barcode will not scan, it can be entered manually.

AIRBAG SERIAL NUMBER IDENTIFICATION

- The airbag serial number is **ALWAYS** the 12 DIGITS located between the asterisks.
- The 3 digits before the asterisk **ARE NOT** part of the serial number, and **SHOULD NOT** be entered or an inaccurate response may be returned.

Airbag Serial Number Label Example



The **AIRBAG ASSEMBLY** serial number and the **INFLATOR** serial number are **DIFFERENT**. The **AIRBAG ASSEMBLY** serial number **MUST** be recorded prior to replacement.

ORIGINAL Airbag Assembly Serial Number

Scan or enter the **original** Airbag Assembly serial number into the website.

VIN:
Model / Campaign:

* Serial Number of **Original** Airbag Assembly:

* Re-confirm the Serial Number of **Original** Airbag Assembly:

Check if the airbag serial number is missing or not visible, or if installing a new airbag assembly

Search

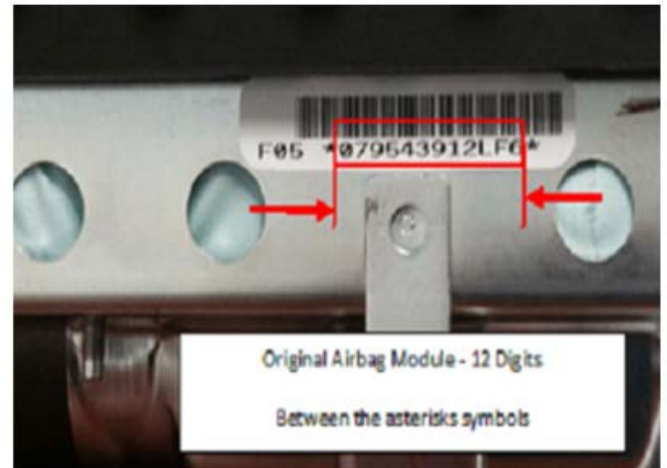

NOTE: You will need to check the box when installing a new assembly



If the airbag serial number and barcode are not legible or are not present, check the box in the application indicating the serial number is not legible and continue with the repair.

You will need to check the box when installing a new assembly

c) Scan the NEW airbag barcode in the Serial Number Recording Application.



Takata Scan App

TMS Test Dealership

[Search Another VIN](#) | [Print Screen](#) | [Log Out](#)

NEW Serial Number

Scan or enter the **new** Airbag Assembly Serial Number into the website.

VIN:

* **Serial Number of New Airbag Assembly:**

* **Re-confirm the Serial Number of New Airbag Assembly:**

[Search](#)

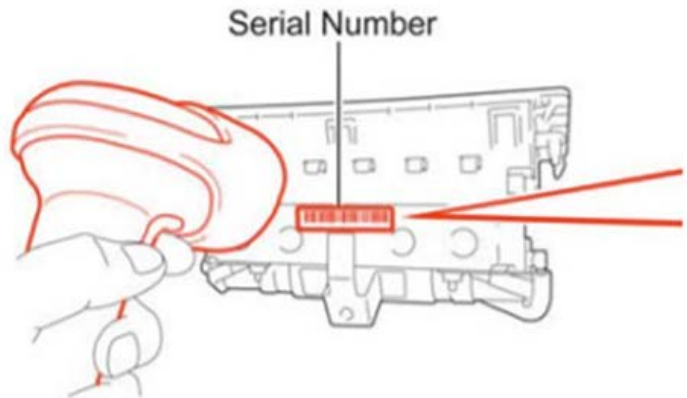

The new **AIRBAG ASSEMBLY** serial number **MUST** be recorded prior to reinstallation to track the airbag assembly to the vehicle.

d) Check the three acknowledgement boxes and click submit

Additional Information and Agreements

Provide additional information below before proceeding to obtain warranty authorization number.

VIN: 2T1KR32E75C508620

Required Acknowledgements:

- I agree to complete the safety recall's remaining technical instructions
- I agree to perform a vehicle Health Check with Techstream upon completion of the safety recall's technical instructions
- I agree to keep the cardboard inserts in this box that it came with (see example in photo below)



[Submit](#)

e) Document the warranty authorization number for the warranty claim



Takata Scan App

TMS Test Dealership

[Search Another VIN](#) | [Print Screen](#) | [Log Out](#)

Takata Scan App Final Results

You can [Print Screen](#) or [Search Another VIN](#).

VIN:	
Scan Date:	08/23/2019 07:00AM (mm/dd/yyyy)
Warranty Authorization Number:	55154K08
<i>This number is required for the warranty claim. Print and save this screen for your records</i>	



The warranty authorization number must be recorded on every warranty claim for each repair

6. NEW SERIAL NUMBER (WEBSITE WILL NOT ACCEPT NEW SERIAL NUMBER)

- a) If directed to the screen below this indicates the serial number entered is not loaded in the system. Confirm if the blue check mark is on the box. If yes, follow the instructions on the screen.

NOTE: Ensure you include a Job Aid and a picture of the Airbag Assembly in your email

NEW Serial Number (confirm if marked label)

Invalid Serial Number. For this model and year the replacement serial must match one of those in the list of good serial numbers

NOTE: This serial number 117428418KDP is not recognized. This part should be returned to Toyota UNLESS there is a mark on the label (shown below).

If there is a mark on the part number label (see image 1 for example) **submit a picture of the airbag assembly showing the cloth section of the airbag and a completed Airbag Inflator Documentation (Job Aid to quality_compliance@toyota.com** (see image 2 for example).

The repair can be performed and completed without a response from the quality_compliance@toyota.com inbox *if the airbag assembly has the cut in the airbag cloth material (shown in image 2).*

If this cut is not present wait on a response from the quality_compliance@toyota.com inbox.

...OR **return to original New Serial Number screen** to re-enter another number.

X. MODULE REPLACEMENT

1. WORKING WITH AIRBAG

- a) Carefully place the airbag on the bench inflator side up.

NOTE: Place clean sheet(s) of paper on the bench to protect the airbag.

- b) Avoid standing directly over the inflator.

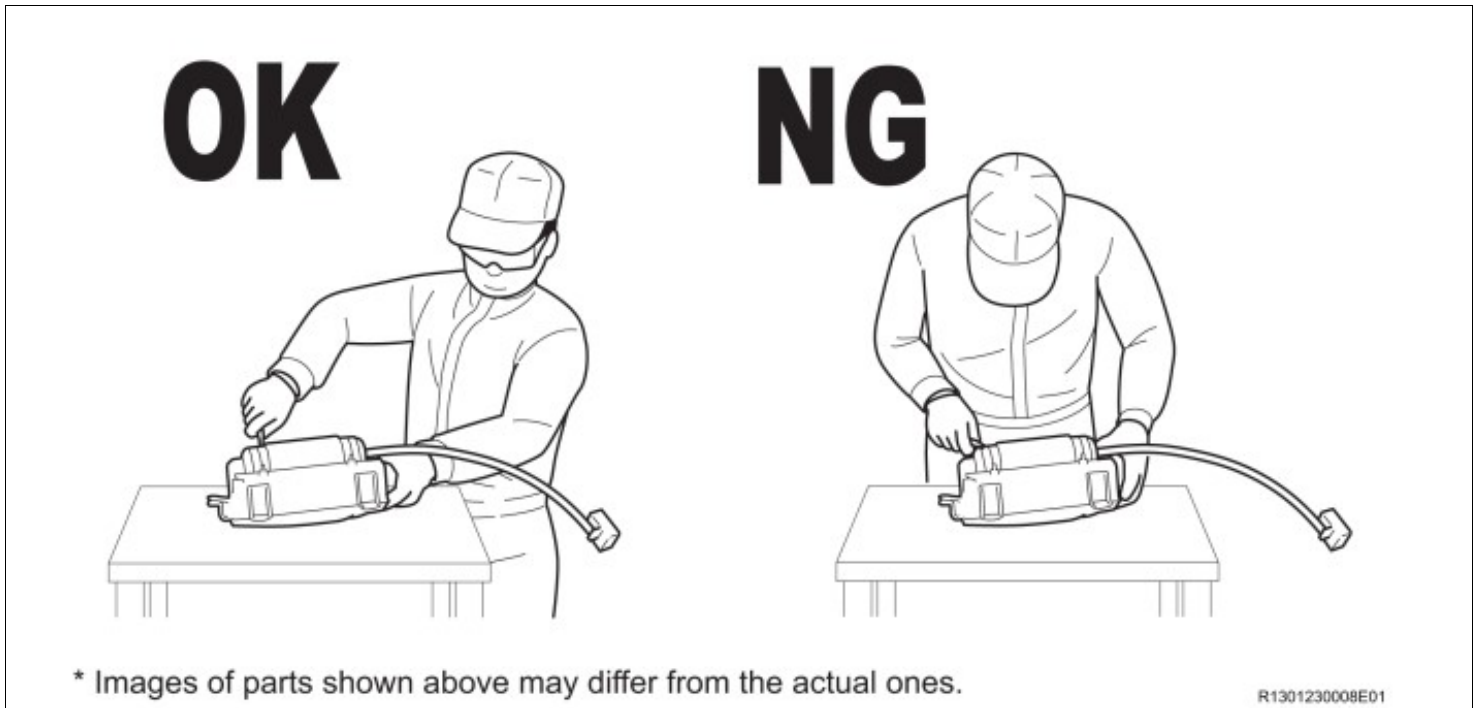

	CRITICAL INFORMATION – READ THOROUGHLY	
	<p>Remember to periodically touch a metallic part of the vehicle to discharge static electricity in the body if the anti-static kit is not being used.</p>	

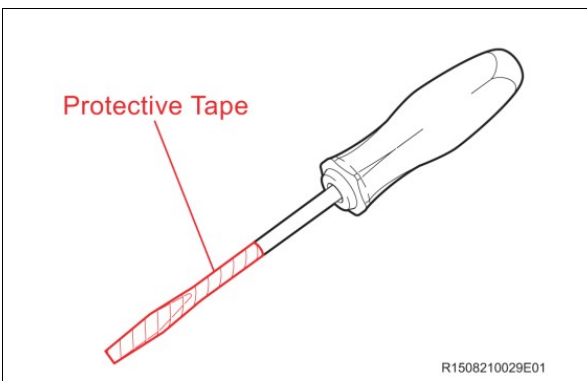

2. TOOL PREPARATION

- a) Wrap a screwdriver with tape.

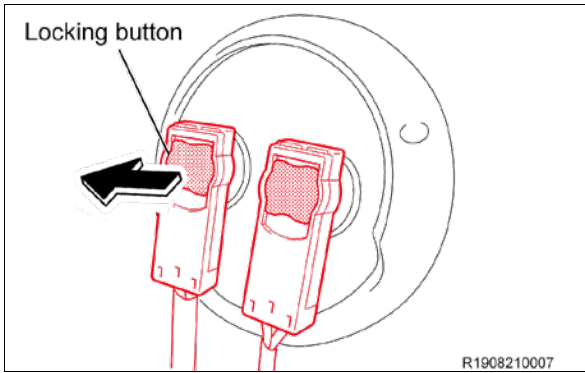

3. REMOVE WIRE HARNESS

- a. Pull up on both lock down tabs
- b. Disconnect the wire harness from the inflator

4. REMOVE THE COVER

- a) Gently insert the screwdriver between the airbag door and module and disengage the claws holding the door to the module. Please refer to the video below.

[VIDEO](#)

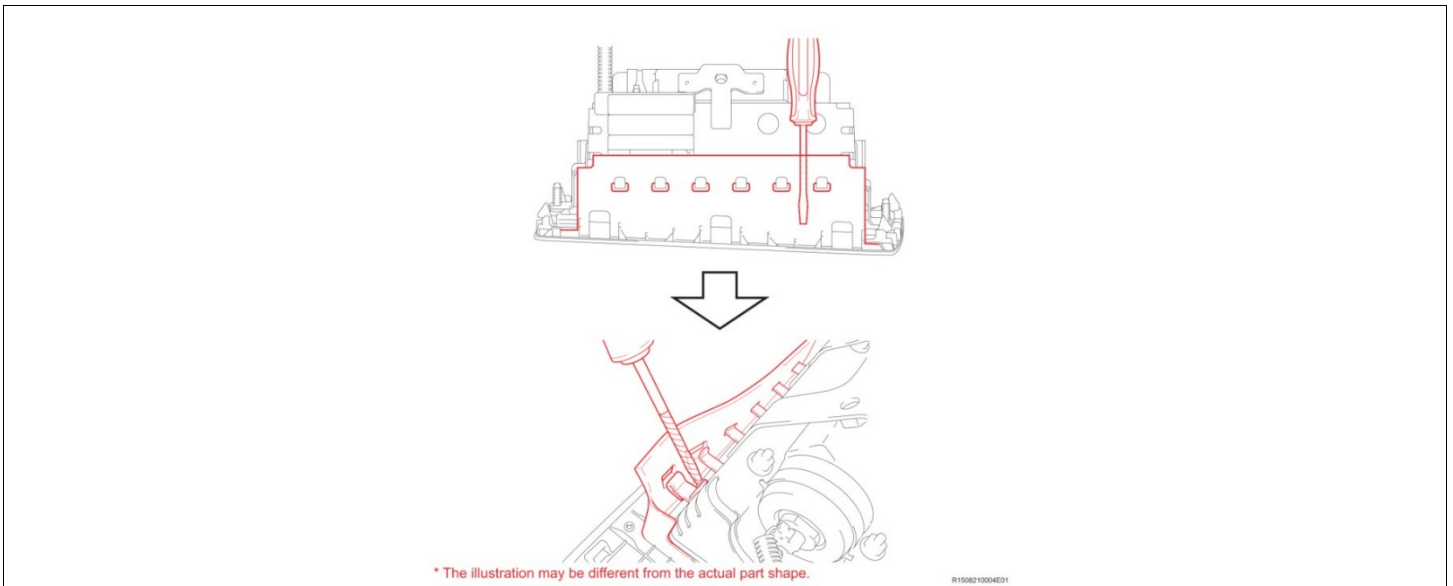

- b) After all the claws have been disengaged separate the module from the door.
- c) Mark the old module so it is not reused.
- d) Inspect the door for damage to the mounting slots.

5. INSTALL THE *NEW* MODULE

Make sure to confirm the following condition. If the module does not fulfill them, order a *NEW* one on which measures for improvement have been taken.



Confirm the protector cloth inside is cut.

Take care not to mistake the mounting direction.

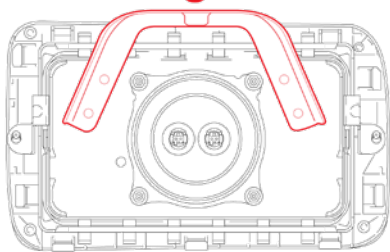

- a) Carefully slide the new module into the airbag door.

NOTE: Mounting direction.

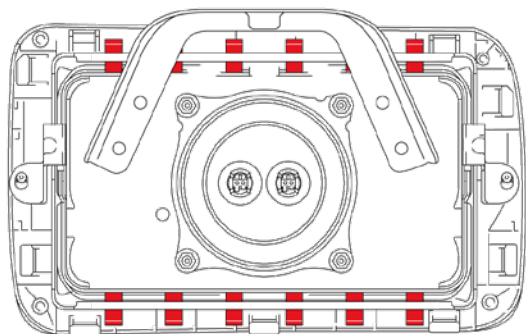

- b) Reengage the tangs of the module into the door using the screwdriver with the shaft wrapped in tape.

Locking button

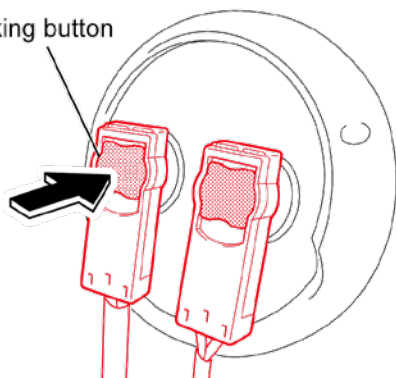

- c) Connect the harness to the new module.
d) Press the lock tab down.

XI. FRONT PASSENGER AIRBAG ASSEMBLY INSTALLATION

1. REINSTALL THE AIRBAG ASSEMBLY

Note: During reinstallation of the airbag assembly, ensure the 12mm bolt and two 10mm nuts securing the airbag assembly to the instrument panel are installed and torqued to the required specification identified on TIS.

- a) Refer to TIS for instructions on airbag installation:

Matrix [2005MY](#) [2006MY](#) [2007MY](#) [2008MY](#)

2. RECONNECT THE NEGATIVE BATTERY CABLE

3. PERFORM A HEALTH CHECK AND DIAGNOSTIC REPORT

4. RETURN THE REMOVED AIRBAG ASSEMBLY TO THE PARTS DEPARTMENT

