

TECHNICAL INSTRUCTIONS

FOR

SAFETY RECALL KLF

POTENTIAL LOSS OF POWER BRAKE ASSIST

CERTAIN 2019 UX 250h

The repair quality of covered vehicles is extremely important to Lexus. All dealership technicians performing this recall are required to successfully complete the most current version of the E-Learning course “Safety Recall and Service Campaign Essentials”. To ensure that all vehicles have the repair performed correctly; technicians performing this recall repair are required to currently hold at least one of the following certification levels:

- Senior
- Master

It is the dealership’s responsibility to select technicians with the above certification level or greater to perform this recall repair. Carefully review your resources, the technician skill level, and ability before assigning technicians to this repair. It is important to consider technician days off and vacation schedules to ensure there are properly trained technicians available to perform this repair at all times.

I. OPERATION FLOW CHART

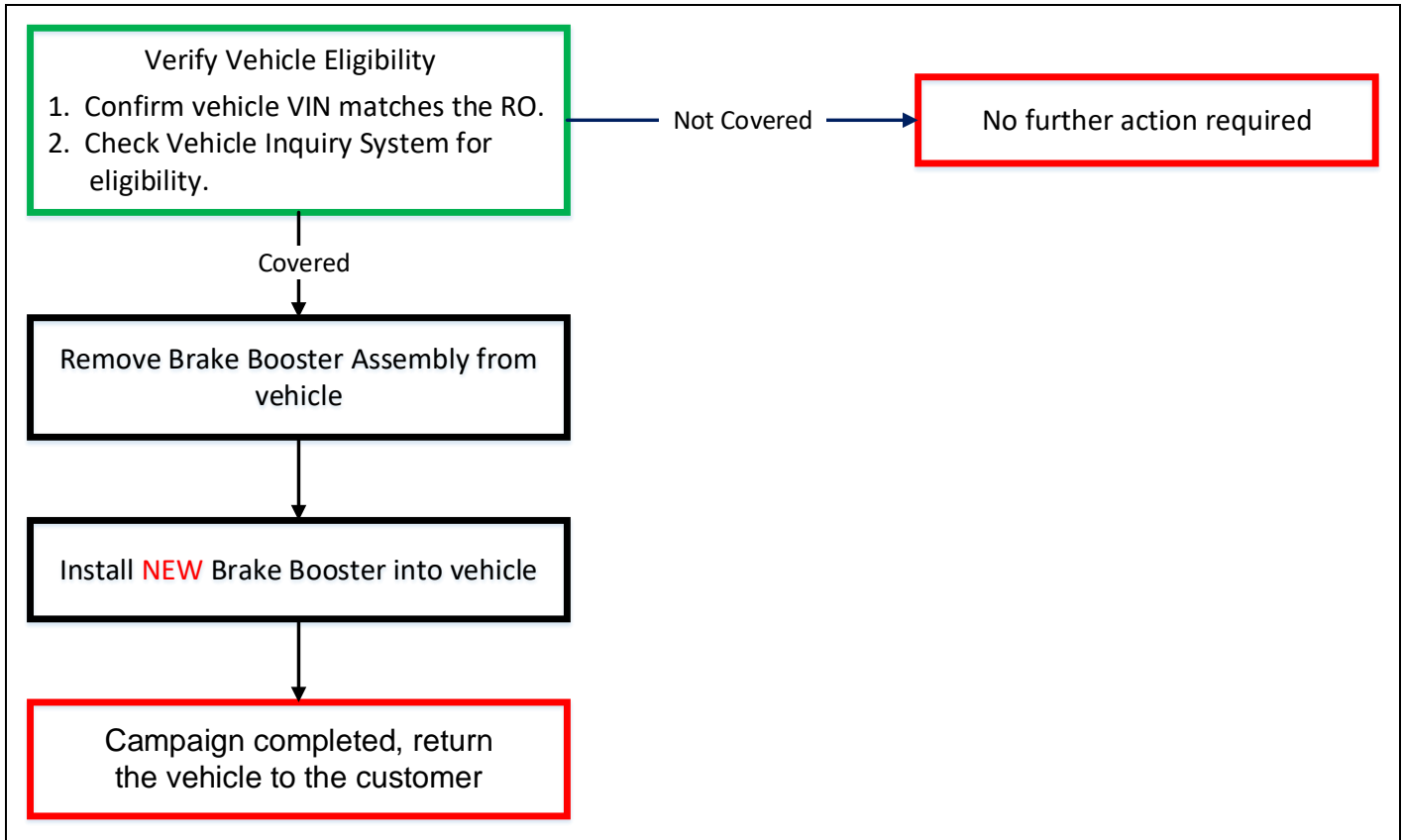

II. IDENTIFICATION OF AFFECTED VEHICLES

1. CHECK VEHICLE FOR CAMPAIGN ELIGIBILITY

- Compare the vehicles VIN to the VIN listed on the Repair Order to ensure they match.
- Check the TIS Vehicle Inquiry System to confirm the VIN is involved in this Campaign, and that it has not already been completed.

Note: TMNA warranty will not reimburse dealers for repairs completed on vehicles that are not affected or were previously completed, even by another dealer.

III. PREPARATION

A. PARTS

Model	Part Number	Part Description	Quantity
UX 250h	04009-56712	Brake Pump Assy w/ Accumulator	1

B. TOOLS & EQUIPMENT

- Techstream
- Standard Hand Tools
- Torque Wrench

C. MATERIALS

- Brake Fluid: SAE J1703 or FMVSS No. 116 DOT 3; SAE J1704 or FMVSS No. 116 DOT 4

IV. BACKGROUND

In the subject vehicles, there is a possibility the brake booster pump may have been manufactured improperly, and in some cases, it may stop operating. If the brake booster pump stops operating, multiple warning lights and messages will illuminate, and/or audible chimes will sound. In this condition, braking assist could be lost completely after several brake pedal applications, resulting in increased stopping distance. In addition, the Vehicle Stability Control will become deactivated, and other vehicle features could be affected. Deactivating the Vehicle Stability Control system may cause the subject vehicles to not meet the certain requirements of FMVSS No. 126. A deactivated Vehicle Stability Control or a sudden and complete loss of braking assist while driving could increase the risk of a crash.

V. COMPONENTS

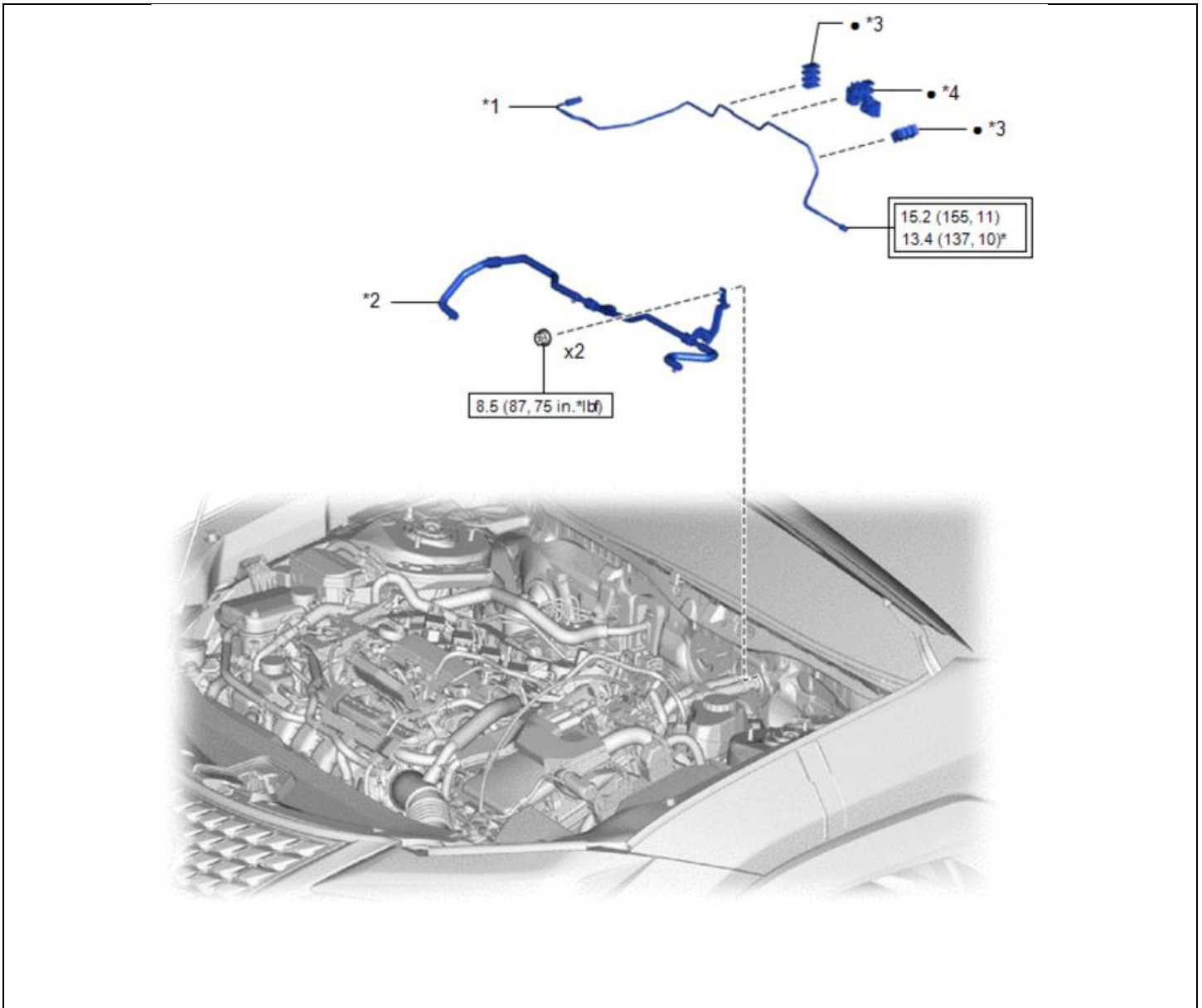

*1	ACCUMULATOR TO BRAKE MASTER CYLINDER TUBE	*2	NO. 1 BRAKE ACTUATOR TUBE
*3	NO. 1 BRAKE TUBE CLAMP	*4	NO. 2 BRAKE TUBE CLAMP

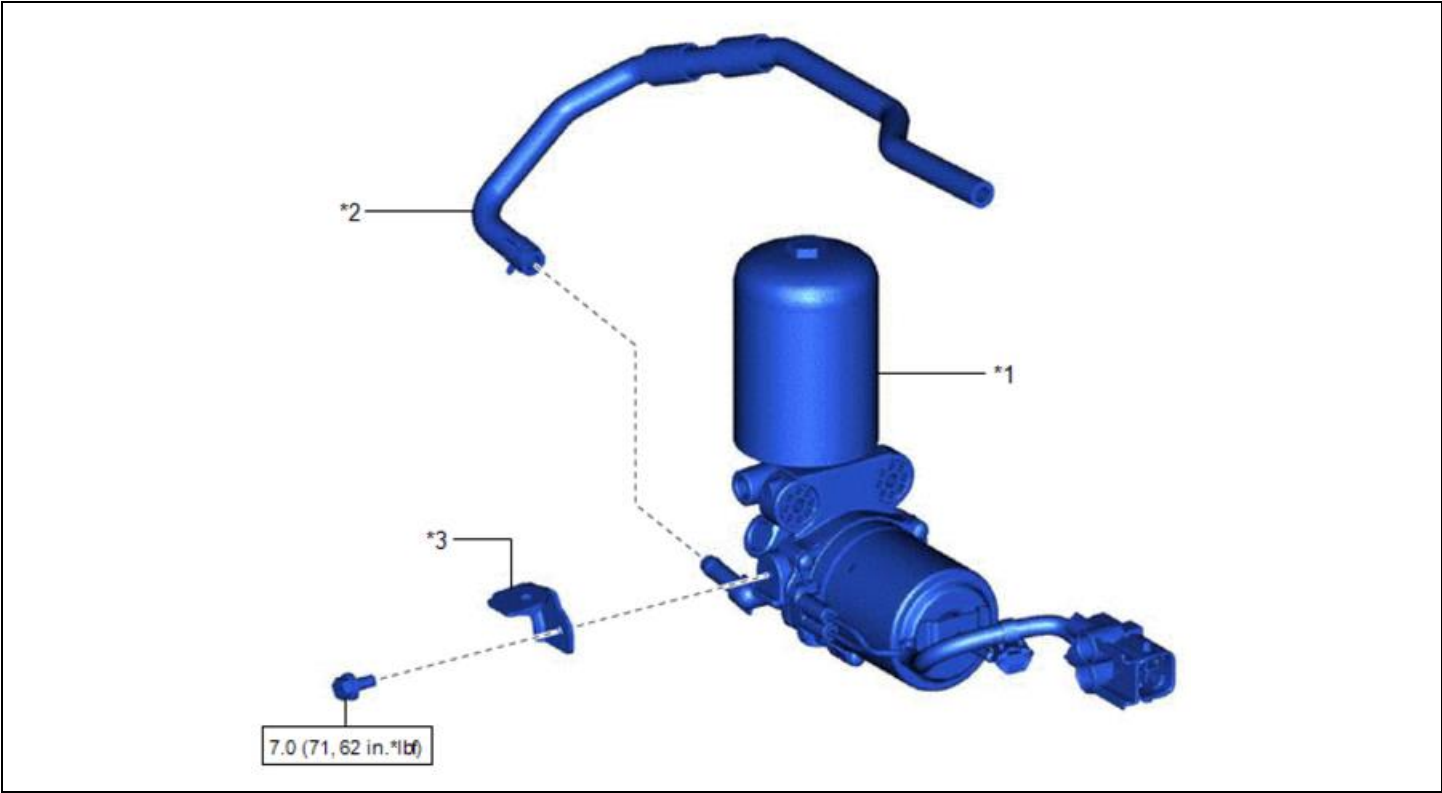

*1	BRAKE BOOSTER PUMP ASSEMBLY	*2	NO. 1 BRAKE ACTUATOR HOSE
*3	NO. 1 BRAKE TUBE CLAMP BRACKET	-	-
<input type="checkbox"/>	N*m (kgf*cm, ft.*lbf): Specified torque	-	-

VI. DISASSEMBLY



1. CHECK FOR DTC'S

- a. Using a Techstream, check for Diagnostic Trouble Codes.

Note: *This Safety Recall covers only the replacement of the brake booster pump, as detailed in these instructions. It does not cover the diagnosis or replacement of any other parts on the vehicle, including the hybrid system.*

2. REMOVE FRONT WIPER MOTOR ASSEMBLY AND TOP VENTILATOR

- a. Follow the Repair Manual procedure to remove the front wiper assembly and top ventilator.

[WIPER / WASHER: FRONT WIPER MOTOR: REMOVAL; 2019 MY UX200 UX250H RM100000001DXLD](#)

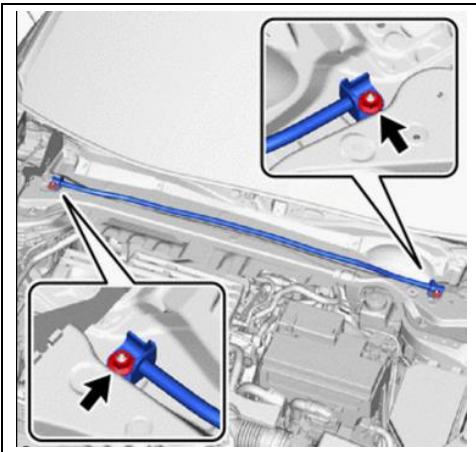

3. REMOVE FRONT PERFORMANCE ROD

- a. Remove the 2 nuts.

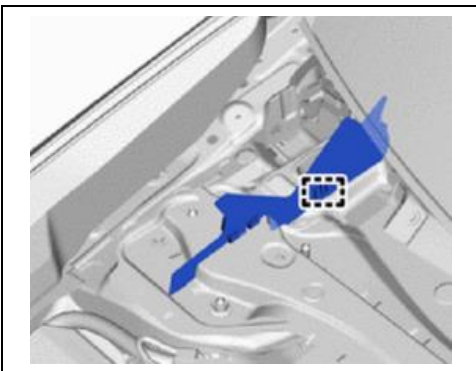

4. REMOVE WATER GUIDE PLATE

- a. Disengage the claw.

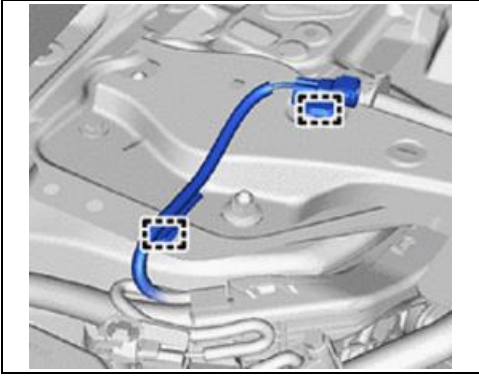

5. REMOVE OUTER COWL TOP PANEL

- a. Disconnect the connector (if equipped with Windshield Deicer.)
- b. Disengage the 2 clamps on the RH side.

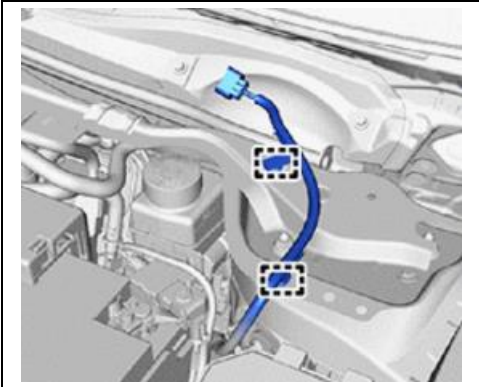

- c. Disengage the 2 clamps on the LH side.

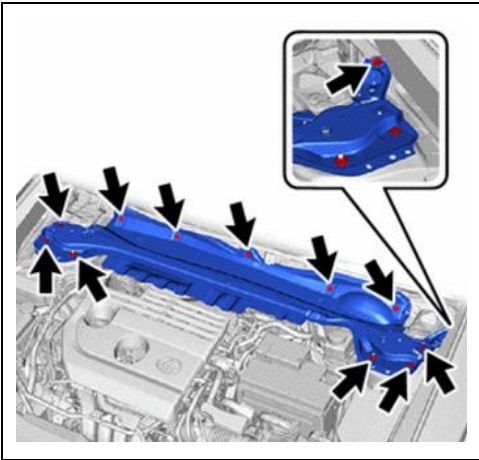

- d. Remove the 10 bolts, 2 nuts of the outer cowl panel.

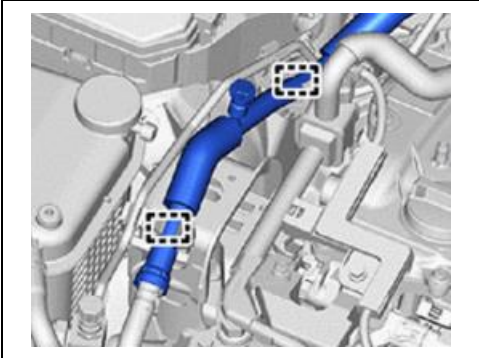

6. SEPERATE SUCTION TUBE

- a. Disengage the 2 clamps between the refrigerant suction tube and the body.

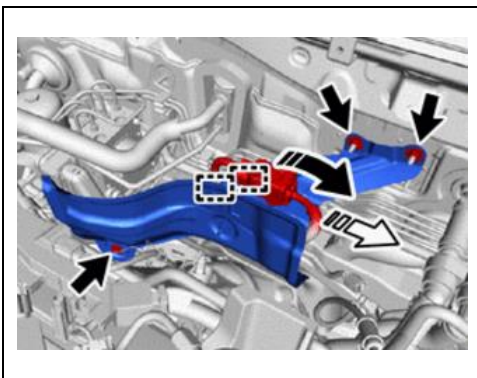

7. REMOVE DASH PANEL HEAT INSULATOR

- a. Disengage the brake booster connector.
- b. Disengage the 2 clamps to separate the wire harness.
- c. Remove the 3 nuts from the dash panel heat insulator.

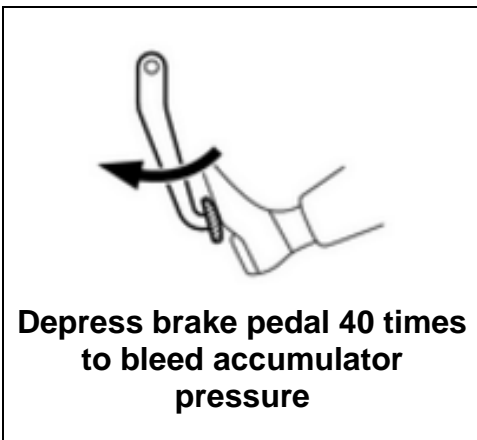

8. PERFORM ACCUMULATOR PRESSURE ZERO DOWN

- a. Confirm the Power switch is OFF.
- b. Verify the brake booster connector is disconnected, as performed in Step# 7.
- c. Remove brake fluid, if necessary, from the reservoir so that the level is below the Full mark.
- d. Depress the brake pedal 40 times to bleed the accumulator pressure back to the reservoir.
- e. Confirm the brake pedal is firm.

Note: During this procedure, it is normal for the buzzer to sound due to the low accumulator pressure.

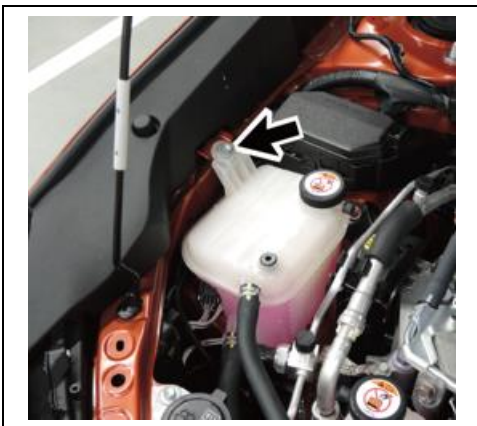

9. REMOVE COOLANT RESERVOIR

- a. Remove the bolt.
- b. Reposition the reservoir to allow access to this area.

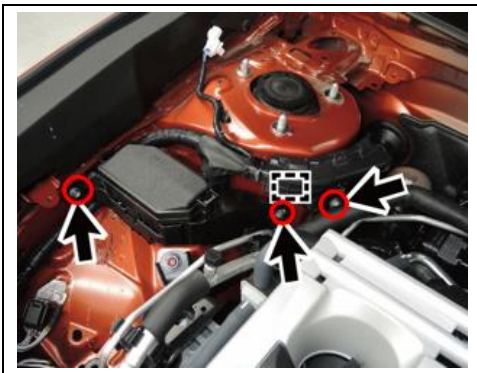

10. SEPARATE WIRE HARNESS

- a. Remove the 2 bolts and nut.
- b. Disengage the clamp.

c. Disengage the connector.

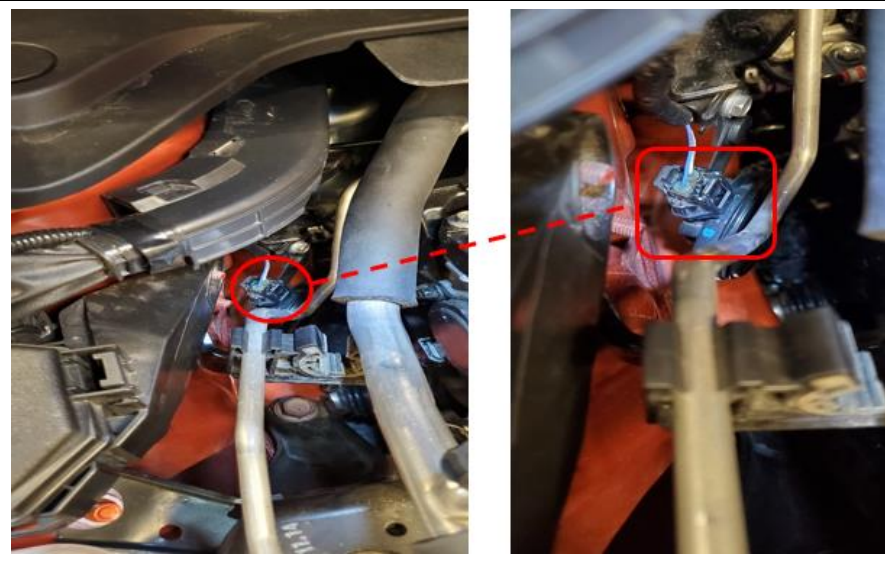

d. Reposition the engine room harness on top of the strut tower as shown.

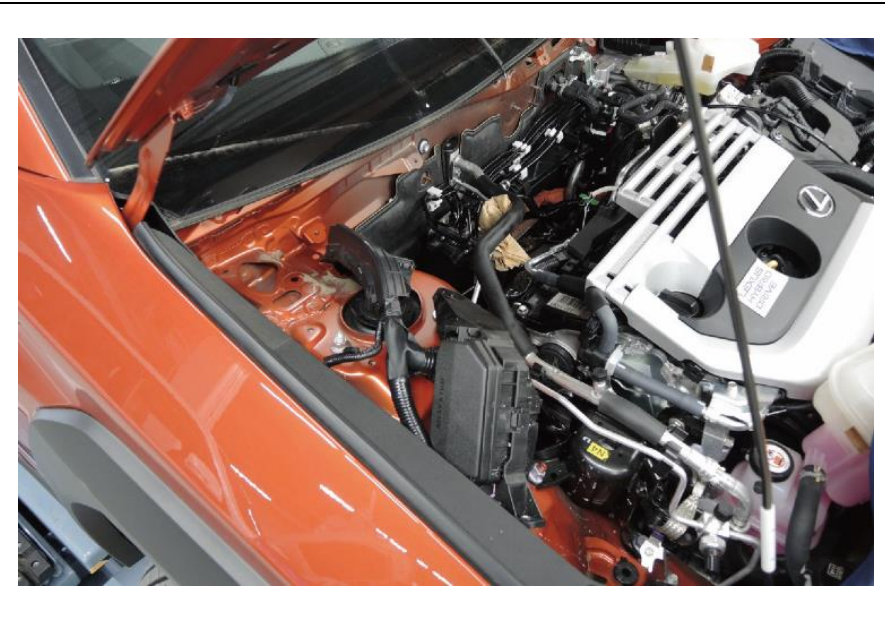

VII. BOOSTER PUMP REMOVAL



1. REMOVE BRAKE FLUID TUBE AND HOSE

- a. Place a line clamp on the soft rubber hose on the exit of the brake fluid reservoir.



It is not necessary to disconnect the refrigerant lines to remove the booster pump. Follow these instructions for details.

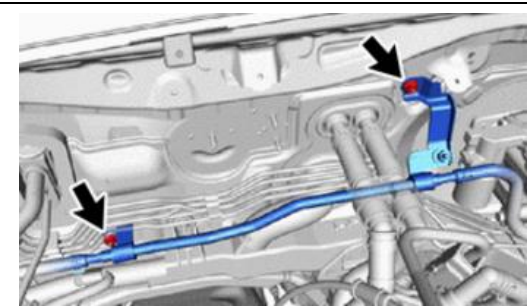

- b. Remove the 2 nuts from the No. 1 brake actuator tube mounting brackets.

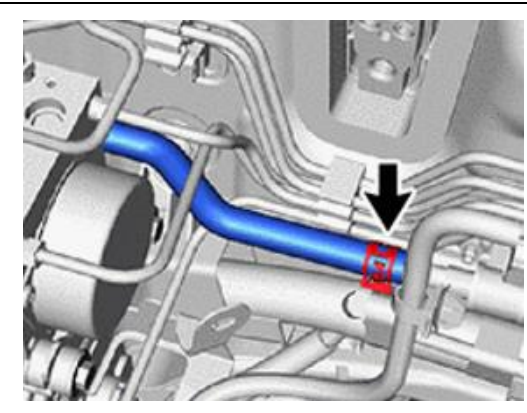

- c. Place towels underneath the brake actuator hose to absorb residual brake fluid.
- d. Slide the clip and disconnect the No.1 brake actuator hose from the No. 1 brake actuator tube.

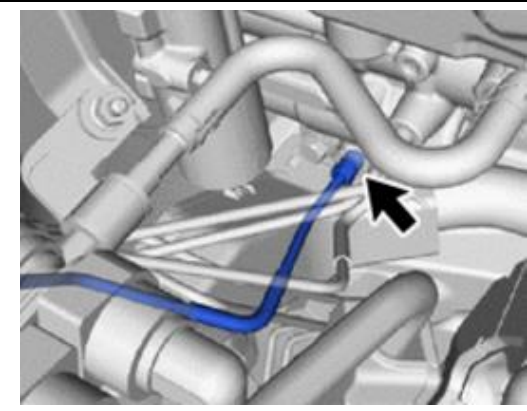

2. REMOVE ACCUMULATOR TUBE

- a. Using a union wrench, disconnect the accumulator to brake master cylinder fitting from the master cylinder.

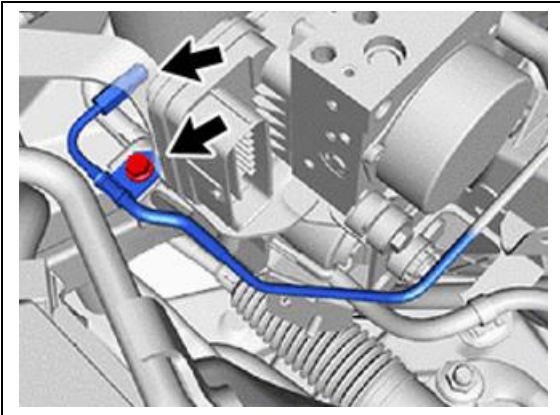

b. Using a union wrench, disconnect the accumulator to brake master cylinder fitting from the brake booster pump assembly.

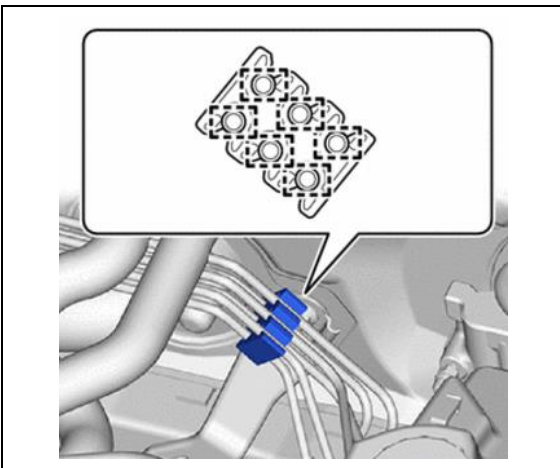

c. Disengage the 6 clamps to separate the No. 1 brake tube.

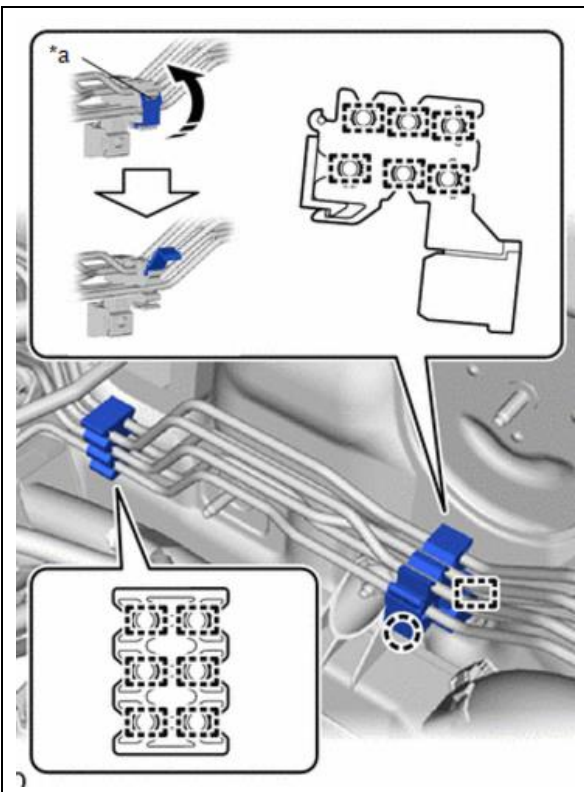

d. Disengage the claw to open the clamp cover.
 e. Disengage the 6 clamps to separate the No. 1 brake tube and accumulator tube.
 f. Remove the accumulator to brake master cylinder tube.

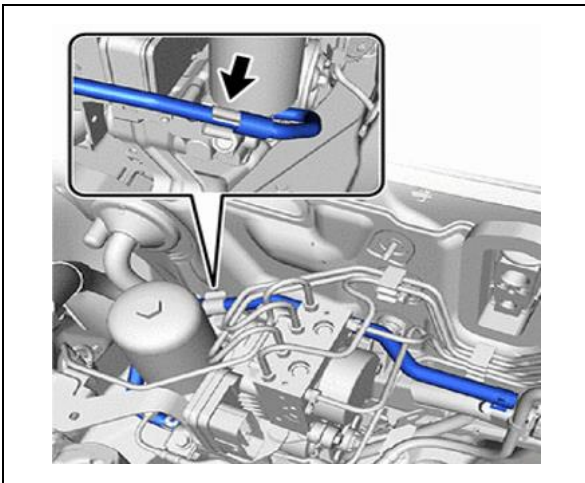

- g. Separate the No. 1 brake actuator hose from the clamp.

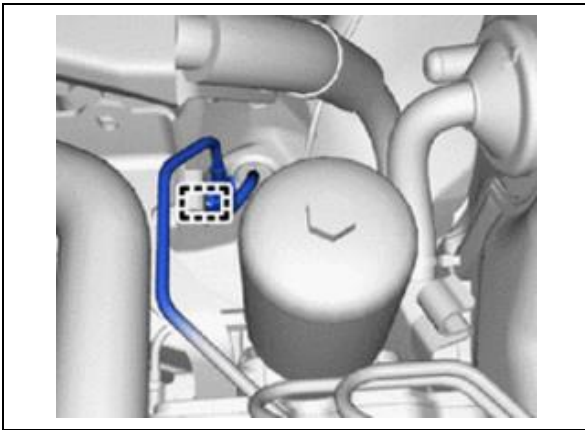

- 3. **REMOVE BRAKE BOOSTER PUMP ASSEMBLY**
 - a. Disengage the clamp to separate the No. 3 front brake tube from the brake actuator bracket.

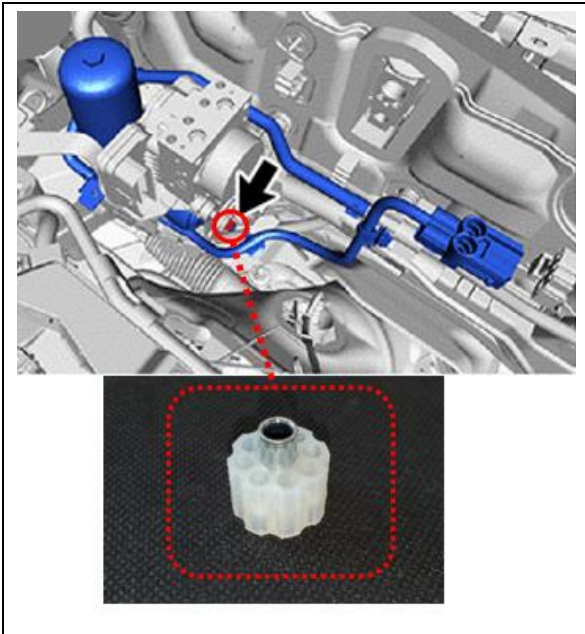

- b. Remove the nut from the brake actuator bracket.

Note: Be cautious of the rubber bushing when removing the brake booster pump.



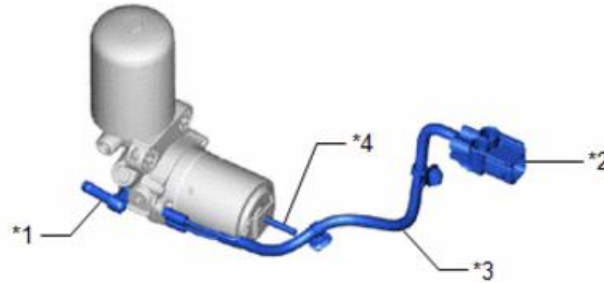
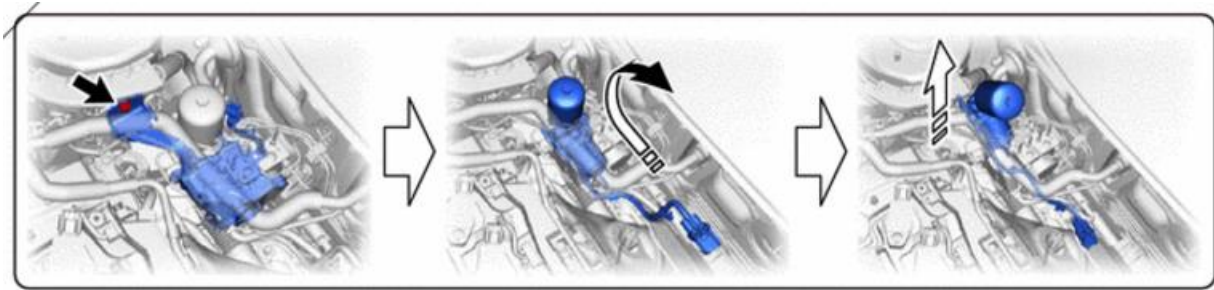

To prevent damage to the booster pump and surrounding components, be sure to follow the steps as detailed below.

c. Remove the brake booster pump assembly as shown in the illustration below.



0

*1	Union	*2	Connector
*3	Wire Harness	*4	Stud
	Remove in this Direction (1)		Remove in this Direction (2)

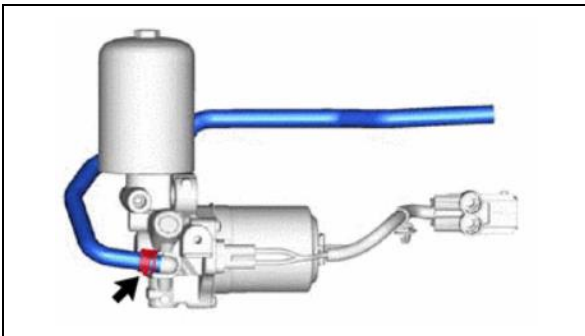

4. REMOVE BRAKE ACTUATOR HOSE

- a. Slide the clip and remove the No. 1 brake actuator hose from the brake booster pump.

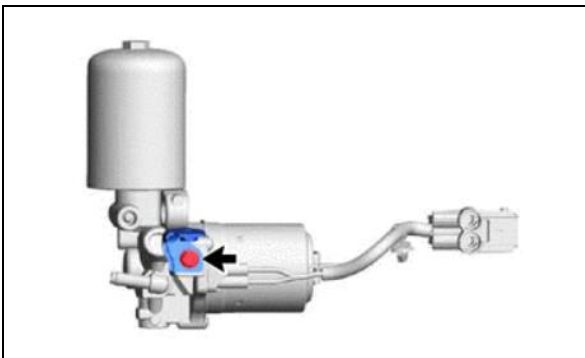

5. REMOVE TUBE CLAMP BRACKET

- a. Remove the bolt and No.1 brake tube clamp bracket.

VIII. BOOSTER PUMP INSTALLATION

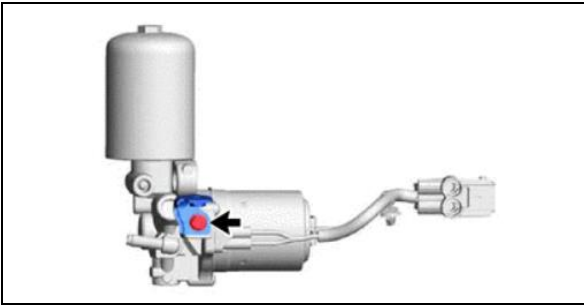

1. INSTALL TUBE CLAMP BRACKET

- a. Install the brake tube clamp bracket and bolt.

Torque: 7.0 N·m {71 kgf·cm, 62 in.lbs}

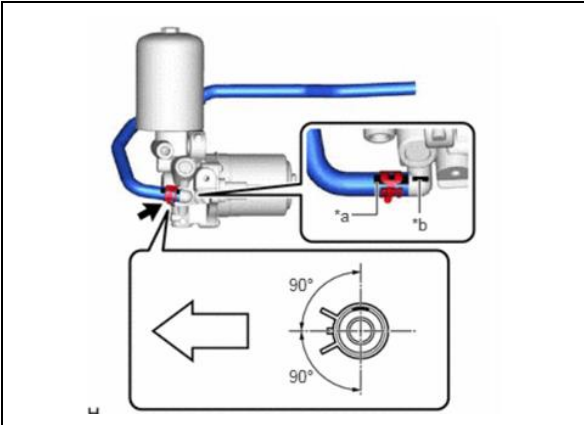

2. INSTALL BRAKE ACTUATOR HOSE

- a. Install the brake actuator hose to the **NEW** brake booster.

Note: Make sure to align the mark on the hose with the mark on the rib of the brake booster pump.

*a	Alignment Mark
*b	Rib of Brake Booster Pump Assembly Port

3. INSTALL BRAKE BOOSTER PUMP

- a. Install the brake booster pump assembly as shown in the illustration

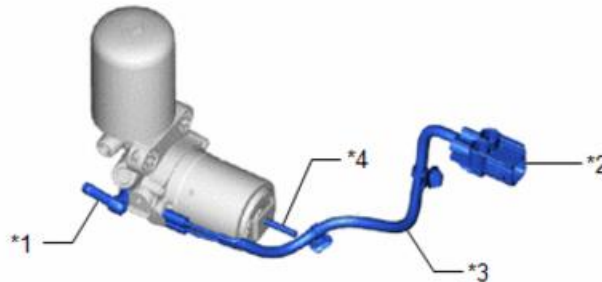
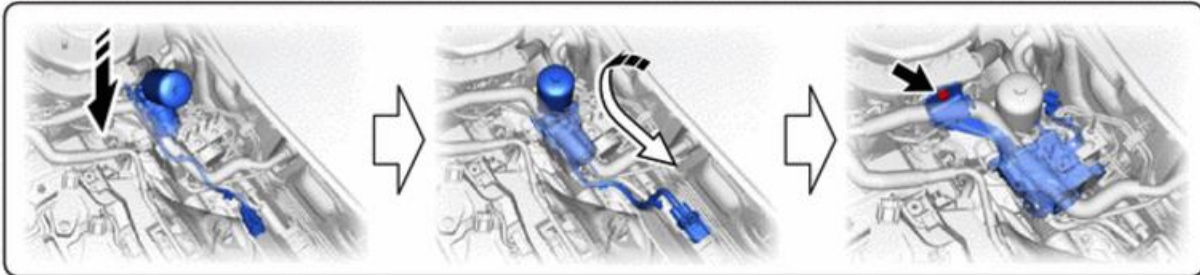

o

*1	Union	*2	Connector
*3	Wire Harness	*4	Stud
	Install in this Direction (1)		Install in this Direction (2)

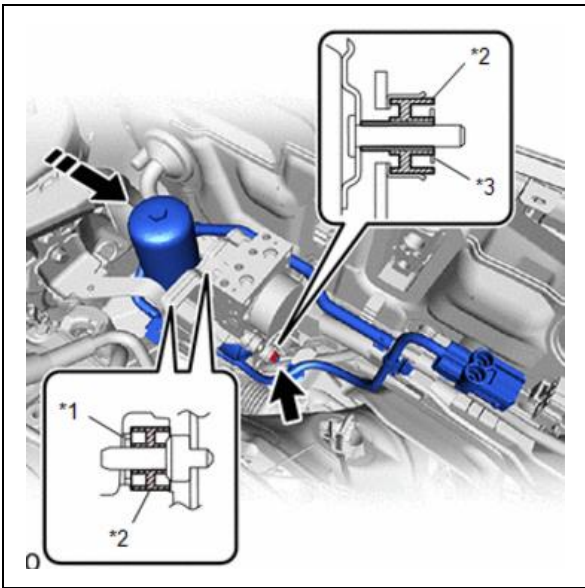

b. Install the nut on the end of the pump.

Torque: 6.5 N·m {66 kgf·cm, 58 in.lbs}

Note: Be sure to confirm the bushings and case collars are properly installed.

*1	Brake Booster Pump Collar
*2	Brake Booster Pump Bushing
*3	Brake Actuator Case Collar

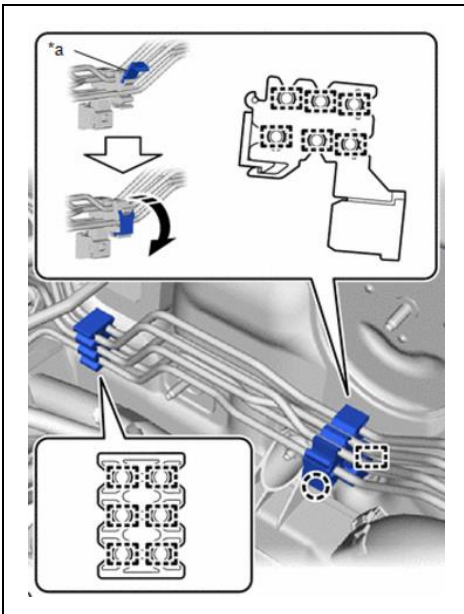

4. INSTALL ACCUMULATOR TO MASTER CYLINDER TUBE

- a. Temporarily install the accumulator to master cylinder tube into the tube clamp.
- b. Engage all 6 tubes into the clamps.
- c. Engage the cover to secure the tube clamps to the vehicle body.

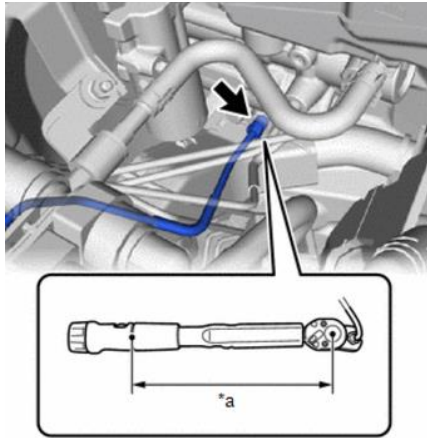

- d. Connect the tube to the master cylinder.
- e. Using a union nut wrench, torque the tube to the master cylinder.

Torque: 15.2 N·m {155 kgf·cm, 132 in.lbs}

Note: Calculate the corrected Torque wrench setting using the following chart when using a union nut wrench on a torque wrench.

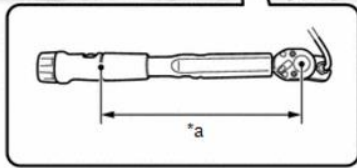

- f. Temporally install the tube into the brake booster pump.
- g. Install the clamp to the master cylinder with the bolt.

Torque: 7.0 N·m {71 kgf·cm, 62 in.lbs}

- h. Using a union nut wrench, tighten the brake master cylinder tube at the booster pump.

Torque: 15.2 N·m {155 kgf·cm, 132 in.lbs}

Note: Calculate the corrected Torque wrench setting using the following chart when using a union nut wrench on a torque wrench.

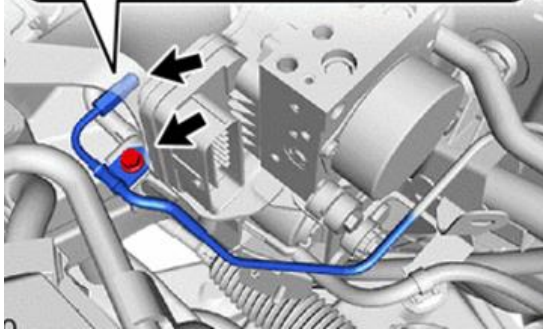
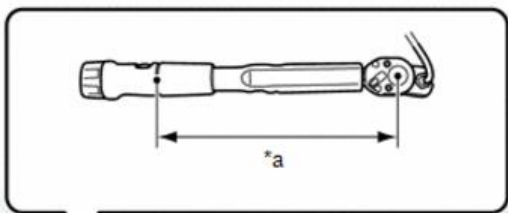

Torque Wrench Setting (in.lbs)

Torque Spec: 132 in.lbs

Length of Torque Wrench (L): inches

	10.0	10.5	11.0	11.5	12.0	12.5	13.0	13.5	14.0	14.5
Length of	120.0	120.5	121.0	121.4	121.8	122.2	122.6	122.9	123.2	123.5
Crowfoot	117.3	118.0	118.5	119.1	119.5	120.0	120.4	120.8	121.2	121.5
(C): inches	114.8	115.5	116.2	116.8	117.3	117.9	118.3	118.8	119.2	119.6
	112.3	113.1	113.9	114.6	115.2	115.8	116.3	116.9	117.3	117.8
	110.0	110.9	111.7	112.4	113.1	113.8	114.4	115.0	115.5	116.0
	107.8	108.7	109.6	110.4	111.2	111.9	112.5	113.1	113.7	114.3

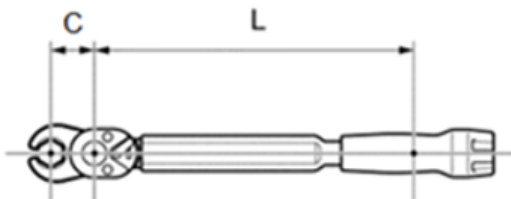

$$\text{Torque Setting} = \frac{\text{Torque Spec} \times L}{C + L}$$

L	Length of torque wrench (in.)
C	Length of crowfoot wrench (in.)

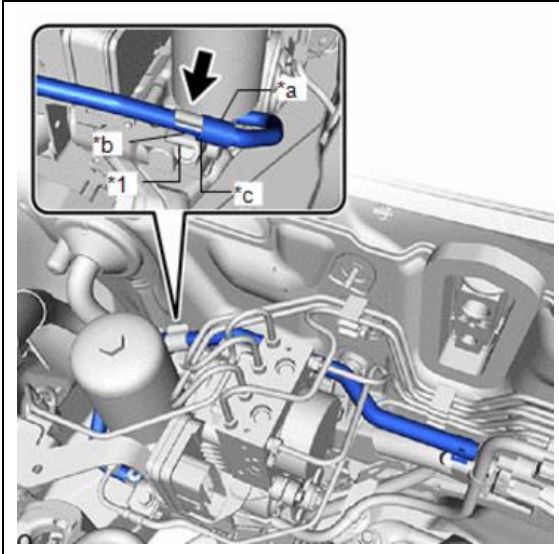

5. INSTALL NO.1 BRAKE ACTUATOR HOSE

- a. Install the No. 1 brake actuator hose to the brake actuator hose clamp.

*1	Brake Actuator Hose Clamp
*a	Protector
*b	Identification Mark
*c	Contacts

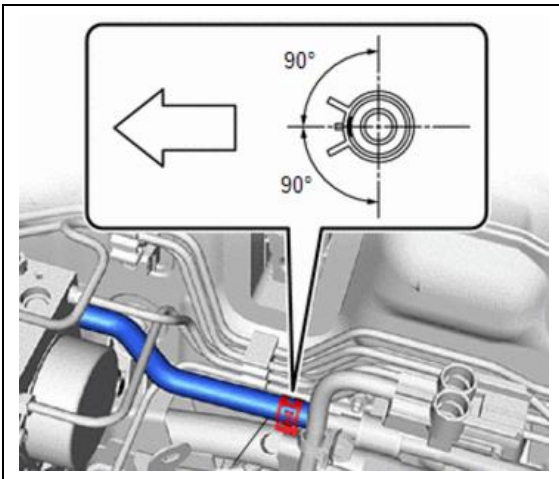

6. CONNECT HOSE TO BRAKE ACTUATOR

- a. Connect the hose to the brake actuator tube, and slide the clamp to secure it.

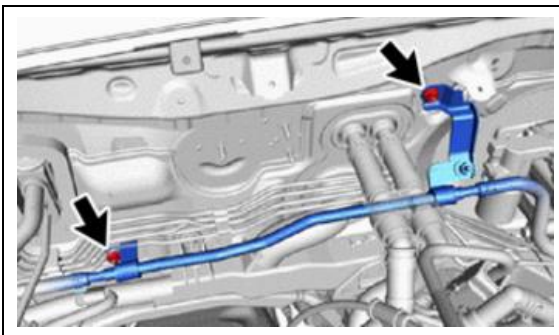

- b. Install the 2 nuts onto the No. 1 brake actuator tube mounting brackets.

Torque: 5.0 N·m {51 kgf·cm, 44 in.lbs}

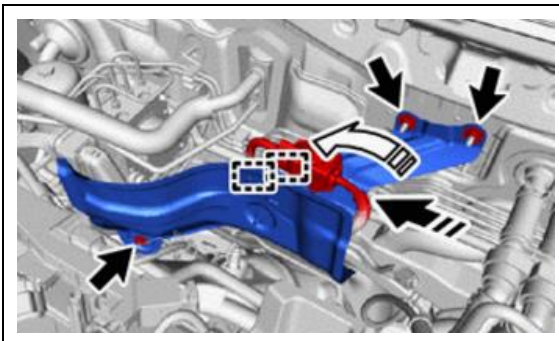

7. INSTALL DASH PANEL HEAT INSULATOR

- a. Install the dash panel heat insulator with the 3 nuts.

Torque: 5.0 N·m {51 kgf·cm, 44 in.lbs}

- b. Engage the 2 clamps to secure the wire harness.
- c. Connect the electrical connector.



- d. Engage the electrical connector.
- e. Reposition the engine room harness to its original position.

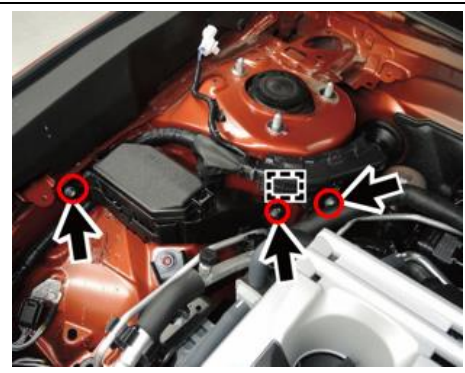

8. ATTACH WIRE HARNESS

- a. Install the 2 bolts and nut.

Torque: 5.0 N·m {51 kgf·cm, 44 in.lbs}

- b. Engage the clamp.

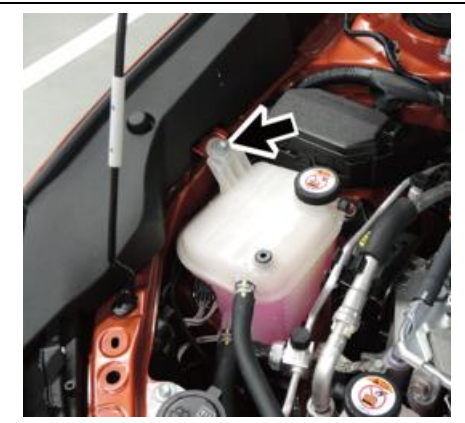

9. INSTALL COOLANT RESERVOIR

- a. Install the bolt.

Torque: 5.0 N·m {51 kgf·cm, 44 in.lbs}

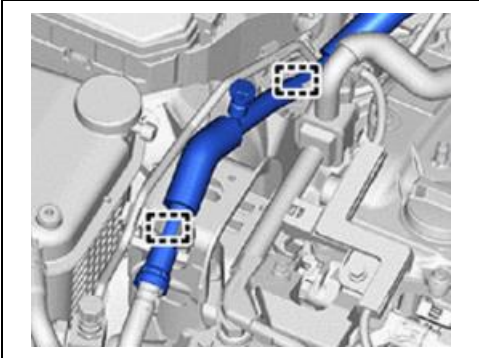

10. ATTACH SUCTION TUBE

- a. Attach the 2 clamps between the refrigerant suction tube and the body.

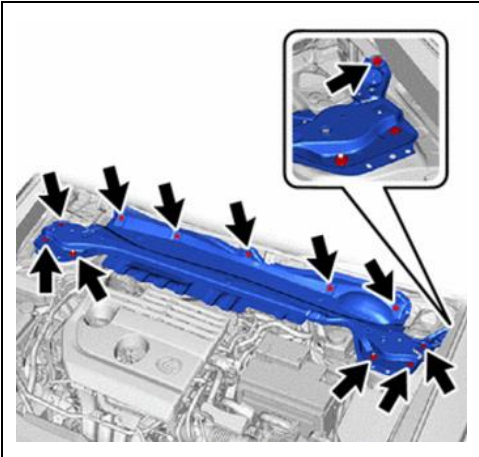

11. INSTALL OUTER COWL TOP PANEL

- a. Install the 10 bolts, 2 nuts of the outer cowl top panel.

Bolt Torque: 12 N·m {122 kgf·cm, 108 in.lbs}

Nut Torque: 50 N·m {510 kgf·cm, 37 ft.lbs}

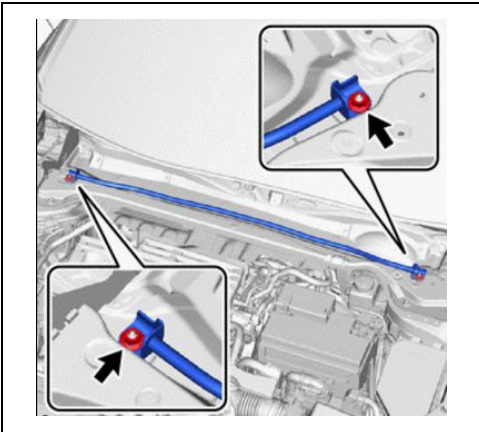

12. INSTALL FRONT PERFORMANCE ROD

- a. Install the 2 nuts.

Torque: 50 N·m {510 kgf·cm, 37 ft.lbs}

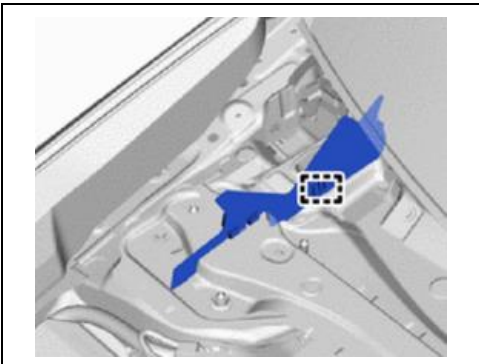

13. INSTALL WATER GUIDE PLATE

- a. Engage the claw to install the water guide plate to the outer cowl top panel.

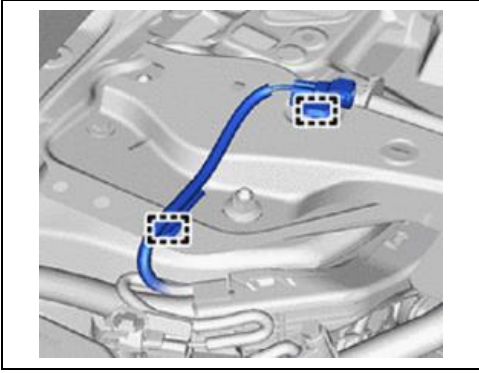

14. INSTALL OUTER COWL TOP PANEL HARNESSSES

- a. Engage the 2 clamps on the RH side.
- b. Connect the electrical connector (if equipped with Windshield Deicer.)

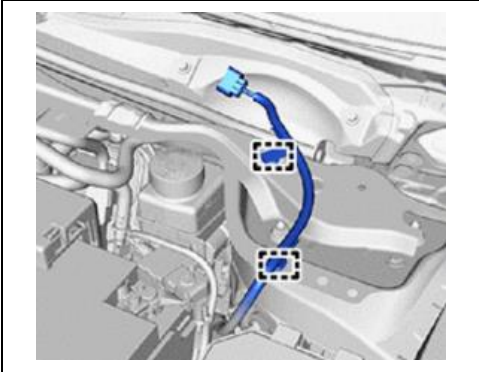

- c. Engage the 2 clamps on the LH side.

15. INSTALL FRONT WIPER MOTOR ASSEMBLY AND TOP VENTILATOR

- a. Follow the Repair Manual procedure to install the front wiper assembly and top ventilator.

[WIPER / WASHER: FRONT WIPER MOTOR: INSTALLATION; 2019 MY UX200 UX250H](#) RM100000001DXLE

16. BLEED BRAKE SYSTEM

- a. Remove the line clamp from the brake fluid reservoir hose.
- b. Follow the Repair Manual procedure to bleed air from the brake system.

[BRAKE SYSTEM \(OTHER\): BRAKE FLUID\(for HV Model\): BLEEDING; 2019 MY UX250H](#) RM100000001FHB6



17. CLEAR DTC'S

- a. Using a Techstream, perform a Health Check.
- b. Clear any DTC's that may have been set during this process.
- c. Perform a second Health Check to confirm that no faults are present.

Note: *This Safety Recall covers only the replacement of the brake booster pump, as detailed in these instructions. It does not cover the diagnosis or replacement of any other parts on the vehicle, including the hybrid system.*

◀ VERIFY REPAIR QUALITY ▶

- Confirm the braking performance is normal.
- Confirm the brake fluid level is correct.
- Confirm there are no DTC's present.

If you have any questions regarding this update, please contact your regional representative.

IX. APPENDIX

A. PARTS DISPOSAL

As required by Federal Regulations, please make sure all recalled parts (original parts) removed from the vehicle are disposed of in a manner in which they will not be reused, ***unless requested for parts recovery return.***

B. CAMPAIGN DESIGNATION DECORDER

