

# Recall Bulletin 190709REV



**RECALL BULLETIN:**  
190709REV

**YEAR(S) AFFECTED:**  
2016-2019

**PRODUCT(S) AFFECTED:**  
2016-2019 American Eagle manufactured 12/19/2014 through 05/31/2019  
2016 American Heritage manufactured 08/18/2015 through 10/21/2015

**MODEL(S) AFFECTED:**  
All (See affected unit list)

**SUBJECT:**  
Inspection / Correction of Rear Air Deflector Installation

**KEYWORDS:**  
Air Deflector, Deflector, Rear, Spoiler

**ISSUE DATE:**  
August 2019

The purpose of this Recall Service Bulletin is to inform all REV Recreation Group dealers about the need to inspect, and if necessary, install rivets at the mounting plate for the rear air deflector attached to the fiberglass cap on certain model year 2016 American Heritage and model year 2016-2019 American Eagle. A list of the affected motorhomes appears at the end of this Bulletin.

**CONDITION:**

On motorhomes affected by this recall, the center mounting plate for the rear air deflector, located at the top of the rear fiberglass cap, was attached to the fiberglass with screws which, under certain circumstances, can work loose, allowing the rear air deflector to flex and possibly become detached from the vehicle.

If the rear air deflector becomes disconnected from the motorhome, it could present a road hazard which may result in personal injury and/or property damage.

**INSTRUCTIONS:**



Dealers are required to call American Coach Dealer Technical Support before beginning any work and after the unit is in their bay. Prior authorization is required to be submitted. Failure to follow these instructions could result in a denied claim.

American Coach Dealer Technical Support : (800) 417-6413

- **READ THIS ENTIRE BULLETIN CAREFULLY BEFORE PROCEEDING AND FOLLOW ALL SAFETY PRECAUTIONS.**
- **Review the list of affected units at the end of this bulletin to ensure the motorhome you are inspecting is part of this campaign.**
- **Take a copy of this bulletin with you when servicing the unit.**
- **PHOTOS WILL BE REQUIRED FOR THE FOLLOWING PROCEDURES. READ PHOTO REQUIREMENTS CAREFULLY. INSUFFICIENT PHOTO DOCUMENTATION MAY RESULT IN CLAIM DENIAL**
- **If there are any questions after reviewing the entire procedure, contact REV Dealer Technical Support.**



*This bulletin is supplied for technical information only and is not an authorization for repairs.*

Federal law (section 154 of the national traffic and motor vehicle safety act of 1966) requires that: If you have received a notice of recall or failure to comply from REV Recreation Group or any component Manufacturer, you must repair or otherwise correct the defects on vehicles remaining in your inventory, according to the notification, before selling or leasing the vehicles. Any vehicle lessor receiving this recall notice must forward a copy of the notice to the lessee within ten days.

"It is impossible to know, evaluate and advise the service trade of all conceivable ways in which service might be done or of the possible hazardous consequences of each way. Accordingly, anyone who uses a service procedure or tool must first assure that neither personal safety nor vehicle safety will be jeopardized by the selected service methods."

## INSPECTION:

1. Park the motor home on a paved, level surface. Place the transmission into NEUTRAL and engage the parking brake.
2. Turn off the ignition and remove the ignition key. Maintain control of the ignition key until all repairs are completed. Attach a notice, "Do Not Use", to the ignition switch in order to prevent activation of the systems.
3. Block wheels to prevent movement.

## WARNING

**USE FALL PROTECTION WHEN WORKING ON THE ROOF OF A MOTORHOME.**

4. Use a ladder to access the optional 360° camera (if equipped), located behind the rear air deflector. Remove the camera from its mounting bracket using a Phillips screwdriver and 3/8" open end wrench. Leave the camera hang from its cord for the duration of the repair. Set aside the fasteners for reinstallation. See Figures 1 and 2.

**NOTE:** Only the 360° camera needs removed; the standard back-up camera can remain in place.

5. With the properly sized step-ladder and appropriate safety equipment, go onto the roof of the motorhome and locate the rear air deflector. While working on the roof, ensure there is adequate overhead clearance and the proper fall protection is used. See Figure 2.
6. At the center of the air deflector, locate the wire harness running from the top of the fiberglass cap to the three marker lights on the air deflector.
  - a. If the harness has bullet connectors, disconnect the clearance lights from the harness.
  - b. If the harness has butt connectors, cut the wire on the both sides of the connection as close to the butt connector as possible.

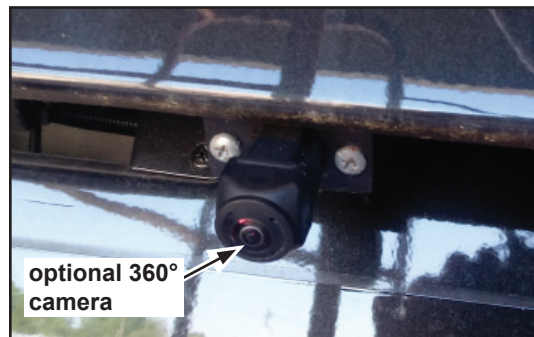

Figure 1

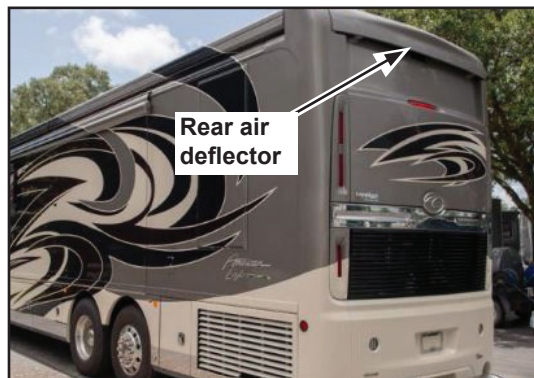

Figure 2

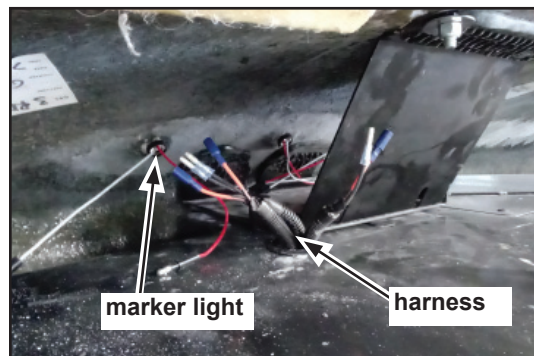

Figure 3

*This bulletin is supplied for technical information only and is not an authorization for repairs.*

Federal law (section 154 of the national traffic and motor vehicle safety act of 1966) requires that: If you have received a notice of recall or failure to comply from REV Recreation Group or any component Manufacturer, you must repair or otherwise correct the defects on vehicles remaining in your inventory, according to the notification, before selling or leasing the vehicles. Any vehicle lessor receiving this recall notice must forward a copy of the notice to the lessee within ten days.

"It is impossible to know, evaluate and advise the service trade of all conceivable ways in which service might be done or of the possible hazardous consequences of each way. Accordingly, anyone who uses a service procedure or tool must first assure that neither personal safety nor vehicle safety will be jeopardized by the selected service methods."

7. While at the center of the air deflector, use a 7/16" socket/ratchet remove the (4) nuts from the top of the mounting bracket located under the air deflector. See Figure 4 for details. Set the nuts and washers aside for reinstallation.
8. Move to the doorside of the coach and locate the lower mounting bracket under the air deflector at the corner of the fiberglass cap. See Figures 5 and 6 for detail. Remove the nut and washer from the mounting bracket stud with a 7/16" socket/ratchet and set them aside for reinstallation.

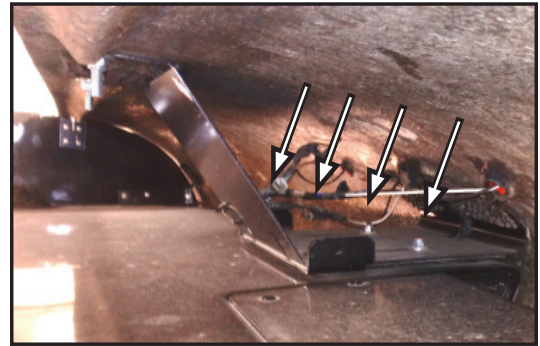

Figure 4

**NOTE: Do not remove any of the rivets at these locations.**

9. Move to the roadside of the coach and locate the lower mounting bracket. Remove the nut and washer from the mounting bracket stud with a 7/16" socket/ratchet and set them aside for reinstallation. This bracket will be located in a similar area as the doorside bracket that was removed in the previous step.

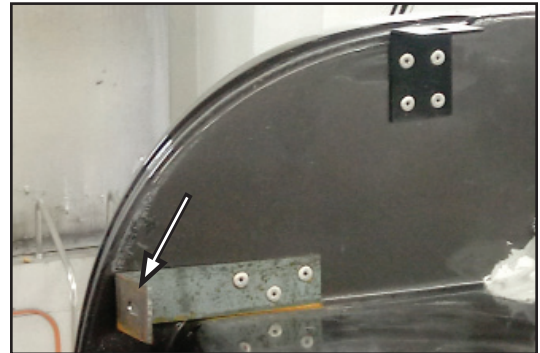

Figure 5

**NOTE: Do not remove any of the rivets at these locations.**

10. While having an assistant on a ladder at the rear of the coach hold the rear air deflector in place, remove the two bolts located at each end of the rear air deflector on the top surface using a 1/2" socket/ratchet and a 1/2" open end wrench. See Figures 7 and 8 for location detail. Set the fasteners aside for reinstallation.

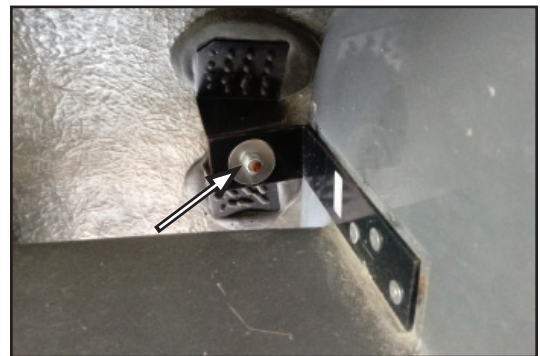

Figure 6

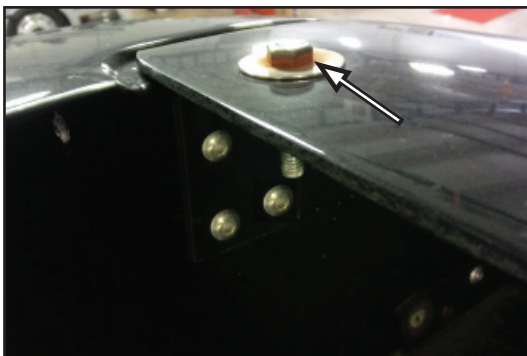

Figure 7

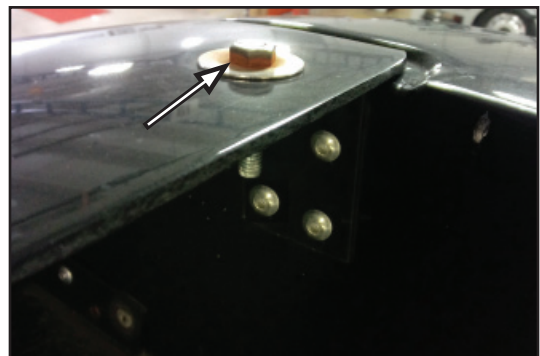

Figure 8

*This bulletin is supplied for technical information only and is not an authorization for repairs.*

Federal law (section 154 of the national traffic and motor vehicle safety act of 1966) requires that: If you have received a notice of recall or failure to comply from REV Recreation Group or any component Manufacturer, you must repair or otherwise correct the defects on vehicles remaining in your inventory, according to the notification, before selling or leasing the vehicles. Any vehicle lessor receiving this recall notice must forward a copy of the notice to the lessee within ten days.

"It is impossible to know, evaluate and advise the service trade of all conceivable ways in which service might be done or of the possible hazardous consequences of each way. Accordingly, anyone who uses a service procedure or tool must first assure that neither personal safety nor vehicle safety will be jeopardized by the selected service methods."

11. Remove the rear air deflector and carefully set aside and secure it on the roof for reinstallation, **taking care to not damage the painted finish.**
12. With the rear air deflector removed, inspect the fasteners holding the center mounting plate to the fiberglass cap.
  - If screws are found (see Figure 9), proceed to Step 13.
  - If rivets are found (see Figure 10), proceed to Step 16.
13. **If screws were found** in the previous step, remove them from the plate and discard them as they will not be reused.

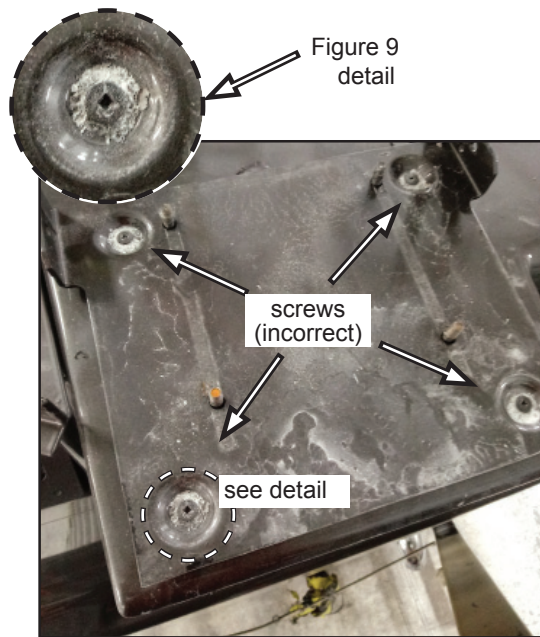

Figure 9

14. With the plate removed, temporarily turn it over so that the studs are facing down. Around each mounting “foot”, apply a 1/8” bead of Sikaflex®-221 or 3M™ #540 adhesive. See Figure 11.
15. Return the plate to its original position so that the studs are pointed up and the tabs are towards the front of the unit. Position it over the existing holes in the fiberglass cap. Secure the plate to the fiberglass cap using the 3/16 rivets included in the parts kit.

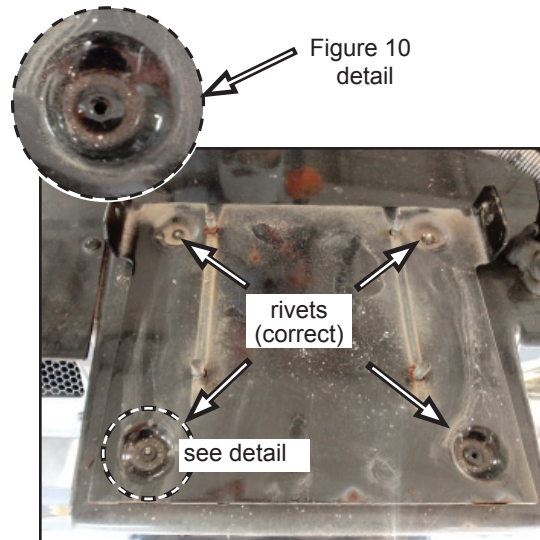

Figure 10

**NOTE:**

- Use the holes that were originally used for the screws; if other holes are present, they should not be used.
- It may be necessary to drill out the holes in the fiberglass cap to 1/4” for the rivets to properly fit.

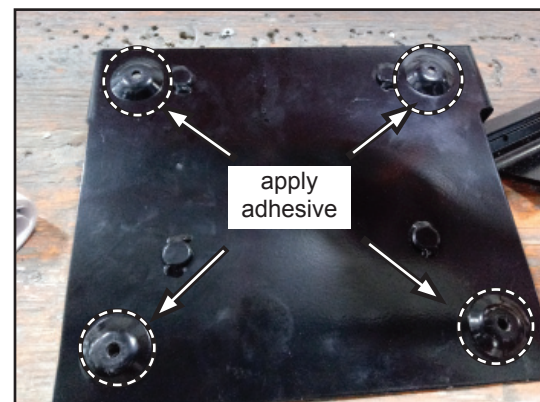

Figure 11

*This bulletin is supplied for technical information only and is not an authorization for repairs.*

Federal law (section 154 of the national traffic and motor vehicle safety act of 1966) requires that: If you have received a notice of recall or failure to comply from REV Recreation Group or any component Manufacturer, you must repair or otherwise correct the defects on vehicles remaining in your inventory, according to the notification, before selling or leasing the vehicles. Any vehicle lessor receiving this recall notice must forward a copy of the notice to the lessee within ten days.

"It is impossible to know, evaluate and advise the service trade of all conceivable ways in which service might be done or of the possible hazardous consequences of each way. Accordingly, anyone who uses a service procedure or tool must first assure that neither personal safety nor vehicle safety will be jeopardized by the selected service methods."

16. With the help of an assistant, position the rear air deflector so that the studs align with their appropriate mounting brackets.
17. While the assistant holds the rear air deflector in its correct location, install the two bolts that were removed in Step 10.  
**NOTE:** Do not tighten the bolts at this time; leave loose until all other fasteners are installed.
18. At the roadside of the coach, verify that the stud is properly seated in the lower bracket and install the 7/16" nut and washer that was removed in Step 9. Torque this fastener to 50-60 in-lbs. If locking nuts are not present, apply Loctite® Threadlocker Blue 242® to the threads prior to tightening.
19. Move to the doorside of the coach, verify that the stud is properly seated in the lower bracket and install the 7/16" nut and washer that was removed in Step 8. Torque this fastener to 50-60 in-lbs. If locking nuts are not present, apply Loctite® Threadlocker Blue 242® to the threads prior to tightening.
20. At the center mounting bracket, install the four 7/16" nuts and washers that were removed in Step 7. Torque these fasteners to 50-60 in-lbs. If locking nuts are not present, apply Loctite® Threadlocker Blue 242® to the threads prior to tightening.
21. Torque the two bolts, installed in Step 17, to 17-20 ft-lbs. If locking nuts are not present, apply Loctite® Threadlocker Blue 242® to the threads prior to tightening. See Figure 12 for a summary of torque specifications.

**NOTE:** Ensure all fasteners and torques are double checked before completing the procedure.

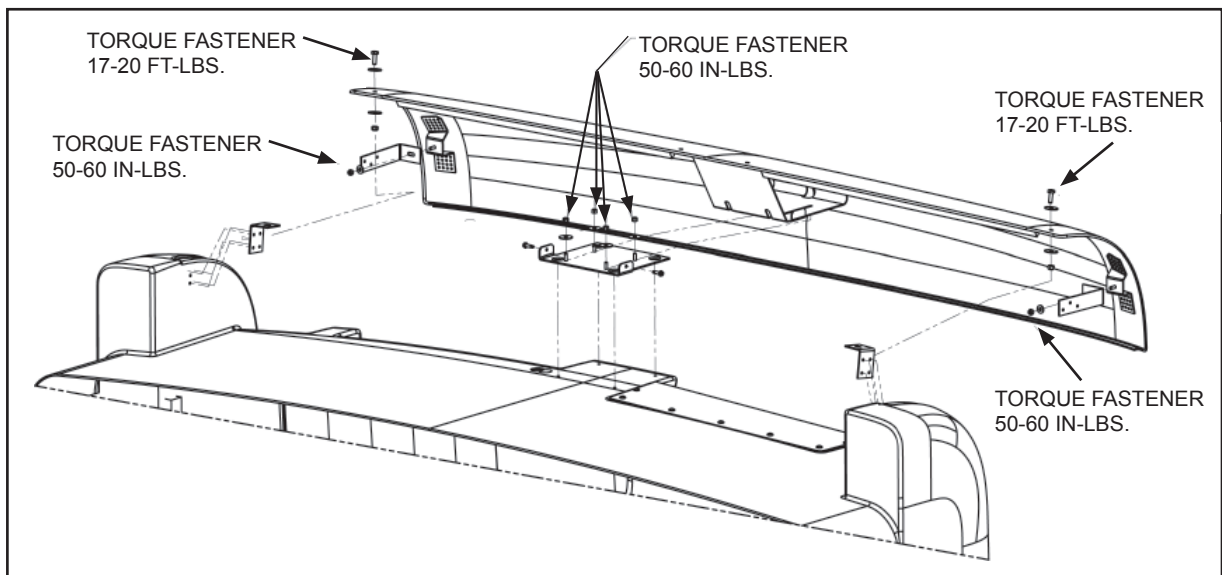
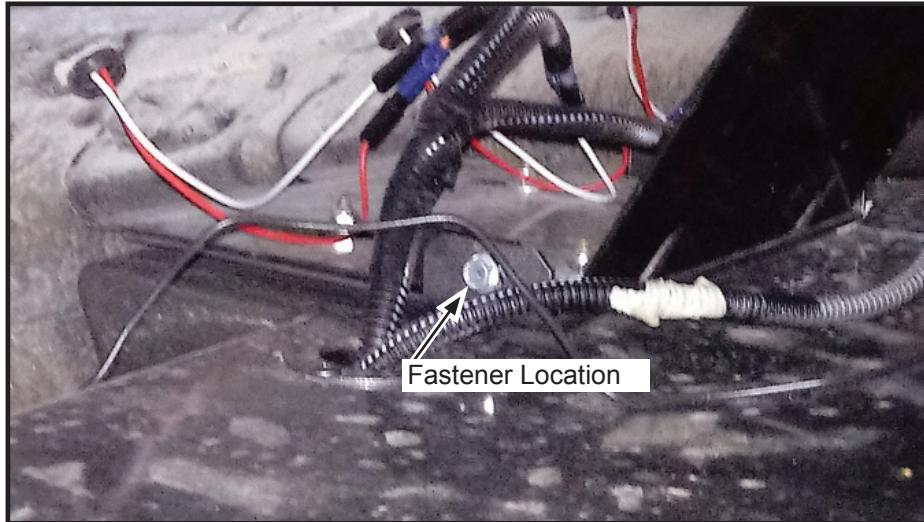

**Figure 12**

*This bulletin is supplied for technical information only and is not an authorization for repairs.*

Federal law (section 154 of the national traffic and motor vehicle safety act of 1966) requires that: If you have received a notice of recall or failure to comply from REV Recreation Group or any component Manufacturer, you must repair or otherwise correct the defects on vehicles remaining in your inventory, according to the notification, before selling or leasing the vehicles. Any vehicle lessor receiving this recall notice must forward a copy of the notice to the lessee within ten days.

"It is impossible to know, evaluate and advise the service trade of all conceivable ways in which service might be done or of the possible hazardous consequences of each way. Accordingly, anyone who uses a service procedure or tool must first assure that neither personal safety nor vehicle safety will be jeopardized by the selected service methods."



**Figure 13**

22. Using the two 1/4" HWH self-drilling screws, included in the parts kit, fasten through the center mounting plate tabs into the bracket attached to the rear air deflector at the location shown in Figure 13. The doorside is shown; the roadside is similar.
23. After the proper torque has been applied to all the fasteners, reconnect the wire harness (disconnected in Step 6) to the upper marker lights.
  - a. If bullet connectors were used, reconnect the lights using the existing connectors.
  - b. If butt connectors were used, appropriately strip the wires and install new butt connectors. It is possible that the wires may be too short in order to correctly reconnect the harness to the lights. If the wiring is too short, add a short length (6"-8") of 14 gauge jacketed wire so that there is no strain on the butt connections.
24. If the unit is equipped with the optional 360° camera, reinstall it with the fasteners that were removed in step 4.
25. Test the function of the rear clearance lights and 360° camera (if equipped); correct if necessary. When proper function is verified, the repair is complete.

*This bulletin is supplied for technical information only and is not an authorization for repairs.*

Federal law (section 154 of the national traffic and motor vehicle safety act of 1966) requires that: If you have received a notice of recall or failure to comply from REV Recreation Group or any component Manufacturer, you must repair or otherwise correct the defects on vehicles remaining in your inventory, according to the notification, before selling or leasing the vehicles. Any vehicle lessor receiving this recall notice must forward a copy of the notice to the lessee within ten days.

"It is impossible to know, evaluate and advise the service trade of all conceivable ways in which service might be done or of the possible hazardous consequences of each way. Accordingly, anyone who uses a service procedure or tool must first assure that neither personal safety nor vehicle safety will be jeopardized by the selected service methods."

**PARTS:**

Purchase through REV Parts or obtain locally:

<u>Part Number</u>	<u>Description</u>	<u>Qty.</u>
10007847	3/16" Oscar/Molly style rivets (pictured at right)	4
10089470	Screw, Tek, 1/4-20 HWH Plated	2



Oscar/Molly style rivet

**Obtain locally:**

Sikaflex®-221 or 3M™ #540 adhesive  
Loctite® Threadlocker Blue 242®

**TOOLS:**

7/16" Socket	Power driver
1/2" Socket	Driver bits
1/2" Open end wrench	Phillips screwdriver
3/8" Open end wrench	Rivet tool
Ratchet	Caulk gun
Torque wrench (inch-pounds)	Flashlight
Torque wrench (foot-pounds)	Wheel chocks

**WARRANTY LABOR ALLOWANCE:**

Recall 190709REV, Rear Air Deflector Installation

Use flat rate codes:

6084 - 11	Inspected/Not Defective	0.9 hr.	Prior Authorization Required
6084 - 12	Inspected/Defective/Repaired	1.0 hr.	Prior Authorization Required

*If you have any questions concerning this bulletin, contact  
American Coach Dealer Technical Support:*

**(800) 417-6413**

*Service Literature is available at: <http://www.revrdealers.com>*

*This bulletin is supplied for technical information only and is not an authorization for repairs.*

Federal law (section 154 of the national traffic and motor vehicle safety act of 1966) requires that: If you have received a notice of recall or failure to comply from REV Recreation Group or any component Manufacturer, you must repair or otherwise correct the defects on vehicles remaining in your inventory, according to the notification, before selling or leasing the vehicles. Any vehicle lessor receiving this recall notice must forward a copy of the notice to the lessee within ten days.

"It is impossible to know, evaluate and advise the service trade of all conceivable ways in which service might be done or of the possible hazardous consequences of each way. Accordingly, anyone who uses a service procedure or tool must first assure that neither personal safety nor vehicle safety will be jeopardized by the selected service methods."