

<b>REFERENCE:</b>	Nova Bus Manuals
<b>SECTION:</b>	12: Passenger Seats
<b>RS N°:</b>	MQR 7621-1275
<b>EFFECTIVE IN PROD.:</b>	LC67(2019SE)
<b>TC RECALL N°:</b>	2019-332
<b>NHTSA RECALL N°:</b>	19V511

**APPLICATION DEADLINE:** NA  
**CLAIM REFERENCE NUMBER:** SR-4663

<b>SUBJECT:</b>	Cantilever-type passenger seat anchor rails
<b>JUSTIFICATION:</b>	Hardware used to secure some cantilever seats may not have been properly tightened.

LEVEL	DESCRIPTION	DIRECT CHARGES		TIME
		LABOUR	MATERIAL	
1	1- Inspect the seat's upper anchor rail and the hardware that affixes the seat to the upper anchor rail. 2- Replace the upper support brackets of all cantilever-type, two- passenger seats with no stanchion affixed to the backrest.	Nova Bus	Nova Bus	3h45
2	Replace all damaged seat rails and the hardware	Nova Bus	Nova Bus	3h

#### REVISION HISTORY

REV.	DATE	CHANGE DESCRIPTION	WRITTEN BY
NR	2019OC04	Initial release	Luc Carignan
R1	2019OC21	Document in revision. New version to be release shortly	Luc Carignan
R2	2019NO22	Client list change. Installation of a new upper support bracket on all cantilever-type two-passenger seats is now required.	Luc Carignan

**APPROVED BY:**

Jean-Nicolas Fournier

Digitally signed by Jean-Nicolas Fournier  
 DN: cn=Jean-Nicolas Fournier, o=Nova Bus, email=jean-nicolas.fournier@volvo.com, c=CA  
 Date: 2019.11.22 13:16:11 -05'00'

PAGE 1 OF 17

**MATERIAL**

QTY	PART N°	REV.	DESCRIPTION	REPLACES PART N°
<b>LEVEL 1</b>				
5	N8910245-BS	–	Upper support bracket	–
5	N8910246-BS	–	L-bracket	–
30	N44620-02	–	T-bolts	–
30	N37109	–	Serrated flanged nut	–
15	N17575	–	M6 washer	–
15	N44689	–	M6 lockwasher	–
15	500387	–	M6 bolt	–
<b>LEVEL 2 (only if required*)</b>				
1	N59740	–	Middle RH narrow upper anchor rail	–
1	N59741	–	Middle LH upper anchor rail	–
1	N59742-1	–	LH rear upper anchor rail	–
1	N59742-2	–	RH rear upper anchor rail	–
1	N59743	–	Middle RH upper anchor rail	–
1	N59744	–	Front RH upper anchor rail	–
1	N71177-1	–	Rear LH upper anchor rail	–
1	N71177-2	–	Rear RH upper anchor rail	–
40	N11344	–	M10 X 35 Allen screw	–
20	N44620-02	–	T-bolt	–
20	N37109	–	Serrated flanged nut	–

Materials will be available within 73 days once your order has been placed. To order, please contact Prevost Parts by phone at 1-800-771-6682, by fax at 1-888-668-2555 or by email at [prevostparts.commandes@volvo.com](mailto:prevostparts.commandes@volvo.com). Specify document number, quantity of parts required and shipping address.

\* The material identified in Level 2 is to be ordered only for vehicles that meet the criteria defined in Level 1.

**CONSULT YOUR PART MANUAL TO KNOW WHICH OF THE PARTS LISTED IN LEVEL 2 IS REQUIRED FOR YOUR VEHICLE.**

**DISPOSAL OF PARTS**

REMOVED PARTS ARE:	DISCARDED*	RETAINED	* Dispose of the unused parts and the defective parts in accordance with local environmental standards in effect.
	Yes	–	

Symbol	Meaning
Empty Field	No changes, the procedure applies
+	Contract added, the procedure applies
Transfer to CRXXXX	Contract removed and transfer to another CR document

R2	CLIENT	ORDER	ROAD NUMBER		VIN (2NVY/4RKY...)		QTY
			FROM	TO	FROM	TO	
Transfer to CR4741	Austin - CMTA - Texas	L704	5051	5068	L82J7E4500471	L82J2E4500488	18
+	Burlington - Ontario	LB35	7033-18	7036-18	L82J9J3751432	L82J0J3751433	2
Transfer to CR4742	Brampton - Ontario	L789	1401	1408	L82J4E3001216	L82J1E3001223	8
Transfer to CR4742	Brampton - Ontario	L864	1501	1510	L82JXF3001500	L82J6F3001509	10
Transfer to CR4742	Brampton - Ontario	L865	1511	1519	L82JXF3001514	L82J9F3001522	9
+	Calgary Transit - Alberta	L733	8201	8202	L82AXD3000926	L82A1D3000927	2
Transfer to CR4744	Halifax - Nova Scotia	LA11	1208	1236	L82J1G9775579	L82J4G9775608	29
+	Halifax - Nova Scotia	LA14	1237	1237	L82J1G9775596	L82J1G9775596	1
+	Halifax Nova Scotia	LC11	1300	1334	L82JXK9777310	L82J5K9777344	35
+	Houston - Texas	LB63	2050	2050	L82K2J9776708	L82K2J9776708	1
+	Houston - Texas	LB72	2051	2069	L82K6J9776887	L82K4J9776905	19
+	Houston Texas - Metro	LC55	2070	2079	L82KXK9777378	L82K0K9777387	10
+	Lethbridge - Alberta	L868	—	—	L82J2F3001510	L82J2F3001510	1
+	Milton - Ontario	LB33	1804	1804	L82J7J3751543	L82J7J3751543	1
+	Milton - Ontario - Metrolinx	L884	1701	1702	L82J0G3750338	L82J2G3750339	2
	Milton - Ontario - Metrolinx	LA51	1801	1803	L82J3H3750917	L82J7H3750919	3
+	Oakville - Ontario	LB93	—	—	L82J3K3751749	L82J5K3751753	5
+	Oakville Ontario	LC57	—	—	L82J6K3752121	L82J5K3752126	6
	San Antonio Texas	LA10	422	446	L82K9G9775628	L82K8G9775653	25
	San Antonio Texas	LA22	447	555	L82K8H9775654	L82K0H9775762	109
	San Antonio Texas	LA34	556	580	L82K0H9775857	L82K8H9775881	25
	San Antonio Texas	LA35	581	691	L82KXH9775882	L82K8H9775993	111
+	San Antonio Texas	LB26	692	735	L82KXJ9776536	L82K6J9776579	44
+	SolTrans Solano County Transit California - CNG	L990	-	-	L82K5G9775464	L82K5G9775464	1
Transfer to CR4746	SEPTA - Pennsylvania	L742	7371	7414	S92L6E4500729	S92L7E4500772	44
Transfer to CR4744	SEPTA - Pennsylvania	L744	8601	8689	L82L7E4500570	L82LXE4500661	89
	St. John's - Newfoundland	L731	1310	1314	L82U3C3000842	L82U2C3000847	5
	St. John's - Newfoundland	L808	1415	1419	L82J4E3001152	L82J1E3001156	5
	St. John's - Newfoundland	L875	1520	1525	L82JXF3001478	L82J3F3001483	6
	St. John's - Newfoundland	L930	1626	1630	L82J7F3001826	L82J9F3001830	5

Symbol	Meaning
Empty Field	No changes, the procedure applies
+	Contract added, the procedure applies
Transfer to CRXXXX	Contract removed and transfer to another CR document

R2	CLIENT	ORDER	ROAD NUMBER		VIN (2NVY/4RKY...)		QTY
			FROM	TO	FROM	TO	
Transfer to CR4742	Sudbury - Ontario	L890	851	855	L82JXF3001609	L82J6F3001641	5
Transfer to CR4742	Sudbury - Ontario	L994	861	865	L82J1G3750364	L82J9G3750368	5
Transfer to CR4742	Sudbury - Ontario	LA46	871	873	L82J1H3750821	L82J5H3750823	3

**WARNING**

FOLLOW YOUR INTERNAL SAFETY PROCEDURES.

## PROCEDURE

### LEVEL 1:

#### 1.1- INSPECT THE SEATS' UPPER ANCHOR RAILS AND THE HARDWARE THAT AFFIXES THE SEATS TO THE UPPER ANCHOR RAILS.

- 1.1. Visually inspect all the upper anchor rails located between the front wheelhouses and the rear of the vehicle for any cracks and/or deformities. See Figure 1.
  - a. If any cracks and/or deformities are visible on the top anchor rails, go to step 2.1. If no defect are found after inspection, proceed with the next step of the level 1 procedure.

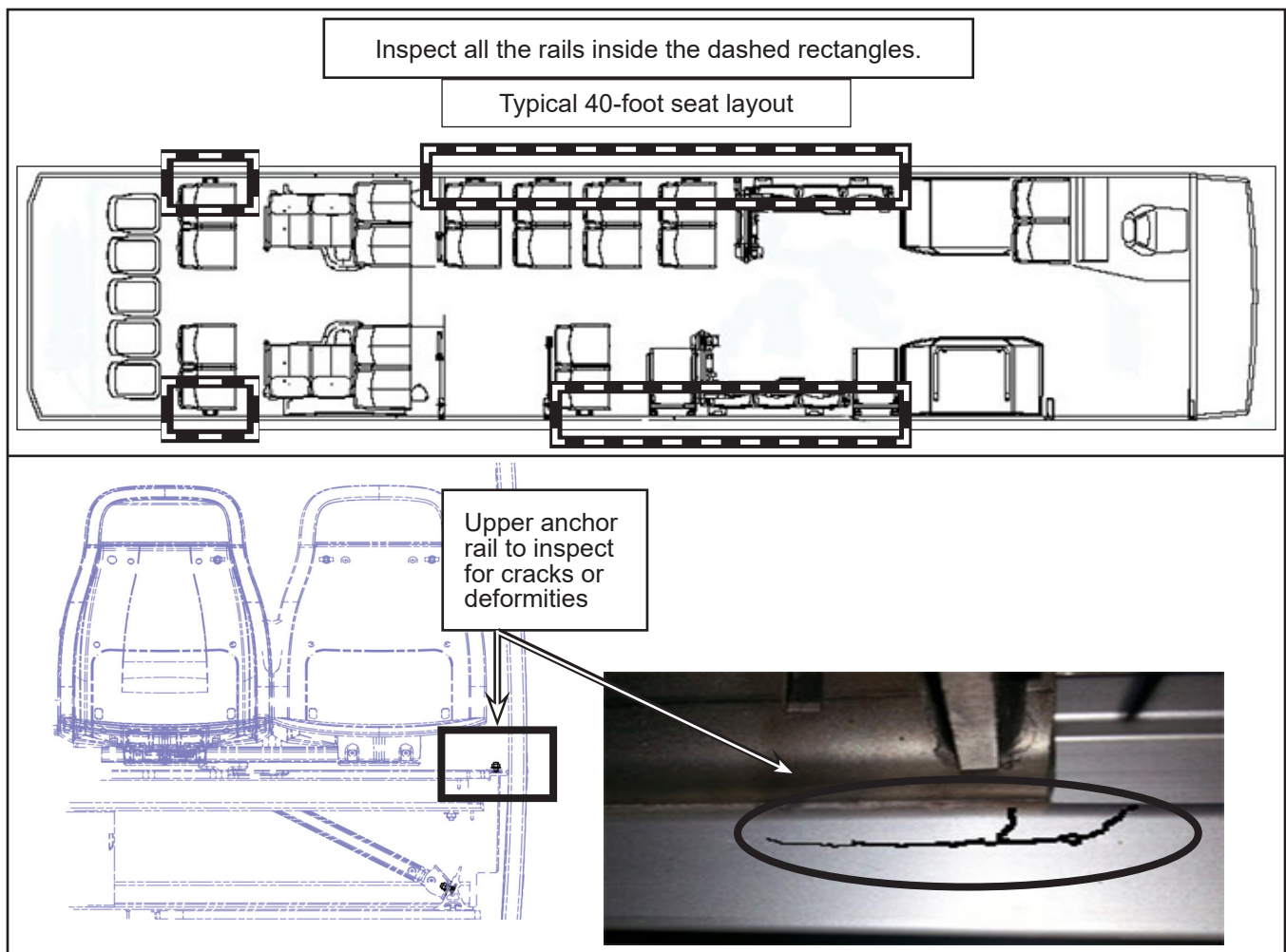

Figure 1 - Inspection Seats' Upper Rail

## 1.2- REPLACE THE UPPER SUPPORT BRACKETS OF ALL THE CANTILEVER-TYPE TWO-PASSENGER SEATS WITH NO STANCHION AFFIXED TO THE BACKREST



### NOTE

When removing any passenger seat and/or seat belts from the anchor rail, all T-bolts and nuts should be discarded and never be reused to affix a passenger seat or seat belt.

- 1.2. For all cantilever-type two passenger seats with no stanchion affixed to the backrest, follow steps a-q to replace the upper support bracket
  - a. Place tape on each side of the lower anchor bracket. Place tape on the wall to align with the middle of the top support bracket. See Figure 2.
  - b. If required, disconnect any electrical harness connected to an electrical device on the seat frame and remove the tie wraps. See Figure 2.

a - Place tape on each side of the lower anchor bracket or brackets. Place tape on the wall to align with the middle of the top support bracket.

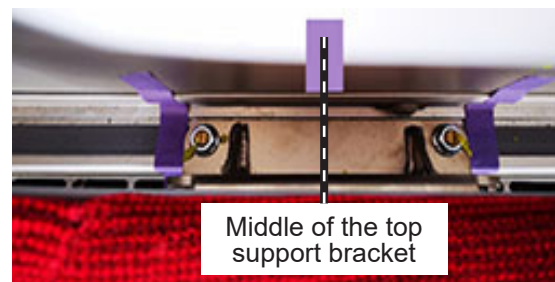

Middle of the top support bracket

b - Typical electrical harness to disconnect and remove



Figure 2 - Steps to do Before Seat Removal

- c. Remove the cantilever-type two passenger seats with no stanchion affixed to the backrest from the seat anchor rail. Remove all T-bolts and nuts from the upper and lower anchor rails. Dispose of all the removed T-bolts and nuts. See Figure 3.

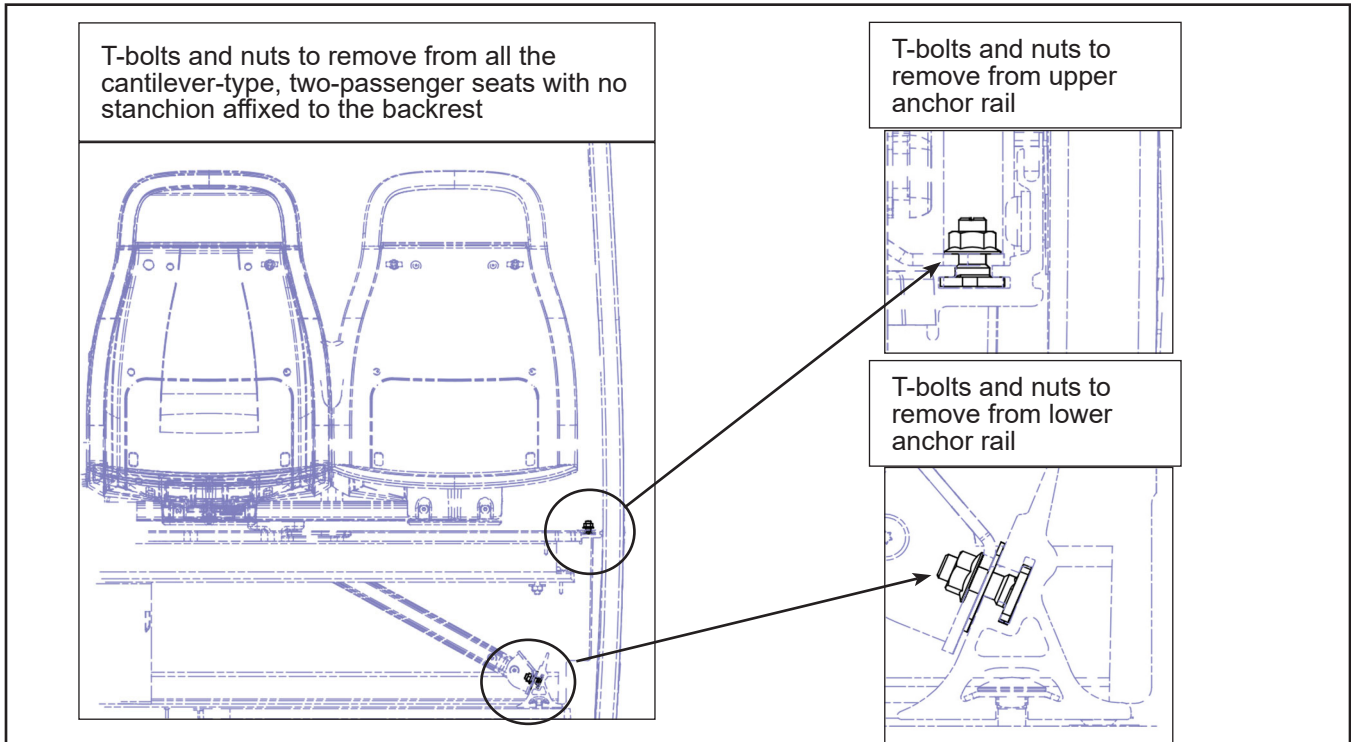

Figure 3 - T-bolts and Nuts to remove

- d. Remove the upper support bracket from all the removed cantilever-type seats. Retain the hardware. See Figure 4.

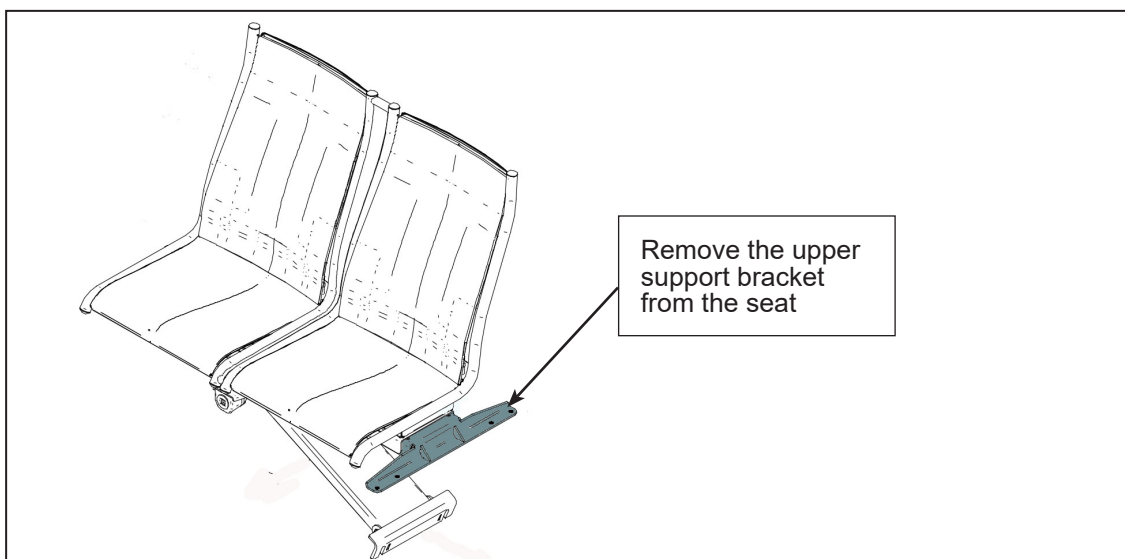

Figure 4 - Typical Upper Support Bracket to Remove

- e. Install a new upper support bracket N8910245-BS on all the removed two-passenger seats using the retained hardware. See Figure 5 for installation details and torque value.

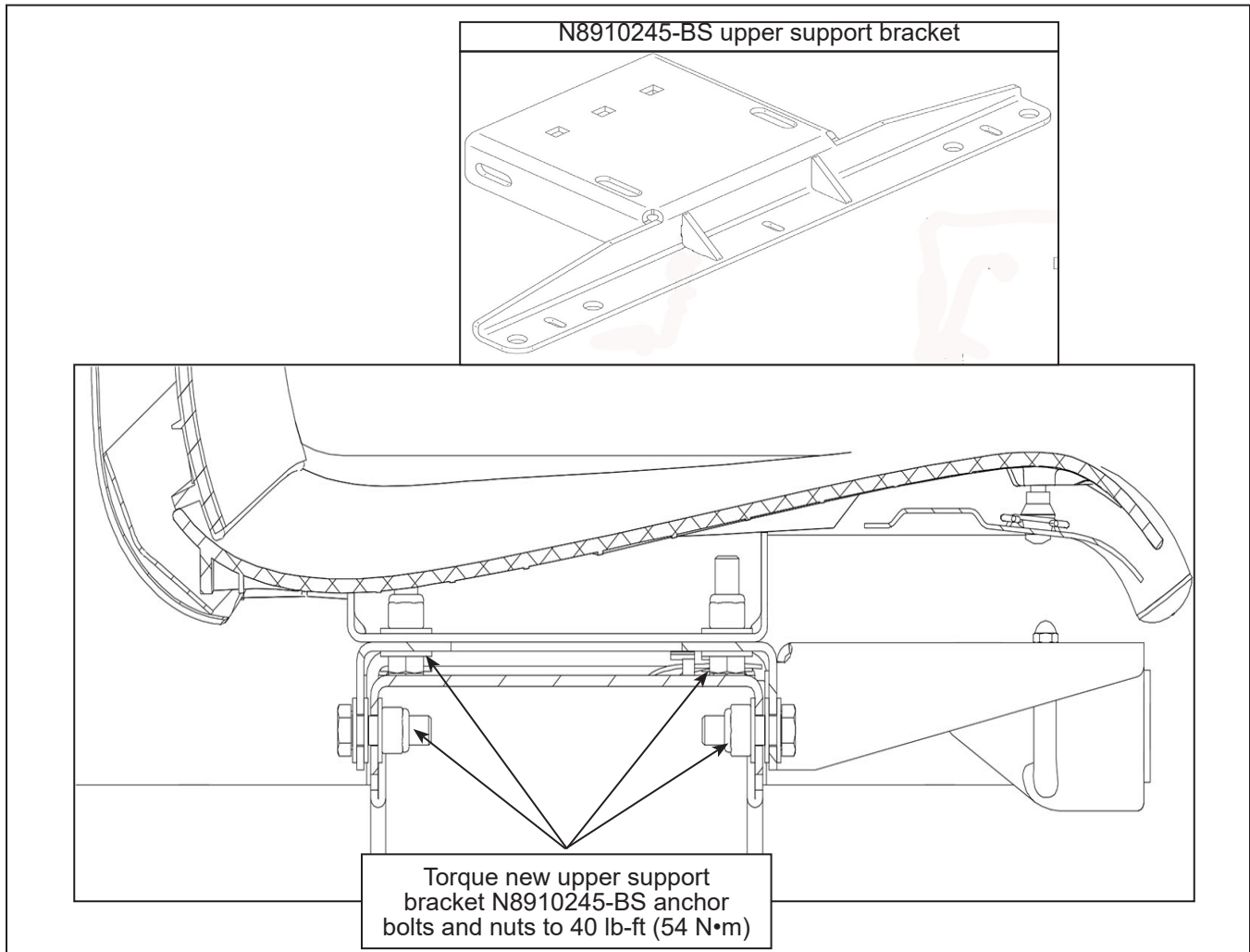

Figure 5 - Upper Support Bracket N8910245 Torque Value

- f. Visually inspect all the upper anchor rails where the seats were supported for any sign of cracks and/or deformities. If any cracks and/or deformities are present, proceed with level 2. If the upper anchor rail show no cracks and/or deformities, finish the level 1 procedure and return the vehicle to service.



- g. Place L-bracket N8910246-BS on the upper anchor rail and position the middle hole of the L-racket in line with the tape on the wall. Mark the rubber filler strip on each side of the L-bracket. Repeat this step for all removed seats.
- h. Remove L-bracket N8910246-BS and cut the portion of rubber filler strip that was under the L-bracket. Repeat this operation for all removed seats.
- i. Install 6 N44620-02 T-bolts in the anchor rail for each removed seat. See Figure 6.

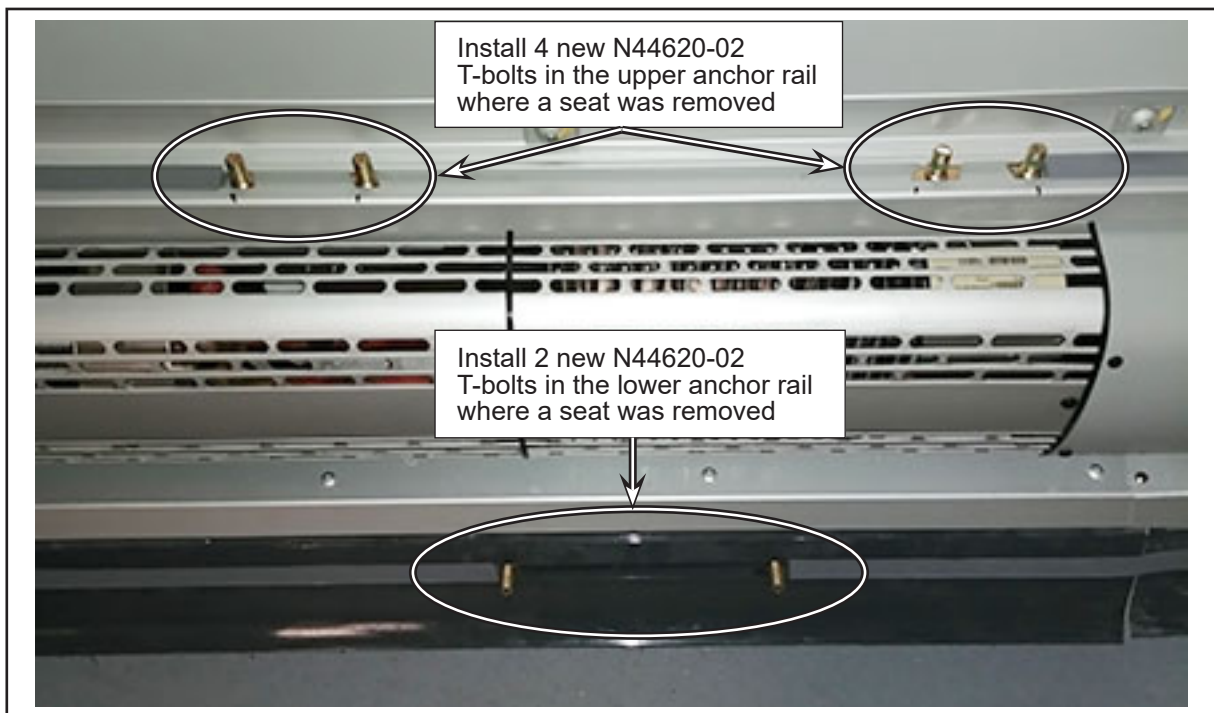

Figure 6 - Position of N44620-02 T-bolts

- j. Install all the N8910246-BS L-bracket on the N44620-02 T=Bolts installed in the upper anchor rail. See Figure 7.
- k. Install the removed seat(s) on the N8910246-BS L-bracket and the N44620-02 T-bolts installed in lower anchor rail. See Figure 7.

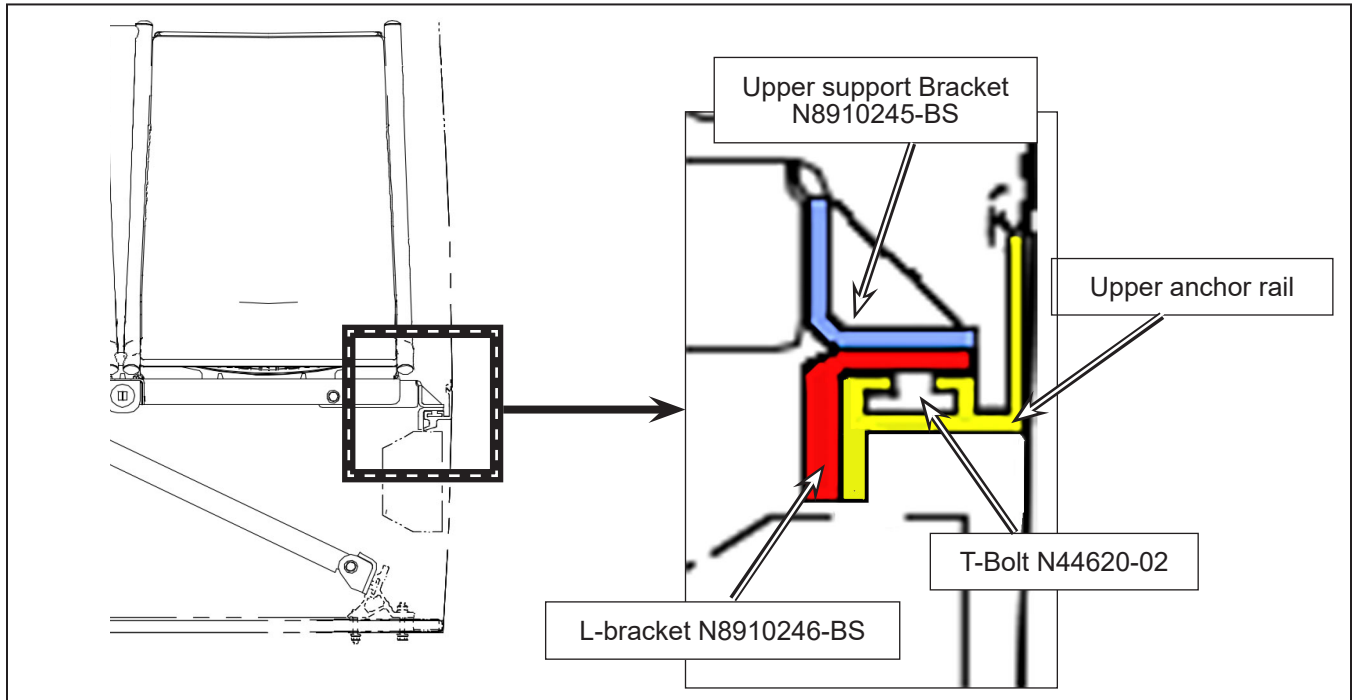

Figure 7 - Installation of L-bracket N8910246-BS

- i. Hand tighten the N37109 serrated flange nuts on all the T-bolts that affix the removed seat(s) to the upper and lower anchor rail. Make sure the puncture in the T-bolts is facing the center of the vehicle. See Figure 8.
- m. Push the N8910246-BS L-bracket toward the upper anchor rail, make sure there is full contact between the L-bracket and the upper anchor rail, and torque the N37109 serrated flanged nut. See Figure 8 for torque value.
- n. With a torque wrench, torque the T-bolts on the lower rail See Figure 8 for torque value.

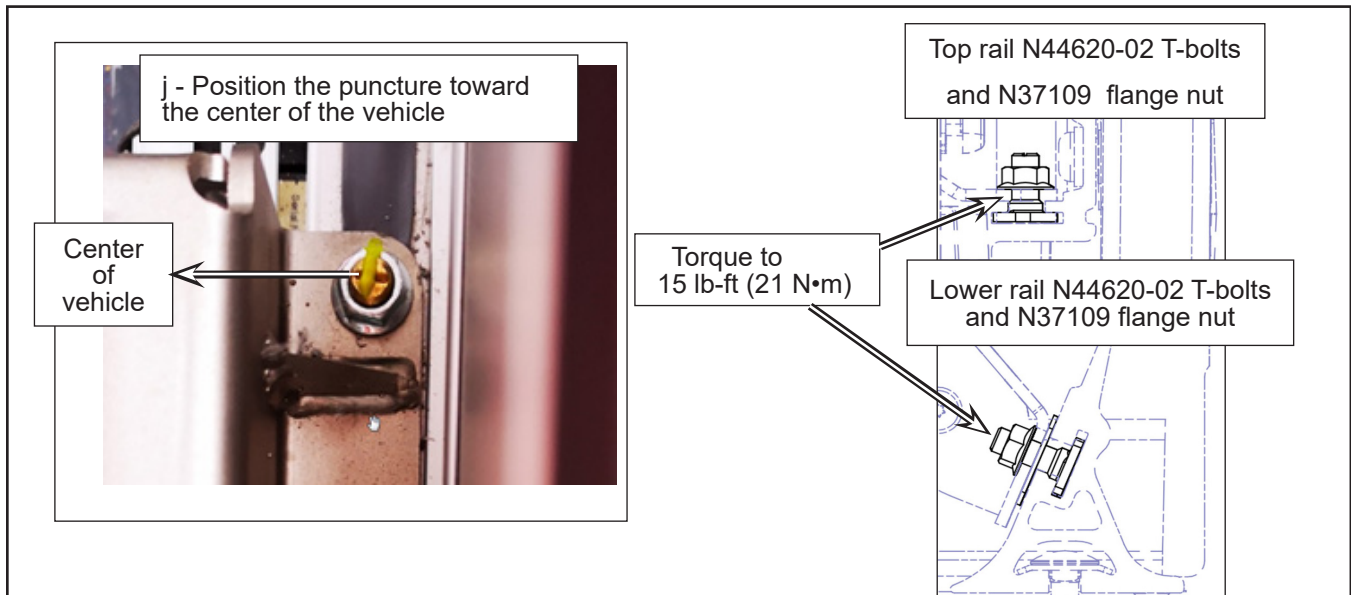

Figure 8 - T-bolt Puncture Alignment and Torque Value

- o. Fix the upper support bracket to the L-bracket with 500387 bolts, N44689 lock washer and N17575 washers. Tighten the screws with a screwdriver. See Figure 9.

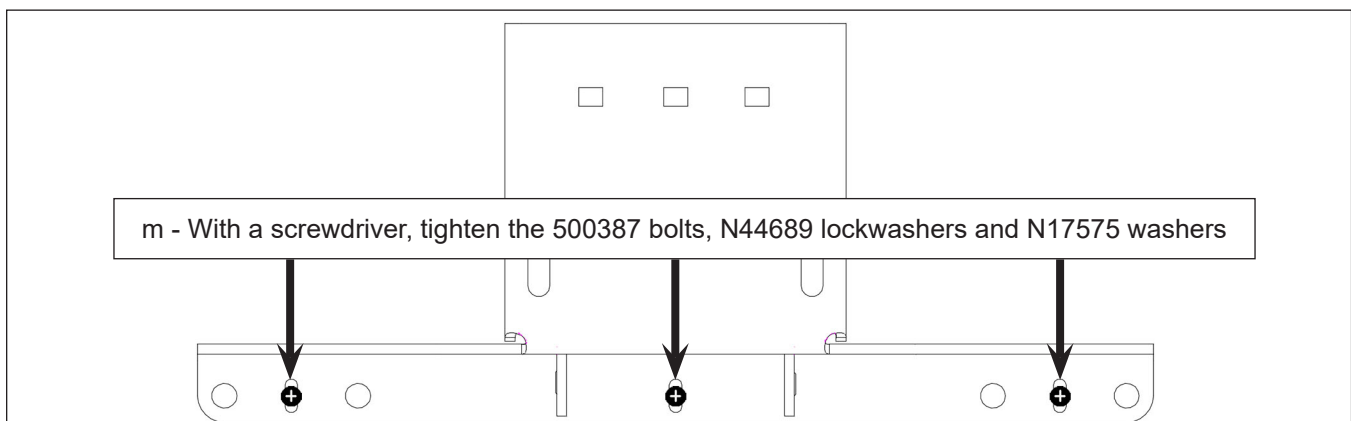
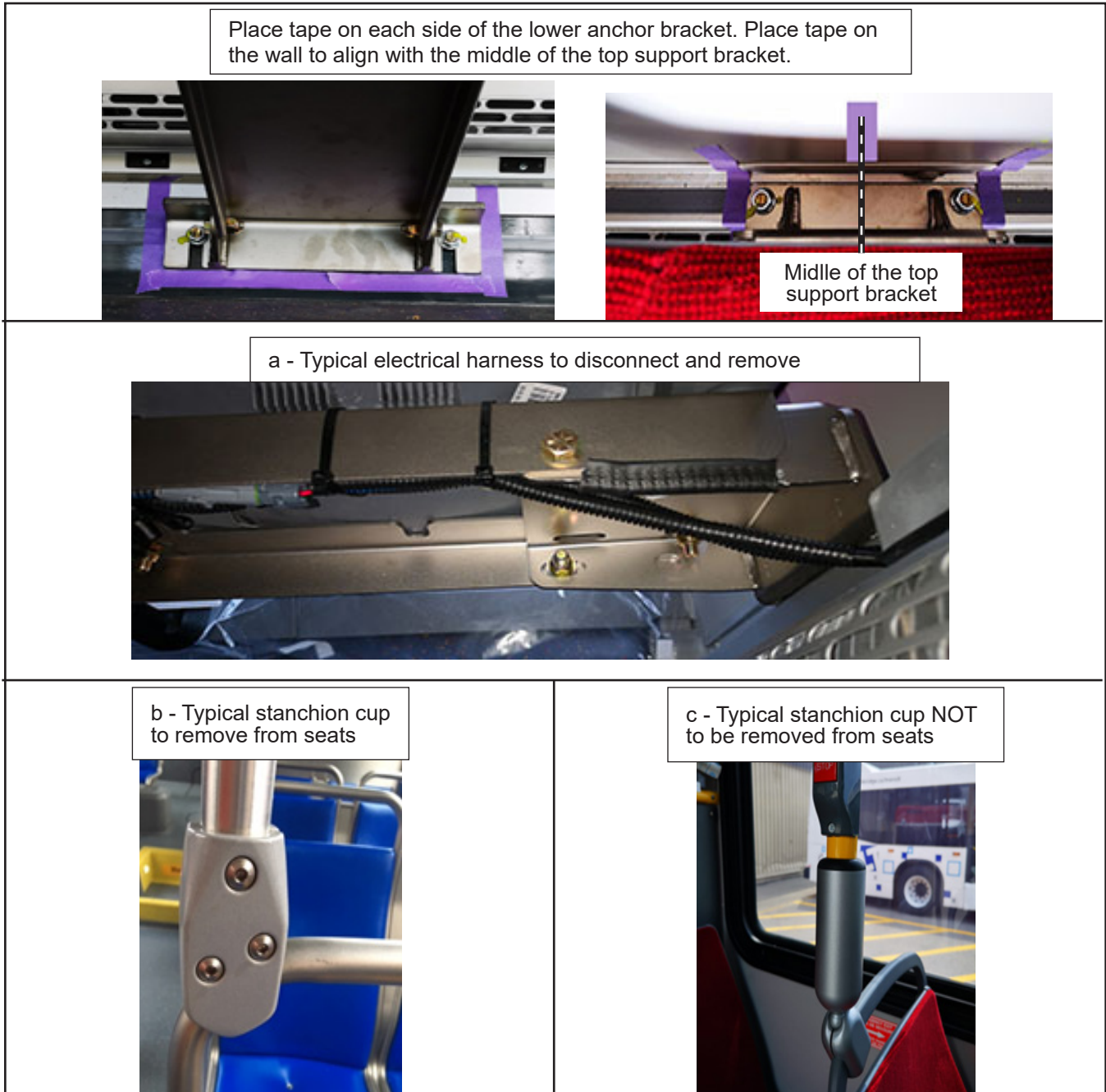

Figure 9 - Upper Support Bracket Top Affixed to L-bracket

- p. If required, connect the electrical component underneath the seat and secure the electrical harness with tie wrap.
- q. Remove the tape.

**LEVEL 2: REPLACE ALL THE DAMAGED SEAT RAILS AND HARDWARE**

- 2.1. For all seats affixed to the defective upper anchor rail, place tape on each side of the lower anchor bracket. Place tape on the wall to align with the middle of the top support bracket. See Figure 10.,
  - a. If required, disconnect any electrical harness connected to an electrical device on the seat frame and remove the tie wraps. See Figure 10.
  - b. If a seat has a stanchion bolted to the backrest, remove the anchor cup from the backrest. Retain the cup and hardware. Do not remove the stanchion. See Figure 10.
  - c. If a seat has a cup-style stanchion, do not remove the stanchion cup; the stanchion can be disconnected when the seats will be lowered. See Figure 10.



*Figure 10 - Steps to Perform Before Seat Removal*

- d. Remove the seats from the seat anchor rail and remove all T-bolts and nuts from the upper and lower anchor rails. Dispose of all the removed T-bolts and nuts.
- e. If equipped with an accessibility seat belt on the top anchor rail, put tape on the wall on each side of the seat belt.
- f. Cut and remove the sealer installed at each end of the rail. See Figure 11.
- g. Number the rubber filler strips installed on the upper anchor rail before removing them. Remove the numbered rubber filler strips. Retain all the rubber filler strips. See Figure 11.

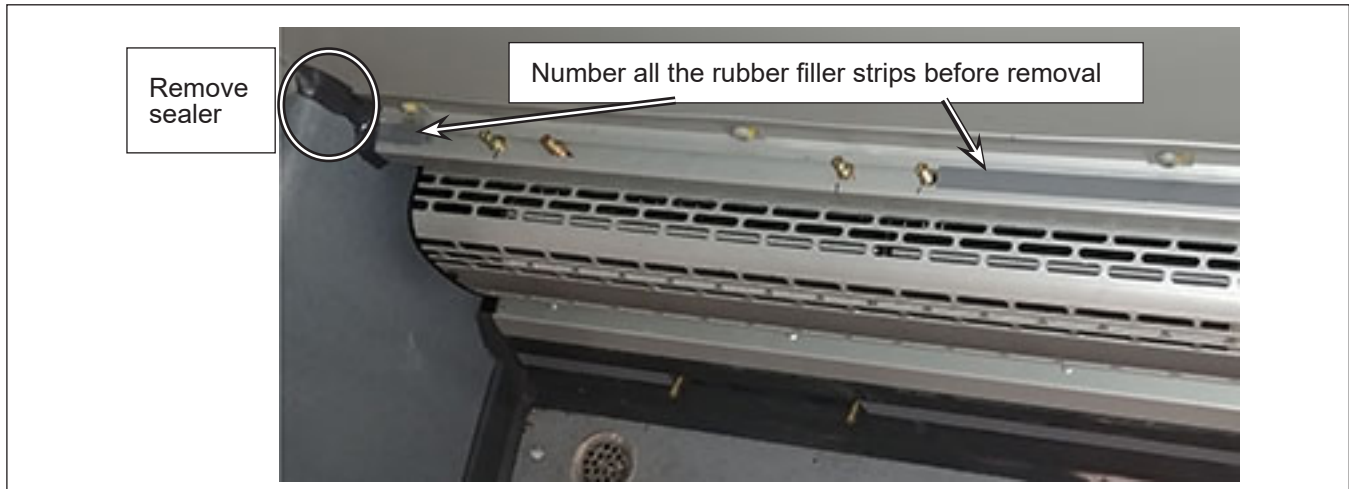

Figure 11 - Typical Anchor Rail, Rubber Filler Strips and Sealer

- h. With a manual tool, remove the top anchor rail M10 anchor bolts and rectangular washers. Be careful not to strip the wall rivnuts while removing the anchor bolts. Discard the bolts and retain the rectangle washer. See Figure 12.
- i. Remove the upper anchor rail by pulling the bottom of the rail toward the center of the vehicle. Dispose of the removed anchor rail.



Figure 12 - M10 Bolts and Rectangular Washers to Remove

- j. With an M10 X 1.5 tapping tool and thread cleaner, carefully clean all the rivnuts used to affix the upper anchor rail.
- k. Install the new upper anchor rail (see the parts list and refer to your parts manual for the parts to order).
- l. Apply Loctite 242 (Nova Bus part number 9985283) or the equivalent, to each new N11344 M10 bolts. See Figure 13.
- m. To install the new upper anchor rail in position, hand tighten the new N11344 M10 bolts with the retained rectangular washers. See Figure 13.
- n. With a torque wrench, apply the torque indicated in Figure 13 to all upper anchor rail M10 bolts. Follow a linear order from back to front to torque the M10 bolts.
- o. Apply the torque a second time to each new N11344 M10 bolts affixing the upper anchor rail. See Figure 13 for torque value.

**CAUTION**

If any of the wall rivnuts spin while applying torque to the bolt, try to tighten in place with a nutsert tool. If unable to tighten in place, remove the upper anchor rail and replace the defective rivnut(s). Refer to your parts manual for the proper rivnuts to use.

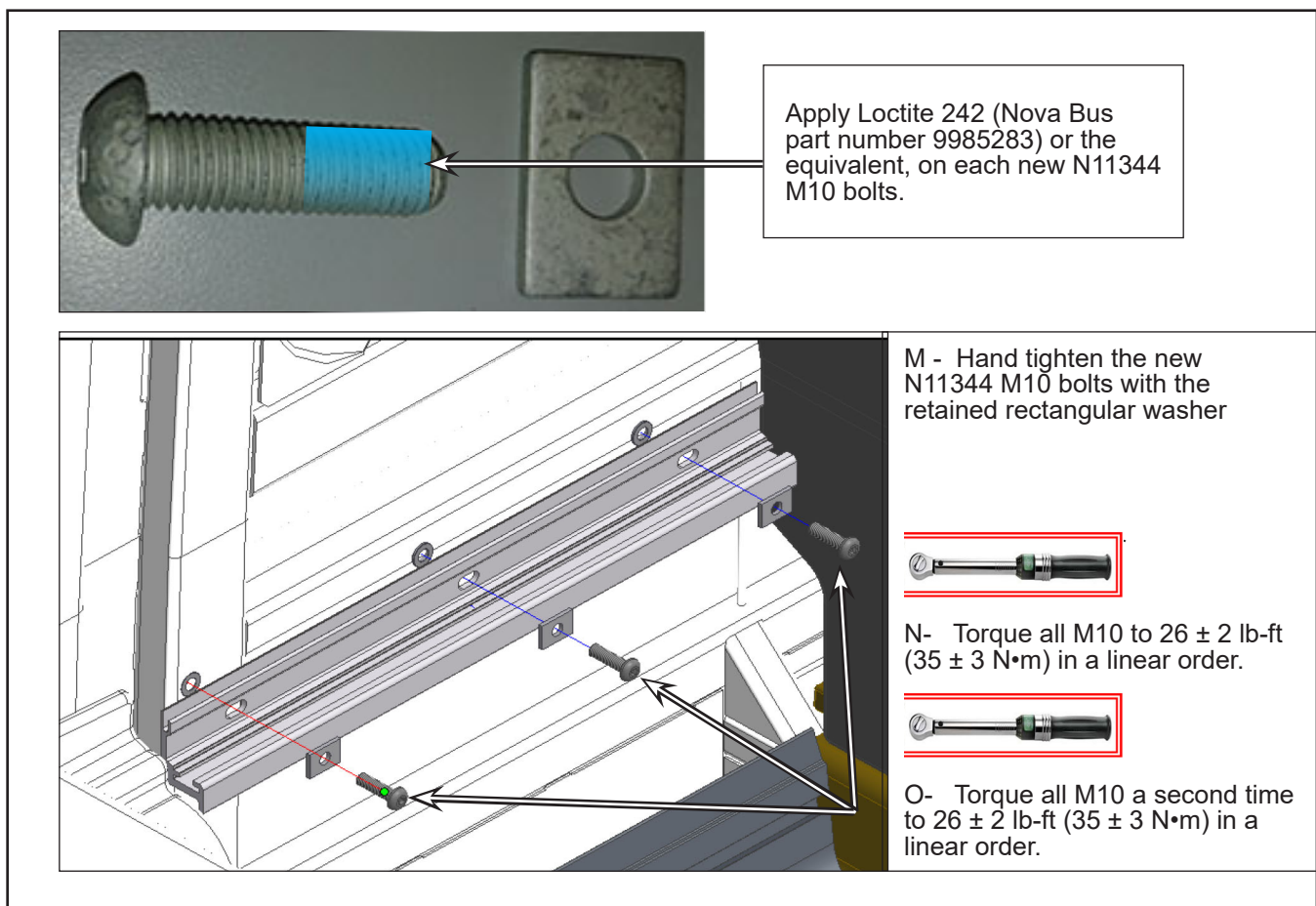

Figure 13 - Preparation and Torque to Apply on New N11344 M10 Bolts

- p. Install the retained rubber filler strips from step G, and with the tape placed on the wall in step 2.1, position them according to the number tag on each strip.
- q. Place L-bracket N8910246-BS on the upper anchor rail and position the middle hole of the L-bracket in line with the tape on the wall. Mark the rubber filler strip on each side of the L-bracket. Repeat this step for all removed cantilever seats with no stanchion affixed to the backrest.
- r. Remove L-bracket N8910246-BS and cut the portion of rubber filler strip that was under the L-bracket. Repeat this operation for all removed seats with no stanchion affixed to the backrest.
- s. Install N44620-02 T-bolts in the upper and lower anchor rail where seats were previously installed. See Figure 14.

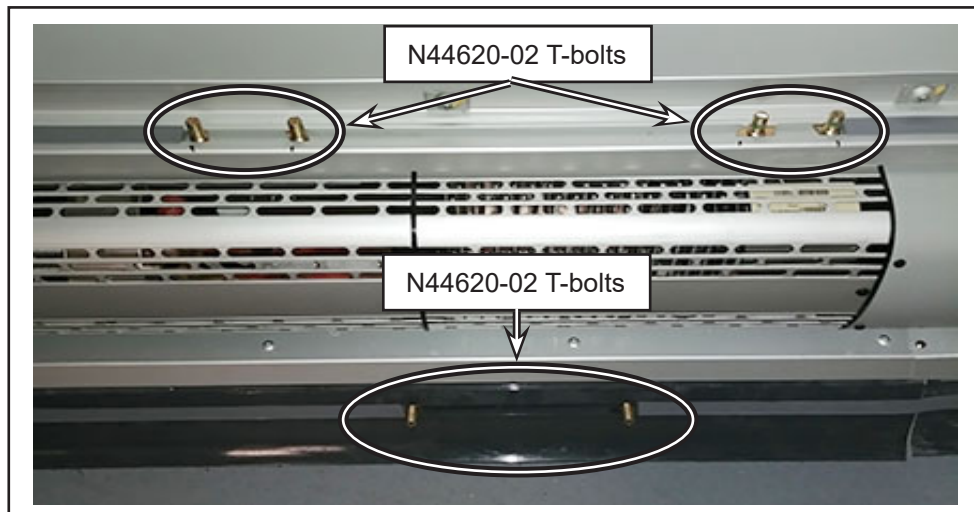

Figure 14 - T-bolts N44620-02

- t. Replace the upper support bracket on all the cantilever-type 2 passenger seats with no stanchion affixed to the backrest according to the procedure detailed in sub step D and E of step 1.2.
- u. Install the retained seats in alignment with the tape placed on the seat anchor rail and wall. See Figure 15.
- v. Affix the seats to the N44620-02 T-bolts with N37109 flanged serrated nuts.
- w. Hand tighten the N37109 flanged nuts on the T-bolts of all the affected seats. Make sure that the puncture in the T-bolts is facing the center of the vehicle. See Figure 15.
- x. With a torque wrench, apply the torque to all the N37109 flange nuts installed. See Figure 15 for torque value.
- y. Apply torque seal to all the torque nuts. See Figure 15.
- z. Install the retained seat belt(s) with new N44620-02 T-bolt and N37109 flanged serrated nuts. Align the seat belt(s) with tape. See Figure 15 for torque value.

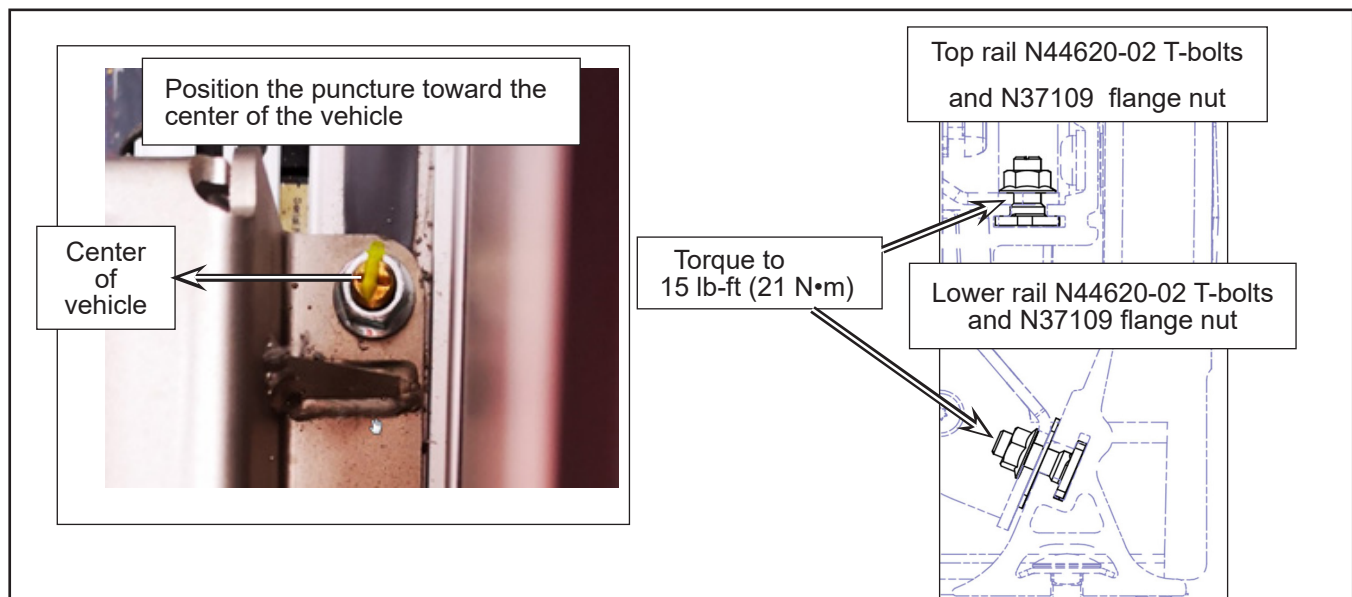
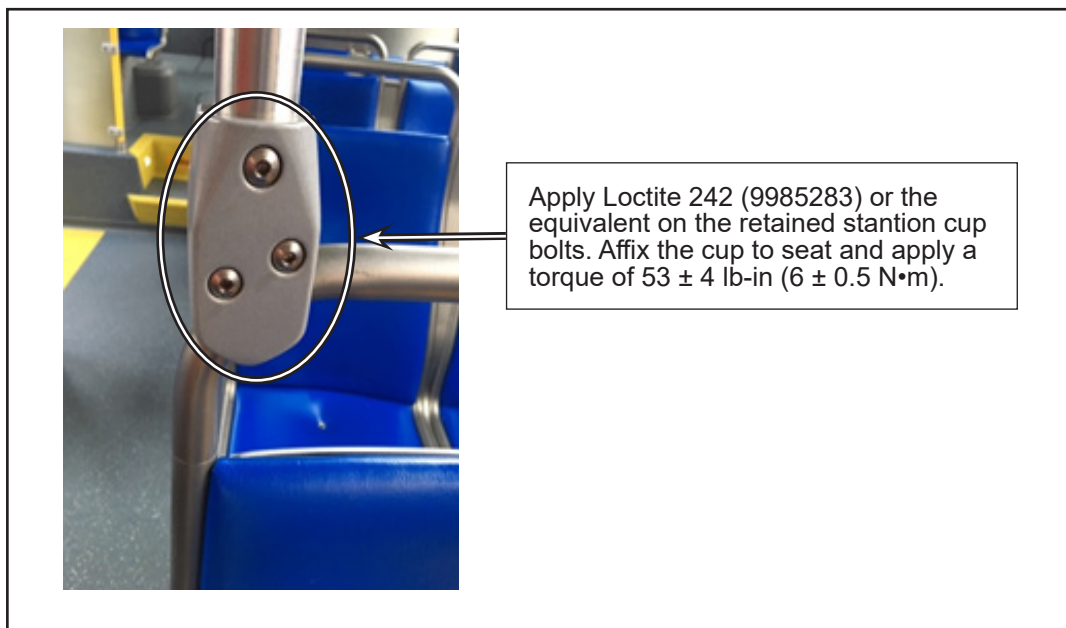

Figure 15 - T-bolts Positioning and Torque Value



- aa. If required, apply Loctite 242 (Nova Bus part number 9985283), or the equivalent to each of the retained stanchion cup bolts.
- ab. Install the retained stanchion cups with the retained hardware. See Figure 16 for torque value.



*Figure 16 - Torque Value for Typical Stanchion Cup Bolts*