

CONDITION OF CONCERN

On certain subject vehicles, the powertrain control module (PCM) software controlling the hydraulic valve clearance adjuster may operate improperly. This occurs when transitioning from cylinder deactivation to full cylinder activation modes while driving, due to inappropriate control logic of the PCM. As a result, an intake valve rocker arm may come out of position and make contact with internal engine parts, which may cause an engine misfire and loss of power and/or Malfunction Indicator Light (MIL) illumination. In the worst case, engine damage may occur, resulting in engine stall while driving without ability to be restarted, which may increase the risk of a crash.

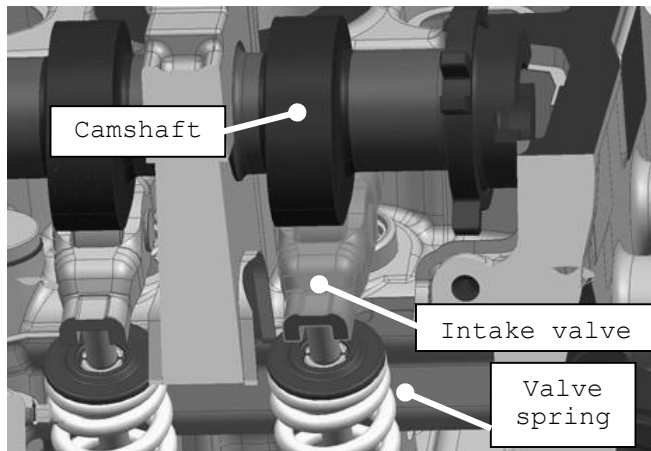

OUTLINE OF REPAIR

Reprogram the PCM with improved hydraulic valve adjustment control software, using M-MDS. The repair must be performed on all subject vehicles. Please refer to the Repair Procedure document on MGSS for further details.

SUBJECT VEHICLES

Model	Subject VIN range	Subject production date range
2018-2019 CX-5	JM3 KF**** J* 300038 - 476254 JM3 KF**** K* 500024 - 622857	From October 3, 2017 through April 23, 2019
2019 Mazda3	built at MC JM1 BP**** K1 100042 - 139973	From September 25, 2018 through May 11, 2019
	built at MMVO 3MZ BP**** KM 100048 - 112251	From January 15, 2019 through May 1, 2019
2018-2019 Mazda6	JM1 GL**** J1 300026 - 336737 JM1 GL**** K1 500004 - 505526	From January 15, 2018 through April 22, 2019

The asterisk symbol "*" can be any letter or number.

OWNER NOTIFICATION

Mazda will notify U.S. owners by first class mail no later than August 25, 2019.

PARTS INFORMATION

Description	Part number	Quantity	Notes
Campaign Label	9999-95-065A-06	1=50 labels	Obtain in Mazda e-Store (no charge)
Vehicle Emission Recall Proof of Correction Certificate *	9999-95-ERPC-99	1=50 certificates	



* California Department of Motor Vehicles and the Commonwealth of Massachusetts, in conjunction with the California Air Resources Board and the Environmental Protection Agency for the State of Massachusetts, have implemented the Registration Renewal/Recall Tie-In Program, which requires the completion of Emission Recalls prior to registration renewal. Mazda dealers must provide customers a **Vehicle Emission Recall - Proof of Correction Certificate** (p/n 9999-95-ERPC-99) upon completion of the recall.

WARRANTY CLAIM PROCESSING INFORMATION

	PCM Reprogramming
Process Number	AK038A
Symptom Code	99
Damage Code	99
Causal Part No.	7777-SP-R50
Quantity	0
Labor Operation	XXR8BFXFX
Labor Hours	0.3 hrs.

RENTAL CAR INFORMATION

Mazda recommends the usage of the MCVP loaner vehicle when available. If all MCVP loaner vehicles are in use and unavailable, and the customer needs a rental car, then use your local rental facility and offer a rental car. Be sure that every effort is made to repair the car within one business day or less in order to allow the next customer the same experience.

Rental Car Warranty Claim Information

	MCVP Vehicle Preferred	Rental Agency Vehicle
Warranty Type Code	N/A MCVP does not require claim submission	A
Symptom Code		99
Damage Code		99
Part Number Main		5555-37-19FR
Part Quantity		0
Labor Operation Code		MM024XRX
Labor Hours		0
Sublet - Rental Car		
Sublet Invoice Number		Number from Rental Invoice or Dealer Purchase Order
Sublet Type Code		Enter "Z9" (other)
Sublet Amount		Up to \$30.00 per day for the number of days customer
Sublet Text		Number of days rental car was supplied to customer

Rental expenses exceeding the two-day limit will require prior Warranty Department Authorization, as outlined in the Mazda Rental Car Reimbursement Program policy.