

May 24, 2019

Version 3

Safety Recall: 2018-19 Odyssey Check Park Mechanism, Battery Terminal Inspection, and Update TCM

Supersedes 19-046, dated May 1, 2019, to revise the information highlighted in **yellow**

AFFECTED VEHICLES

Year	Model	Trim	VIN Range
2018-19	Odyssey	Touring, Elite	Check the iN VIN status for eligibility.

REVISION SUMMARY

- Under SOFTWARE INFORMATION, added a notice.
- Under TCM UPDATE, added a notice.
- Under PARK INSPECTION PROCEDURE, added additional information.

BACKGROUND

A momentary voltage loss to the TCM, usually caused by a loose battery terminal, can cause the transmission to shift to Park while driving. When this happens, the parking mechanism could get damaged, and the vehicle may move while the shifter is in Park.

CUSTOMER NOTIFICATION

Owners of affected vehicles will be sent a notification of this campaign.

Do an iN VIN status inquiry to make sure the vehicle is shown as eligible.

Some vehicles affected by this campaign may be in your new or used vehicle inventory.

Failure to repair a vehicle subject to a recall or campaign may subject your dealership to claims or lawsuits from the customer or anyone else harmed as a result of such failure. To see if a vehicle in inventory is affected by this safety recall, do a VIN status inquiry before selling it.

CUSTOMER INFORMATION:The information in this bulletin is intended for use only by skilled technicians who have the proper tools, equipment, and training to correctly and safely maintain your vehicle. These procedures should not be attempted by "do-it-yourselfers," and you should not assume this bulletin applies to your vehicle, or that your vehicle has the condition described. To determine whether this information applies, contact an authorized Honda automobile dealer.

CORRECTIVE ACTION

- Inspect the transmission's ability to stay in Park (requires an assistant and snapshot upload).
- Replace the transmission if the park inspection procedure fails.
- Inspect the battery terminals.
- Clean or replace the terminals and/or battery if the terminal inspection fails (an extremely small percentage of vehicles may require a new battery or battery terminals).
- Update the TCM (not required if transmission is replaced).

NOTE

If an error occurs during the update, go to TCM UPDATE ERROR.

PARTS INFORMATION (REPAIR PROCEDURE A)

Part Name	Part Number	Quantity
Battery Plus Terminal (large)	32413-TG7-A02	1
Battery Sensor Assembly (negative terminal)	38920-TZ5-A02	1
(L3) Johnson MSDS Battery Assembly	31500-TZ7-AGM100M	1

PARTS INFORMATION (REPAIR PROCEDURE B)

Part Name	Part Number	Quantity
Reman A/T Kit (2019 models)	06200-5MX-A83RM	1
Reman A/T Kit (2018 models)	06200-5MX-A77RM	1
Flange Bolt (12 x 120)	90051-5J4-000	1
Flange Bolt (12 x 45)	90165-SDA-A00	2
Flange Bolt (12 x 85)	95701-12085-07	1
Flange Nut (12 mm)	90371-SAA-010	4
Flange Bolt (10 x 35)	90163-SDA-A01	2
Flange Bolt (10 x 103)	90163-SJH-000	1
Flange Bolt (10 x 25)	90167-SAA-010	4
Self-Lock Nut (10 mm)	90212-SA5-003	9
Pre Chamber Gasket	18393-SDB-A00	1
Exhaust Pipe Gasket (NOK)	18212-SA7-003	2
Split Pin (3.0 x 22)	94201-30220	2
Castle Nut (14 mm)	90365-STX-A00	2
Flange Bolt (12 x 30)	90161-SHJ-A00	8
Flange Bolt (14 x 140)	90165-TZ5-A10	2

Part Name	Part Number	Quantity
Flange Bolt (14 x 125)	90165-TK8-A00	2
Spindle Nut	90305-S3V-A11	2
Snap Ring (32 x 2.2)	44319-STX-A01	2
Flange Bolt (10 x 30)	90163-SDB-A00	3

NOTE

An extremely small percentage of vehicles may require a new battery or battery terminals.

Part Name	Part Number	Quantity
Battery Plus Terminal (large)	32413-TG7-A02	1
Battery Sensor Assembly (negative terminal)	38920-TZ5-A02	1
(L3) Johnson MSDS Battery Assembly	31500-TZ7-AGM100M	1

REQUIRED MATERIALS

Part Name	Part Number	Quantity
Antifreeze/Coolant Type 2	OL999-9011	2

TOOL INFORMATION

NOTE

The following tools are available through the Tool and Equipment Program.

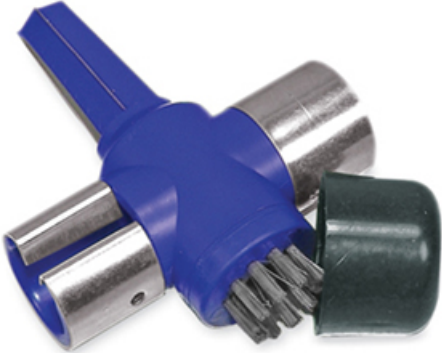
Part Name	Part Number	Quantity
Torque Wrench - A 1/4" torque wrench with a range of 35-53 in/lb.	Model 1501MRH Model 1501MRPH or any commercially available 1/4" with range of 35-53 in/lb	1
Battery Terminal Cleaner 	BTC7B	1

Part Name	Part Number	Quantity
Engine Balance Bar	VSB02C000041	1
Engine Hanger	AAR-T1256	2
Subframe Adaptor	VSB02C000016	1

WARRANTY CLAIM INFORMATION

REPAIR PROCEDURE A

Operation Number	Description	Flat Rate Time	Defect Code	Symptom Code	Template ID	Failed Part Number
7105B6	Do the park inspection procedure (includes time for assistant). Inspect the battery terminals, and check torque. Update the TCM.	0.8 hr	6AN00	Z4J00	A19046A	28102-5MX-A610
7105B7	Do the park inspection procedure (includes time for assistant). Repair one terminal. Update the TCM.	0.9 hr	6AN00	Z4J00	A19046B	28102-5MX-A610
7105B7	Do the park inspection procedure (includes time for assistant). Replace positive terminal. Update the TCM.	0.9 hr	6AN00	Z4J00	A19046C	28102-5MX-A610
7105B7	Do the park inspection procedure (includes time for assistant). Replace negative terminal. Update the TCM.	0.9 hr	6AN00	Z4J00	A29046A	28102-5MX-A610
7105B8	Do the park inspection procedure (includes time for assistant). Repair both terminals. Update the TCM.	1.1 hr	6AN00	Z4J00	A19046D	28102-5MX-A610
7105B8	Do the park inspection procedure (includes time for assistant). Replace both terminals. Update the TCM.	1.1 hr	6AN00	Z4J00	A19046E	28102-5MX-A610

Operation Number	Description	Flat Rate Time	Defect Code	Symptom Code	Template ID	Failed Part Number
7105B9	Do the park inspection procedure (includes time for assistant). Install new battery (Includes internal resistance reset). Update the TCM.	1.6 hr	6AN00	Z4J00	A19046F	28102-5MX-A610

REPAIR PROCEDURE B

Operation Number	Description	Flat Rate Time	Defect Code	Symptom Code	Template ID	Failed Part Number
2185E0	2018 Odyssey -Do the park inspection procedure (includes time for assistant). Replace the transmission (includes alignment and neutral position memorization). Inspect battery terminals, and check torque.	7.5 hr	6AN00	Z4J00	A19046G	28102-5MX-A610
2185E0	2019 Odyssey -Do the park inspection procedure (includes time for assistant). Replace the transmission (includes alignment and neutral position memorization). Inspect battery terminals, and check torque.	7.5 hr	6AN00	Z4J00	A19046H	28102-5MX-A610
2185E1	2018 Odyssey - Do the park inspection procedure (includes time for assistant). Replace the transmission (Includes alignment and neutral position memorization). Repair one terminal.	7.6 hr	6AN00	Z4J00	A19046J	28102-5MX-A610
2185E1	2018 Odyssey - Do the park inspection procedure (includes time for assistant). Replace the transmission (Includes alignment and neutral position memorization). Replace positive terminal.	7.6 hr	6AN00	Z4J00	A19046K	28102-5MX-A610

Operation Number	Description	Flat Rate Time	Defect Code	Symptom Code	Template ID	Failed Part Number
2185E1	2018 Odyssey - Do the park inspection procedure (includes time for assistant). Replace the transmission (Includes alignment and neutral position memorization). Replace negative terminal.	7.6 hr	6AN00	Z4J00	A29046B	28102-5MX-A610
2185E1	2019 Odyssey - Do the park inspection procedure (includes time for assistant). Replace the transmission (Includes alignment and neutral position memorization). Repair one terminal.	7.6 hr	6AN00	Z4J00	A19046L	28102-5MX-A610
2185E1	2019 Odyssey - Do the park inspection procedure (includes time for assistant). Replace the transmission (Includes alignment and neutral position memorization). Replace positive terminal.	7.6 hr	6AN00	Z4J00	A19046M	28102-5MX-A610
2185E1	2019 Odyssey - Do the park inspection procedure (includes time for assistant). Replace the transmission (Includes alignment and neutral position memorization). Replace negative terminal.	7.6 hr	6AN00	Z4J00	A29046C	28102-5MX-A610
2185E2	2018 Odyssey - Do the park inspection procedure (includes time for assistant). Replace the transmission (Includes alignment and neutral position memorization). Repair both terminals.	8.0 hr	6AN00	Z4J00	A19046N	28102-5MX-A610

Operation Number	Description	Flat Rate Time	Defect Code	Symptom Code	Template ID	Failed Part Number
2185E2	2018 Odyssey - Do the park inspection procedure (includes time for assistant). Replace the transmission (Includes alignment and neutral position memorization). Replace both terminals.	8.0 hr	6AN00	Z4J00	A19046P	28102-5MX-A610
2185E2	2019 Odyssey - Do the park inspection procedure (includes time for assistant). Replace the transmission (Includes alignment and neutral position memorization). Repair both terminals.	8.0 hr	6AN00	Z4J00	A19046Q	28102-5MX-A610
2185E2	2019 Odyssey - Do the park inspection procedure (includes time for assistant). Replace the transmission (Includes alignment and neutral position memorization). Replace both terminals.	8.0 hr	6AN00	Z4J00	A19046R	28102-5MX-A610
2185E3	2018 Odyssey - Do the park inspection procedure (includes time for assistant). Replace the transmission (Includes alignment and neutral position memorization). Repair both terminals, and replace the battery (includes internal resistance reset).	8.5 hr	6AN00	Z4J00	A19046S	28102-5MX-A610

Operation Number	Description	Flat Rate Time	Defect Code	Symptom Code	Template ID	Failed Part Number
2185E3	2018 Odyssey - Do the park inspection procedure (includes time for assistant). Replace the transmission (Includes alignment and neutral position memorization). Replace both terminals, and replace the battery (includes internal resistance reset).	8.5 hr	6AN00	Z4J00	A19046T	28102-5MX-A610
2185E3	2019 Odyssey - Do the park inspection procedure (includes time for assistant). Replace the transmission (Includes alignment and neutral position memorization). Repair both terminals, and replace the battery (includes internal resistance reset).	8.5 hr	6AN00	Z4J00	A19046U	28102-5MX-A610
2185E3	2019 Odyssey - Do the park inspection procedure (includes time for assistant). Replace the transmission (Includes alignment and neutral position memorization). Replace both terminals, and replace the battery (includes internal resistance reset).	8.5 hr	6AN00	Z4J00	A19046V	28102-5MX-A610

Skill Level: Repair Technician

SOFTWARE INFORMATION

NOTE

Unnecessary or incorrect repairs resulting from a failure to update the i-HDS are not covered under warranty.

i-HDS Software Version: **1.004.064 or later**

J2534 Software Information: **1.00.0020**

- PC Application Version **1.1.0.6 or later**
- Database update **06-APR-2019 or later**

Before beginning the repair, make sure that both the i-HDS and J2534 software are updated as listed above.

Do only the update listed in this service bulletin.

You cannot apply the updates with the MVCI as a standalone tool. To update the software you must use the MVCI or the DST-i interface in conjunction with the J2534 Rewrite PC application on the i-HDS.

For more information about updating the i-HDS, the MVCI, and vehicle systems, refer to Service Bulletin 01-023, *Updating Control Units/Modules*.

Connect the i-HDS, and go to **AT Data List**. Check to see if the software has been updated by comparing the program P/N against the table below.

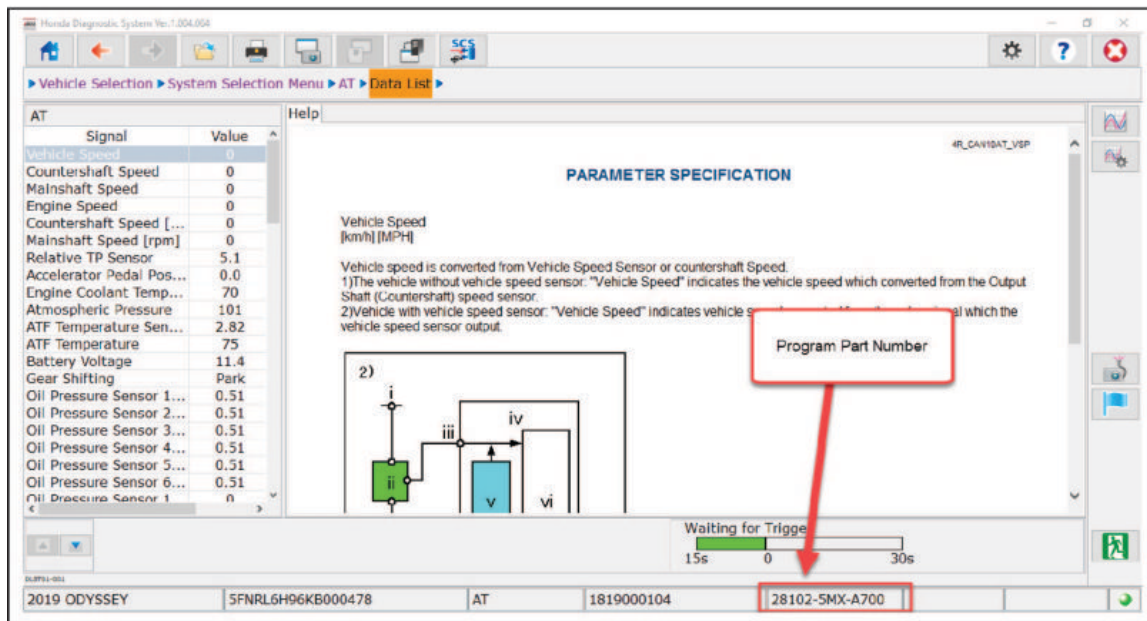

- **2018 models:** If the program P/N currently in the **AT Data List** is not the same or later as in the chart below, the vehicle has not been updated. Go to PARK INSPECTION PROCEDURE.
- **2019 models:** If the program P/N currently in the **AT Data List** reads 28102-5MX-A700 or 28102-5MX-A710, the vehicle has not been updated. Go to PARK INSPECTION PROCEDURE.

Year/Model	Software System	Program ID (or later)	Program P/N (or later)
2018	A/T	MXA610	28102-5MX-A610

Year/Model	Software System	Program ID (or later)	Program P/N (or later)
2019	A/T	MXA001	28102-5MX-A001

NOTICE

- Connect a fully charged jump box to the battery before updating the TCM. Failure to do so may damage the TCM, requiring transmission replacement.
- To prevent damaging the TCM, do not operate anything electrical (headlights, audio system, brakes, A/C, power windows, door locks, etc.) during the update.

NOTE

If an error occurs during the update, go to TCM UPDATE ERROR.

PARK INSPECTION PROCEDURE

NOTES

- **This step is critical. Make sure the park pawl is properly engaging by rocking the vehicle back and forth.** See example videos.
- You will need an assistant and **a surface with good traction** to reach the amount of g-force needed to do this inspection.
- You need to send three snap shots of the process to Tech Line. If they are not sent, your claim will be debited and you will need to repeat this procedure at your dealership's expense.

NOTE

The blue component is the park pawl; the red component is the park gear.

 **GOOD - Holds in Park**

 **NO GOOD - Does NOT Hold in Park**



Click on the images for example videos.

1. Park on a flat surface with the transmission in Park, the parking brake released, the engine turned off, and ignition turned to ON.

NOTE

Make sure the surface provides good traction. If the wheels slip, you may not be able to get the **0.30 G/ 2.9 m/s²** force to complete the check.

2. Connect the i-HDS, then enter the RO, and select **System Selection Menu**.

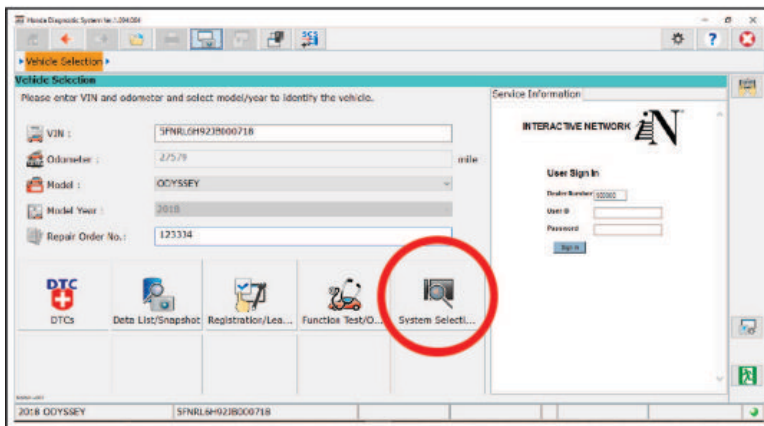

3. Select **ABS/VSA**.

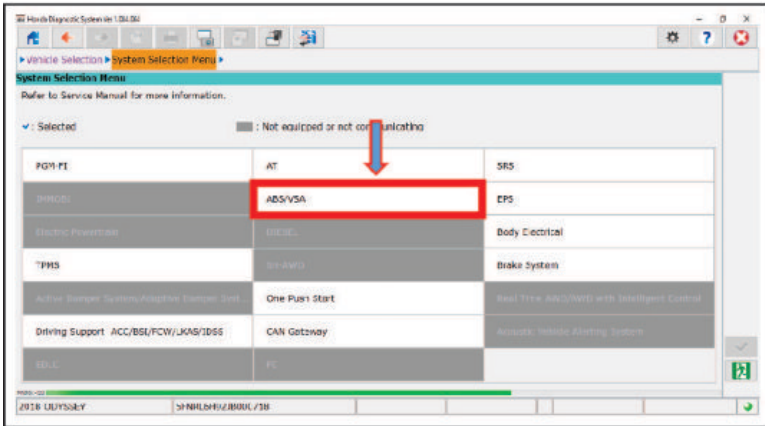

4. Select **Snapshot**.

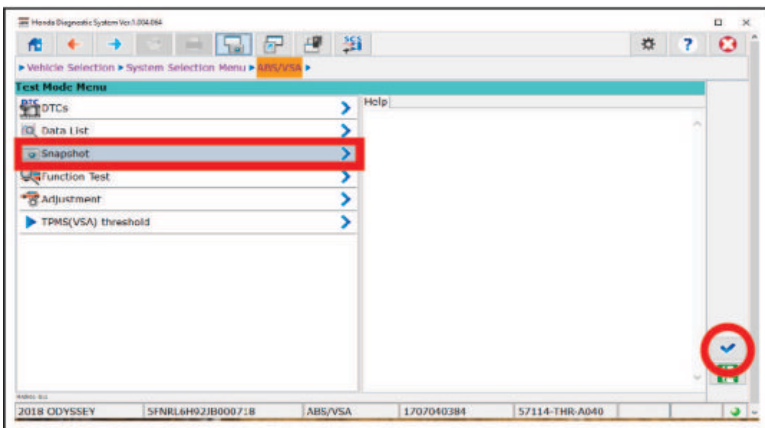

5. Clear all monitor signals from the list.

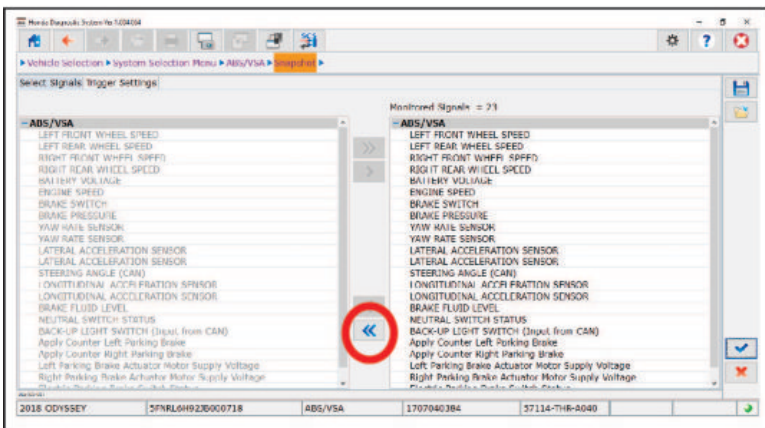

6. Add **LONGITUDINAL ACCELERATION SENSOR** only.

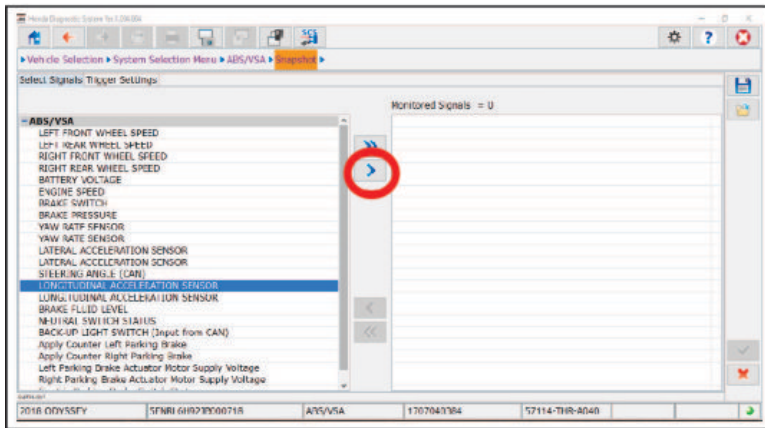

7. Select the check mark.

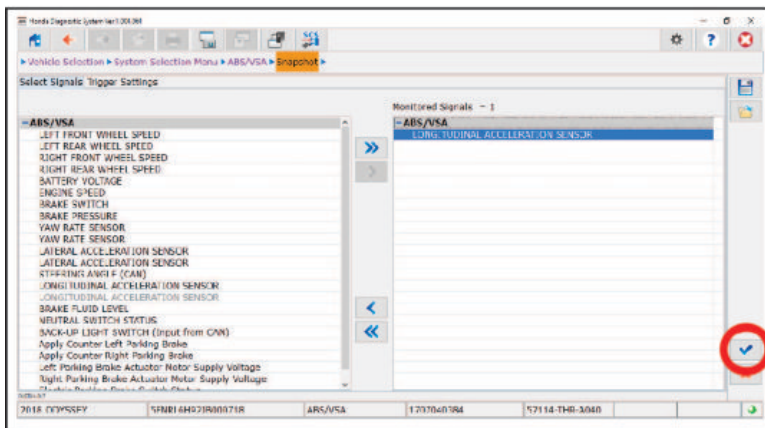

8. Select the line graph.

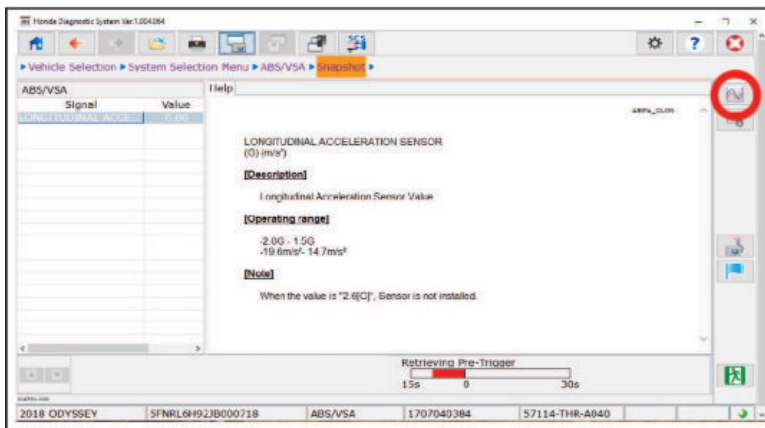

9. Set up the vehicle for snapshots.

- Make sure the surface provides good traction. If the wheels slip, you may not be able to get the **0.30 G/ 2.9 m/s²** force to complete the check. .
- Place commercially available wheel chocks about a foot away from the front and back of one of the rear wheels.



- Close all doors, and open all windows.
- Place a fender cover over the rear doors to protect the paint.
- Do not use the interior grab handle or exterior door handle.
- With help from an assistant, rock the vehicle back and forth by pushing and pulling on the B-pillar with maximum force while monitoring **LONGITUDINAL ACCELERATION SENSOR** in the data list.

NOTE

An assistant and **a surface with good traction** is necessary to obtain the force needed for the inspection.



- Place the i-HDS on the rear seat so you can monitor the screen.

10. Start the snapshot, and rock the vehicle back and forth with maximum force until you get at least five peak counts at or above **0.30 G/2.9 m/s²**. Once you get five counts, stop rocking the vehicle and wait for the snapshot to complete.

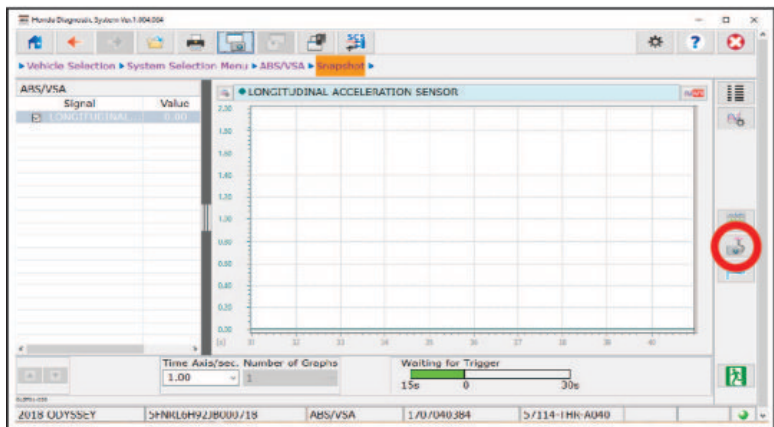

11. Once the snapshot is complete, save it.

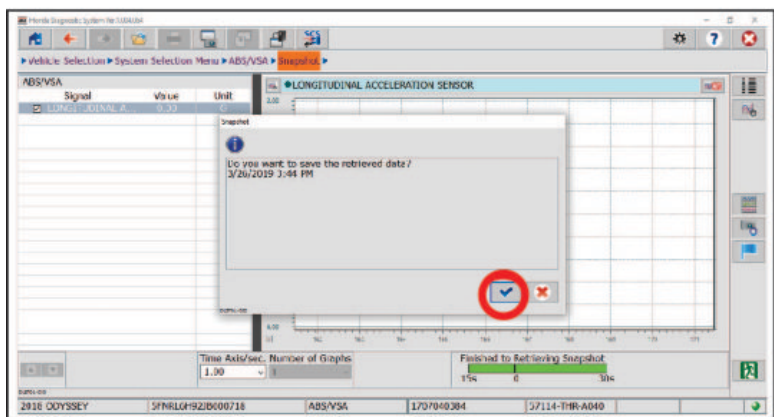

12. Select the open folder to review the snapshot.

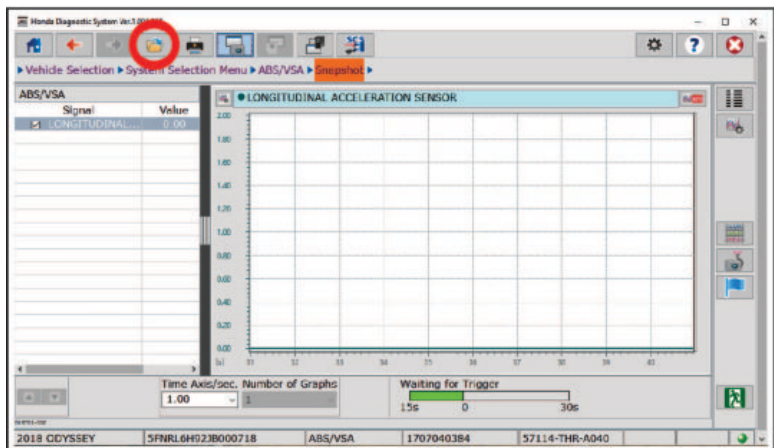

Did the vehicle stay in Park while you got at least five counts above 0.30 G//2.9 m/s²?

NOTE

The parameter display can be changed by selecting the current display unit.

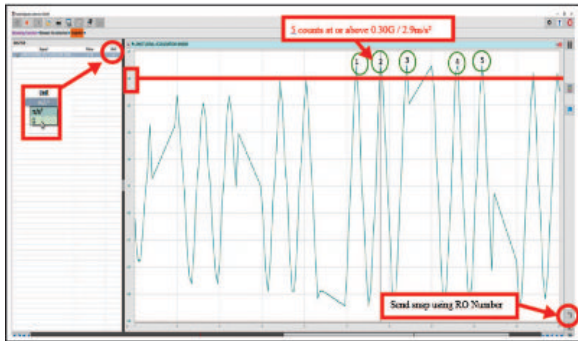

Yes - Send the snapshot to Tech Line using the RO number, then go to step 13. If it stayed in Park but you failed to get at least five peak counts of or above 0.30 G//2.9 m/s², **make sure the vehicle is on a surface with good traction.** Then, repeat steps 10 thru 12.

No - If it did not hold in Park, send the snapshot to Tech Line using the RO number, then go to REPAIR PROCEDURE B.

- 13. Remove the wheel chock, shift to Drive, move the vehicle about 1 foot, then shift back to Park.
- 14. Repeat steps 9 thru 13 two more times.

NOTE

Make sure you send all three snapshots to Tech Line using the RO number. You will not need to contact Tech Line, but claims with no snapshots are subject to debit.

- 15. Did the vehicle hold in park while you got at least five counts above 0.30 G//2.9 m/s² in all three of the park inspection procedures?

Yes - Go to REPAIR PROCEDURE A.

No - Go to REPAIR PROCEDURE B.

REPAIR PROCEDURE A

NOTICE

- Battery terminal installation on this vehicle is critical. Failure to follow the terminal installation, or inspection procedures could cause electrical problems, stalling, and/or DTCs to set. Do not over torque the terminals, and do not use an impact gun.
 - Battery terminal installation must be level or below the post. See GOOD and NO GOOD example pictures.
1. Remove the front bulkhead cover.

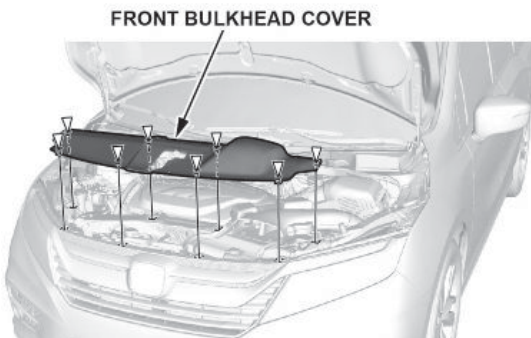

2. Remove the air intake duct.

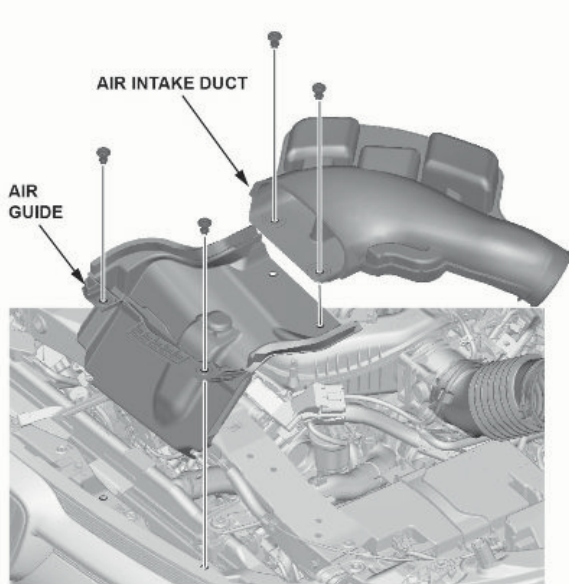

3. Compare both battery terminals to the examples below.

 GOOD



 NO GOOD



Do the battery terminals look like the good example?

Yes - Go to step 4.

No - Go to TERMINAL REPAIR.

4. While holding down the terminal, torque both positive and negative clamps to **4-6 N•m (35-53 lb-in)**

NOTE

Do not over torque the terminal.

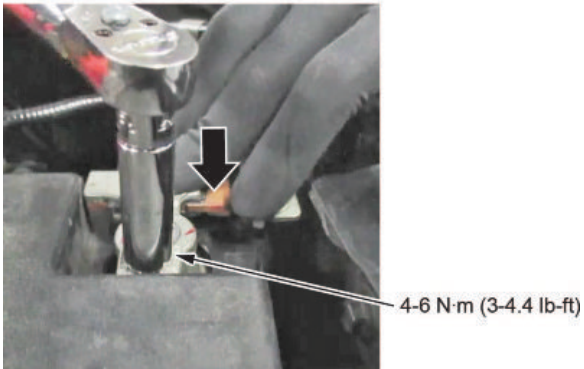

5. Make sure the connection is tight by wiggling the terminals back and forth.

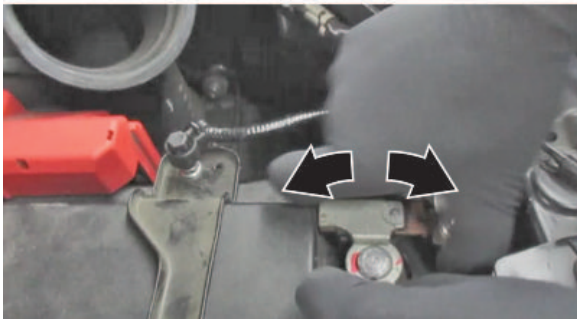

Are both terminals secure?

Yes - Apply multipurpose grease to the terminals to prevent corrosion, and install the air intake duct and the bulkhead cover. Then, go to TCM UPDATE.

No - Go to TERMINAL REPAIR.

TERMINAL REPAIR

1. Remove the terminal or terminals and clean the post using an approved battery terminal cleaner.

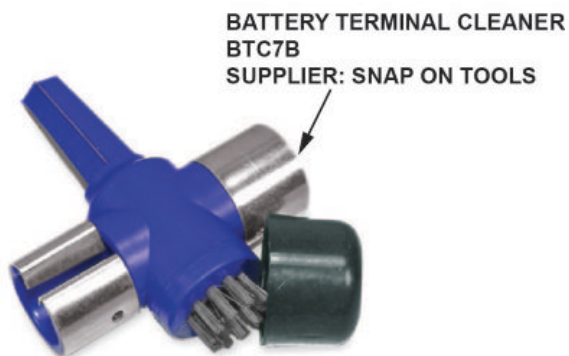

- 1.1. Make sure the ignition is turned to OFF.

1.2. Disconnect and isolate the negative cable with the battery sensor from the battery.

NOTES

- Always disconnect the negative side first.
- To prevent damage to the connector, do not hold it when removing the battery terminal.
- Do not disconnect the battery sensor from the cable.

1.3. Open the terminal cover.

1.4. Disconnect the terminal from the battery and clean them.

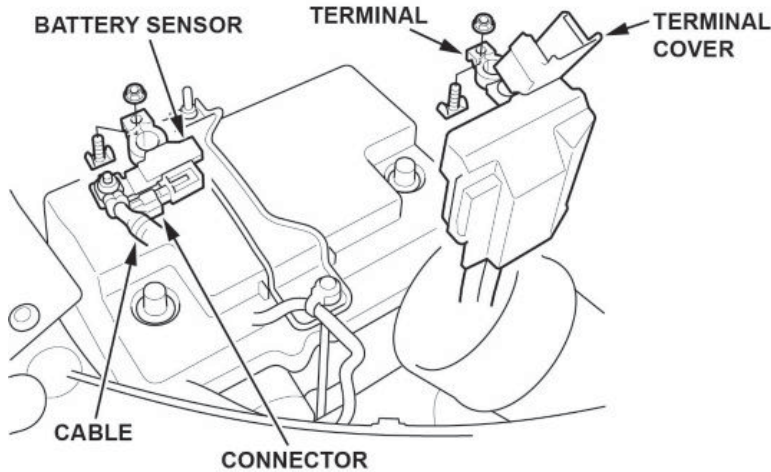

2. While holding down the terminal, torque both positive and negative clamps to **4-6 N•m (35-53 lb-in)**.

NOTES

- Do not over torque the terminal.
- Always connect the positive side first.

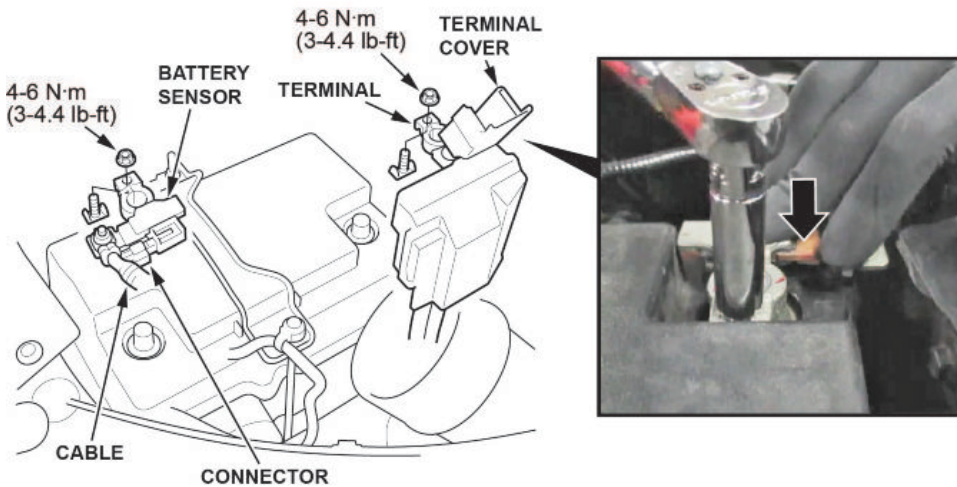

3. Compare both of the battery terminals to the examples below.

 **GOOD**



 **NO GOOD**



Do the battery terminals look like the good example?

Yes - Go to step 4.

No - Go to REPLACE BATTERY TERMINAL.

4. Make sure the connection is tight by wiggling the terminals back and forth.

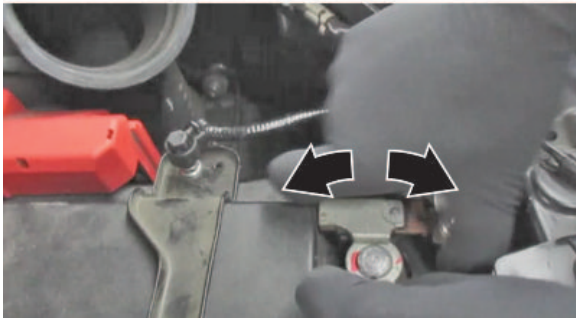

Are both terminals secure?

Yes - Apply multipurpose grease to the terminals to prevent corrosion, and install the air intake duct and the bulkhead cover. Then, go to TCM UPDATE

No - Go to REPLACE BATTERY TERMINAL.

REPLACE BATTERY TERMINAL

1. Remove the battery terminal that does not sit at or below the top of the post.
2. Install a new terminal, and torque the clamp nut to **4-6 N•m (35-53 lb-in)** while holding it down.

NOTES

- Always disconnect the negative side first.
- To prevent damage to the connector, do not hold it when removing the battery terminal.
- Do not disconnect the battery sensor from the cable.

3. Compare both of the battery terminals to the examples below.



Do the battery terminals look like the good example?

Yes - Go to step 4.

No - Go to BATTERY REPLACEMENT, BATTERY RESISTANCE RESET PROCEDURE.

4. Make sure the connection is tight by wiggling the terminals back and forth.

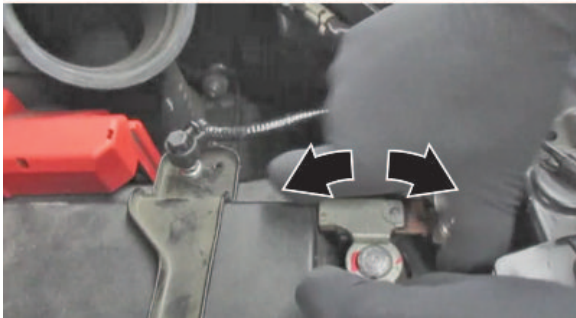

Are both terminals secure?

Yes - Apply multipurpose grease to the terminals to prevent corrosion, and install the air intake duct and the bulkhead cover. Then, go to TCM UPDATE.

No - Go to BATTERY REPLACEMENT, BATTERY RESISTANCE RESET PROCEDURE.

BATTERY REPLACEMENT, BATTERY RESISTANCE RESET PROCEDURE

1. Disconnect the battery terminals.
 - 1.1. Make sure the ignition is turned to OFF.
 - 1.2. Disconnect and isolate the negative cable with the battery sensor from the battery.

NOTES

- Always disconnect the negative side first.
 - To prevent damage to the connector, do not hold it when removing the battery terminal.
 - Do not disconnect the battery sensor from the cable.
- 1.3. Open the terminal cover.

1.4. Disconnect the terminal from the battery.

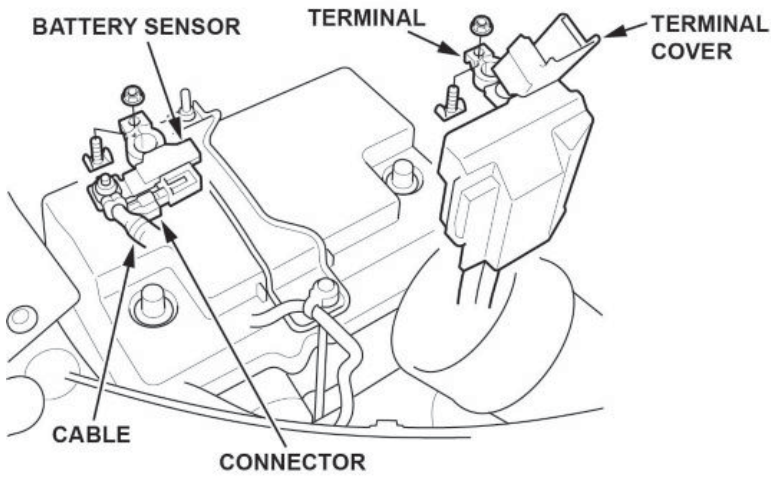

2. Remove the setting plate.
3. Remove the battery cover.
4. Remove the battery.

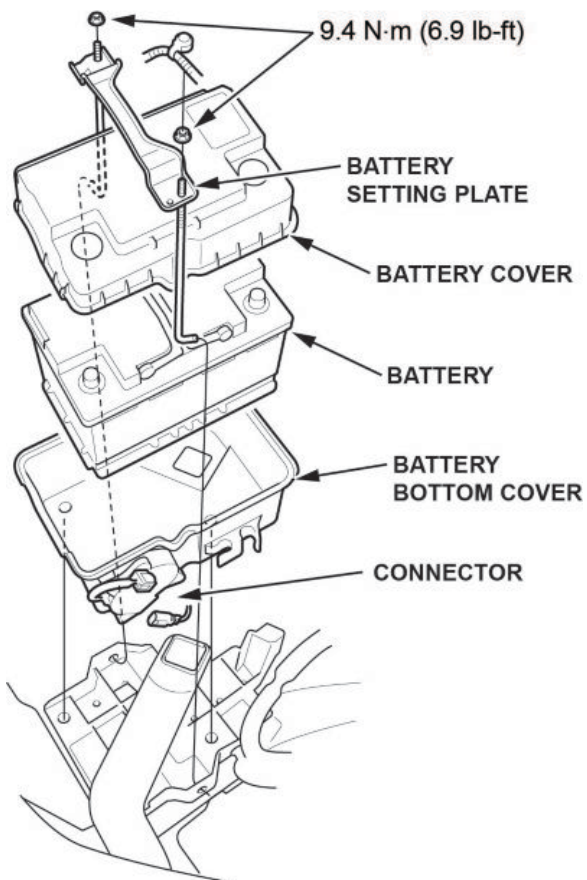

5. Install a new battery. Then reinstall the battery cover, and the setting plate in the reverse order of removal.

6. While holding down the terminal, torque both positive and negative clamps to **4-6 N•m (35-53 lb-in)**.

NOTES

- Do not over torque the terminal.
- Always connect the positive side first.

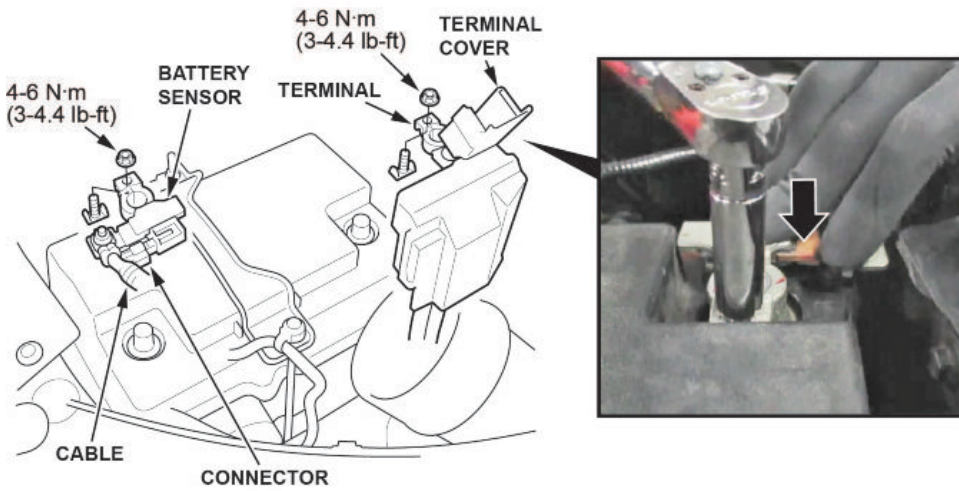

7. Compare both of the battery terminals to the examples below.

 **GOOD**



 **NO GOOD**



Do the battery terminals look like the good example?

Yes - Go to step 8.

No - Remove and reinstall the terminals, then go to step 7.

8. Make sure the connection is tight by wiggling the terminals back and forth.

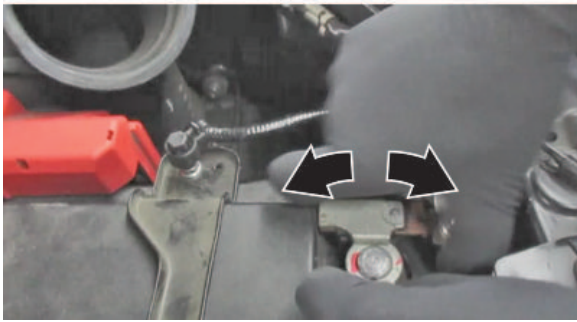

Are both terminals secure?

Yes - Apply multipurpose grease to the terminals to prevent corrosion. Then, go to BATTERY INTERNAL RESISTANCE RESET.

No - Remove and reinstall the terminals, and go to step 7.

BATTERY INTERNAL RESISTANCE RESET

NOTE

Do this procedure only if the battery was replaced.

1. Make sure all electrical systems (A/C, audio, lights, etc) are turned off.
2. Turn the ignition to OFF.
3. Turn the ignition to ACCESSORY.
4. Turn the ignition to ON.
5. Start the engine, and let it idle for **1 minute** or more.
6. Turn the ignition to OFF.
7. Repeat steps 3 thru 6 at least four times.

NOTE

The internal resistance of the battery may not be updated if the engine starts up immediately from the OFF position. It has to go through the ACCESSORY and ON position.

8. Turn the ignition to ON.
9. Connect the i-HDS and select **PGM-FI**.
10. Check **IDLE STOP INHIBIT (BATTERY DETERIORATION)** in the **Data List**.
Normal - The battery internal resistance test is complete.
INHIBITED - Replace the battery, then do this battery internal resistance reset procedure again.
11. Turn the ignition to OFF, and disconnect the i-HDS.
12. Install the air intake duct and bulkhead cover.
13. Go to TCM UPDATE.

TCM UPDATE

NOTE

Unnecessary or incorrect repairs resulting from a failure to update the i-HDS are not covered under warranty.

i-HDS Software Version: **1.004.064 or later**

J2534 Rewrite Software Information: **1.00.0020**

- PC Application Version **1.1.0.6 or later**
- Database update **06-APR-2019 or later**

Before beginning the repair, make sure that both the i-HDS and J2534 Rewrite software are updated as listed above.

Do only the update listed in this service bulletin.

You cannot apply the updates with the MVCI as a standalone tool. To update the software you must use the MVCI or the DST-i interface in conjunction with the J2534 Rewrite PC application on the i-HDS.

For more information about updating the i-HDS, the MVCI, and vehicle systems, refer to service bulletin 01-023, *Updating Control Units/Modules*.

Connect the i-HDS, and go to **AT Data List**. Check to see if the software has been updated by comparing the program P/N against the table below.

- **2018 models:** If the program P/N currently in the **AT Data List** is not the same or later as in the chart below, the vehicle has not been updated. Update the TCM.
- **2019 models:** If the program P/N currently in the **AT Data List** reads 28102-5MX-A700 or 28102-5MX-A710, the vehicle has not been updated. Update the TCM.

Year/Model	Software System	Program ID (or later)	Program P/N (or later)
2018	A/T	MXA610	28102-5MX-A610
2019	A/T	MXA710	28102-5MX-A001

NOTICE

- **Connect a fully charged jump box on the battery before updating the TCM. Failure to do so may damage the TCM, requiring transmission replacement.**
- **To prevent damaging the TCM, do not operate anything electrical (headlights, audio system, brakes, A/C, power windows, door locks, etc.) during the update.**

Update the TCM software using the i-HDS J2534 rewrite software with the MVCI or DST-i. Refer to Service Bulletin 01-023, *Updating Control Units/Modules*.

NOTE

If an error occurs during the update, go to TCM UPDATE ERROR.

TCM UPDATE ERROR

NOTICE

- Do not disconnect the battery or turn the ignition completely to OFF (IGN 0). You may damage the TCM.
- When this error occurs, the MID information may be confusing. Pressing the ENGINE START/STOP button twice will turn the ignition to ACCESSORY, and holding it will turn the ignition to OFF. Do not press and hold the ENGINE START/STOP button, or turn the ignition to OFF during the update.

If there is an interruption during the update process, you will get the following messages on the i-HDS and MID.

Cycle the ignition twice; this will turn the ignition to ACCESSORY. Then cycle the ignition one more time to turn it to ON.

Then, restart the update.

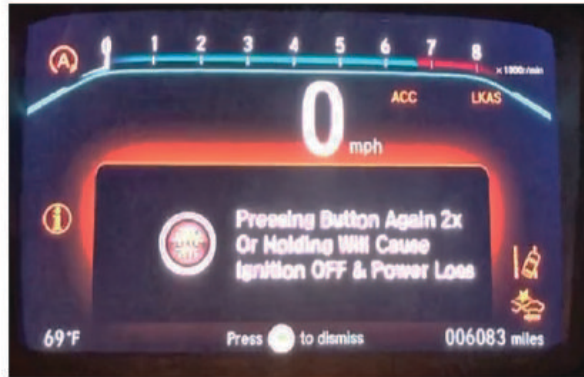
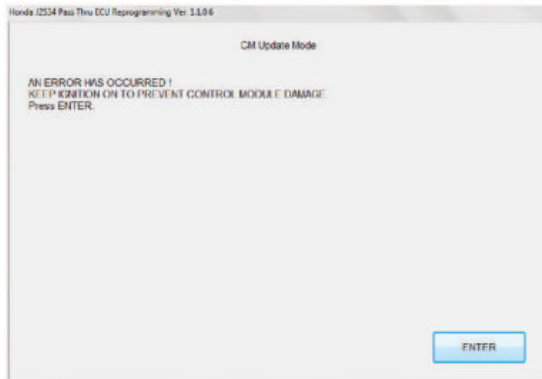

REPAIR PROCEDURE B

NOTE

Do not drain the ATF from the old transmission. The replacement (reman) transmission comes pre-filled with ATF.

1. Remove the engine cover.

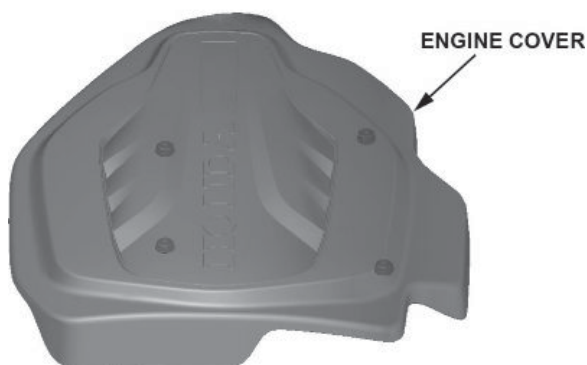

2. Remove the bulkhead cover.

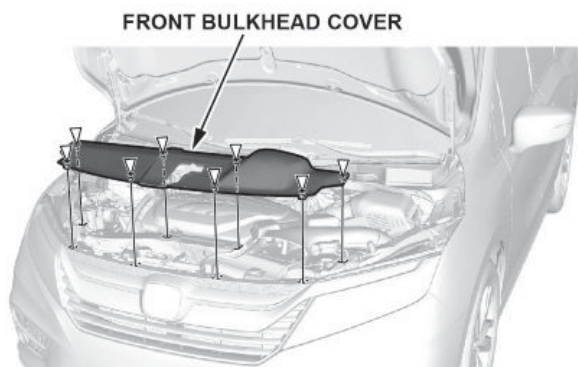

3. Remove the air intake duct.

4. Remove the air guide.

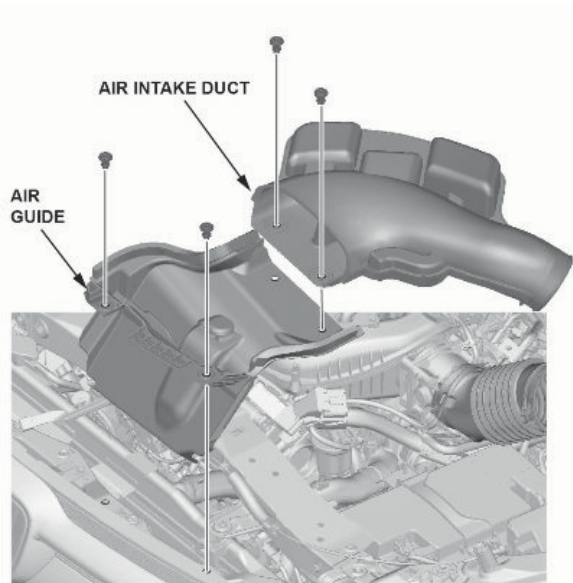

5. Disconnect the battery terminals.

5.1. Make sure the ignition is turned to OFF.

5.2. Disconnect and isolate the negative cable with the battery sensor from the battery.

NOTES

- Always disconnect the negative side first.
- To prevent damage to the connector, do not hold it when removing the battery terminal.
- Do not disconnect the battery sensor from the cable.

5.3. Open the terminal cover.

5.4. Disconnect the terminal from the battery.

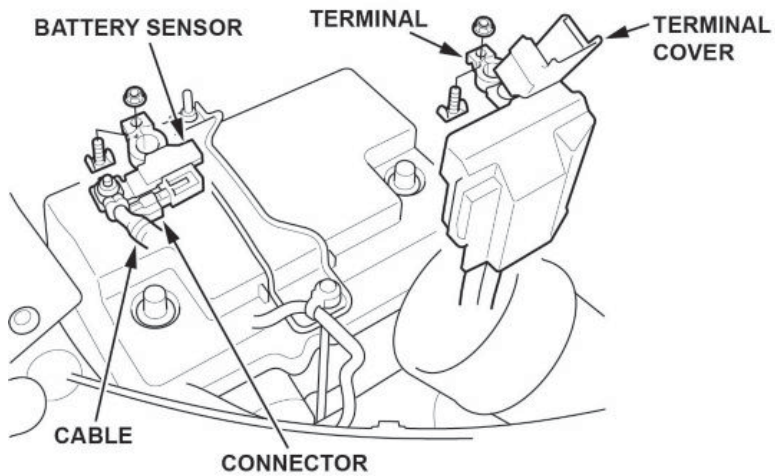

6. Remove the setting plate.
7. Remove the battery cover.
8. Remove the battery.
9. Remove the battery bottom cover.
10. Disconnect the battery fan motor connector.

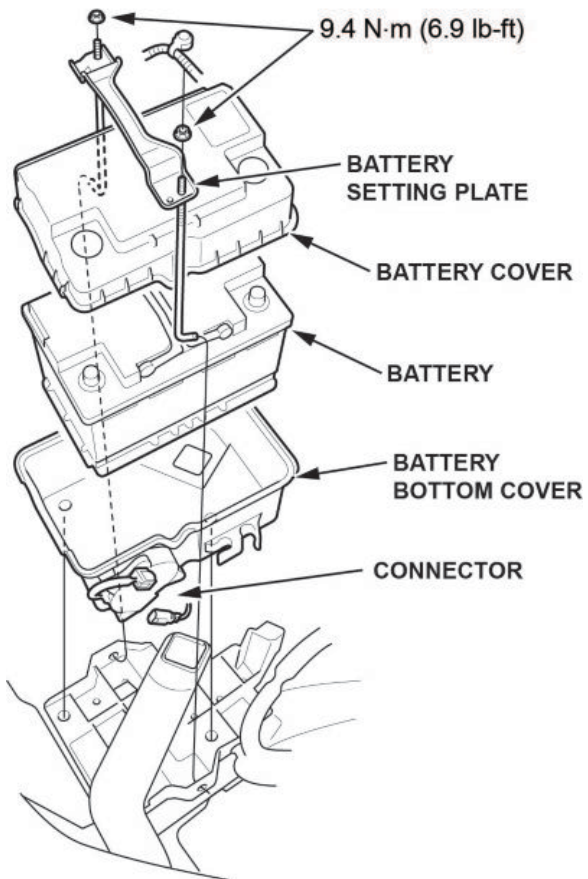

11. Move the intake air duct.
12. Remove the air cleaner.

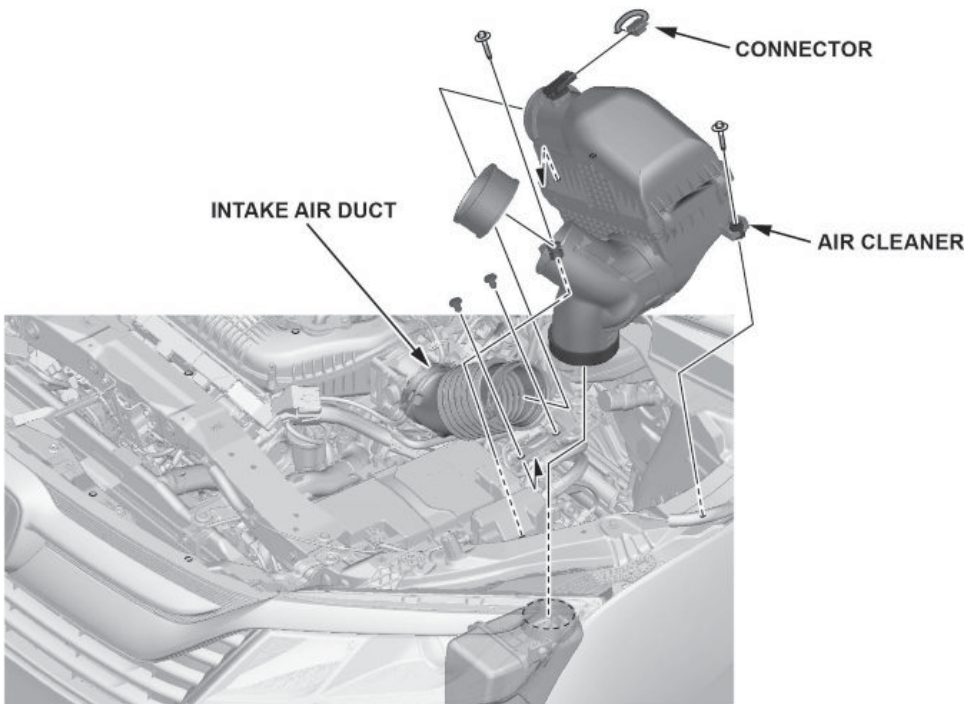

13. Remove the skid block.
14. Disconnect the positive cable from the starter.
15. Remove the starter and connector.

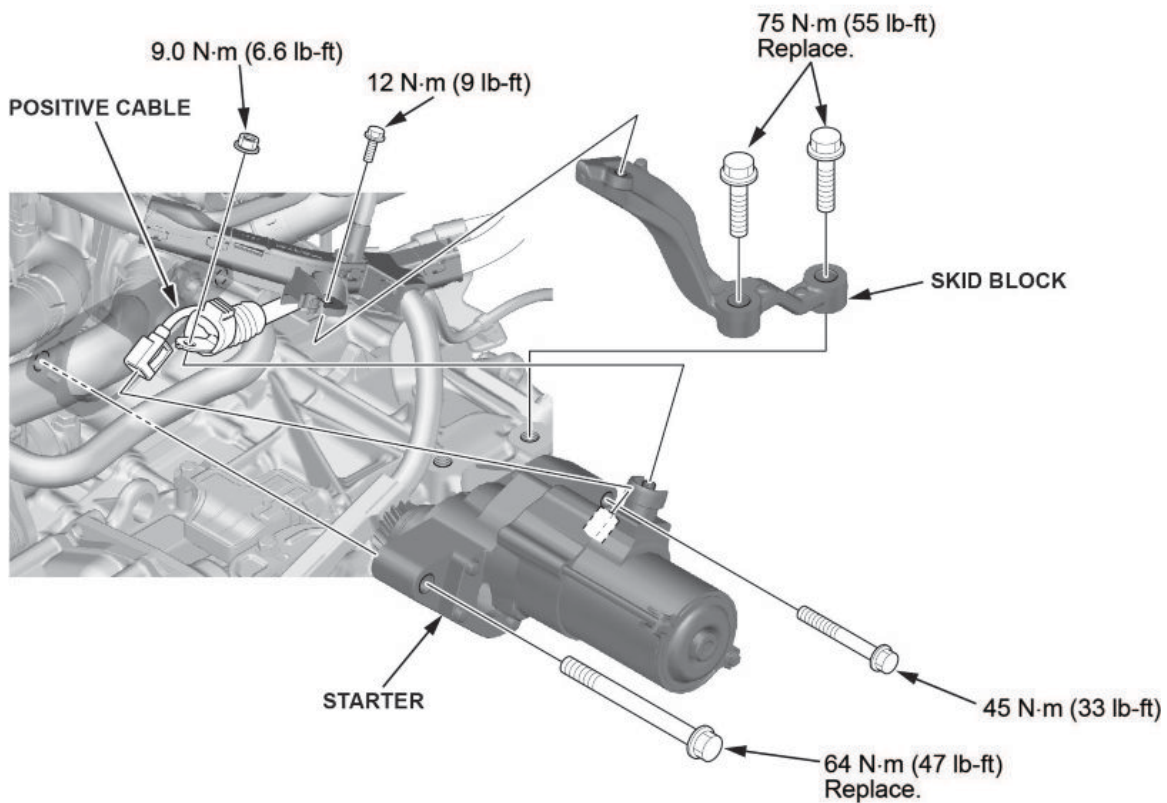

16. Remove the battery base.
17. Disconnect the breather tube.
18. Disconnect the TCM connector.
19. Remove the upper transmission mounting bolt.
20. Disconnect the speed sensor.
21. Remove the heater hose bracket.
22. Remove the harness bracket bolts.

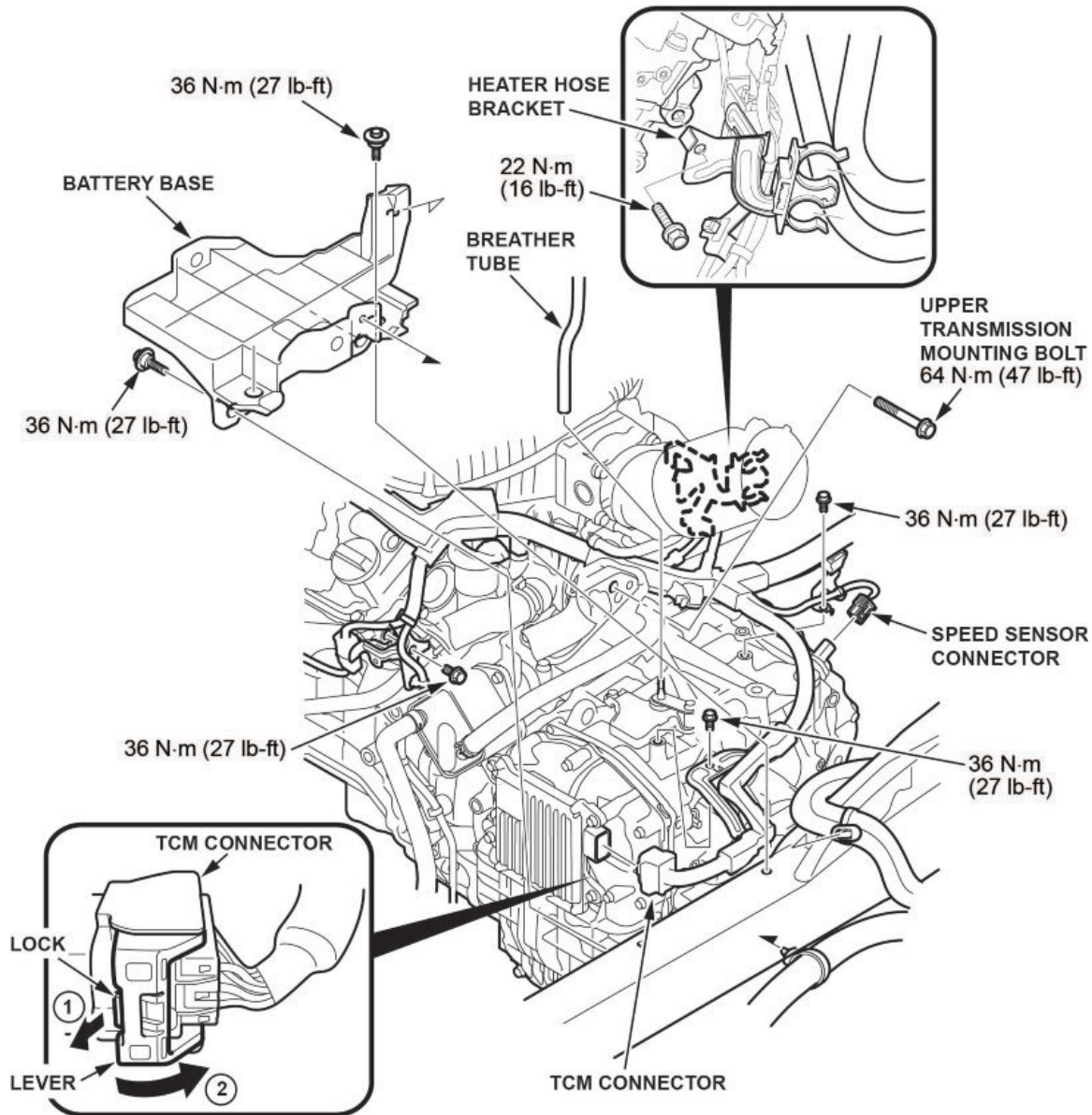

23. Raise the vehicle on a lift.

24. Remove the splash shield.

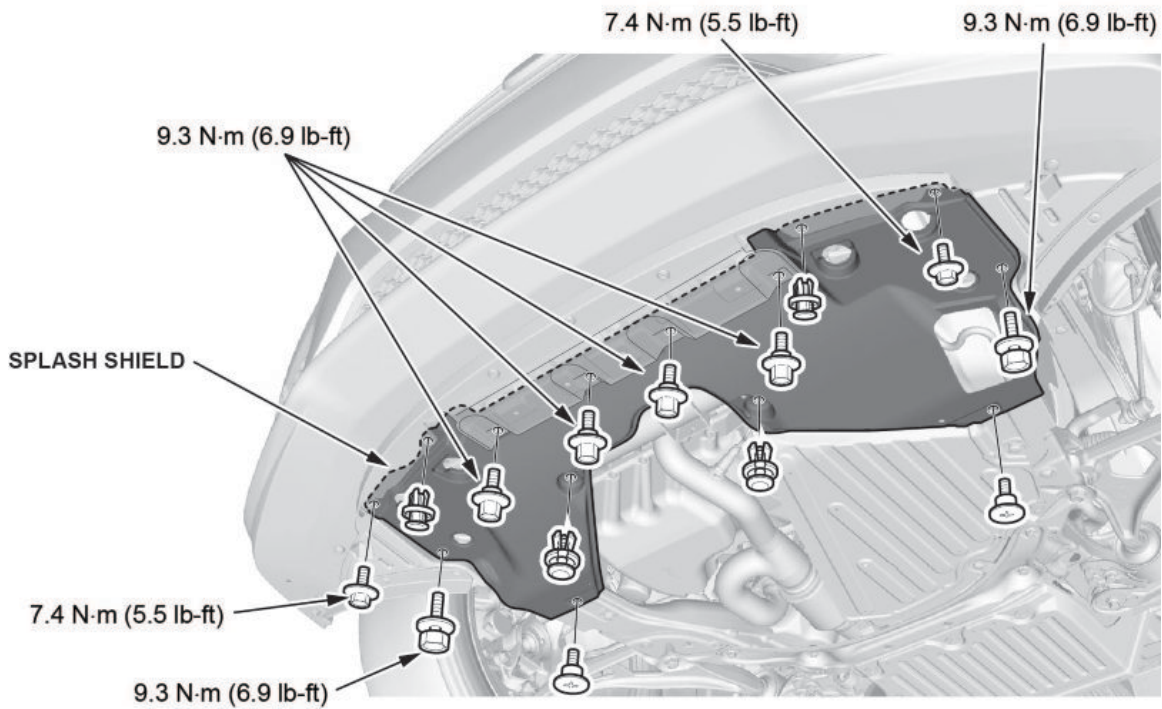

25. Drain the coolant.

25.1. Install a rubber hose on the radiator.

25.2. Loosen the drain plug, and drain the coolant.

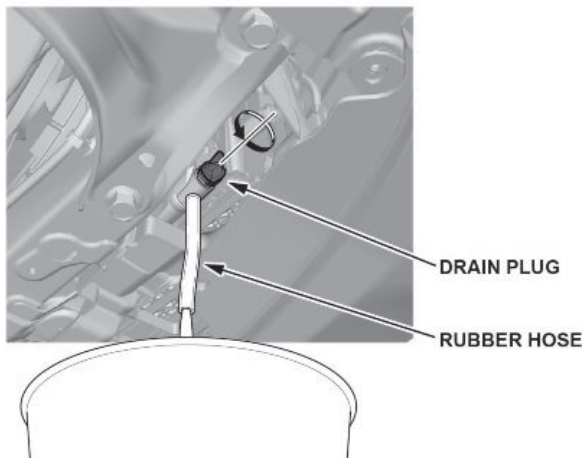

26. Lower the vehicle.

27. Disconnect the water bypass hoses from the transmission warmer.

NOTE

To prevent damage, do not bend the pipes excessively.

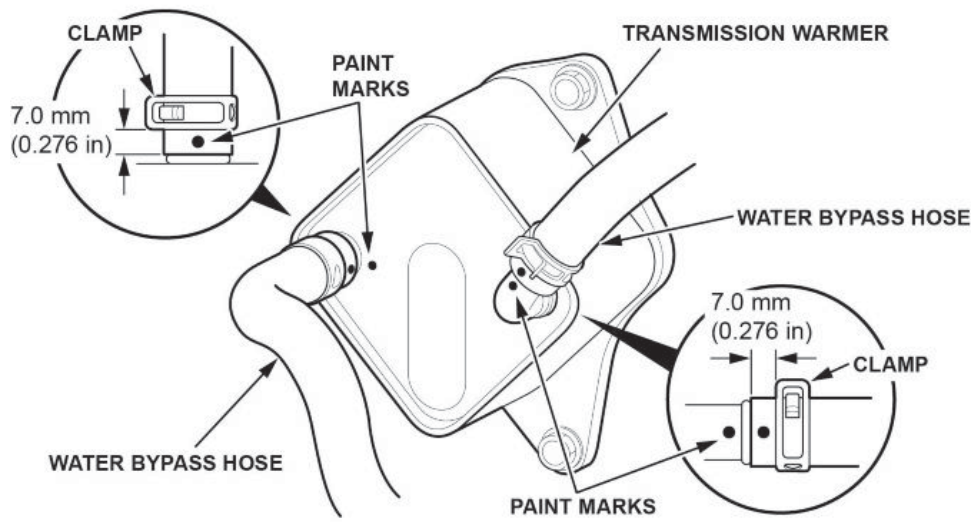

28. Install the engine support hanger.

NOTES

- Be careful when working around the windshield.
- Two sets of AAR-T1256 are required for stacking additional cross section bars.
- Be careful not to damage the hood opener cable when installing the engine support hanger at the front bulkhead.

28.1. Remove the front damper caps.

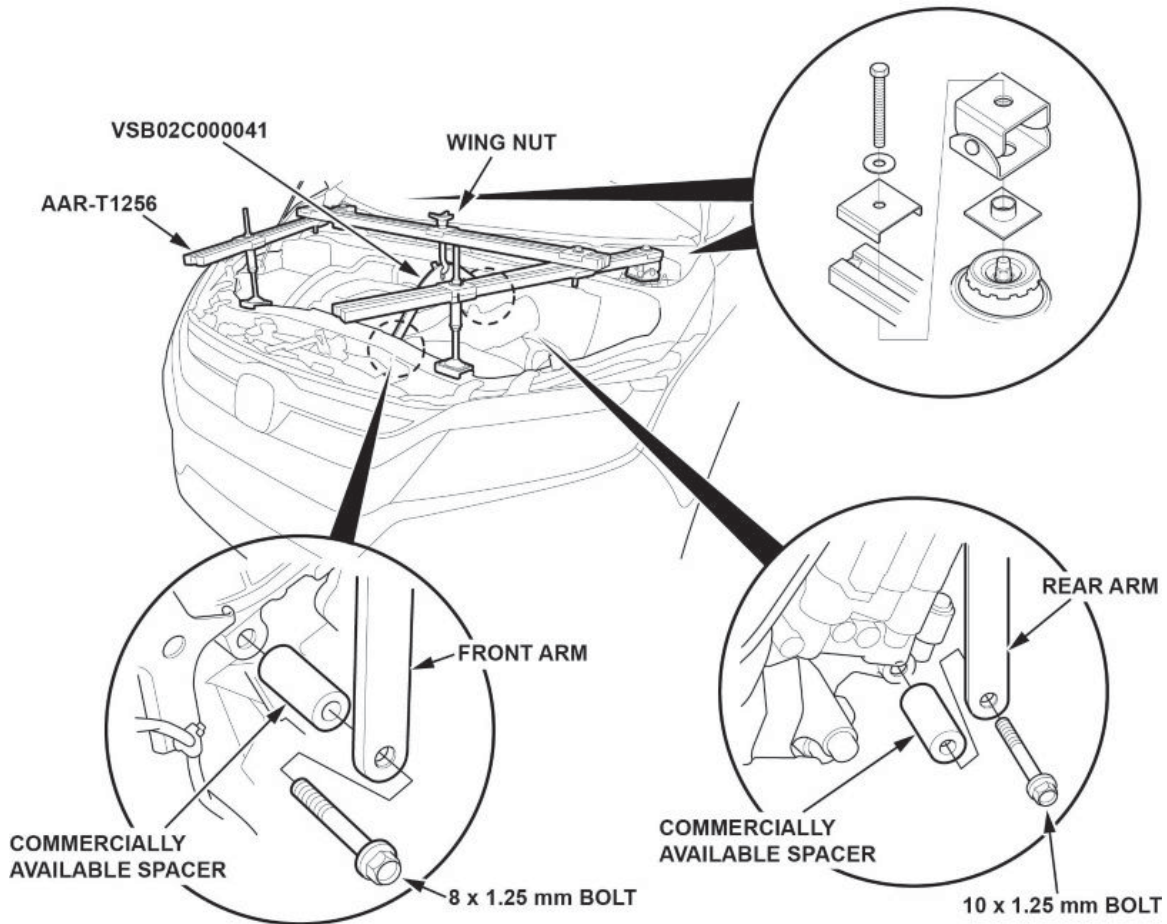

28.2. Install the engine hanger balance bar.

28.2.1. Attach the front arm to the front cylinder head with a commercially available spacer and a 10 x 1.25 mm bolt.

28.2.2. Attach the rear arm to the rear cylinder head with a commercially available spacer and a 10 x 1.25 mm bolt.

28.3. Install the engine support hanger as shown, and attach the hook to the slotted hole in the engine hanger balance bar. Tighten the wing nut by hand, and lift and support the engine/transmission.

29. Remove coil number 6.

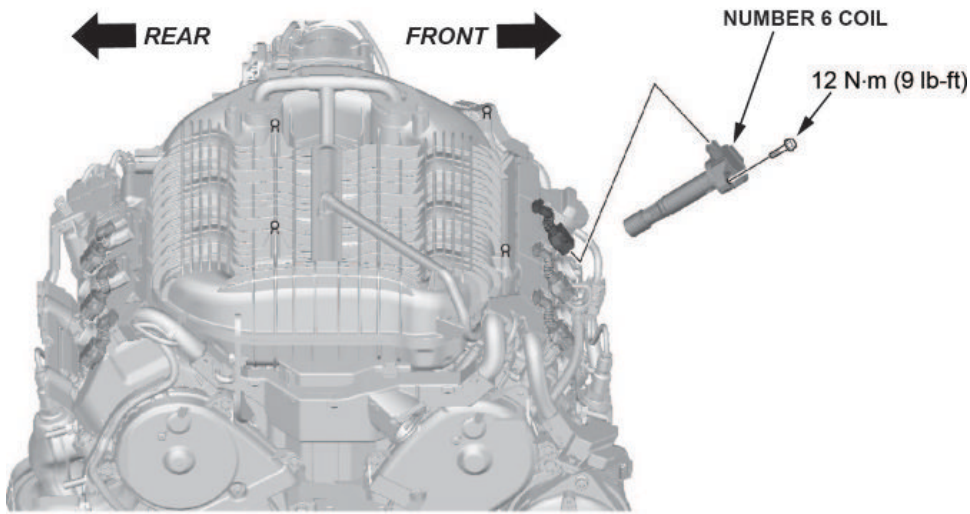

30. Remove the front engine mount stop and front engine mount mounting bolt.

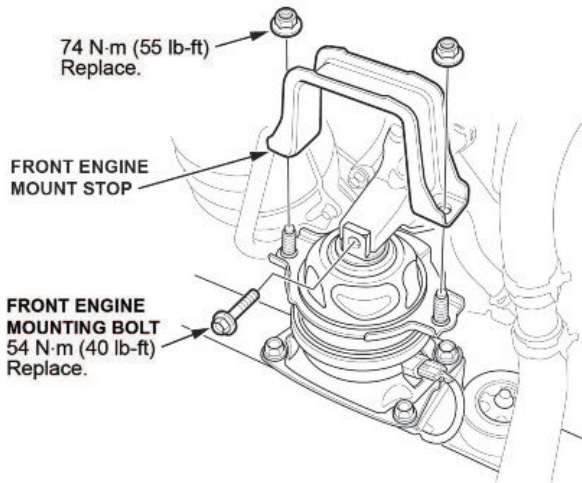

31. Remove the rear engine mount stop, heat shield, and rear engine mount mounting bolt.

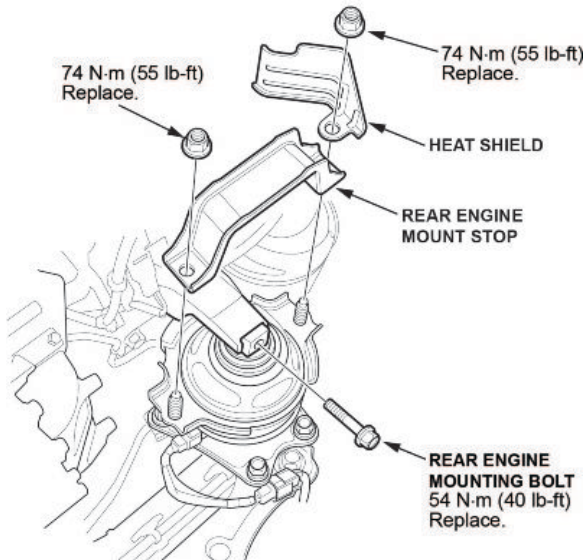

32. Disconnect the steering joint.

NOTE

Be careful not to pull out the lower shaft from the upper shaft. If it separates, use the aligning paint or stamped marks on the shafts to align them.

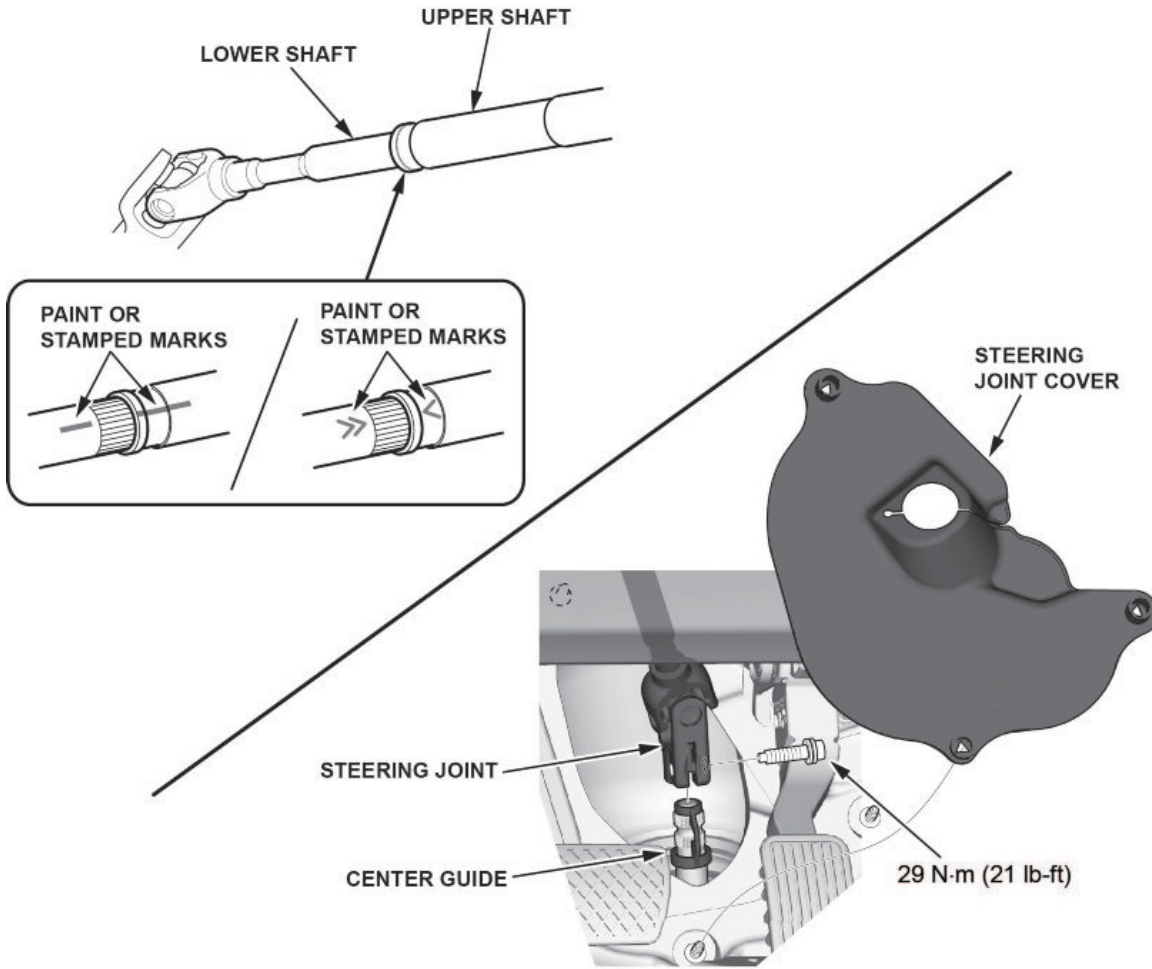

33. Lift the vehicle.

34. Remove both front wheels.

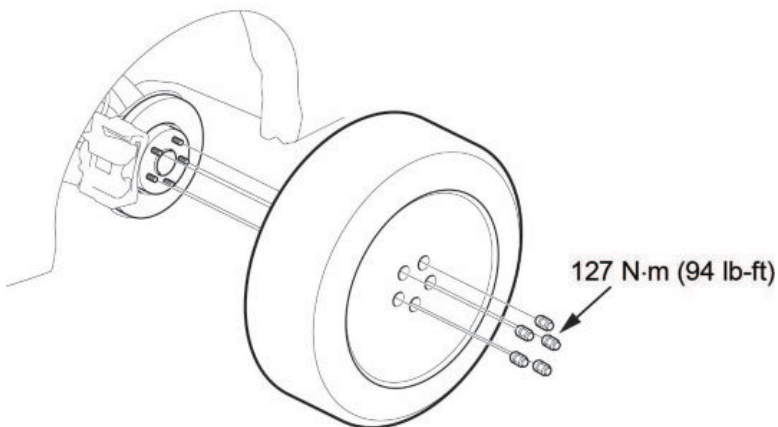

35. Remove the transmission undercover.

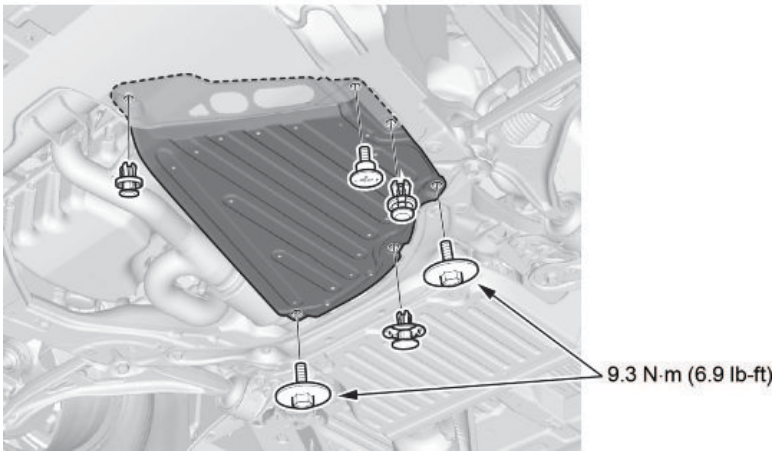

36. Disconnect the front ACM (active control engine mount) sub harness.

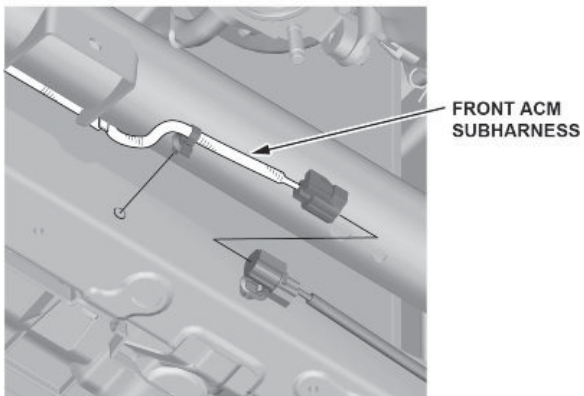

37. Remove the front subframe stiffener plate.

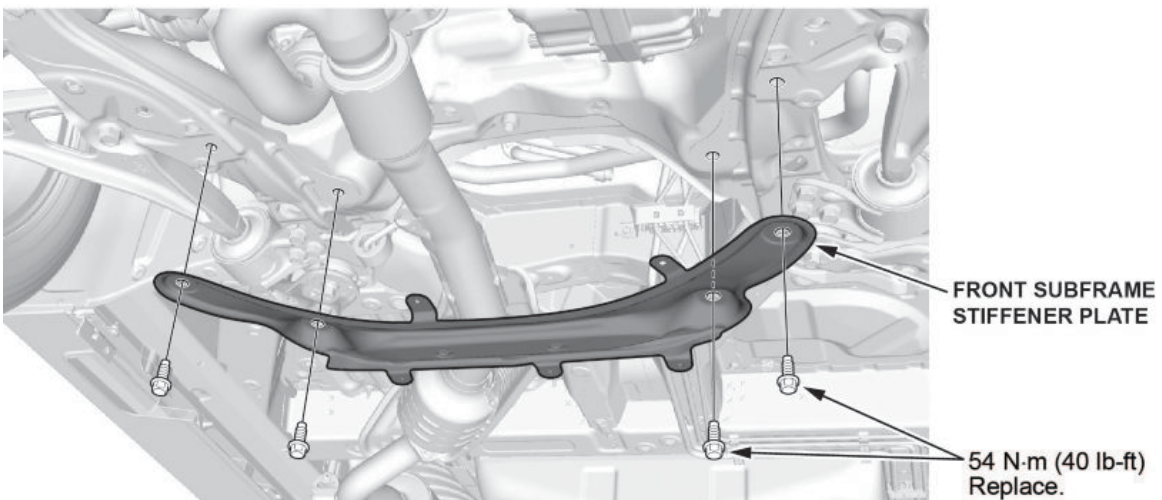

38. Remove the under-floor TWC and exhaust pipe.

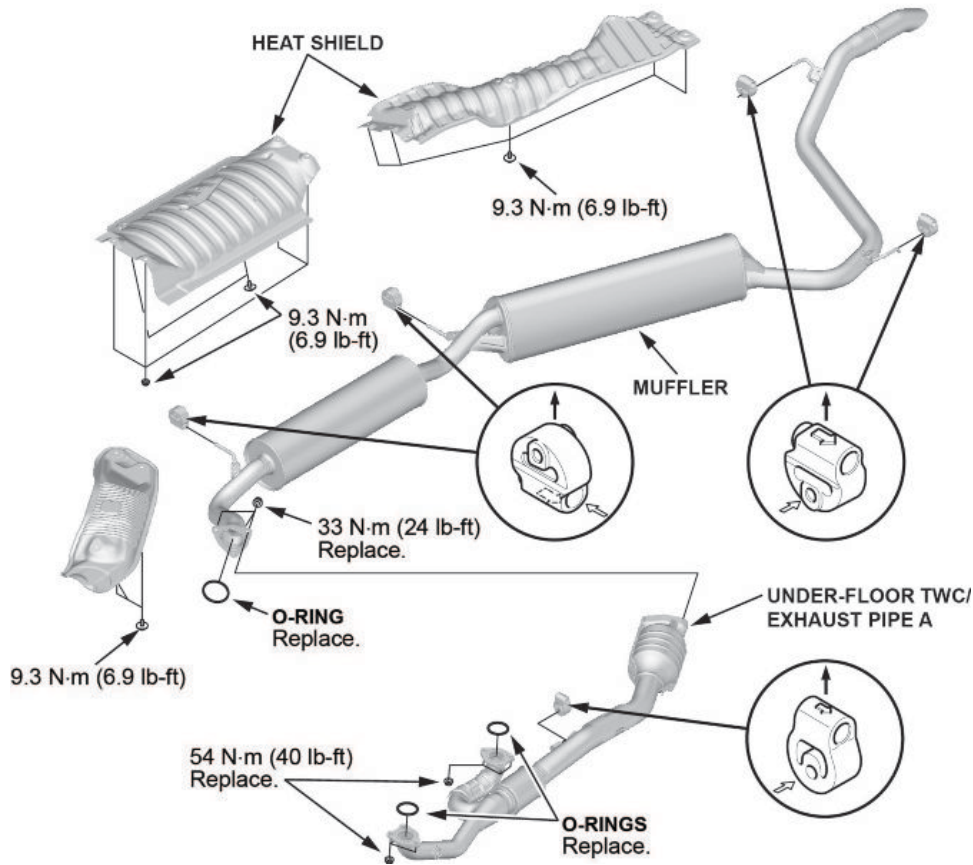

39. Disconnect the EPS motor control unit connector.

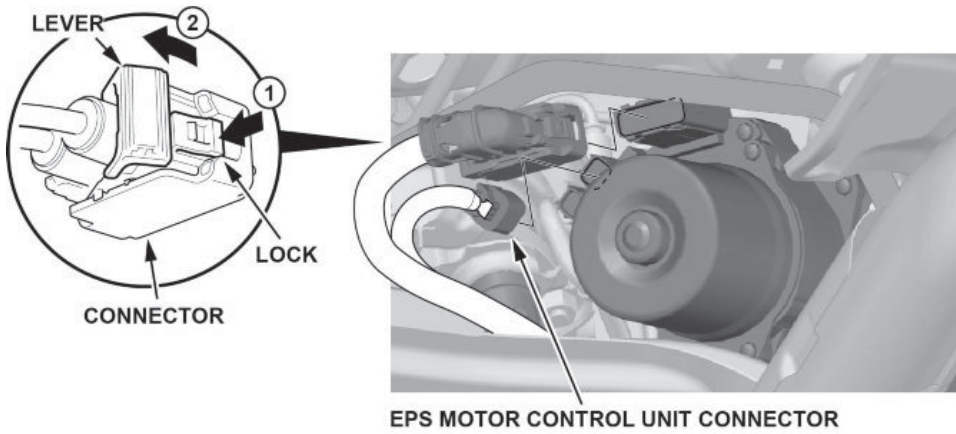

40. Disconnect both tie rod end ball joints.

40.1. Remove the cotter pin.

40.2. Remove the nut.

40.3. Disconnect the tie-rod end ball joint from the knuckle using a ball joint thread protector and a ball joint remover.

NOTES

- Be careful not to damage the ball joint boot when using the ball joint remover.
- During installation, install the new cotter pin after tightening the nut, and bend its end as shown.

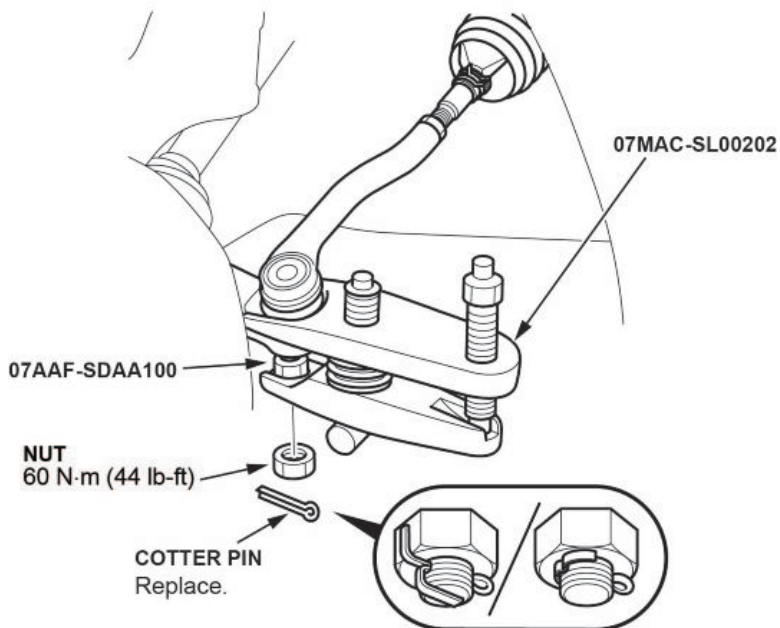

41. Disconnect both lower stabilizer links.

41.1. Remove the flange nuts while holding the respective joint pin with a hex wrench.

41.2. Remove the stabilizer link.

NOTE

The stabilizer link has a paint mark. The left stabilizer link is marked with green paint, and the right stabilizer link is marked with blue paint.

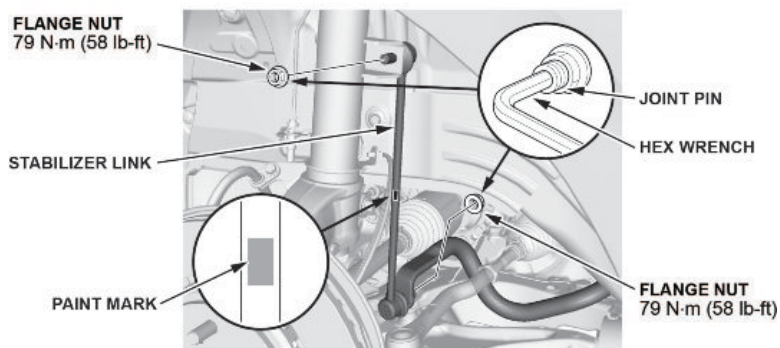

42. Remove the transmission mount.

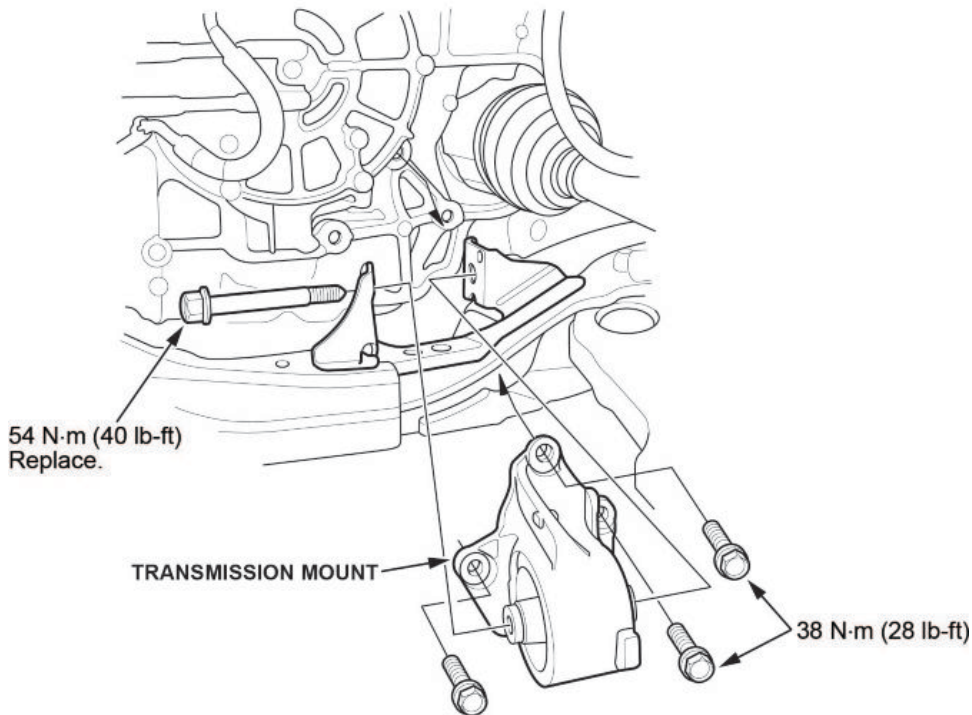

43. Install the front subframe adapter tool.

43.1. Attach the subframe adapter to the front subframe by looping the belt over the front of the front subframe, then secure the belt with its stop, and tighten the wing nut.

43.2. Raise a transmission jack, and line up the slots in the subframe adapter arms with the bolt holes on the transmission jack base. Then, securely attach them with four bolts.

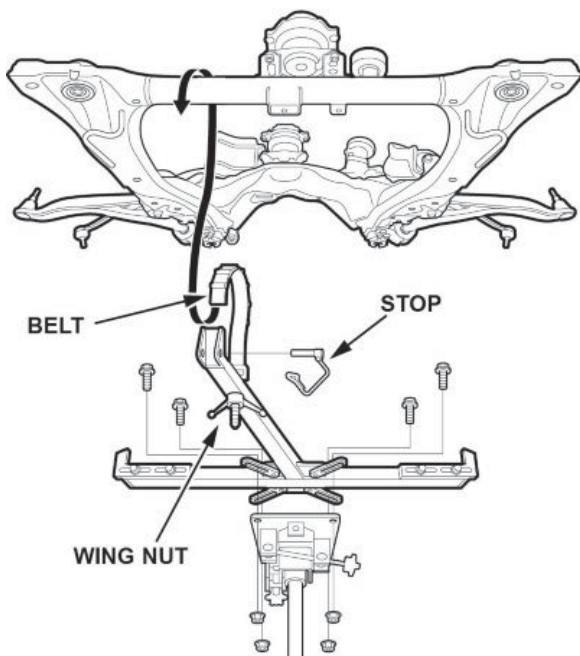

44. Remove the front subframe.

NOTES

During installation:

- After loosening the subframe bolts, be sure to replace them with new ones.
- Lift the subframe up to the body, and loosely install the new subframe mounting bolts, new front stiffener mounting bolts, front stiffeners, new rear stiffener mounting bolts, and rear stiffeners.
- Tighten the subframe mounting bolts to the torque spec in the numbered sequence shown.
- Check all of the subframe mounting bolts, and tighten them if necessary.

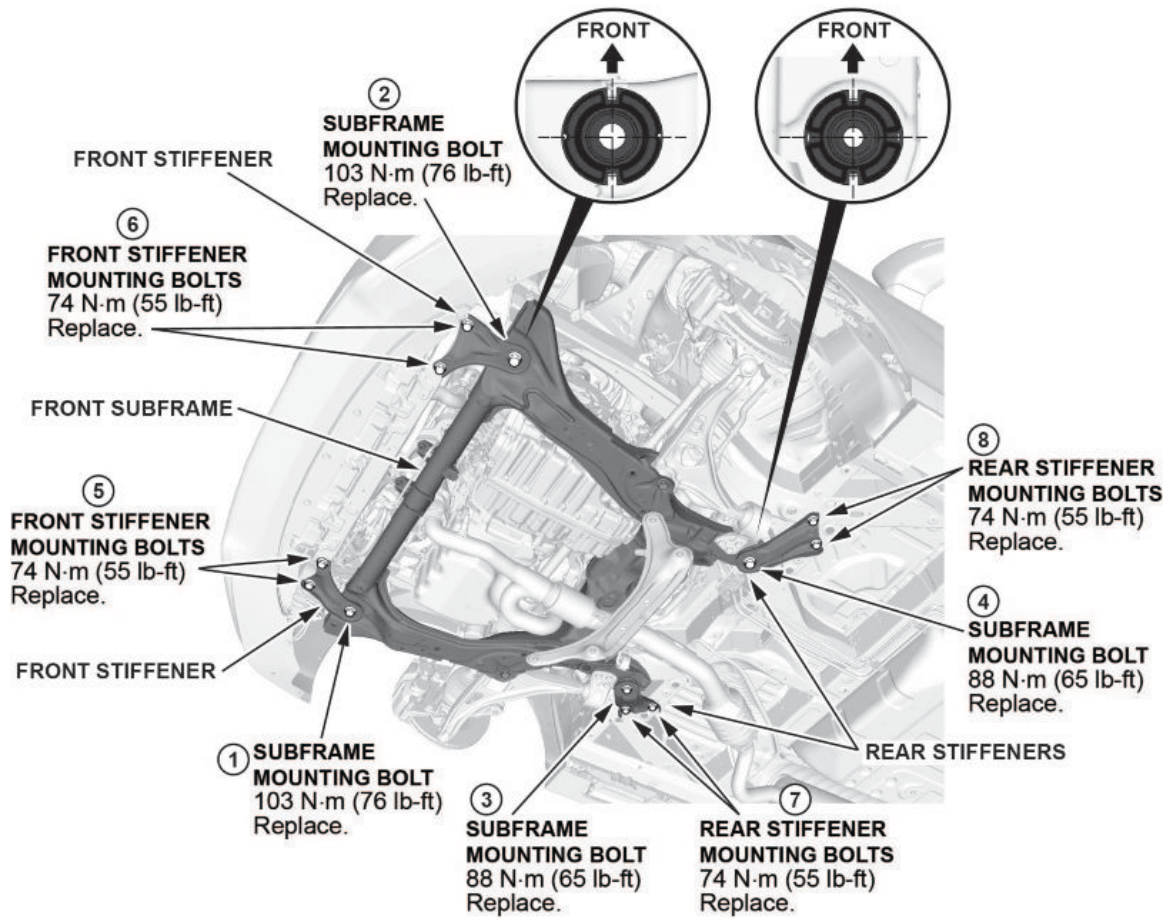

45. Support the transmission with a transmission jack.
46. Disconnect both lower arm ball joints.
 - 46.1. Remove the lock pin from the lower arm ball joint.

NOTE

During installation, install the lock pin as shown after tightening the castle nut.

- 46.2. Remove the castle nut.

NOTES

- Use a new castle nut when installing.
- Torque the castle nut to the lower torque specification, then tighten it only far enough to align the slot with the ball joint pin hole. Do not align the castle nut by loosening it.

- 46.3. Disconnect the lower ball joint from the knuckle using the ball joint thread protector and the ball joint remover.

NOTES

- Be careful not to damage the ball joint boot when installing the ball joint remover.
- During installation do the following:
 - Be careful not to damage the ball joint boot when connecting the knuckle.
 - Degrease the ball joint before connecting the threaded section and the tapered portion of the ball joint pin, the ball joint connecting hole, the threaded section, and the mating surfaces of the castle nut.

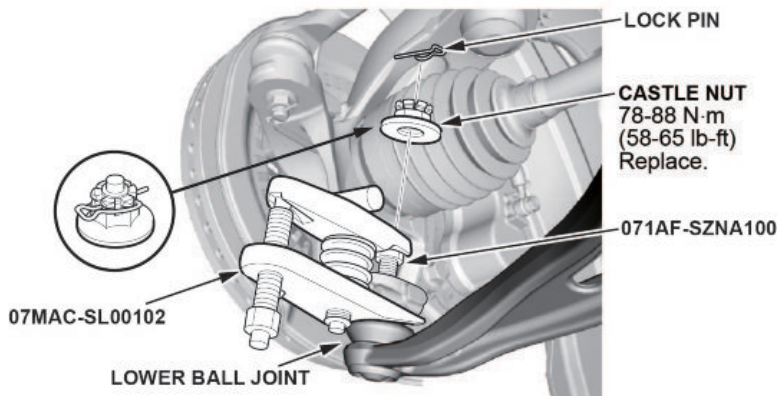

47. Disconnect both inner driveline joints.

NOTES

Secure the driveshaft to the body on both sides with a nylon strap.

47.1. Remove the left drive shaft by prying on the inboard joint with a pry bar.

NOTE

Be careful to not damage the oil seal or the end of the inboard joint with a pry bar.

47.2. Remove the left driveshaft as an assembly.

NOTE

Do not pull on the driveshaft, because the inboard joint may come apart. Pull the inboard joint straight out to avoid damaging the oil seal.

47.3. Remove the right driveshaft by driving the inboard shaft off of the intermediate shaft using a drift punch and hammer.

47.4. Remove the right driveshaft as an assembly.

NOTES

- Do not pull on the driveshaft, because the inboard joint may come apart. Pull the inboard joint straight out.
- Use new snap rings when installing the driveshaft.

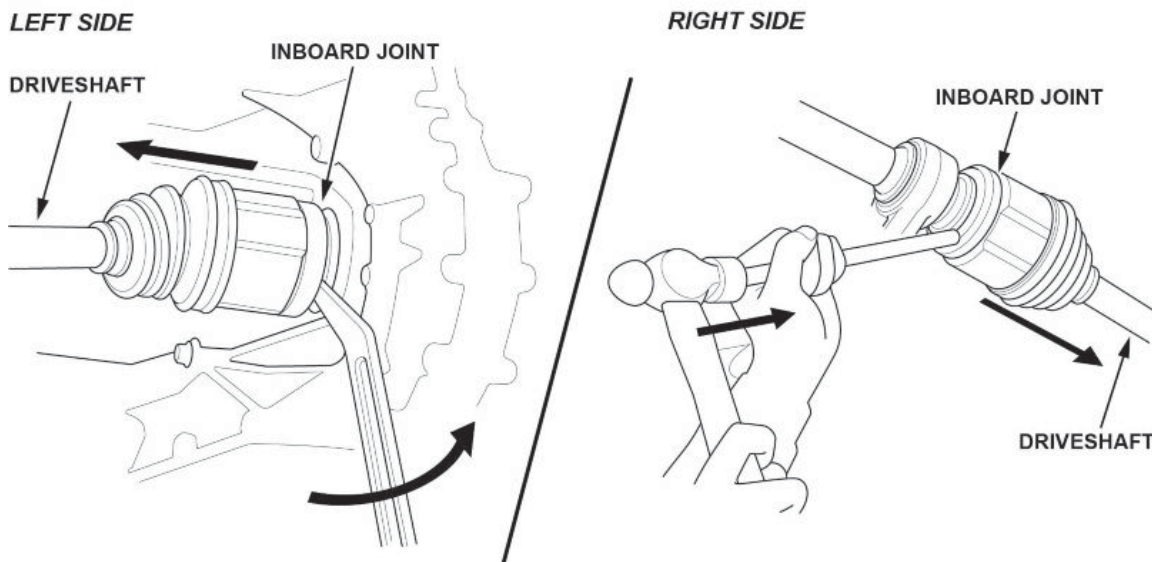

48. Remove the intermediate shaft assembly.

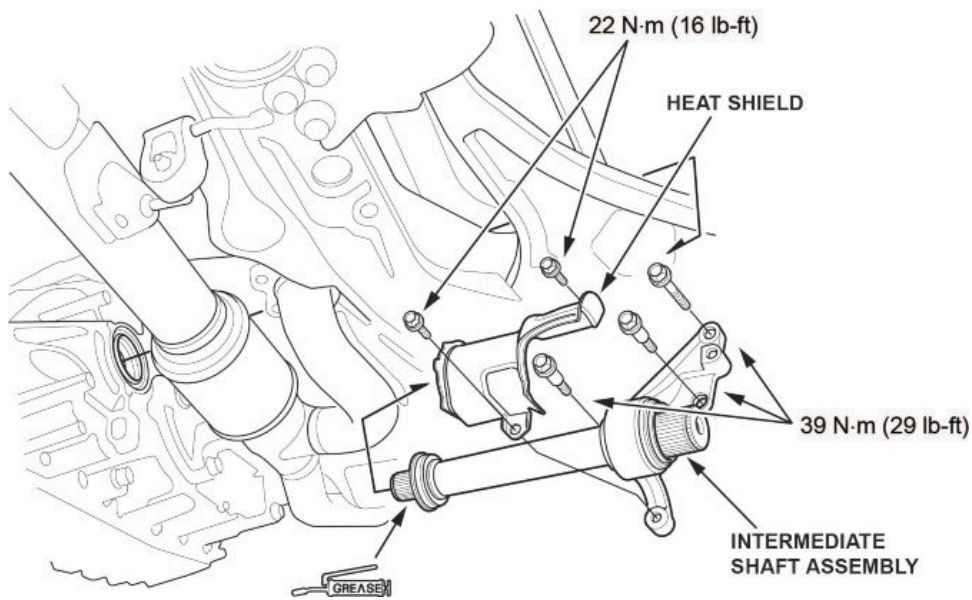

49. Disconnect the CKP sensor connector.

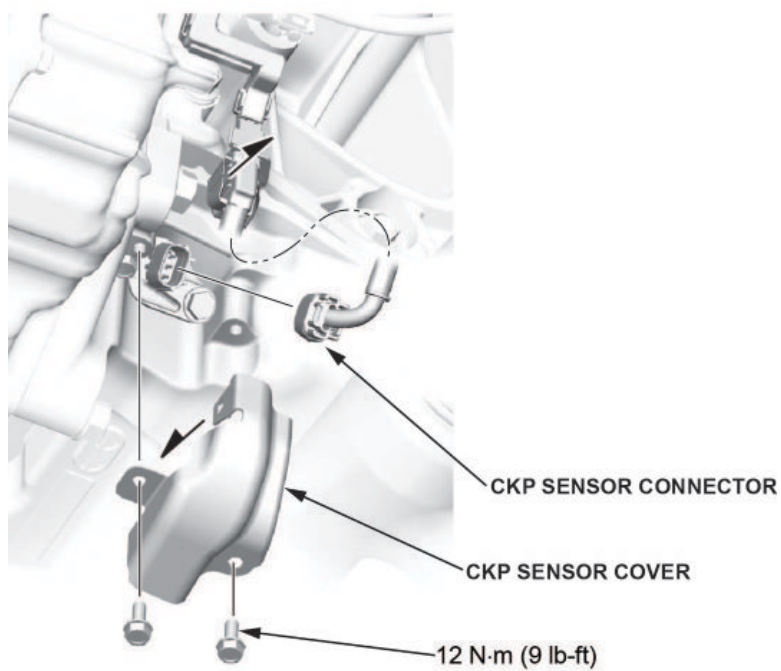

50. Remove the front engine mount bracket.

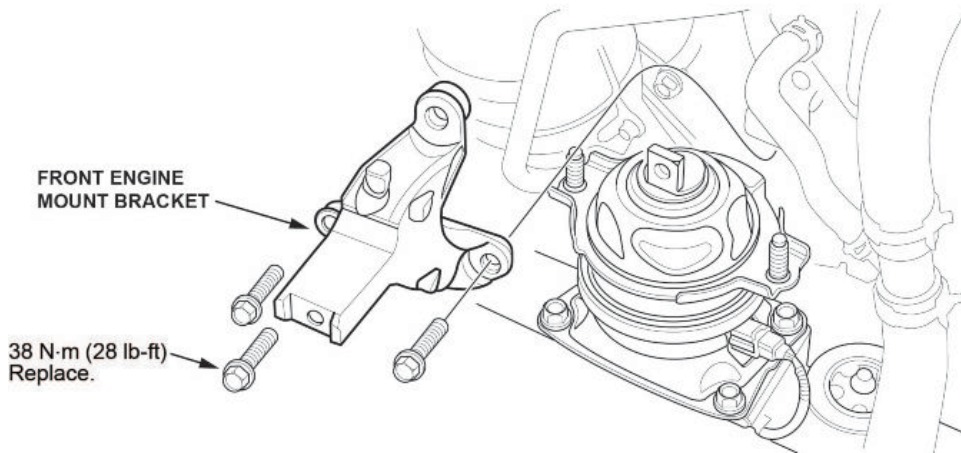

51. Disconnect the transmission ground strap.

52. Remove the torque converter cover.

53. Remove the torque converter bolts.

54. Remove the remaining transmission mounting bolts.

55. Remove the transmission.

56. Remove the dowel pins, and install them on the new transmission.

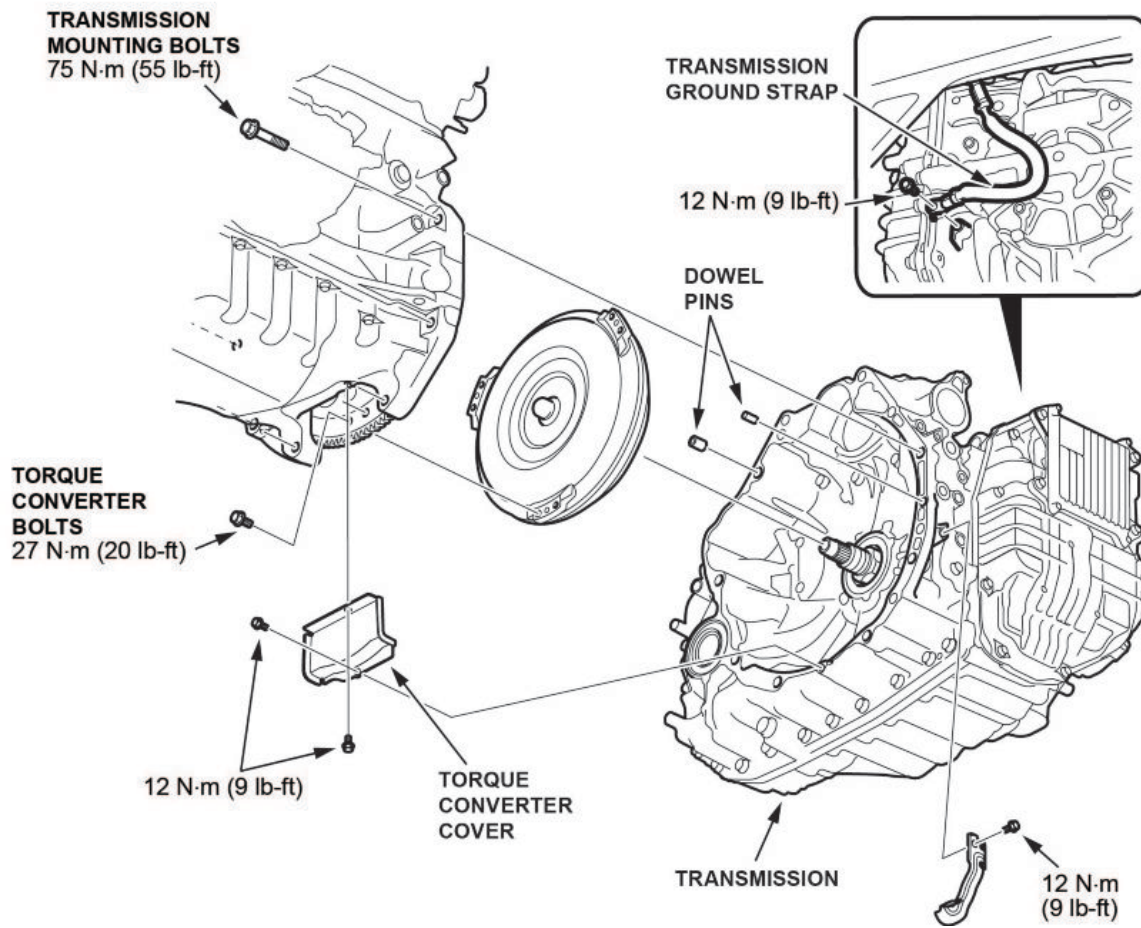

57. Install the new transmission.

58. Install all removed parts in the reverse order of removal except the intake air duct and the front bulkhead cover. The battery terminals will still need to be inspected.

NOTES

- Make sure to replace all must-replace parts.
 - The reman transmission comes prefilled with AT. It does not need to be filled.
 - Use new snap rings on drive lines.
59. Fill the cooling system with coolant.
At coolant change: **7.4 L (1.90 US gal)** with coolant reservoir included.
60. Do the keyless access registration.
61. Inspect the positive and negative battery terminals.

NOTICE

- Battery terminal installation on this vehicle is critical. Failure to follow the terminal installation or inspection procedures could cause electrical problems, stalling, and/or DTCs to set. Do not over torque the terminals, and do not use an impact gun.
- Battery terminal installation must be level or below the post. See GOOD and NO GOOD example pictures.

Compare both of the battery terminals to the examples below.

 **GOOD**



 **NO GOOD**



Do the battery terminals look like the good example?

Yes - Go to step 62.

No - Go to **TERMINAL REPAIR**.

62. While holding down the terminal, torque both positive and negative clamps to **4-6 N•m (35-53 lb-in)**.

NOTE

Do not over torque the terminal.

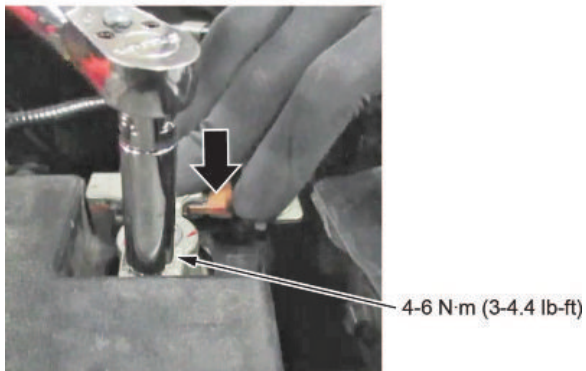

63. Make sure the connection is tight by wiggling the terminals back and forth.

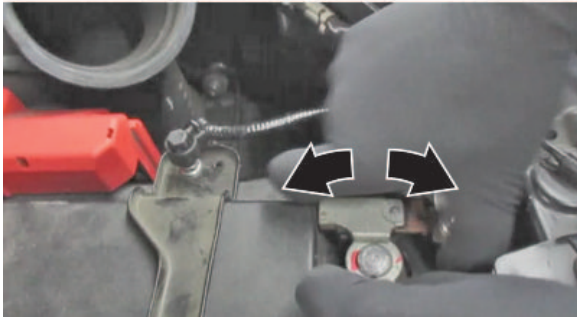

Are both terminals secure?

Yes - Apply multipurpose grease to the terminals to prevent corrosion, and install the air intake duct and the bulkhead cover. Then, do the following steps:

63.1. Check the front-end alignment.

63.2. Do the VSA Sensor Neutral Position Memorization procedure.

63.3. Test-drive the vehicle, and confirm the repair.

No - Go to TERMINAL REPAIR.

TERMINAL REPAIR

1. Remove the terminal or terminals, and clean the post using an approved battery terminal cleaner or equivalent.

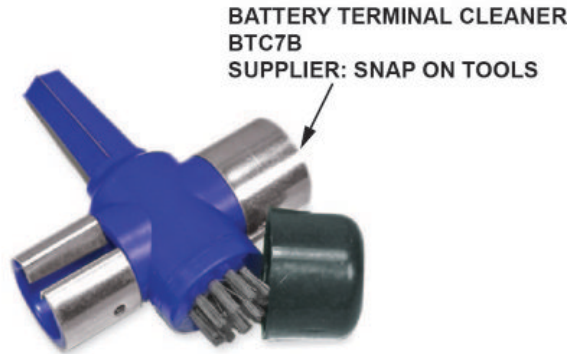

- 1.1. Make sure the ignition is turned to OFF.
- 1.2. Disconnect and isolate the negative cable with the battery sensor from the battery.

NOTES

- Always disconnect the negative side first.
 - To prevent damage to the connector, do not hold it when removing the battery terminal.
 - Do not disconnect the battery sensor from the cable.
- 1.3. Open the terminal cover.
 - 1.4. Disconnect the terminal from the battery and clean them.

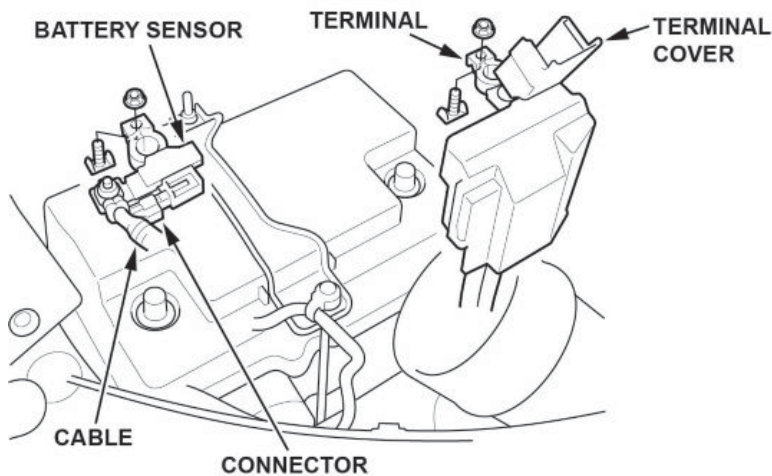

2. While holding down the terminal, torque both positive and negative clamps to **4-6 N•m (35-53 lb-in)**.

NOTES

- Do not over torque the terminal.
- Always connect the positive side first.

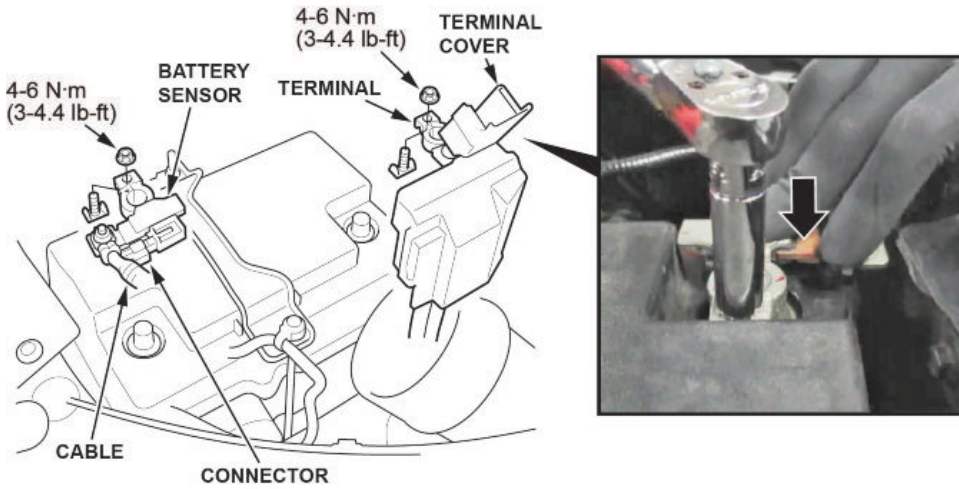

3. Compare both of the battery terminals to the examples below.

 **GOOD**



 **NO GOOD**



Do the battery terminals look like the good example?

Yes - Go to step 4.

No - Go to REPLACE BATTERY TERMINAL.

4. Make sure the connection is tight by wiggling the terminals back and forth.

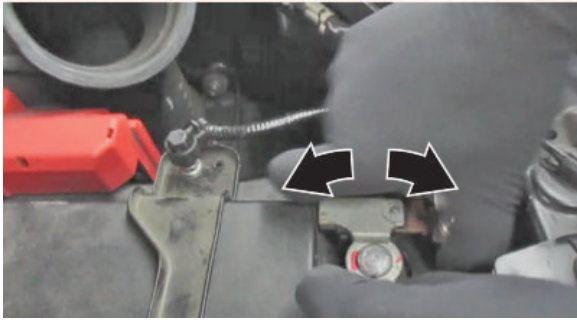

Are both terminals secure?

Yes - Apply multipurpose grease to the terminals to prevent corrosion, and install the air intake duct and the bulkhead cover. Then do the following steps:

- 4.1. Check the front-end alignment.
- 4.2. Do the VSA Sensor Neutral Position Memorization procedure.
- 4.3. Test-drive the vehicle, and confirm the repair.

No - Go to REPLACE BATTERY TERMINAL.

REPLACE BATTERY TERMINAL

1. Remove the battery terminal that does not sit at or below the top of the post.
2. Install a new terminal, and torque the terminal and clamp nut to **4-6 N•m (35-53 lb-in)** while holding it down.

NOTES

- Always disconnect the negative side first.
 - To prevent damage, do not hold the connector when removing the battery terminal.
 - Do not disconnect the battery sensor from the cable.
3. Compare both of the battery terminals to the examples below.

 **GOOD**



 **NO GOOD**



Do the battery terminals look like the good example?

Yes - Go to step 4.

No - Go to BATTERY REPLACEMENT, BATTERY RESISTANCE RESET PROCEDURE.

4. Make sure the connection is tight by wiggling the terminals back and forth.

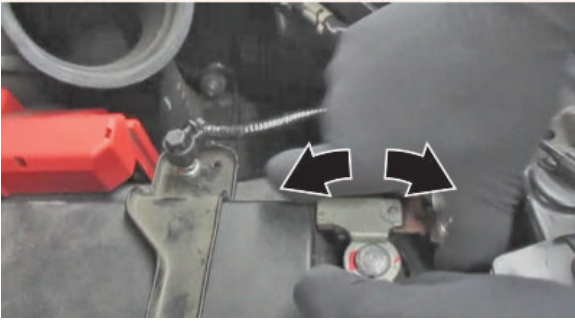

Are both terminals secure?

Yes - Apply multipurpose grease to the terminals to prevent corrosion, and install the air intake duct and the bulkhead cover. Then, go do the following steps:

- 4.1. Check the front-end alignment.
- 4.2. Do the VSA Sensor Neutral Position Memorization procedure.
- 4.3. Test-drive the vehicle, and confirm the repair.

No - Go to BATTERY REPLACEMENT, BATTERY RESISTANCE RESET PROCEDURE.

BATTERY REPLACEMENT, BATTERY RESISTANCE RESET PROCEDURE

1. Disconnect the battery terminals.
 - 1.1. Make sure the ignition is turned to OFF.
 - 1.2. Disconnect and isolate the negative cable with the battery sensor from the battery.

NOTES

- Always disconnect the negative side first.
- To prevent damage to the connector, do not hold it when removing the battery terminal.
- Do not disconnect the battery sensor from the cable.

- 1.3. Open the terminal cover.
- 1.4. Disconnect the terminal from the battery.

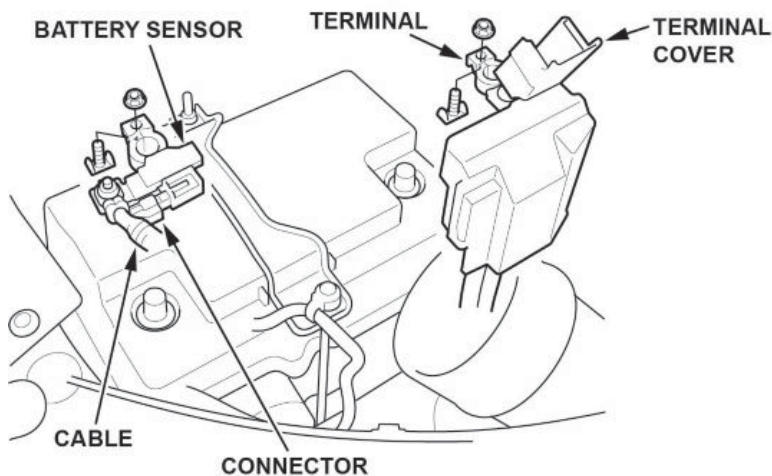

2. Remove the setting plate.
3. Remove the battery cover.
4. Remove the battery.

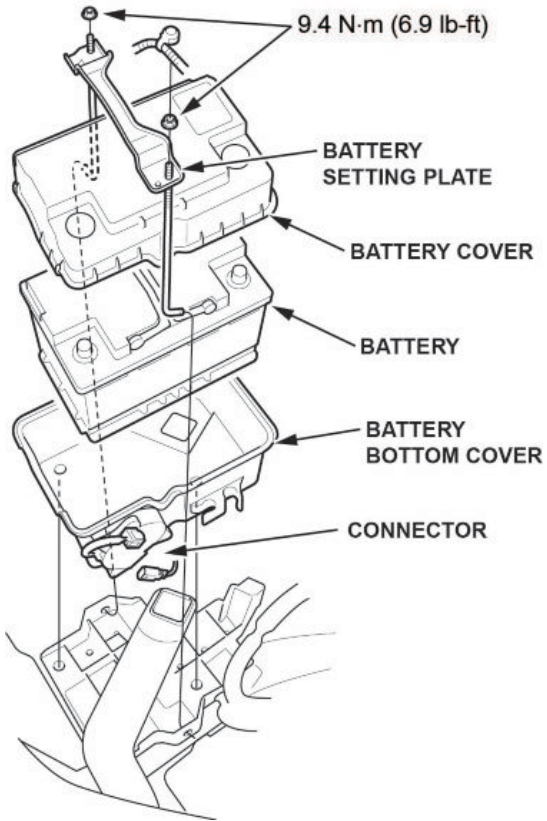

5. Install a new battery. Then reinstall the battery cover, and the setting plate in the reverse order of removal.
6. While holding down the terminal, torque both positive and negative clamps to **4-6 N·m (35-53 lb-in)**.

NOTES

- Do not over torque the terminal.
- Always connect the positive side first.

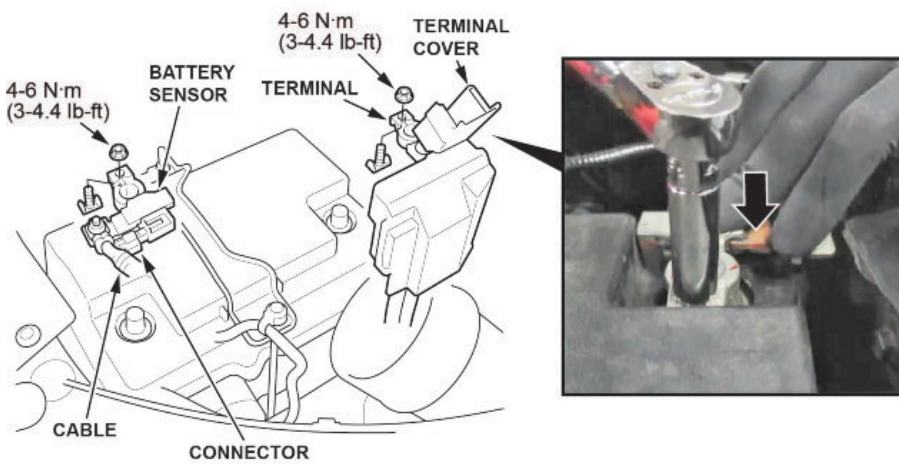

7. Compare both of the battery terminals to the examples below.

 **GOOD**



 **NO GOOD**



Do the battery terminals look like the good example?

Yes - Go to step 8.

No - Remove and reinstall the terminals, then go back to step 7.

8. Make sure the connection is tight by wiggling the terminals back and forth.

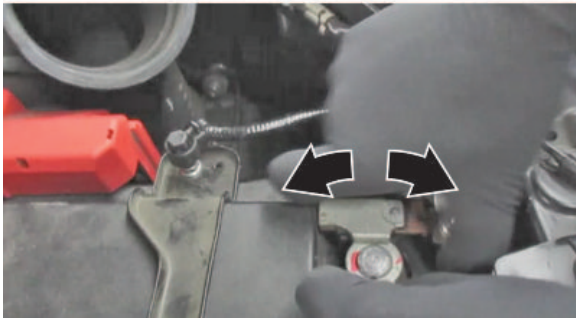

Are both terminals secure?

Yes - Apply multipurpose grease to the terminals to prevent corrosion and install the air intake duct and bulkhead cover. Then go to BATTERY INTERNAL RESISTANCE RESET.

No - Remove and reinstall the terminals, then go to step 7.

BATTERY INTERNAL RESISTANCE RESET

NOTE

Do this procedure only if the battery was replaced.

1. Make sure all electrical systems (A/C, audio, lights, etc) are turned off.
2. Turn the ignition to OFF.
3. Turn the ignition to ACCESSORY.
4. Turn the ignition to ON.
5. Start the engine, and let it idle for **1 minute** or more.
6. Turn the ignition to OFF.

7. Repeat steps 3 thru 6 at least four times.

NOTE

The internal resistance of the battery may not be updated if the engine starts up immediately from the OFF position. It has to go through the ACCESSORY and ON position.

8. Turn the ignition to ON.
9. Connect the i-HDS and select **PGM-FI**.
10. Check **IDLE STOP INHIBIT (BATTERY DETERIORATION)** in the **Data List**.

Normal - The battery internal resistance test is complete.

INHIBITED - Replace the battery, then do the battery internal resistance reset procedure again.

11. Turn the ignition to OFF, and disconnect the i-HDS.
12. Check the front-end alignment.
13. Do the VSA Sensor Neutral Position Memorization procedure.
14. Test-drive the vehicle, and confirm the repair.

END