

March 29, 2019

Version 1

Safety Recall: 2014-19 MDX Inner Taillights

AFFECTED VEHICLES

Year	Model	Trim	VIN Range
2014-19	MDX	ALL	Check the iN VIN status for eligibility.
2017-19	MDX Sport Hybrid	ALL	Check the iN VIN status for eligibility.

BACKGROUND

An uneven sealing surface allows moisture to enter the inner taillight(s), causing one or all of the taillights not to work.

CLIENT NOTIFICATION

Owners of affected vehicles will be sent a notification of this campaign.

Do an iN VIN status inquiry to make sure the vehicle is shown as eligible.

Some vehicles affected by this campaign may be in your new or used vehicle inventory.

Failure to repair a vehicle subject to a recall or campaign may subject your dealership to claims or lawsuits from the client or anyone else harmed as a result of such failure. To see if a vehicle in inventory is affected by this safety recall, do a VIN status inquiry before selling it.

CORRECTIVE ACTION

Following the inspection procedures and based on the results, do one or more of the following:

- Replace the inner taillights.
- Remove moisture from the inner taillight(s).
- Modify a portion of the inner taillight sealing surface, and install new updated taillight gasket.
- Install a new inner taillight sub harness.

CLIENT INFORMATION: The information in this bulletin is intended for use only by skilled technicians who have the proper tools, equipment, and training to correctly and safely maintain your vehicle. These procedures should not be attempted by "do-it-yourselfers," and you should not assume this bulletin applies to your vehicle, or that your vehicle has the condition described. To determine whether this information applies, contact an authorized Acura automobile dealer.

PARTS INFORMATION

Part Name	Quantity	Part Number
Right Inner Taillight (Right Lid Light Assembly)	1	34150-TZ5-H03
Left Inner Taillight (Left Lid Light Assembly)	1	34155-TZ5-H03
Right Inner Taillight (Right Lid Light Assembly) (A-Spec)	1	34150-TZ5-A72
Left Inner Taillight (Left Lid Light Assembly) (A-Spec)	1	34155-TZ5-A72
Inner Taillight Repair Kit	1	06340-TZ5-A00
Fuse (7.5 A) (depending on trim level)	1	38221-SNA-A31
Fuse (10 A) (depending on trim level)	1	38221-SNA-A41

TOOL INFORMATION

Part Name	Part Number	Quantity
MDX Taillight Jig Set	07AAG-TZ5A100	1
Right Angle Grinder with 1/4" Chuck	Commercially Available	1

NOTES

- Two MDX taillight jig sets will be provided to each dealer. The part number is provided only in case additional sets are needed to be ordered.
- If replacement bits are needed, use ROTOZIP ZB8 1/8" Drywall Bit or equivalent (Commercially Available).

WARRANTY CLAIM INFORMATION

Operation Number	Description	Flat Rate Time	Defect Code	Symptom Code	Template ID	Failed Part Number
7140B0	REPAIR PROCEDURE A Inspect taillight operation, modify left and right inner taillights, and install tailgate sub harness.	0.9 hr	6LL00	M4900	B19019A	34150-TZ5-H02
7140B0	REPAIR PROCEDURE A Inspect taillight operation, modify left and right inner taillights, and install tailgate sub harness.	0.9 hr	6LL00	M4900	B19019B	34150-TZ5-H02
A	Drain water from one or both taillights.	0.2 hr				
7141E6	REPAIR PROCEDURE B (NON A-SPEC) Inspect taillight operation, and replace left and right inner taillights.	0.6 hr	6LL00	M4900	B19019C	34150-TZ5-H02
7141E6	REPAIR PROCEDURE B (A-SPEC) Inspect taillight operation, and replace left and right inner taillights.	0.6 hr	6LL00	M4900	B19019D	34150-TZ5-H02

Skill Level: Repair Technician

INSPECTION PROCEDURE

Turn on the headlights, and check taillight operation.

- If all of the taillights come on, do REPAIR PROCEDURE A (MODIFY BOTH INNER TAILLIGHTS).
- If none of the taillights come on, check the Small Light Fuse in the under-hood fuse box (depending on the trim level, this will be either C22 (10 A) in the under-hood fuse/relay box or B11 (7.5 A) in the main under-hood fuse box). Replace the fuse, and do REPAIR PROCEDURE B (REPLACE BOTH INNER TAILLIGHTS).

NOTE

If the fuse is not blown, follow normal system troubleshooting, then do the inspection procedure again.

- If one or both of the outer taillights come on but the inner taillights do not, do REPAIR PROCEDURE B (REPLACE BOTH INNER TAILLIGHTS).
- If both outer taillights and one of the inner taillights come on, do REPAIR PROCEDURE B (REPLACE BOTH INNER TAILLIGHTS).

REPAIR PROCEDURE A (MODIFY BOTH INNER TAILLIGHTS)

1. Open the tailgate.

NOTE

Manually open and close the tailgate. Do not use the power tailgate function (if equipped) during the repair to avoid damaging the tailgate support struts.

2. Remove the tailgate upper trim panel, then remove the side trim panels.

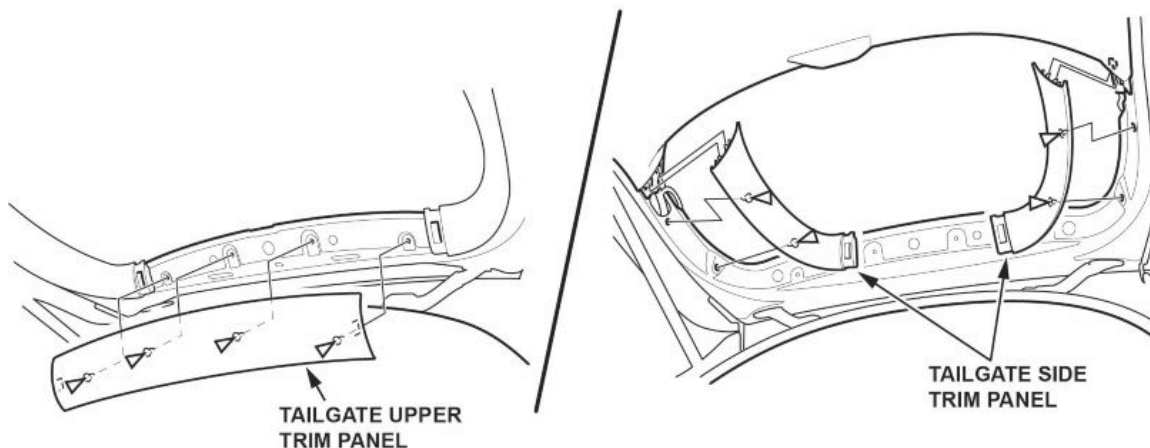

3. Remove the pull pocket, and disconnect the power tailgate switch connector.

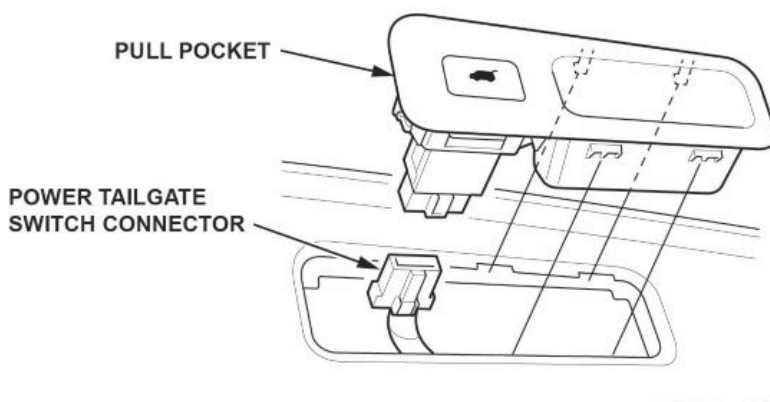

- Remove the tailgate lower trim panel, then disconnect the tailgate light connectors.

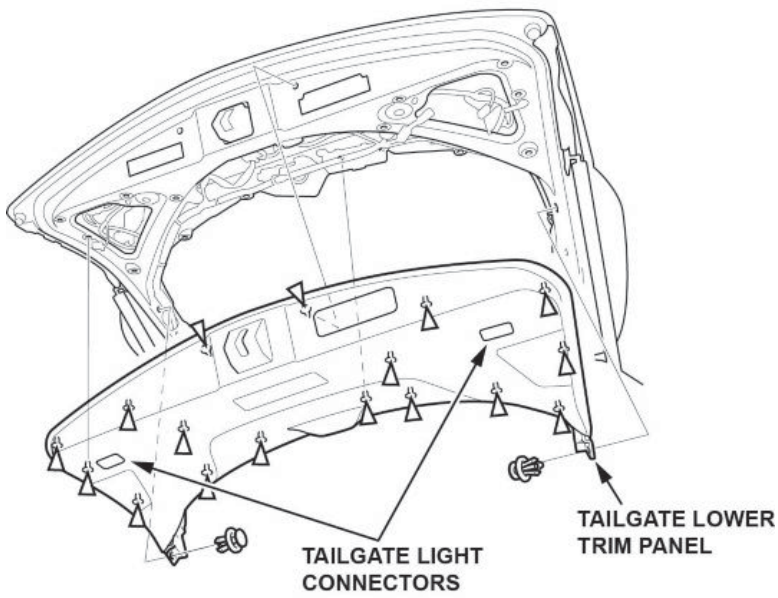

- Disconnect the license sub harness connector, remove the five nuts, release the pins from the clips, then remove the rear license trim.

INSIDE THE TAILGATE

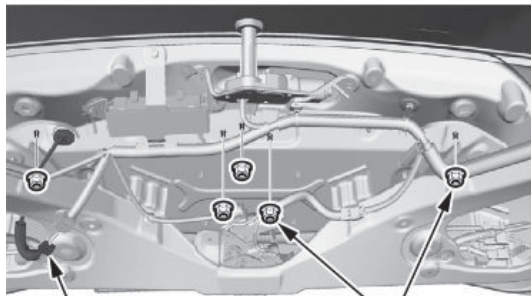

LICENSE SUBHARNESS CONNECTOR

4.9 N-m (3.6 lb-ft)

OUTSIDE THE TAILGATE

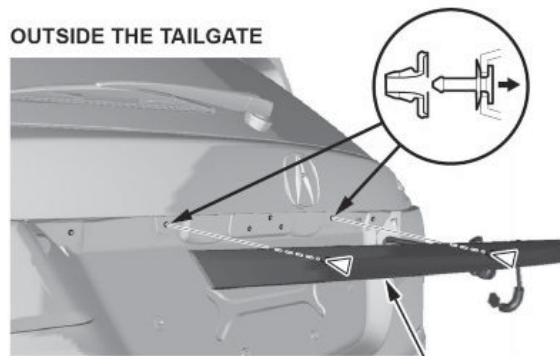

REAR LICENSE TRIM

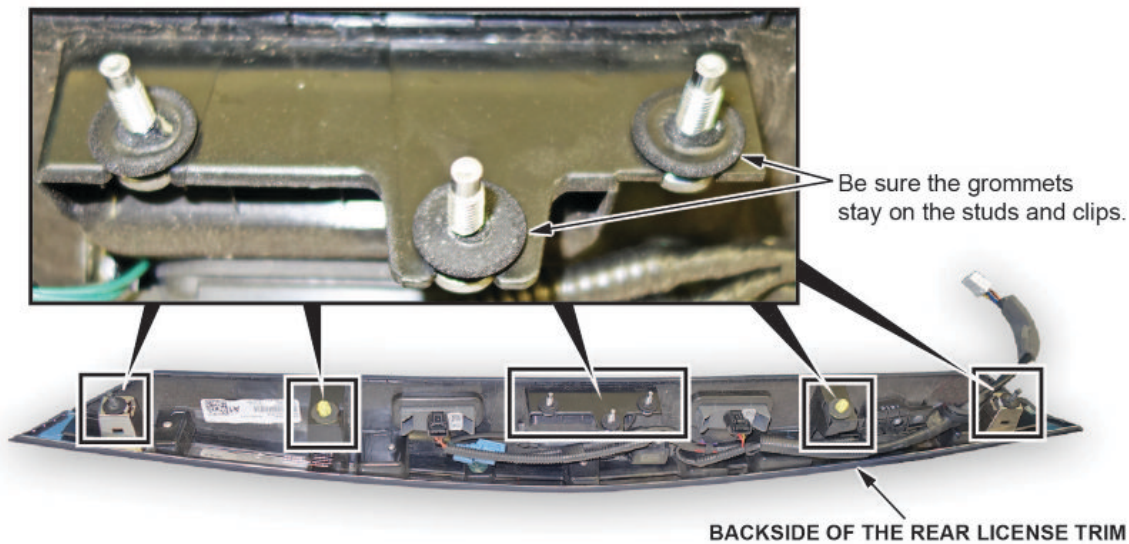

6. Disconnect both inner taillight connectors.

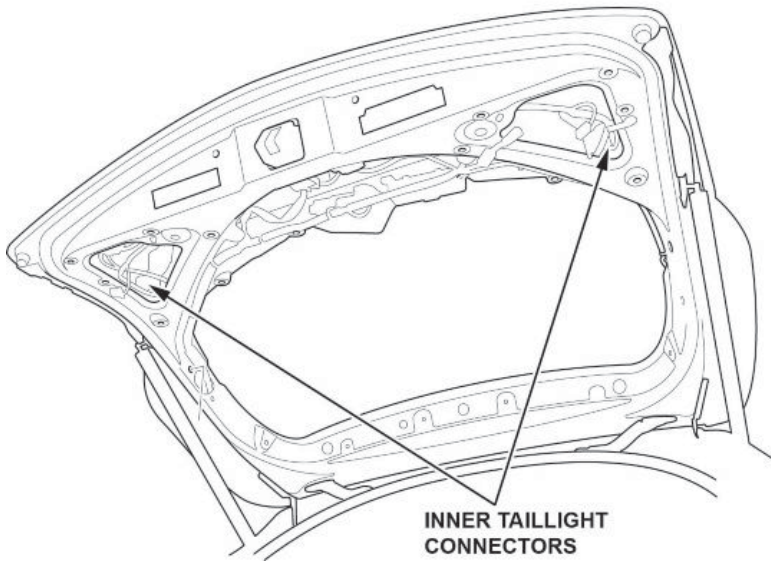

7. Remove the two bolts and two nuts behind each inner taillight, then remove the inner taillights.

NOTE

Be sure to completely remove the old inner taillight gasket.

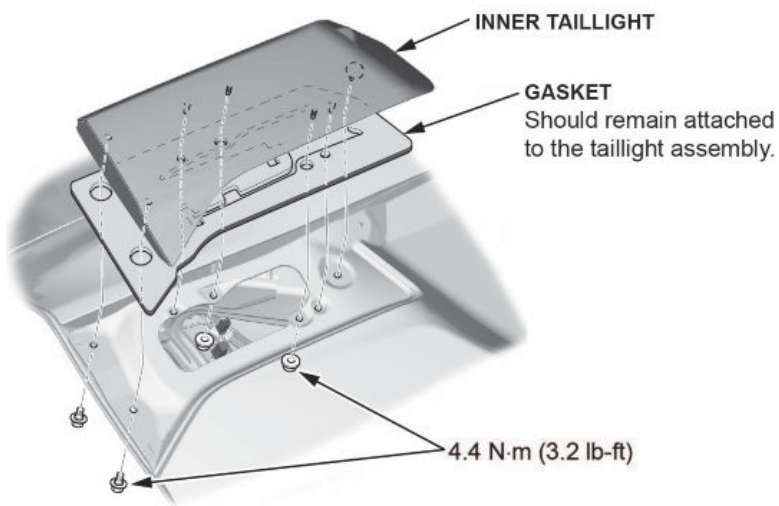

8. Place the inner taillight on a soft, clean cloth to prevent lens damage.

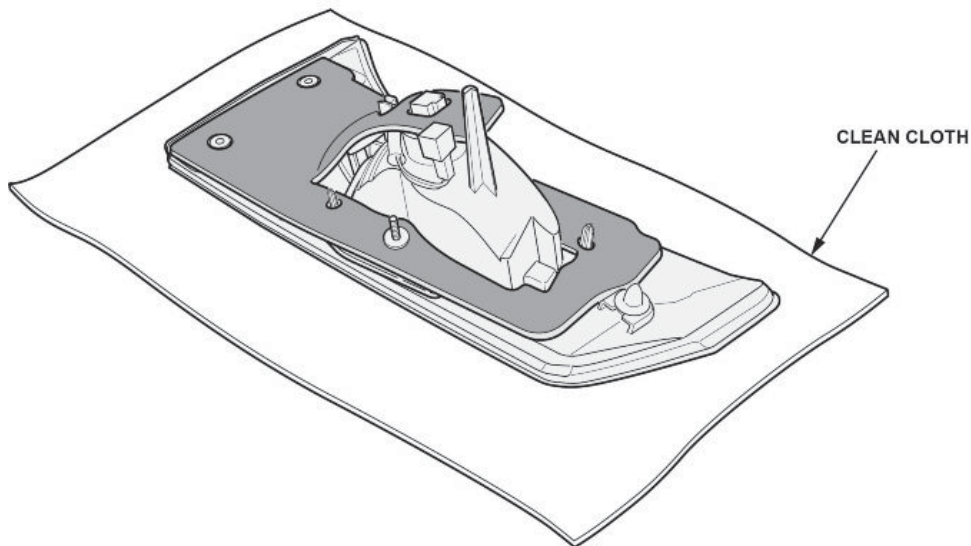

9. Remove the original gasket from the inner taillight, and remove any remaining gasket material/adhesive.

NOTE

Do not use commercial adhesive removing chemicals, they could damage the plastic light body.

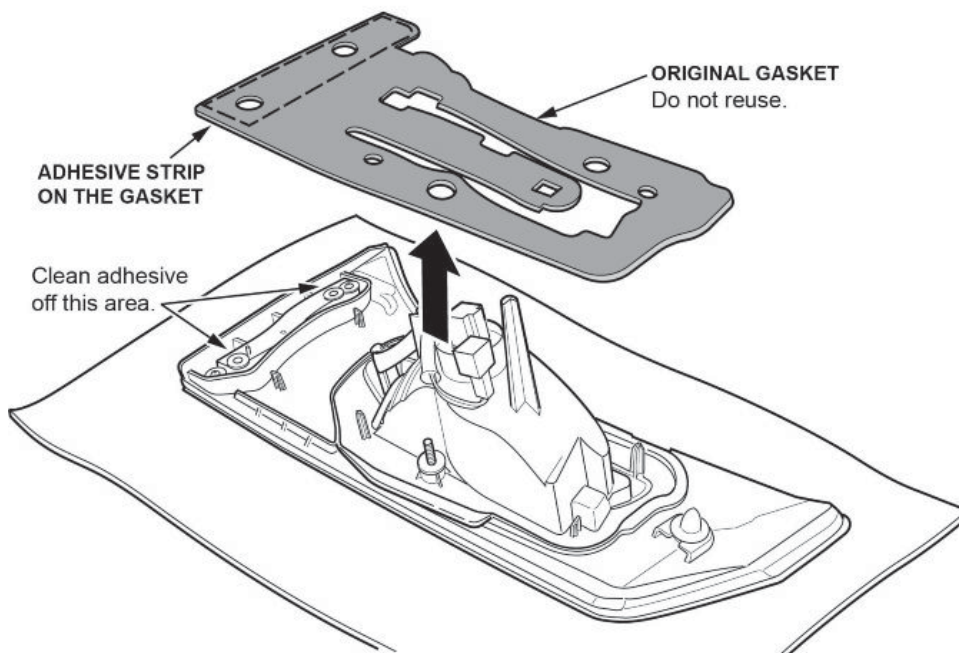

10. Hold the inner taillight upright, and check for trapped water.

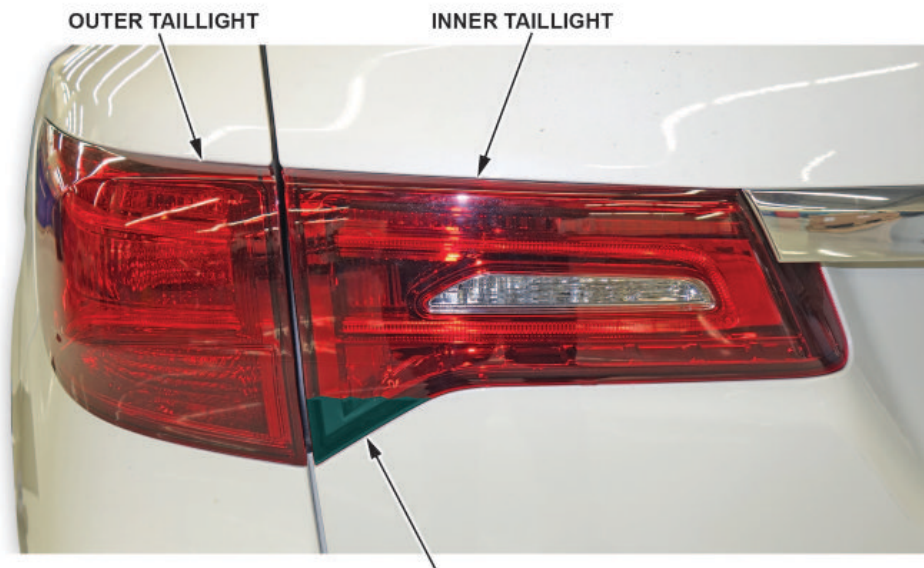

WATER TRAPPED IN INNER TAILLIGHT

If there is trapped water, remove the top screw and turn the light upside down to drain it. Then, install the screw.

NOTE

Remove as much water as possible, any remaining moisture will eventually evaporate.

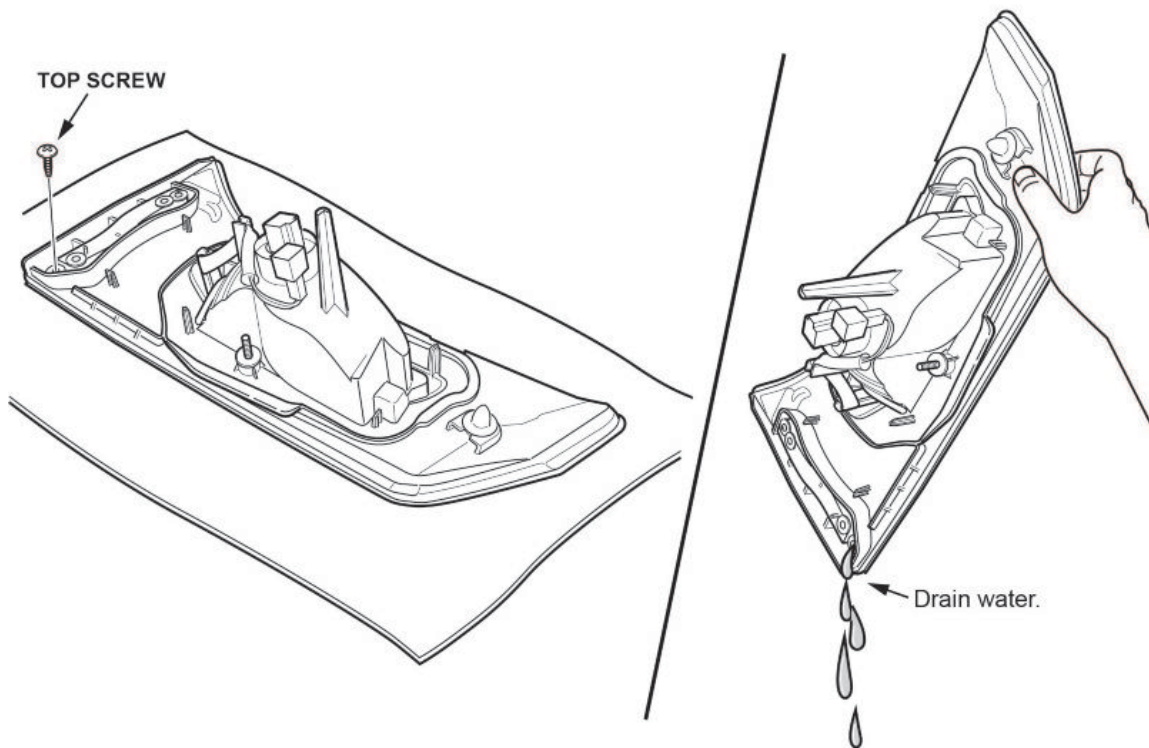

11. Install the correct cutting guide tool (left side or right side) with the part number and cutting direction arrow facing up. Line up the pin and the screw, install the self-leveling washers and nut (included in the repair kit), and torque it to **4.4 N-m (3.2 lb-ft)**.

NOTE

Do not overtighten the nut, this will cause the stud to pull out of the inner taillight.

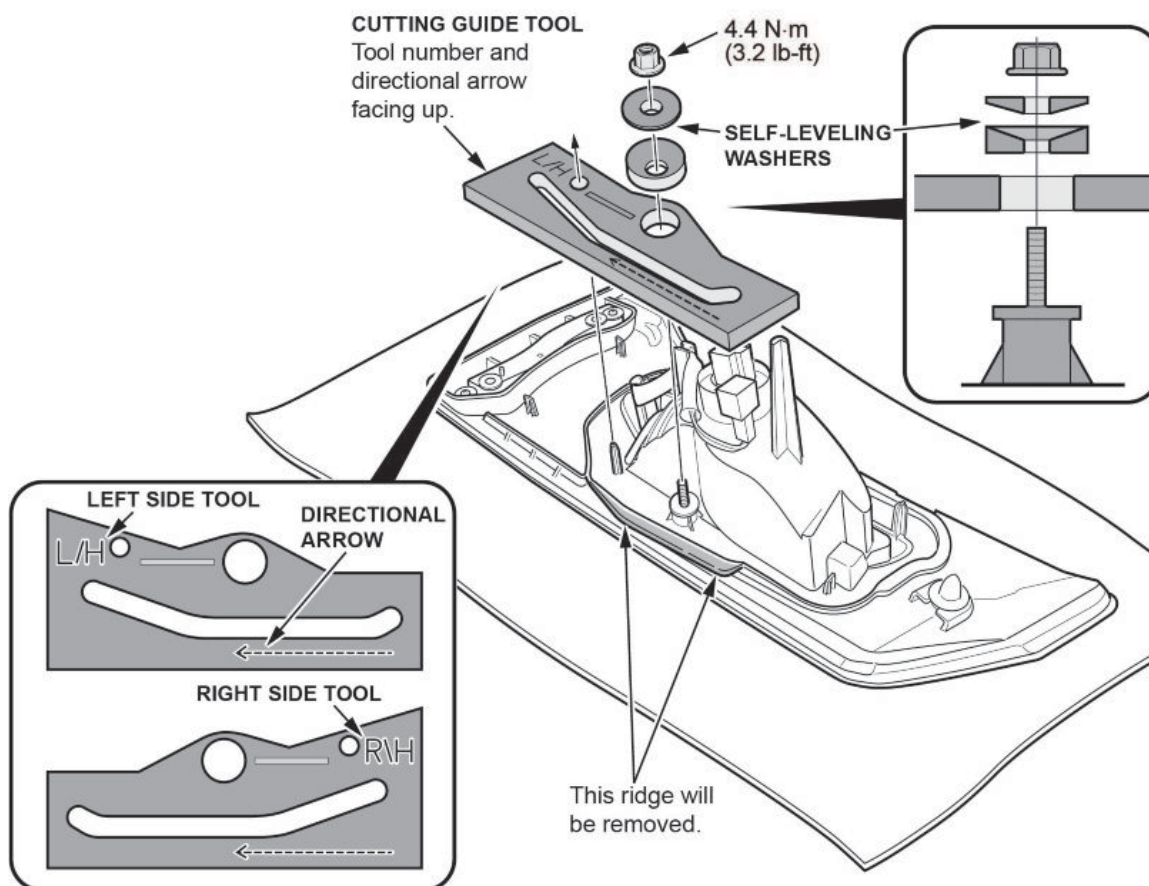

12. Using the flush cut bit attached to a commercially available right angle grinder or similar tool, remove the excess material from the inner taillight housing. Make sure the cutter depth is set to **6 mm**. If needed, loosen the set screw and adjust the height and tighten.

NOTE

Not all of the ridge will be removed, a very small portion should remain.

⚠ CAUTION

Make sure to wear eye protection and stay away from any flammable materials. They can ignite from the sparks produced from grinding.

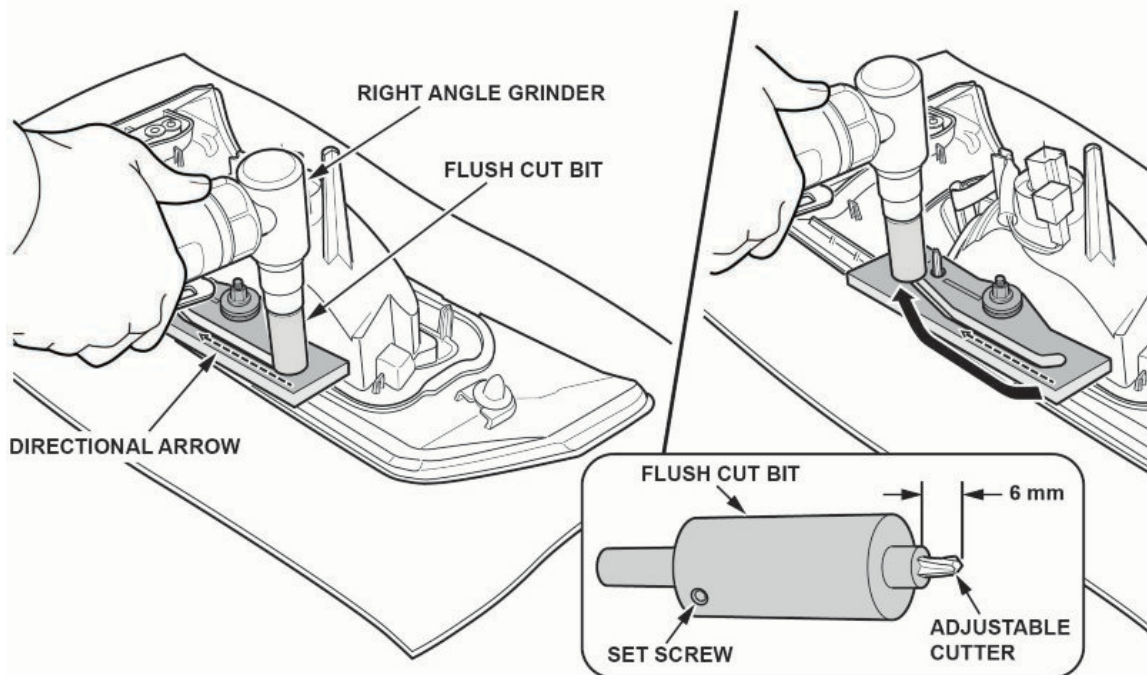

13. Remove the cutting tool, and clean off any debris.

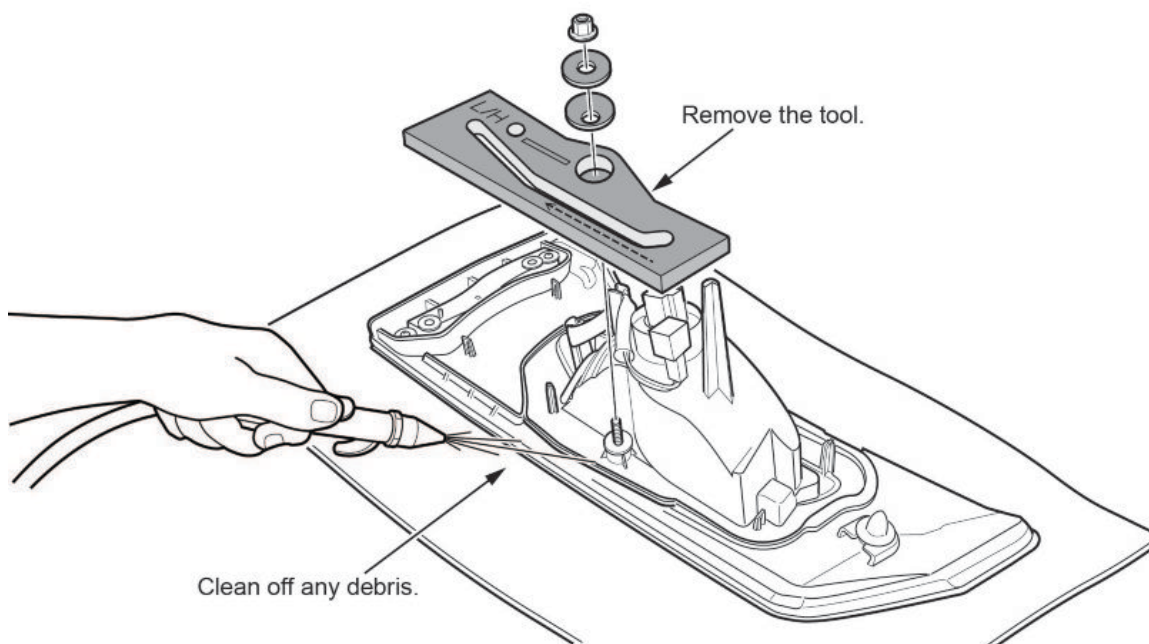

14. Clean inner taillight mating surface with isopropyl alcohol, and install the new light gasket. Remove the adhesive tape backing, and attach it to the taillight.

NOTE

The gaskets are marked **L** for left and **R** for right. Make sure to use the correct side.

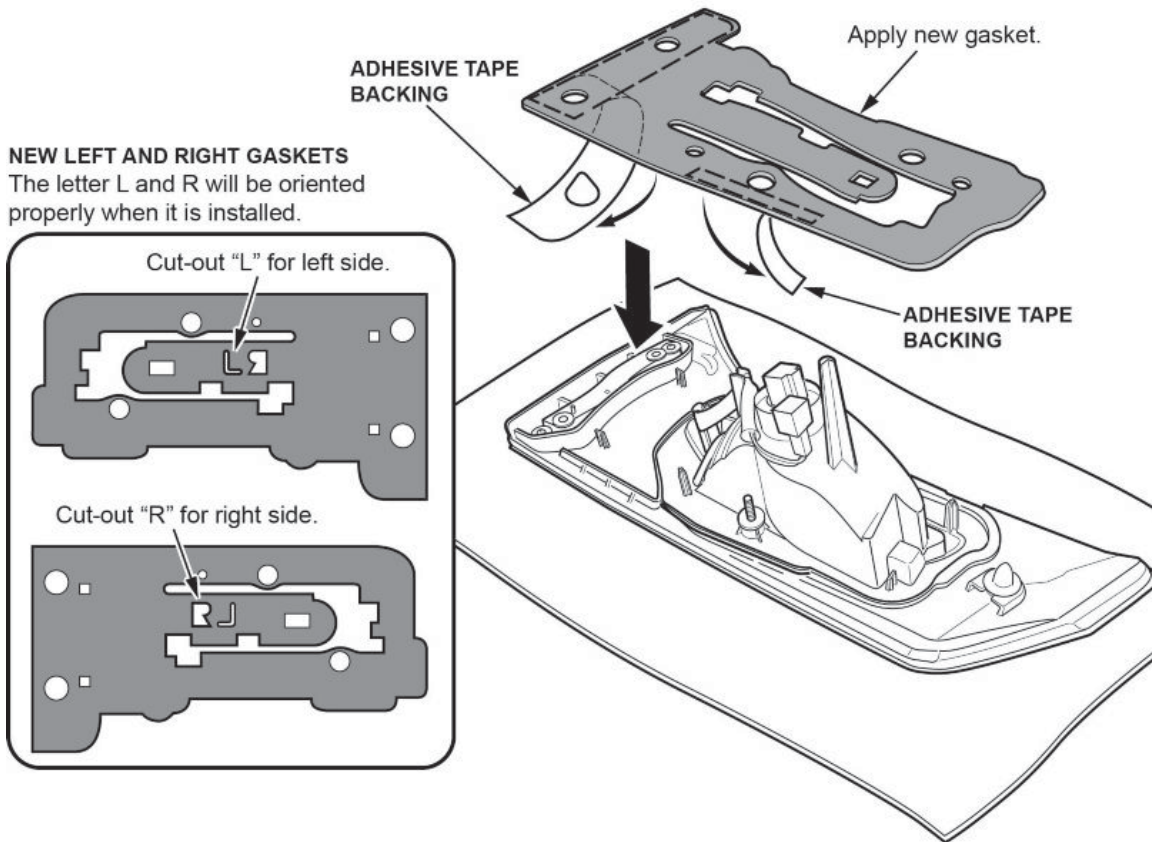

15. Repeat steps 7 thru 14, and modify the second inner taillight.
16. Install the inner taillights, and torque the nuts and bolts to **4.4 N-m (3.2 lb-ft)**.

NOTE

Make sure the gasket is properly attached to the inner taillight.

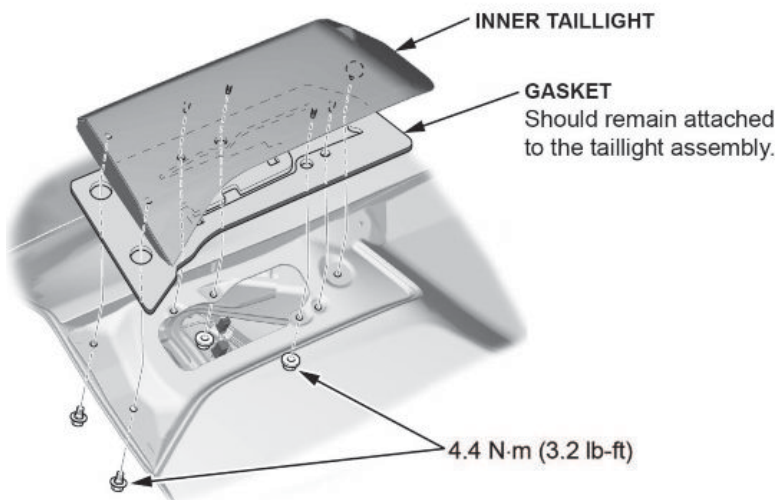

17. Install the rear license plate trim. Make sure the grommets are attached to the studs and clips, then connect the connector, and torque the nuts to **4.9 N·m (3.6 lb-ft)**.

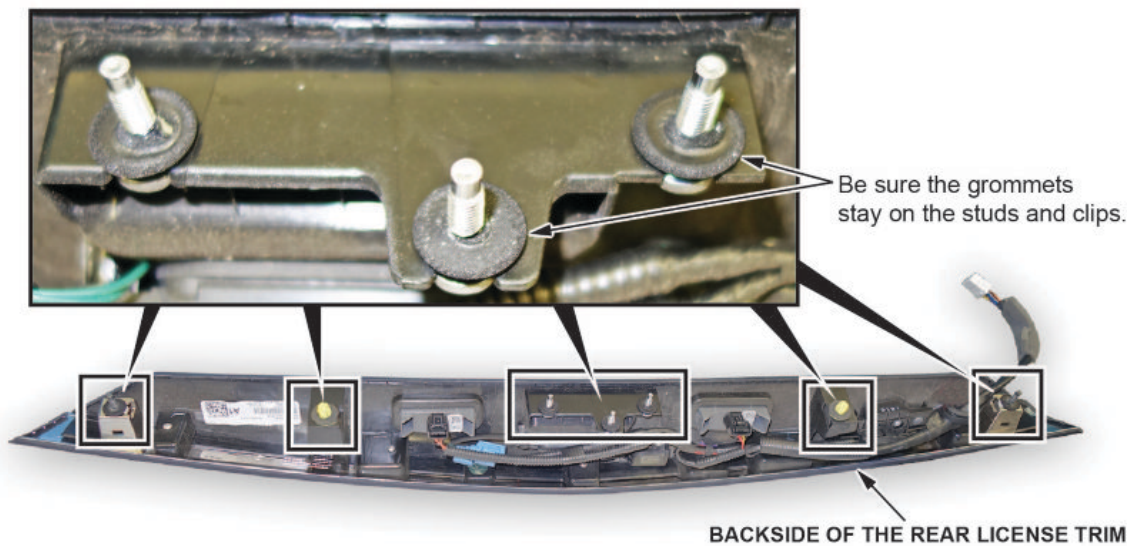

INSIDE THE TAILGATE

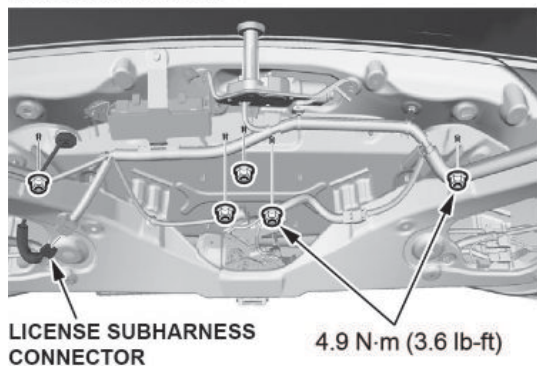

OUTSIDE THE TAILGATE

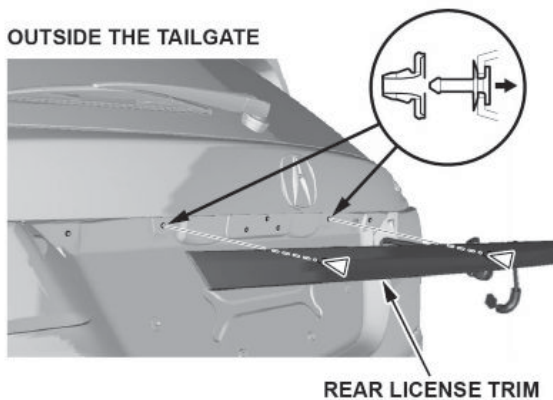

18. Install and route the new inner taillight sub harness (included in the service kit) to the existing tailgate harness as shown.

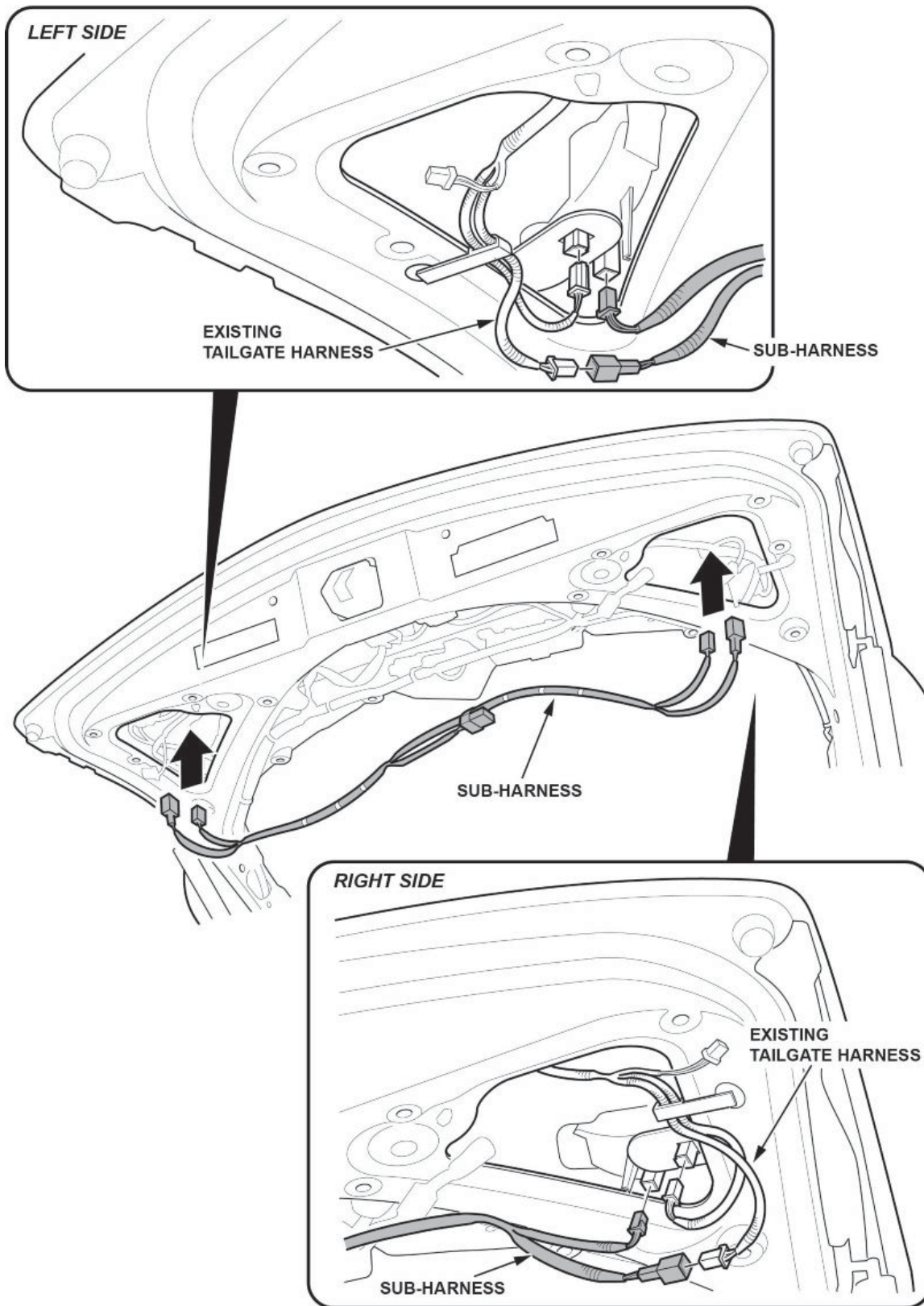

19. Secure the new inner taillight sub harness. Use the supplied wire ties on each of the white pieces of tape found on the new harness, starting from the center and moving out toward the connectors as shown.

NOTE

Trim any excess from the wire ties.

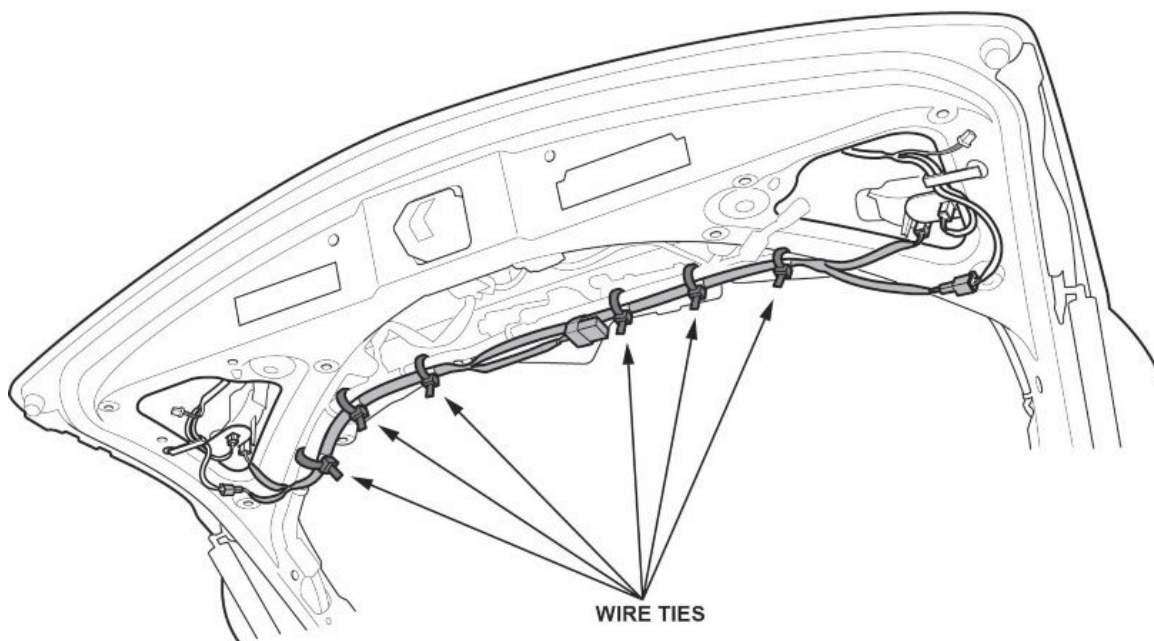

20. Cut two pieces of the foam tape supplied in service kit as shown.

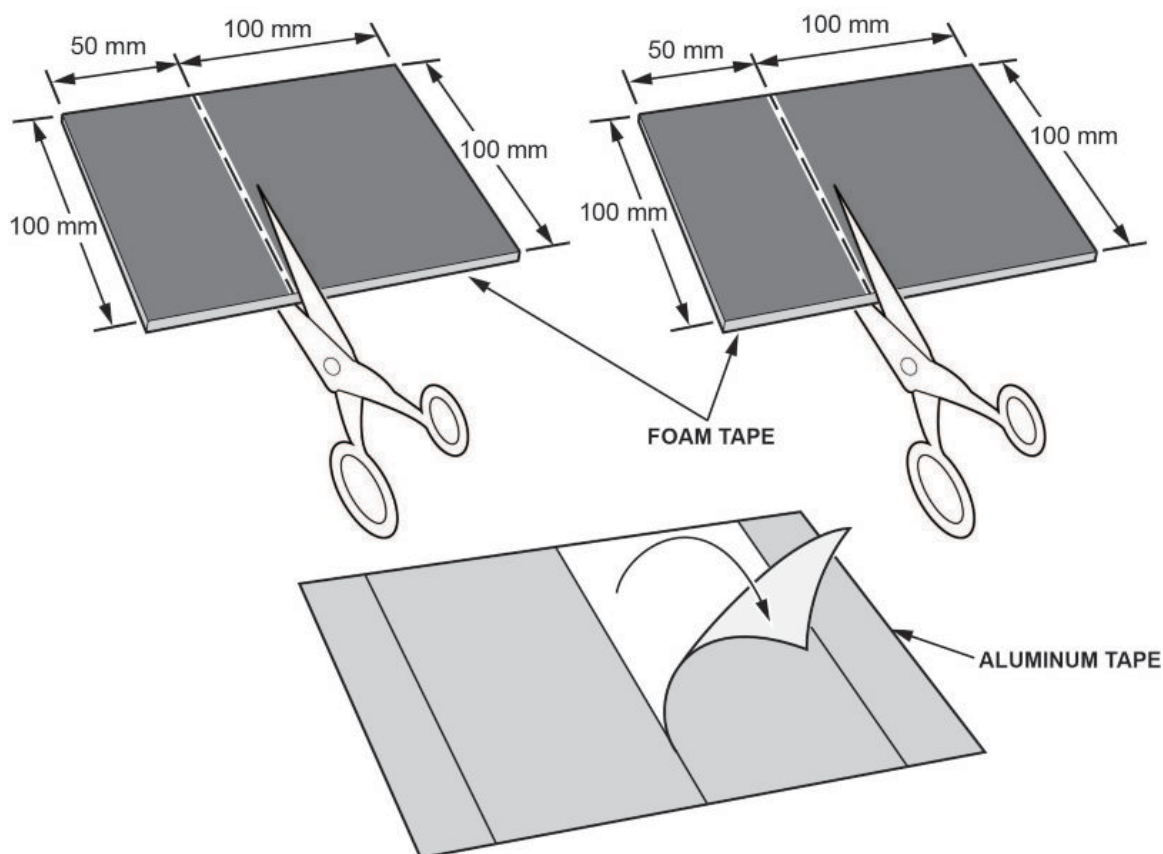

21. Clean the areas shown below with isopropyl alcohol, and attach the foam tape pieces. Then, secure the harness and connectors to the body with aluminum tape as shown.

NOTE

To prevent water intrusion, make sure the foam tape covers the entire connector. The aluminum tape should wrap around the foam wrapped connector to the back side of the metal, this will prevent rattles.

LEFT SIDE

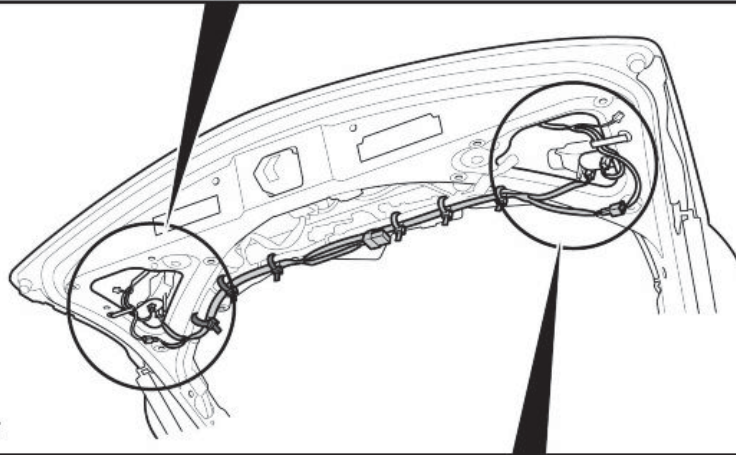
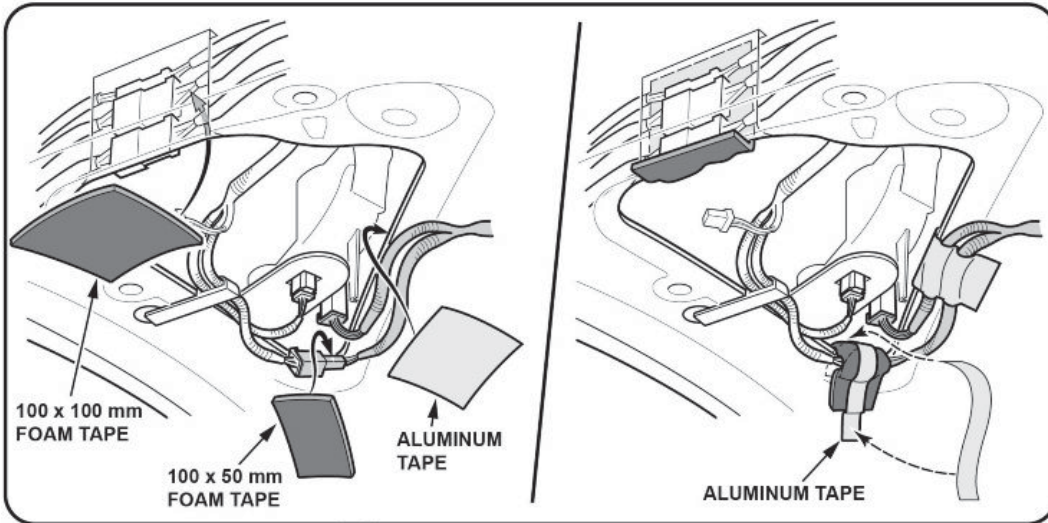

RIGHT SIDE

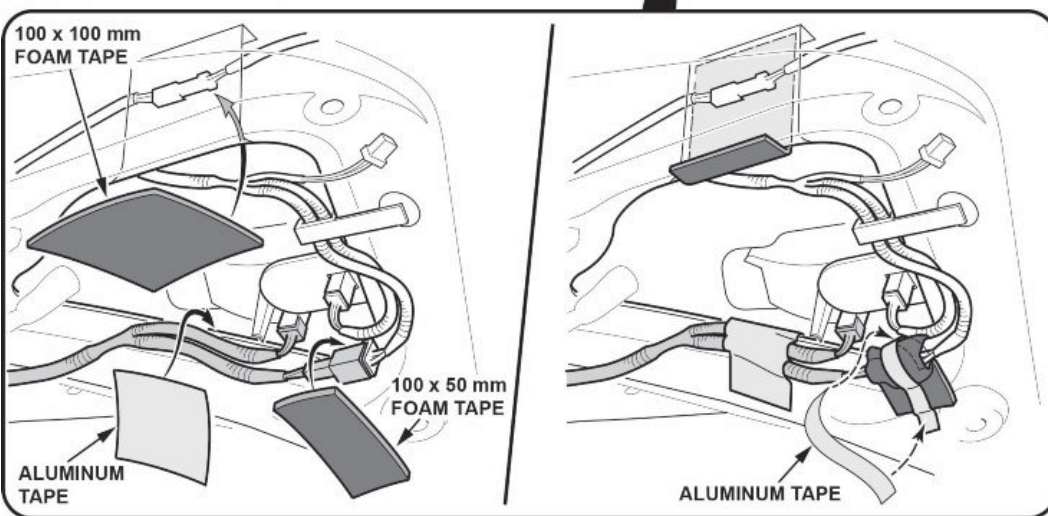

22. Make sure all of the taillights come on. If any of them do not come on, check all of the connections and the small light fuse again.

23. Install the tailgate trim and any other removed parts in the reverse order of removal.

REPAIR PROCEDURE B (REPLACE BOTH INNER TAILLIGHTS)

1. Open the tailgate.

NOTE

Manually open and close the tailgate. Do not use the power tailgate function (if equipped) during the repair to avoid damaging the tailgate support struts.

2. Remove the tailgate upper trim panel, then remove the side trim panels.

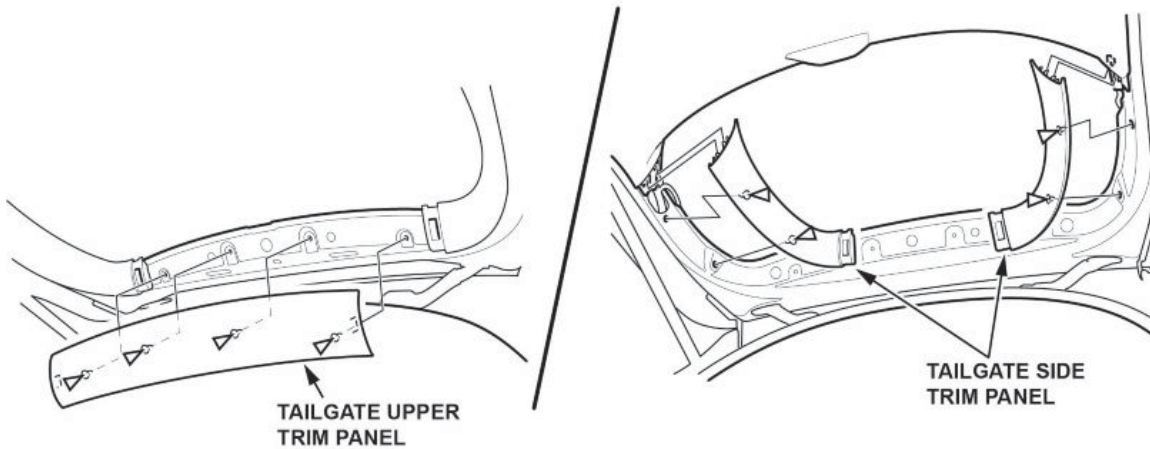

3. Remove the pull pocket, and disconnect the power tailgate switch connector.

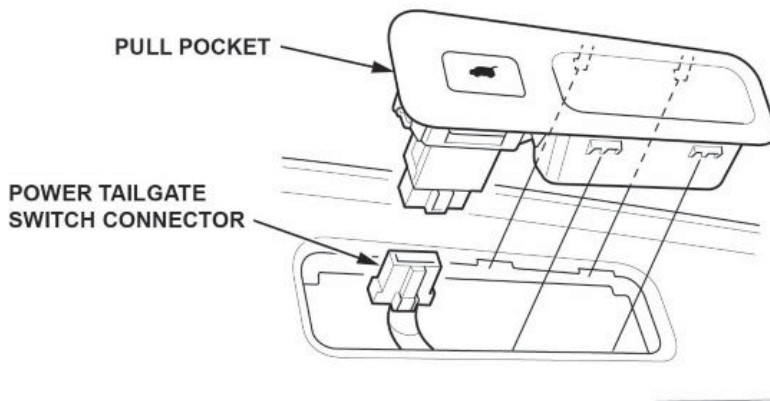

4. Remove the tailgate lower trim panel, then disconnect the tailgate light connectors.

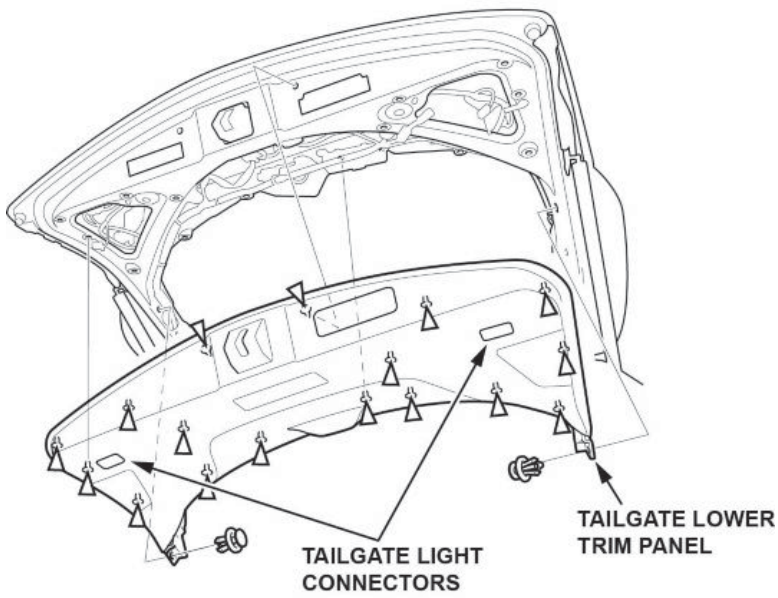

5. Disconnect the license sub harness connector, remove the five nuts, release the pins from the clips, then remove the rear license plate trim.

INSIDE THE TAILGATE

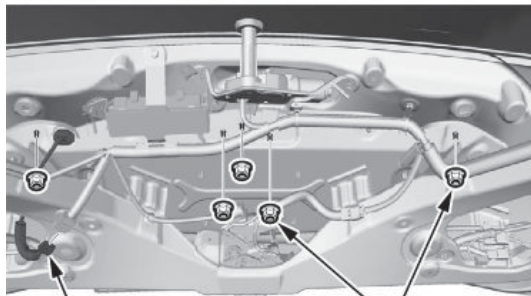

LICENSE SUBHARNESS CONNECTOR

4.9 N-m (3.6 lb-ft)

OUTSIDE THE TAILGATE

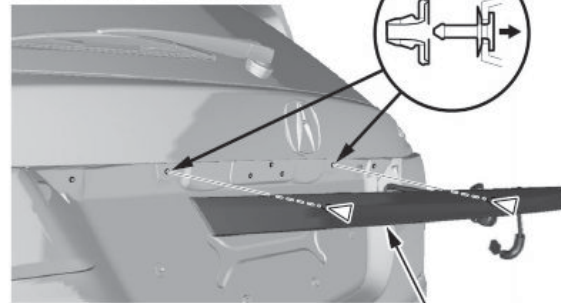

REAR LICENSE TRIM

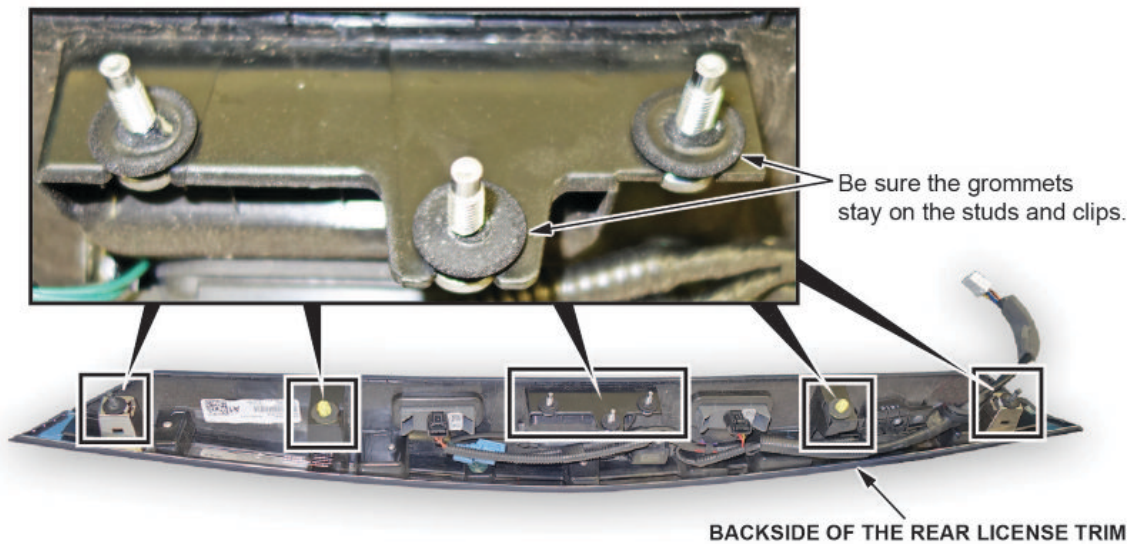

BACKSIDE OF THE REAR LICENSE TRIM

6. Disconnect both inner taillight connectors.

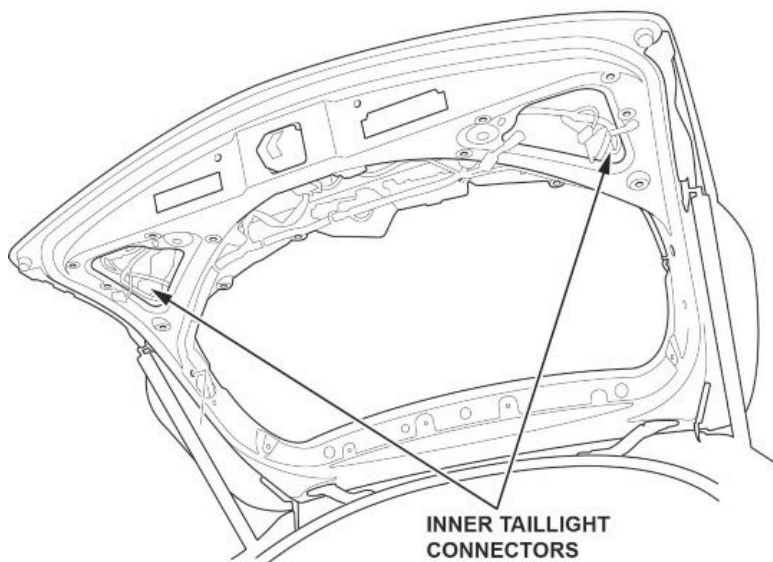

7. Remove the two bolts and two nuts behind each inner taillight, then replace both inner taillights and torque the nuts and bolts to **4.4 N-m (3.2 lb-ft)**

NOTE

Be sure to completely remove the old inner taillight gasket. The new inner taillight will come with a new gasket installed.

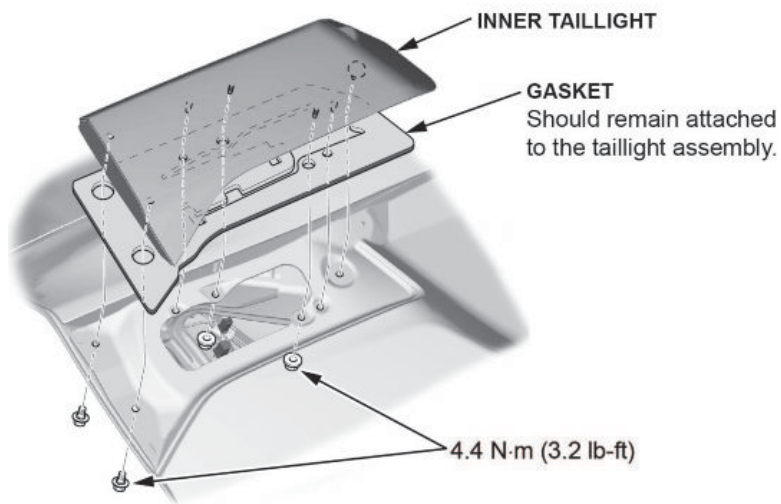

8. Connect the inner taillight connectors.

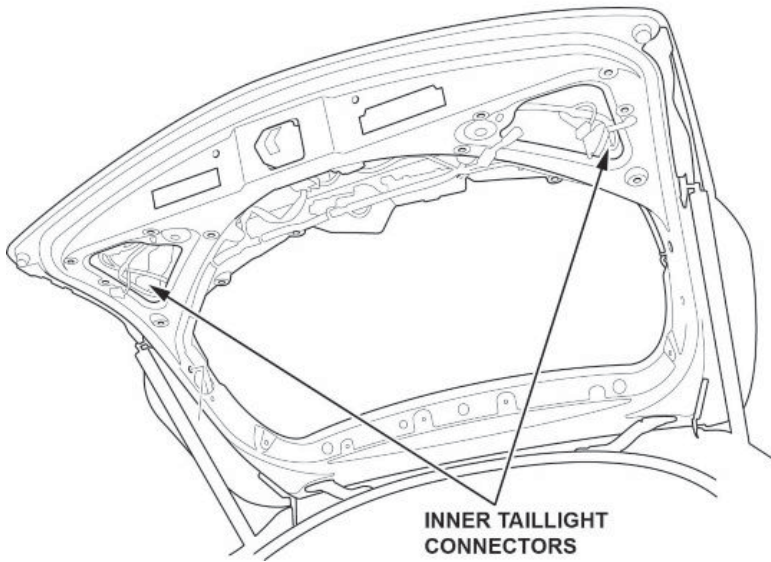

9. Install the rear license trim. Make sure the grommets are attached to the studs and clips, then connect the connector, and torque the nuts to **4.9 N-m (3.6 lb-ft)**.

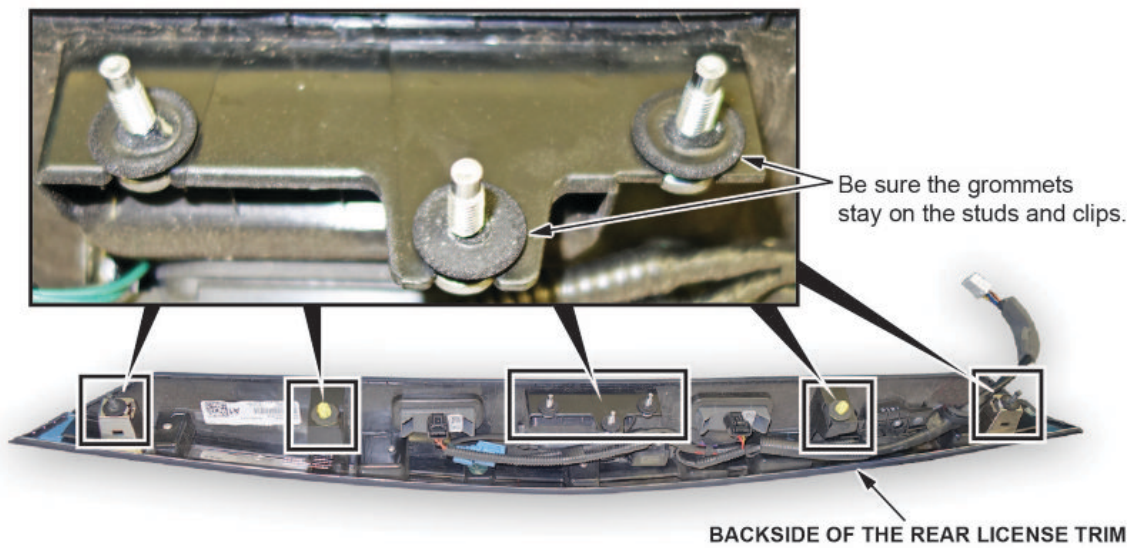

INSIDE THE TAILGATE

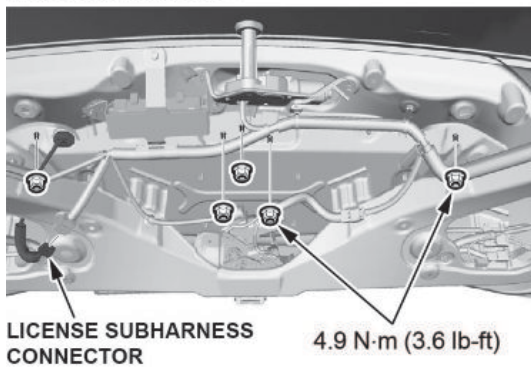

OUTSIDE THE TAILGATE

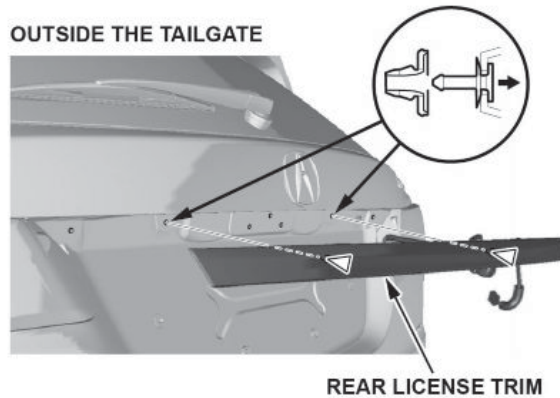

10. Make sure all of the taillights come on. If any of them do not, check all of the connections and the small light fuse again.
11. Install the tailgate trim and any other removed parts in the reverse order of removal.

END