



SAFETY BULLETIN

Release Date: April 30, 2018

SLI

Communication #: T-18-01

Model Year(s): 2015-2019

— Confidential and Proprietary —

VERSION: R03 (March 7, 2019)

Additional units added to the affected population, including some 2019 models. Reference Unit Inquiry or the Bulletin lookup tool to ensure all affected units are identified and repaired per this Safety Bulletin.

IMPORTANT STOP SALE SAFETY NOTICE!

Stop selling affected vehicles immediately until the repair procedure has been completed on affected units at your dealership. Federal law prohibits the sale of products subject to a recall. Selling such products could subject the seller to substantial penalties.

IMPORTANT

If you are working with a printed copy, please verify you have the most current version of these instructions.

SUBJECT: SEAT BASE FRAME INSPECTION / REPLACEMENT

PURPOSE

A small number of Slingshot vehicles may have been manufactured with defective seat base frames, including one or both of the following issues:

- Driver-side and passenger-side seatbase frames may have been improperly manufactured, lacking one or more welds. The absence of one or more welds can compromise the strength of the mount and cause the seatback frame and/or seatbelt buckle to separate from the seat base frame, increasing the risk of injury during a crash.
- Driver-side seatbase frames may contain a seat slider defect which may cause the seat to slide without driver input during acceleration or braking events, increasing the risk of a crash.

To address this concern, dealers should follow the inspection process outlined in Part A to ensure all seatbase frame welds are present. Additionally, for driver-side seats, complete a driver seat slider test to ensure the mechanism is engaging properly. If a defect is found during the inspection, replace the seat base as directed in the instructions of this bulletin.

NOTE

Only a small number of vehicles will exhibit the manufacturing defects described above and require seat base replacement. The required inspection outlined below will resolve the majority of the affected vehicle population without requiring seat base replacement.

AFFECTED MODELS

MODEL YEAR	MODELS	VEHICLE IDENTIFICATION NUMBER RANGE
2015–2019	Slingshot / SL / SLR / GT	Reference Unit Inquiry on the dealer website or the Service Bulletin list on the STOP site to lookup affected VINs.

CUSTOMER NOTIFICATION

Dealers are required to review their sales records and make arrangements with customers for Safety Bulletin completion. In addition to consumer units, dealers are required to correct any affected units in their inventory. Polaris will be mailing a Safety Alert notification letter to consumers affected by this Safety Bulletin in the United States and Canada.

WARRANTY CLAIM PARTS INFORMATION

Bulletin/Advisory parts are excluded from the standard RMA policy and cannot be returned. An Initial Recommended Order Quantity has not been provided for this bulletin. Use Quantity Ordered to Date and the Open VIN List from the STOP site to determine an order amount that's right for your dealership. For more details, refer to University of Polaris training course "Polaris Item Availability and Daily Ordering" and click on "Bulletin Ordering Training".

NOTE

Parts are needed only if the inspection reveals a failed driver-side seat base slider test or missing welds on either the driver or passenger-side seat bases.

DRIVER-SIDE AND PASSENGER-SIDE SEAT BASE FRAME INSPECTION

Bulletin #	T-18-01-A
Claim Type	SB (Safety Bulletin)
Labor Allowance	0.4 hours (24 minutes)
Part Number / Description	0000541 (QTY 1) Bulletin Misc Labor
Parts Availability	NA
University of Polaris Video Training Required	YES ¹

¹Polaris requires one person from a dealership to be certified before parts ordering may occur and two people from a dealership to be certified before warranty claims may be processed.

INSPECT DRIVER AND PASSENGER-SIDE SEAT BASE FRAMES REPLACE DRIVER-SIDE SEAT BASE FRAME	
Bulletin #	T-18-01-B
Claim Type	SB (Safety Bulletin)
Labor Allowance	0.9 hours (54 minutes)
Part Number / Description	2207822 (QTY 1) KIT, Driver-Side Seat Base Frame
Parts Availability	Available to order
University of Polaris Video Training Required	YES ¹

¹Polaris requires one person from a dealership to be certified before parts ordering may occur and two people from a dealership to be certified before warranty claims may be processed.

INSPECT DRIVER AND PASSENGER-SIDE SEAT BASE FRAMES REPLACE PASSENGER-SIDE SEAT BASE FRAME	
Bulletin #	T-18-01-C
Claim Type	SB (Safety Bulletin)
Labor Allowance	1.2 hours (72 minutes)
Part Number / Description	2207823 (QTY 1) KIT, Passenger-Side Seat Base Frame
Parts Availability	Available to order
University of Polaris Video Training Required	YES ¹

¹Polaris requires one person from a dealership to be certified before parts ordering may occur and two people from a dealership to be certified before warranty claims may be processed.

DRIVER-SIDE AND PASSENGER-SIDE SEAT BASE INSPECTION AND REPLACEMENT	
Bulletin #	T-18-01-D
Claim Type	SB (Safety Bulletin)
Labor Allowance	1.7 hours (102 minutes)
Part Number / Description	2207822 (QTY 1) KIT, Driver-Side Seat Base Frame 2207823 (QTY 1) KIT, Passenger-Side Seat Base Frame
Parts Availability	Available to order
University of Polaris Video Training Required	YES ¹

¹Polaris requires one person from a dealership to be certified before parts ordering may occur and two people from a dealership to be certified before warranty claims may be processed.

ACCESSORY REMOVE & REPAIR LABOR

Polaris will cover labor for the removal and installation of accessories required to complete the bulletin work. Follow the steps below to obtain reimbursement.

For accessory removal and installation up to 30 minutes of labor:

Enter the actual labor time for the removal and installation into the Accessory R&R Min Field on the bulletin claim.

For accessory removal and installation over 30 minutes of labor:

1. Start a new Ask Polaris Case, Service & Warranty Question > Authorization: Non-Cosmetic & Polaris ESC or Authorization: Out of Warranty.
2. Enter your contact information and VIN, along with miles and hours into the applicable fields.
3. Enter T-18-01 in the CONCERN and CAUSE fields. In the CORRECTION field, enter "ACCESSORY REMOVAL AND INSTALLATION".
4. Enter warranty fail codes 110/233/158.
5. Add part 0000541, quantity 1.
6. Attach photos of the vehicle and accessories sufficient to support the labor time requested.
7. Submit the case to Polaris.

INVENTORY / STOCK PART CLAIMS

Dealers should review their service parts inventory and ensure the following service parts are **NOT** used for any repairs. Return all parts to Polaris:

- 2686180 - Driver-Side Seat Base Frame
- 1023138 - Driver-Side Seat Base Frame
- 1021240 - Passenger-Side Seat Base Frame

NOTE

To remove these service parts from circulation, file a parts stock claim as directed below.

Use the following process for filing a PART STOCK warranty claim for any of the parts listed above.

1. Start a new Part Stock warranty claim.
2. Select Product Line: SLI
3. Enter today's date into the Date Failed and Date Repair information fields
4. Enter T-18-01 into the CONCERN field.
5. Enter T-18-01 into the CAUSE field.
6. Enter T-18-01 into the CORRECTION field.
7. Enter the part number and quantity.
8. Enter warranty fail codes: 110/233/158
9. Validate the parts.
10. Save and submit the claim to Polaris.

BULLETIN CONTACT LIST & SCHEDULING TOOL

A scheduling tool is available for dealers to keep a record of customers contacted and scheduled for this bulletin. This optional tool provides visibility for your dealership and will be helpful to track the status of scheduled service. For more information, log in to <http://www.universityofpolaris.com>.

BULLETIN COVERAGE PERIOD

Coverage for this bulletin will begin on March 27th, 2018. This bulletin has no expiration date.

UNIVERSITY OF POLARIS TRAINING REQUIREMENT

Each member of your service department team must complete the training on University of Polaris prior to completing **ANY** work, or submitting **ANY** warranty claim for this Bulletin. You must complete the entire course on University of Polaris in order to get credit.

www.universityofpolaris.com

PARTS RETURN / DISPOSAL INFORMATION

Under no circumstances shall the parts removed be re-used, sold, or re-purposed for another application. It is your dealership / distributor's responsibility to make sure every part replaced (related to this communication) is taken out of circulation and disposed of properly or returned to Polaris (if required).

FEEDBACK FORM

A feedback form has been created for the technician to provide Polaris with an overall satisfaction rating for the instructions, provide comments on your experience or upload pictures/video from a specific repair. This feedback form is viewable on a mobile device by scanning the QR code or by clicking **HERE** if viewing this document electronically.



T-18-01-A SEAT BASE INSPECTION

TOOLS REQUIRED

- Flashlight
- Mirror

SEAT BASE FRAME WELD INSPECTION

IMPORTANT

Most vehicles affected by this bulletin will be resolved by T-18-01-A.
Seat Base Frame Weld Inspection and Seat Slider Test.

Parts are needed only if the inspection reveals a failed driver-side seat base slider test or missing welds on either the driver or passenger-side seat bases.

- Park vehicle on a flat and level surface. Keep transmission in gear. Set parking brake. Turn key to "OFF" position and remove from vehicle.
- Cover Wing Panel ① Center Console ②, and Speaker Surround ③ with a protective mat to prevent cosmetic damage to panels and painted surfaces.

CAUTION

Remove personal items such as rings, keychains, belts, etc. which may unintentionally damage cosmetic surfaces

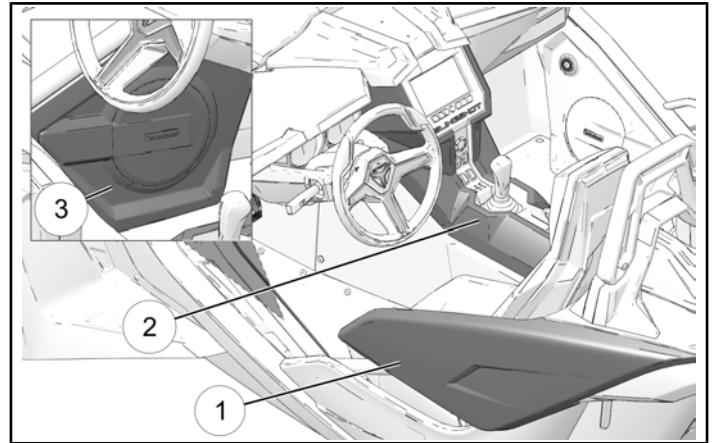

- Inspect for welds along both sides of the seat base as indicated by the arrows.

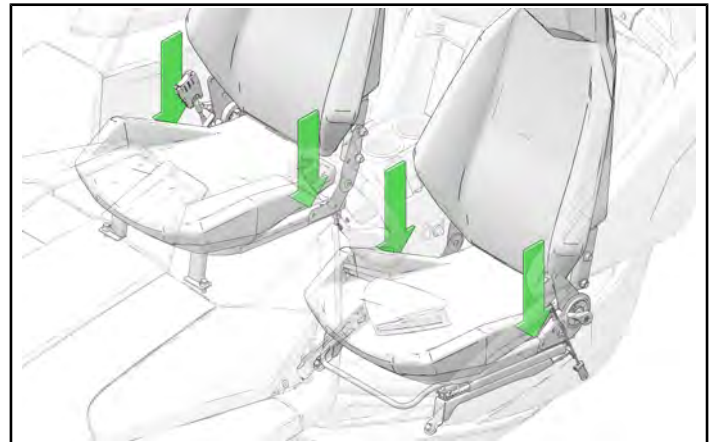

Passenger-Side Seat Base Frame Weld Inspection:

IMPORTANT

Each weld is unique, the length and size of the welds are not critical. If welds are present in the approximate locations specified, then the seat base frame passes inspection.

Visually inspect the passenger-side seat base frame using an inspection mirror and a flashlight at the locations shown below. See next page for examples of good and bad welds with locations matching the callout numbers ① - ④ below.

For additional pictures of good welds [CLICK HERE](#).

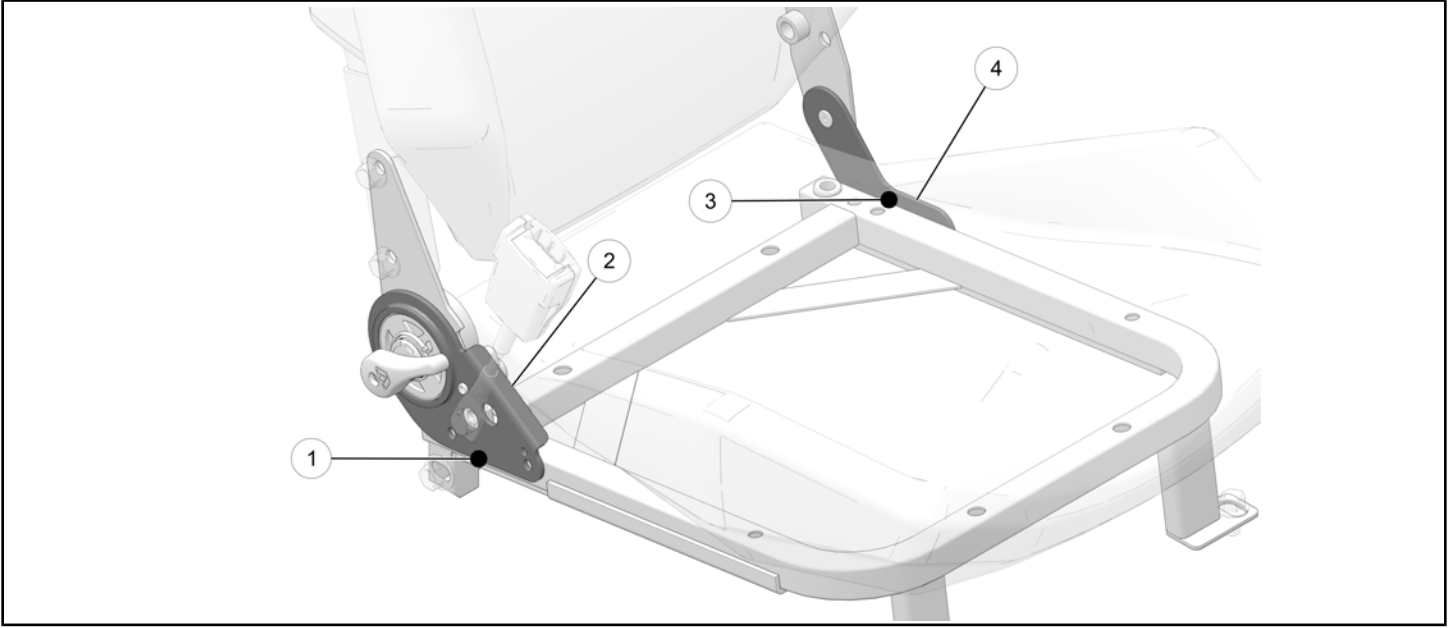

STOP!

Welds must be present at all seat base frame locations. See next page for examples. If welds are missing, the seat MUST BE REPLACED.

To gain access to the weld area, follow the steps below.

- A** - Remove seat from vehicle. See page 19 for detailed seat removal instructions.
- B** - To gain access to welds, remove the seat base bottom cushion.

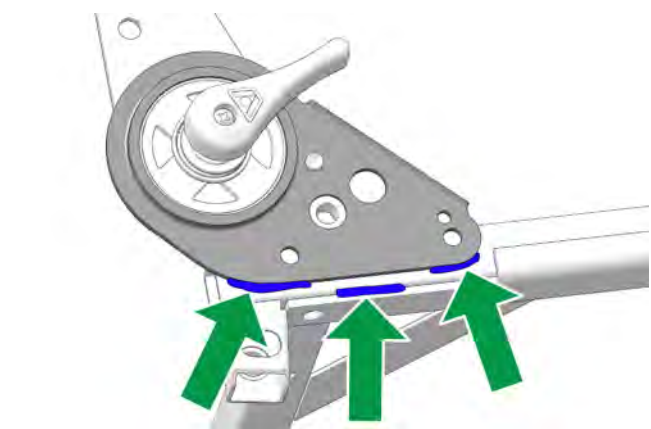
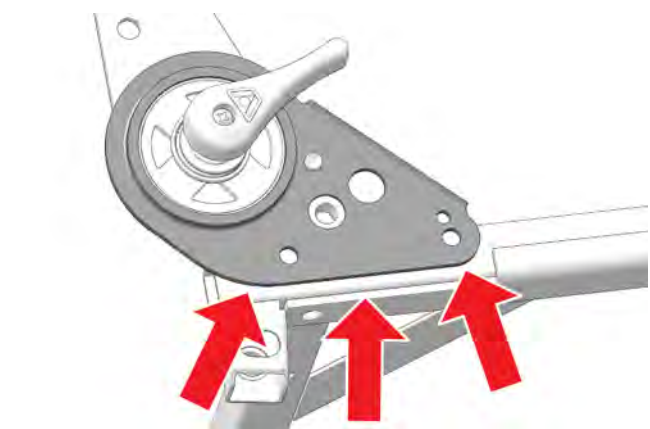
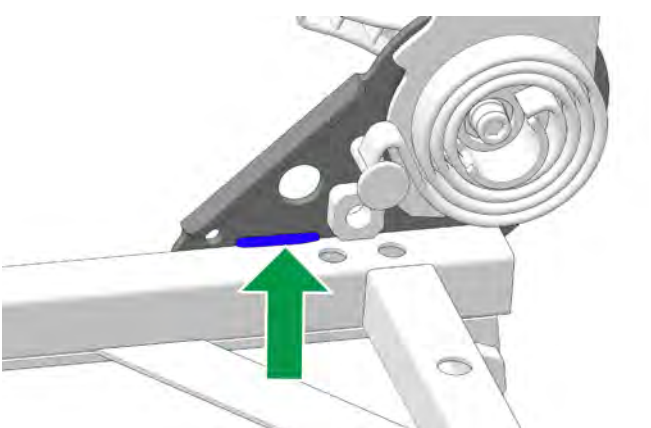
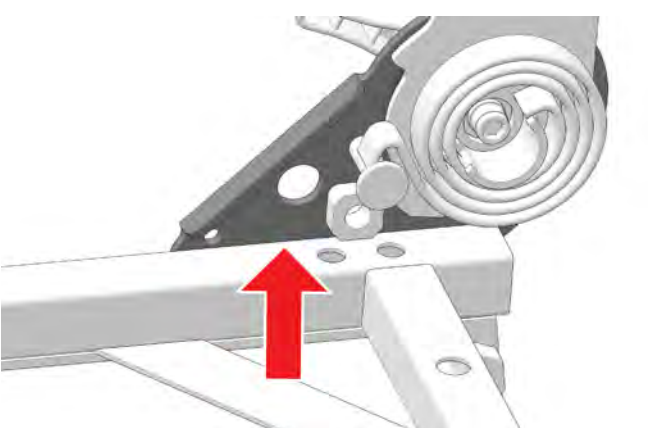
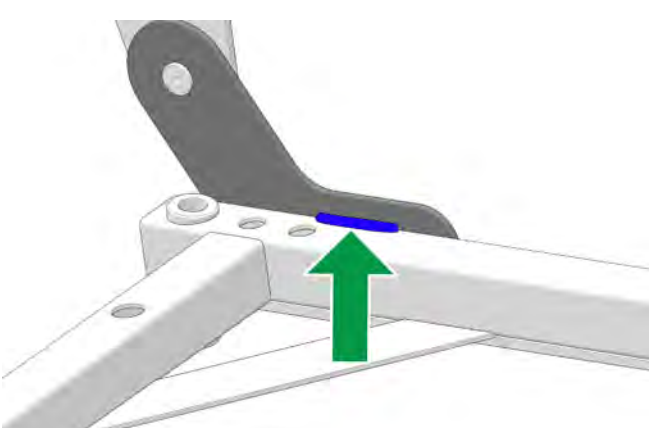
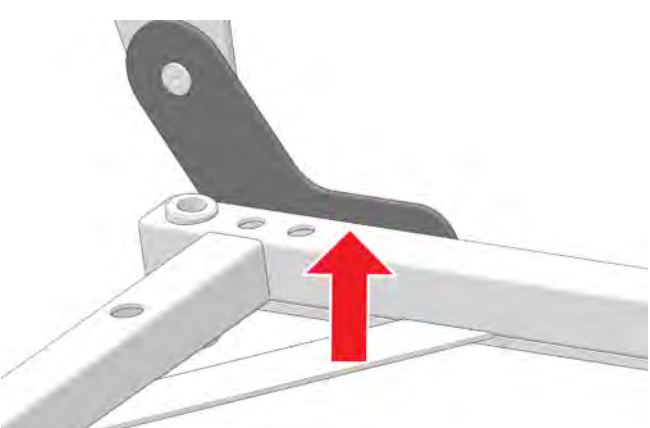
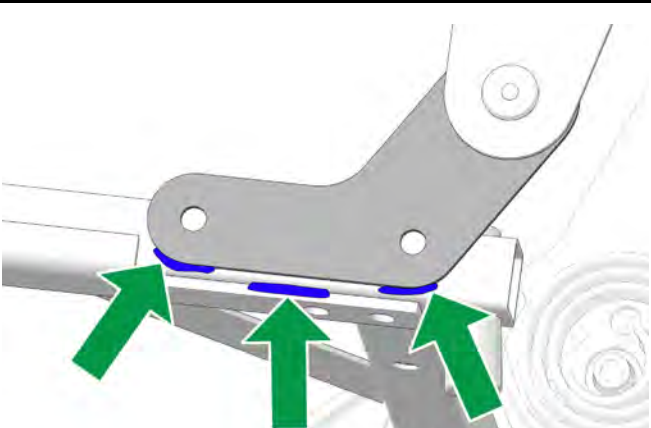
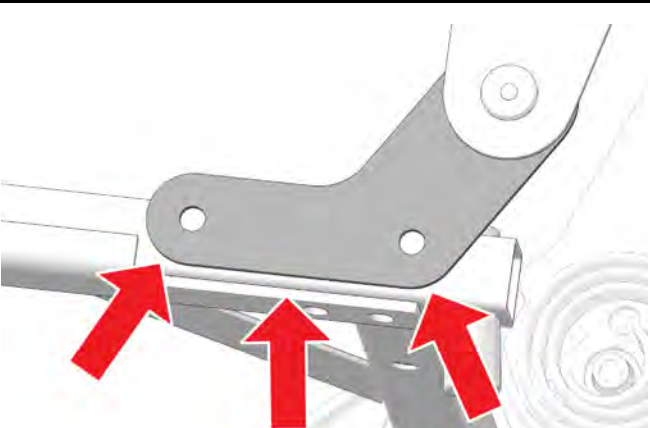
#	EXAMPLES OF GOOD WELDS	EXAMPLES OF MISSING WELDS
①	 <p>Diagram 1 shows a close-up of a metal bracket attached to a frame. Three green arrows point to three distinct, continuous weld lines along the bottom edge of the bracket, indicating good welding.</p>	 <p>Diagram 1 shows the same bracket and frame. Three red arrows point to gaps between the bracket and the frame, indicating missing welds.</p>
②	 <p>Diagram 2 shows a different view of the bracket and frame. A single green arrow points to a continuous weld line, indicating a good weld.</p>	 <p>Diagram 2 shows the same view. A single red arrow points to a gap between the bracket and the frame, indicating a missing weld.</p>
③	 <p>Diagram 3 shows a close-up of the bracket's attachment point. A single green arrow points to a continuous weld line, indicating a good weld.</p>	 <p>Diagram 3 shows the same view. A single red arrow points to a gap between the bracket and the frame, indicating a missing weld.</p>
④	 <p>Diagram 4 shows a close-up of the bracket's attachment point. Three green arrows point to three distinct, continuous weld lines, indicating good welding.</p>	 <p>Diagram 4 shows the same view. Three red arrows point to gaps between the bracket and the frame, indicating missing welds.</p>

The information contained within this document is confidential and protected by U.S. and international copyright laws, and is the property of Polaris Industries. This document is provided for the sole use of authorized Polaris dealers and distributors. This document is not to be distributed, duplicated, or copied, digitally or otherwise, without the written consent of Polaris Industries Inc.

Driver-Side Seat Base Frame Weld Inspection:

IMPORTANT

Each weld is unique, the length and size of the welds are not critical. If welds are present in the approximate locations specified, then the seat base frame passes inspection.

Visually inspect the driver-side seat base frame using an inspection mirror and a flashlight at the locations shown below. See next page for examples of good and bad welds with locations matching the callout numbers ① - ④ below.

For additional pictures of good welds [CLICK HERE](#).

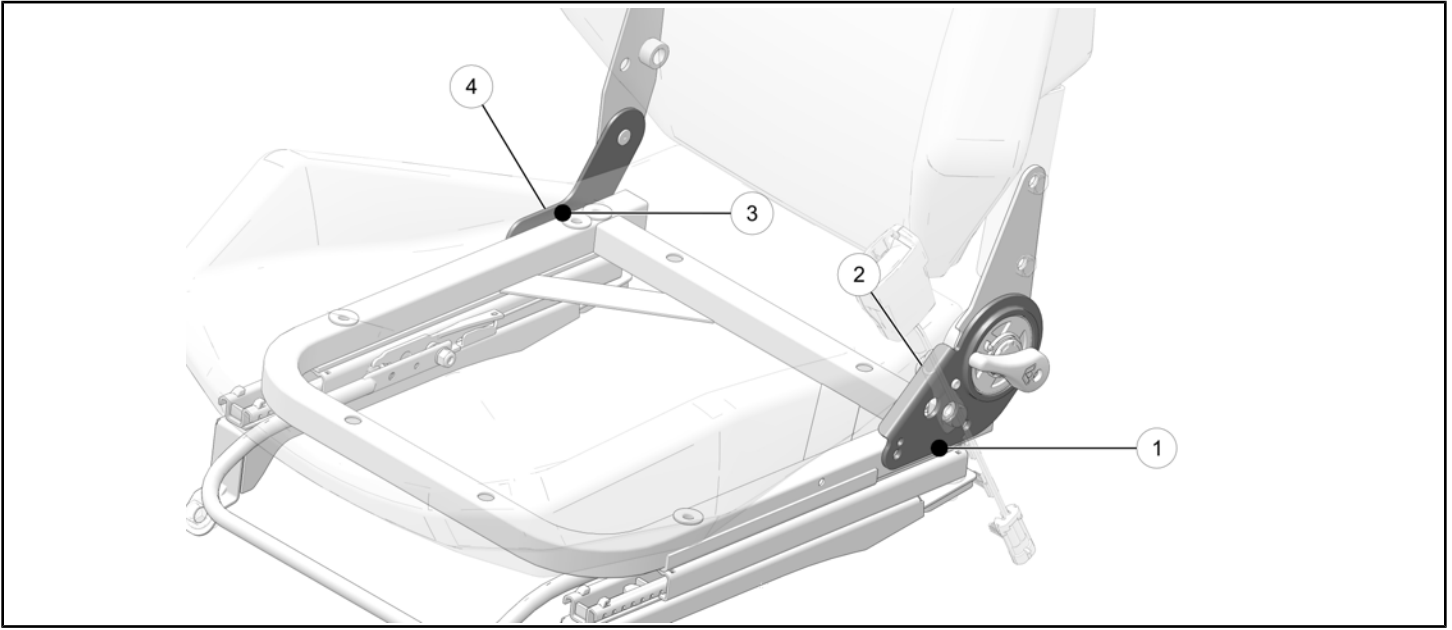

- If all welds are present on the driver-side seat base frame, perform the **Seat Slider Test** on page 11.

STOP!

Welds must be present at all seat base frame locations. See next page for examples. If welds are missing, the seat MUST BE REPLACED.

To gain access to the weld area, follow the steps below.

A - Remove seat from vehicle. See page 13 for detailed seat removal instructions.

B - To gain access to welds, remove the seat base bottom cushion.

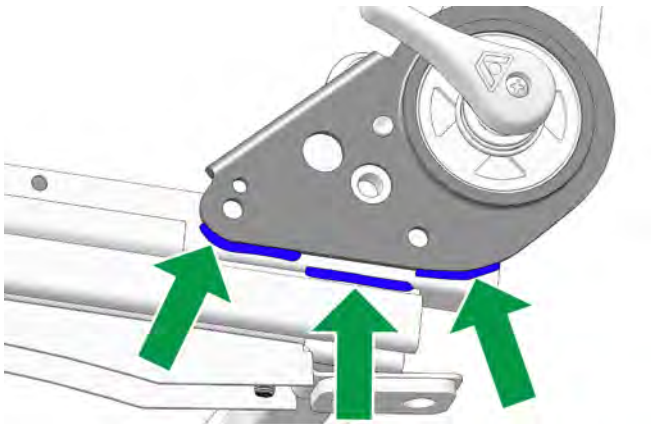
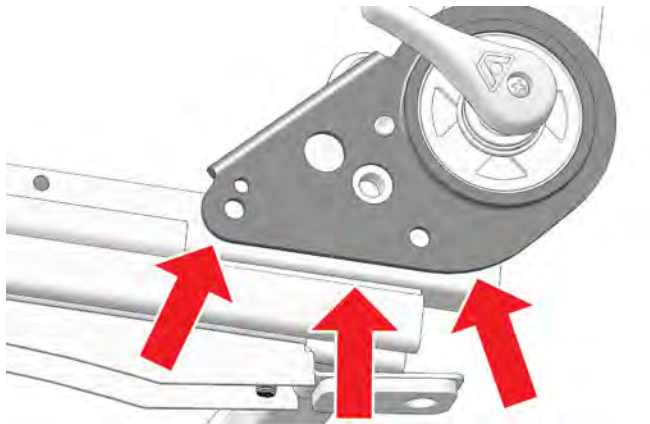
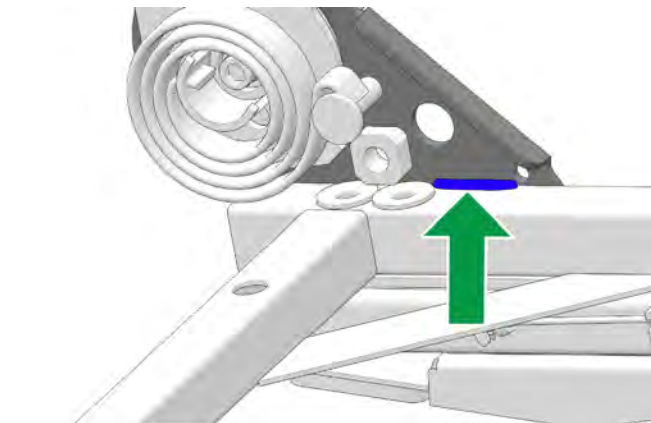
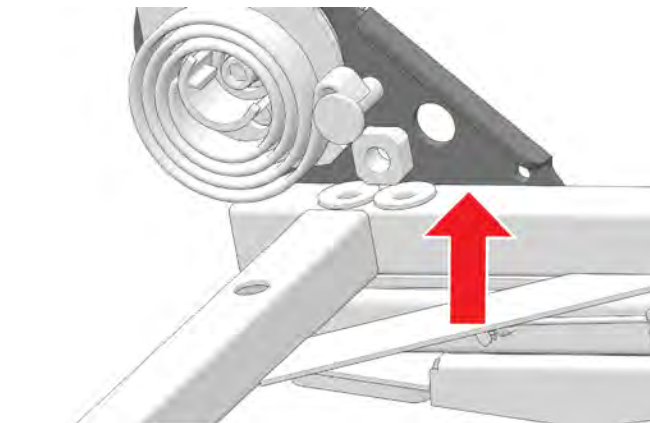
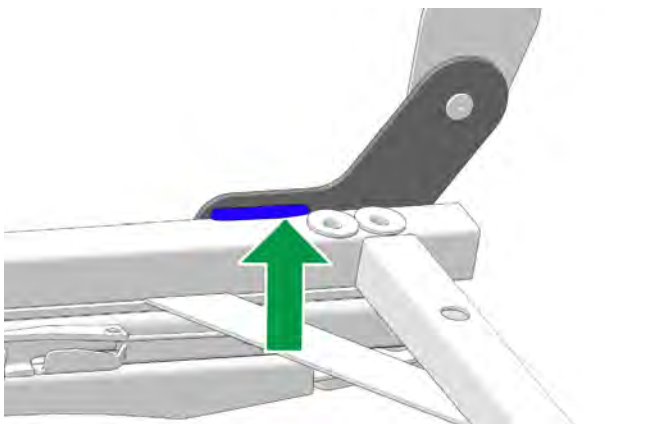
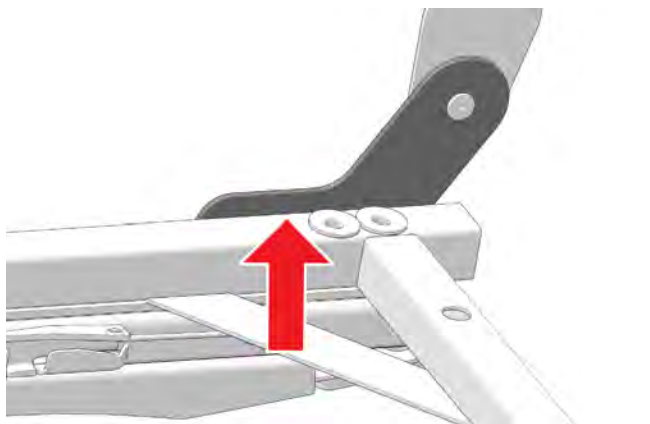
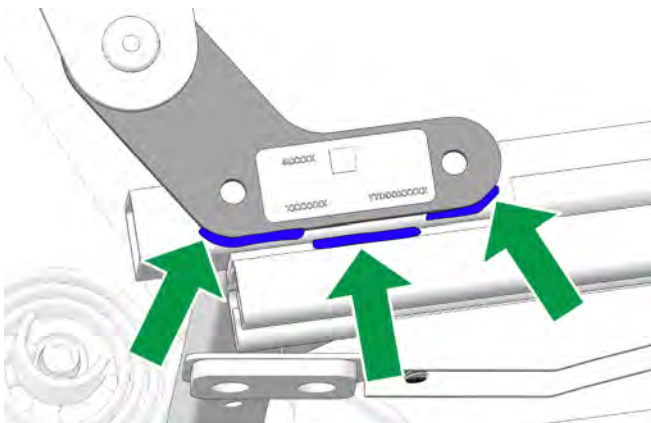
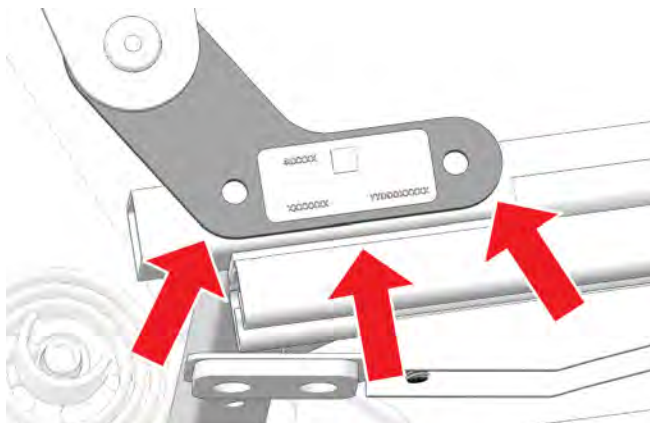
#	EXAMPLES OF GOOD WELDS	EXAMPLES OF MISSING WELDS
①	 <p>Diagram 1 shows a close-up of a metal bracket assembly. Three green arrows point upwards to three distinct blue weld lines that are continuous and well-defined, indicating good welding quality.</p>	 <p>Diagram 1 shows the same metal bracket assembly. Three red arrows point upwards to three locations where the welds are missing or incomplete, indicating poor welding quality.</p>
②	 <p>Diagram 2 shows a close-up of a metal bracket assembly. A single green arrow points upwards to a single, continuous blue weld line, indicating a good weld.</p>	 <p>Diagram 2 shows the same metal bracket assembly. A single red arrow points upwards to a location where the weld is missing, indicating a missing weld.</p>
③	 <p>Diagram 3 shows a close-up of a metal bracket assembly. A single green arrow points upwards to a single, continuous blue weld line, indicating a good weld.</p>	 <p>Diagram 3 shows the same metal bracket assembly. A single red arrow points upwards to a location where the weld is missing, indicating a missing weld.</p>
④	 <p>Diagram 4 shows a close-up of a metal bracket assembly. Three green arrows point upwards to three distinct blue weld lines that are continuous and well-defined, indicating good welding quality.</p>	 <p>Diagram 4 shows the same metal bracket assembly. Three red arrows point upwards to three locations where the welds are missing or incomplete, indicating poor welding quality.</p>

The information contained within this document is confidential and protected by U.S. and international copyright laws, and is the property of Polaris Industries. This document is provided for the sole use of authorized Polaris dealers and distributors. This document is not to be distributed, duplicated, or copied, digitally or otherwise, without the written consent of Polaris Industries Inc.

T-18-01-A SEAT SLIDER TEST

1. While sitting in the seat, grab slider bar in the middle of the seat base, and pull up to release slider latches.
2. Pull seat to the fully forward travel position using your legs until the seat slider stops.

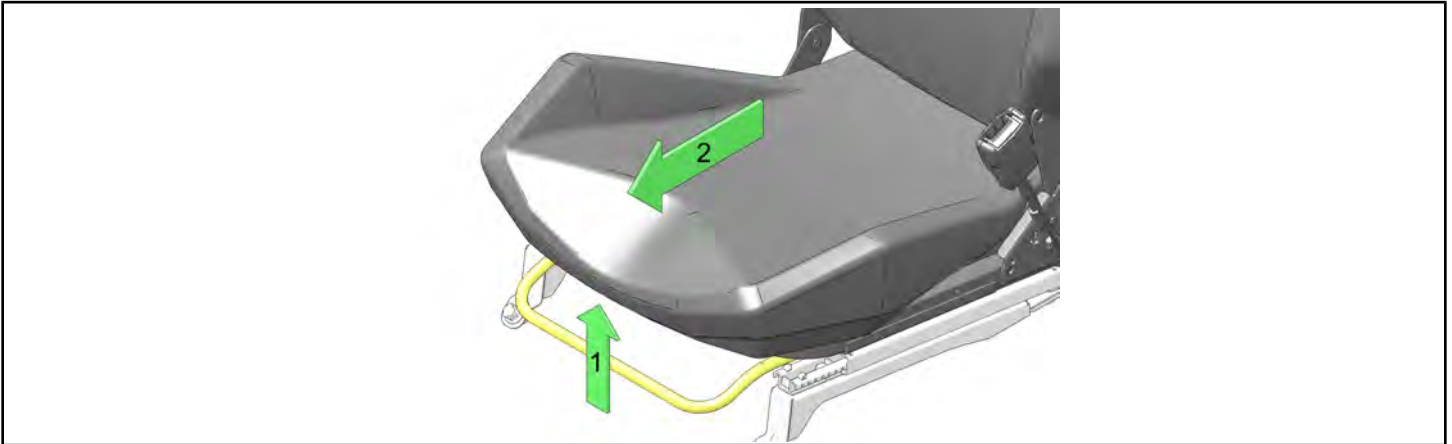

3. Push the seat back slightly, and gently release the slider bar ensuring that it falls all the way down and properly latches into the first slider position.
4. Place one foot on the dead pedal and the other on the brake pedal. Place both hands on the steering wheel. Using your hands and feet, push the seat backward, testing to ensure the seat stays locked in place.
5. Repeat above procedure at the three additional positions below to ensure engagement along the entire seat slider travel range:
 - 1/4 travel position
 - 1/2 travel position
 - 3/4 travel position

STOP!

If the seat unlatches or moves more than one tooth rearward in ANY of the four positions, the test is considered a FAIL and a new seat base MUST be installed:

- **If the seat passes both the Seat Base Frame Weld Inspections, page 6, and Seat Slider Test on page 11, then no seat base replacement is required. File a claim for T-18-01-A.**

T-18-01-B DRIVER-SIDE SEAT BASE FRAME REPLACEMENT

KIT CONTENTS (P/N 2207822)

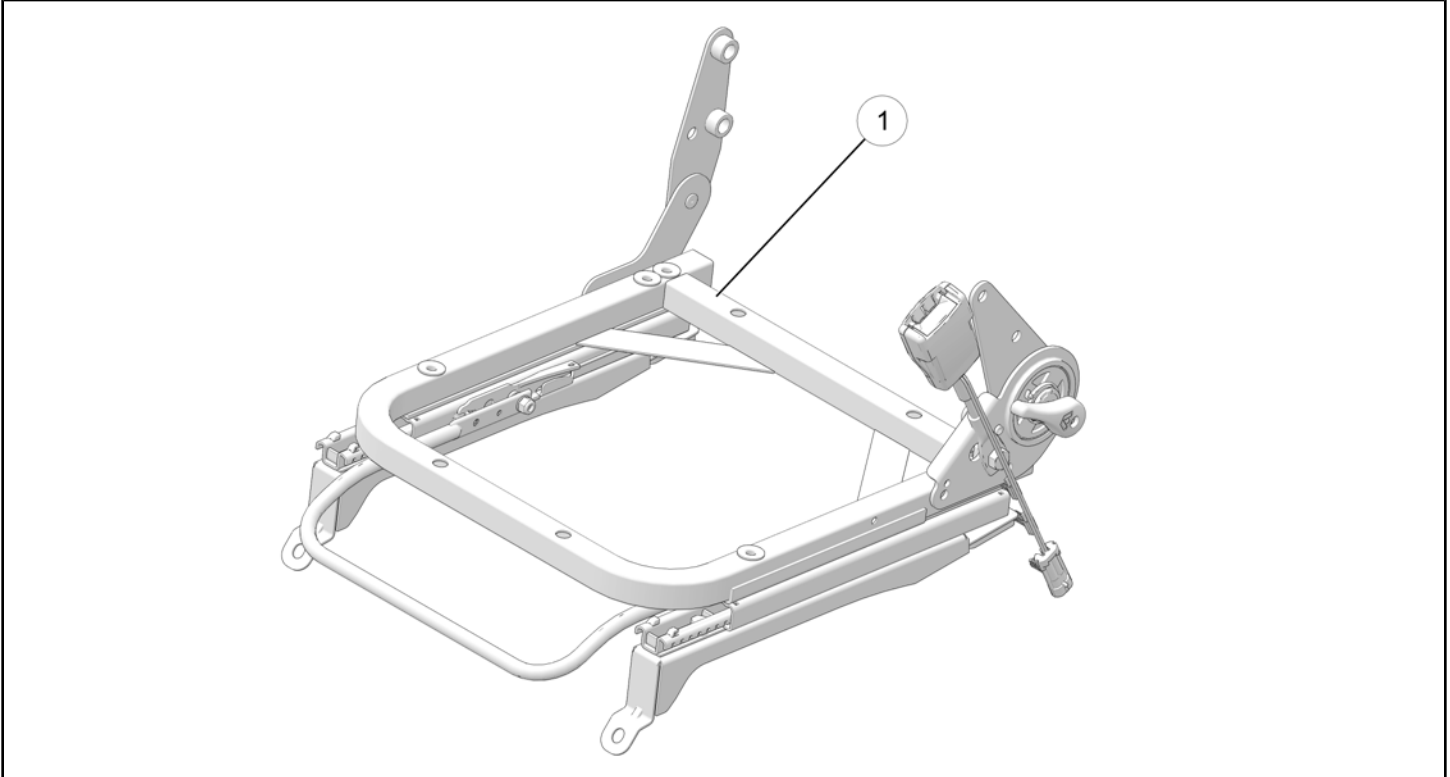

ITEM	DESCRIPTION	PART NUMBER	QTY
①	Frame, Seat Bottom, Driver	2207822	1
	Instructions, Kit (not shown)	9929216	1

TOOLS REQUIRED

- Trim Removal Tool
- 8 mm Socket or T30 Torx
- 15 mm Socket
- Socket Wrench
- Torque Wrench

The information contained within this document is confidential and protected by U.S. and international copyright laws, and is the property of Polaris Industries. This document is provided for the sole use of authorized Polaris dealers and distributors. This document is not to be distributed, duplicated, or copied, digitally or otherwise, without the written consent of Polaris Industries Inc.

DRIVER-SIDE SEAT BASE FRAME REMOVAL

IMPORTANT

Retain and remember the location of all fasteners for installation of the new seat base frame.

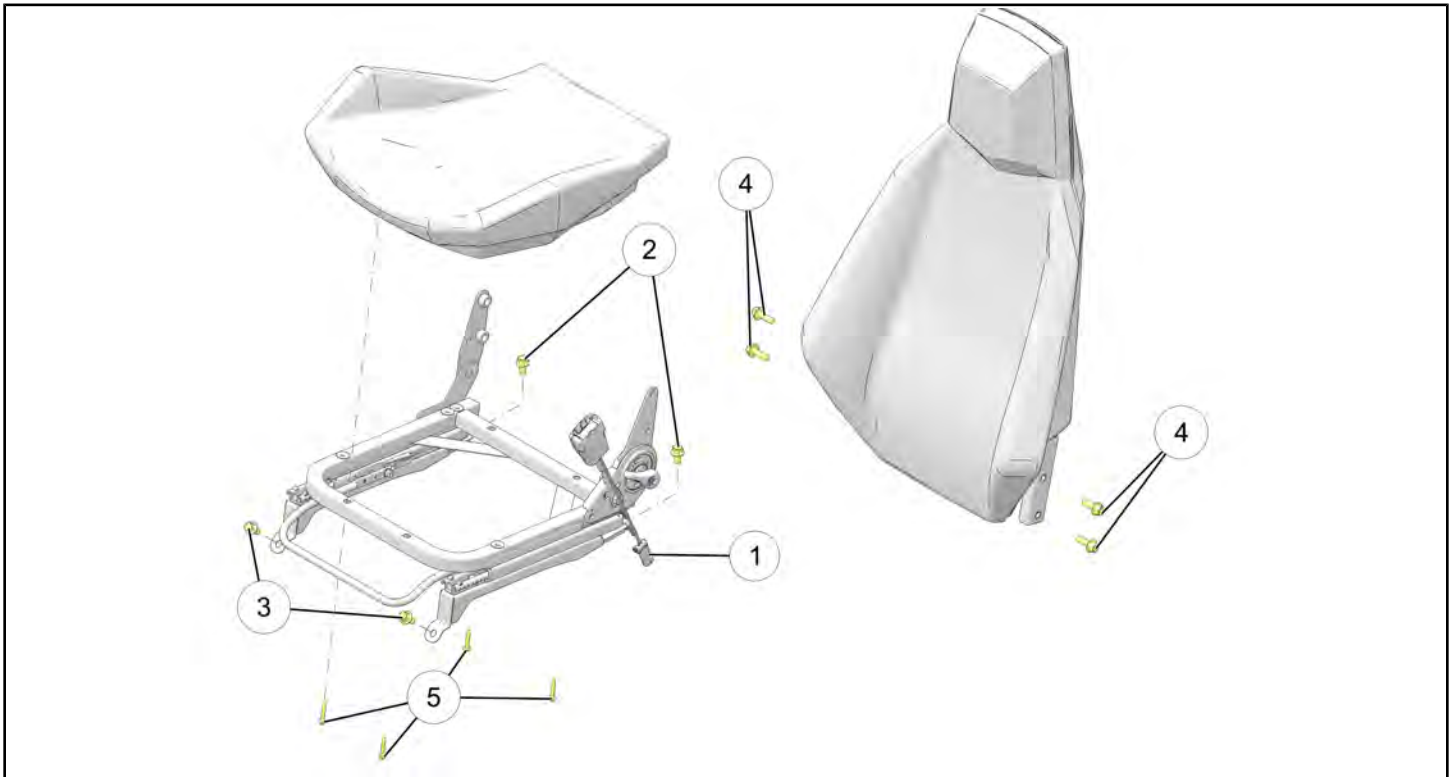

ITEM	DESCRIPTION	LOCATION	FASTENER DETAILS
①	Seatbelt Switch Connector	Connector mounted on the back of the rear seat frame rail	—
②	Seat Base Fasteners, Rear	Rear of seat base	15 mm Hex / 20 mm Length (QTY 2)
③	Seat Base Fasteners, Front	Front of seat base	15 mm Hex / 20 mm Length (QTY 2)
④	Seat Back to Seat Base Fasteners	Both sides of the seat back securing the seat back to the seat base	15 mm Hex / 30 mm Length (QTY 4)
⑤	Seat Bottom Cushion Fasteners	Bottom of seat base	8 mm or T-30 Torx (QTY 4)

Slingshade Equipped Models Only: Unlock and open Slingshade door before performing this procedure.

1. Slide seat to the forward-most position and tilt seat forward toward the steering wheel.
2. Disconnect the seatbelt switch electrical plug ① located along the back of seat rail.
 - 2015 and 2016 vehicles include a second electrical connector mounted to the rear seatbase frame rail's bottom surface. Separate electrical connector from the seat base by forcing the connector fir tree pin out of the hole in the frame with a trim removal tool.

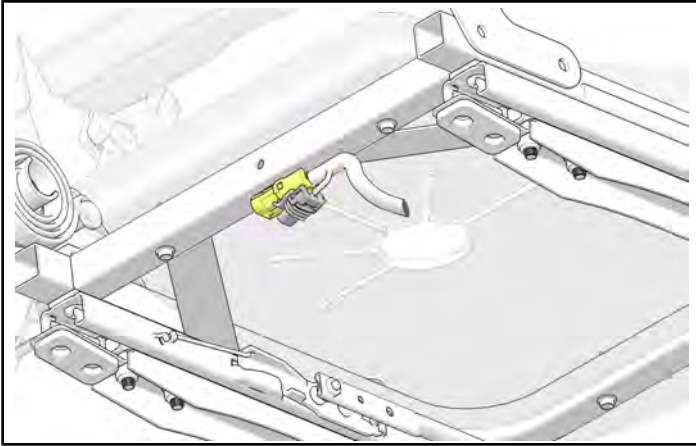

3. Remove the two rear seat fasteners ②.
4. Slide seat to the rear-most position and tilt the seatback toward the rear of the vehicle.
5. Remove the two front seat fasteners ③.

6. Carefully remove seat assembly from vehicle.

IMPORTANT

Verify electrical connector(s) have been disconnected before removing seat.

CAUTION

Seat base assembly is heavy! Use care when removing from vehicle.

CAUTION

DO NOT lift the seat base using the slider bar during removal. Doing so may allow the seat to slide and damage other components.

7. Remove four fasteners ④ to disassemble the seatback frame assembly.

CAUTION

Place seatback frame assembly on a soft, clean surface to prevent damage.

8. Remove four fasteners ⑤ and disassemble seat bottom cushion from seat base frame.

CAUTION

Place seat bottom cushion on a soft, clean surface to prevent damage.

IMPORTANT

Retain and remember the location of all fasteners for installation of the new seat base frame.

T-18-01-B DRIVER-SIDE SEAT BASE FRAME INSTALLATION

1. Assemble seat bottom cushion to NEW seat base frame by installing four 8 mm / T30 fasteners ⑤. Torque to specification.

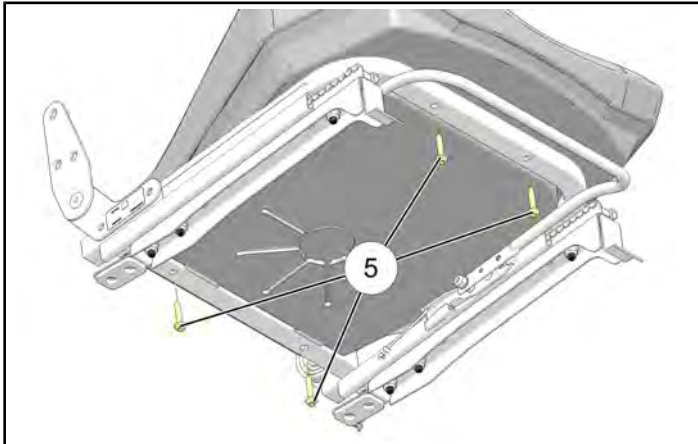

CAUTION

DO NOT over torque seat bottom fasteners. Over torquing will result in seat damage.

TORQUE

Seat Bottom Cushion Fasteners:
24 in-lbs (3 Nm)

2. Assemble seatback frame assembly by installing four fasteners ④ (see diagram below to verify correct fastener size). Torque to specification.

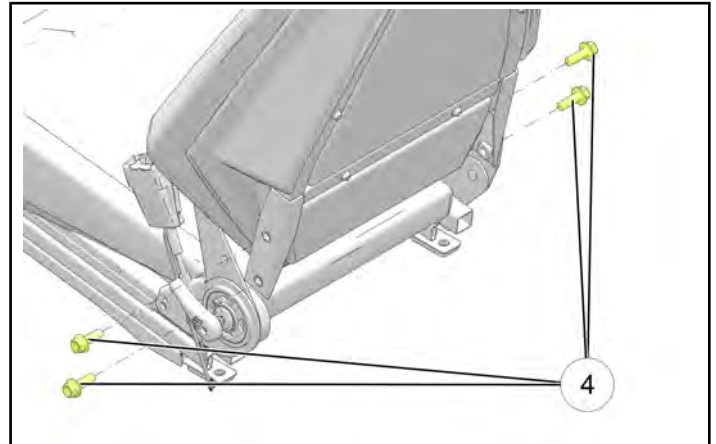

1:1 scale (15 mm Hex / 30 mm Length)

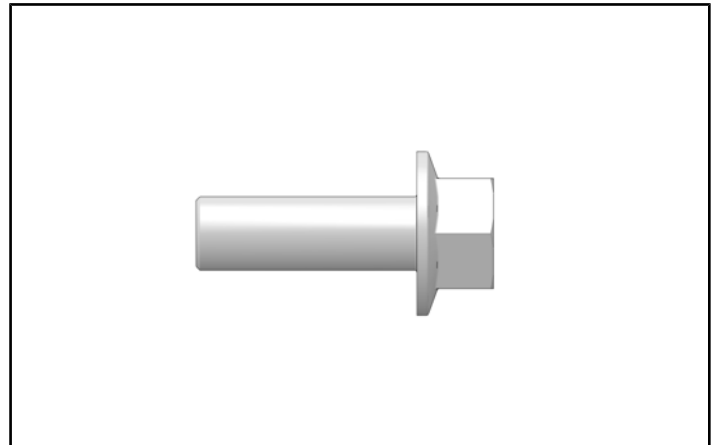

TORQUE

Seat Back to Seat Base Fasteners:
35 ft-lbs (47 Nm)

IMPORTANT — AUDIT STEP

A secondary dealer representative must verify all four seatback frame fasteners have been torqued using a torque wrench set to the correct specification.

- ALL Models:** Position the wiring harness to align with the recess in the floor to ensure the harness routes freely under the seat rail after the seat has been installed.

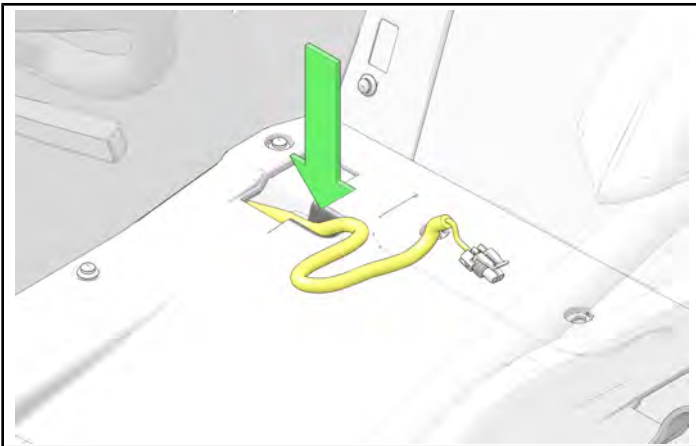

- Set both sliders to be positioned in the same latch location (front-to-back) to prevent the sliders from binding after assembly.

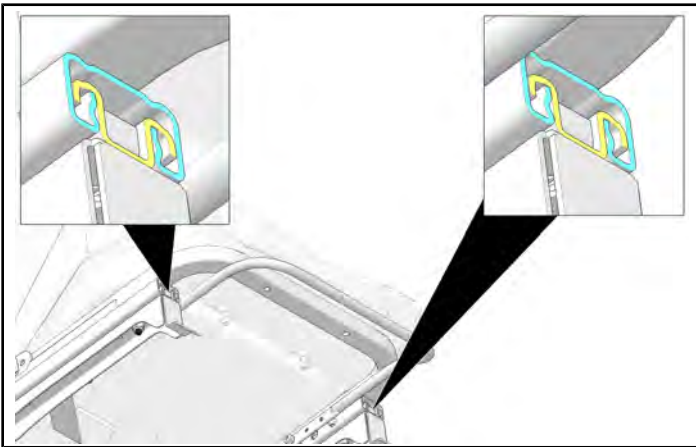

- Carefully install seat assembly into vehicle.

CAUTION

DO NOT lift the seat base using the slider bar during installation. Doing so may allow the seat to slide and damage other components.

IMPORTANT

Do not adjust seat slider until all four seat base frame fasteners have been torqued to specification

- Tilt seat forward. Route seatbelt switch wire ① under outboard frame rail, approximately midway along its length.

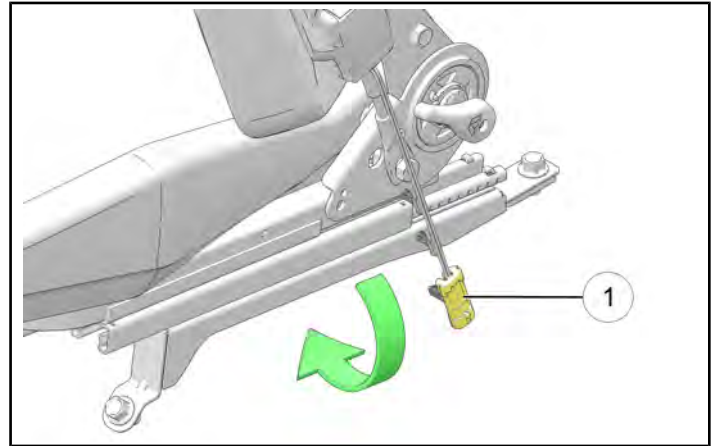

- Connect the seatbelt switch electrical plug (connected to the harness) to the connector mounted to the seat frame. Gently pull on connector to ensure locking tab is engaged.

NOTE

2015-2016 models allow second electrical connector to hang loose.

- Align the rear seatbase mounting holes with the vehicle and install the two rear seat fasteners ②. Leave fasteners loose to ease assembly of the front fasteners.

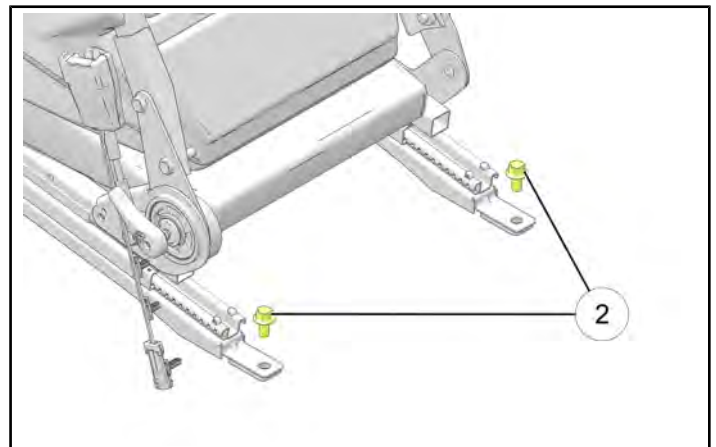

IMPORTANT — AUDIT STEP

A secondary dealer representative must verify the wiring harness and seatbelt buckle harness routing to ensure they are not pinched by the seat frame rails and ensure the seatbelt switch connector is properly connected.

- Slide seat to the rear-most position and tilt the seatback toward the rear of the vehicle.

10. Using a 15 mm socket, install and torque the two front seat fasteners ③ to specification.

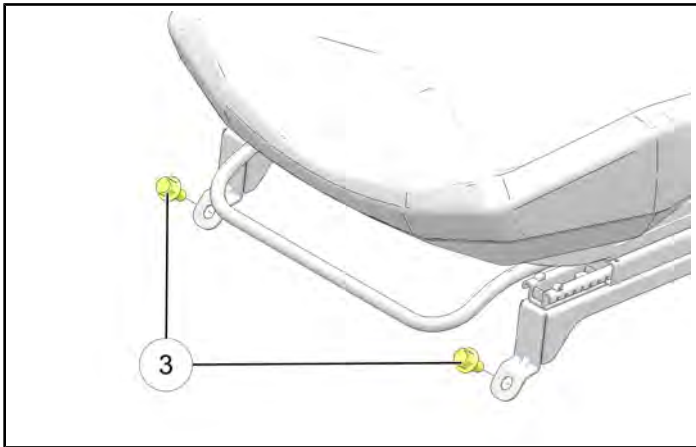

TORQUE

Seat Base Fasteners:
35 ft-lbs (47 Nm)

11. Slide seat to the forward-most position and tilt seat forward toward the steering wheel.

12. Using a 15 mm socket, torque the two rear seat fasteners ② to specification.

TORQUE

Seat Base Fasteners:
35 ft-lbs (47 Nm)

IMPORTANT — AUDIT STEP

A secondary dealer representative must verify all four seat base fasteners have been torqued using a torque wrench set to the correct specification.

13. Perform the seat slider functional test on the new seat assembly. See seat inspection instructions page 6.

IMPORTANT — AUDIT STEP

A secondary dealer representative must confirm successful completion of the slider functionality test.

14. Turn key on and fasten seat belt buckle to ensure the indicator light is not present.

IMPORTANT — AUDIT STEP

A secondary dealer representative must verify the seatbelt switch indicator light disappears after connecting seatbelt buckle.

15. Remove protective mats and inspect for damage.

16. Only File a claim for T-18-01-B if driver seat base frame was replaced. If both driver and passenger seat base frames were replaced, file a claim for T-18-01-D.

T-18-01-C PASSENGER-SIDE SEAT BASE FRAME REPLACEMENT

KIT CONTENTS (P/N 2207823)

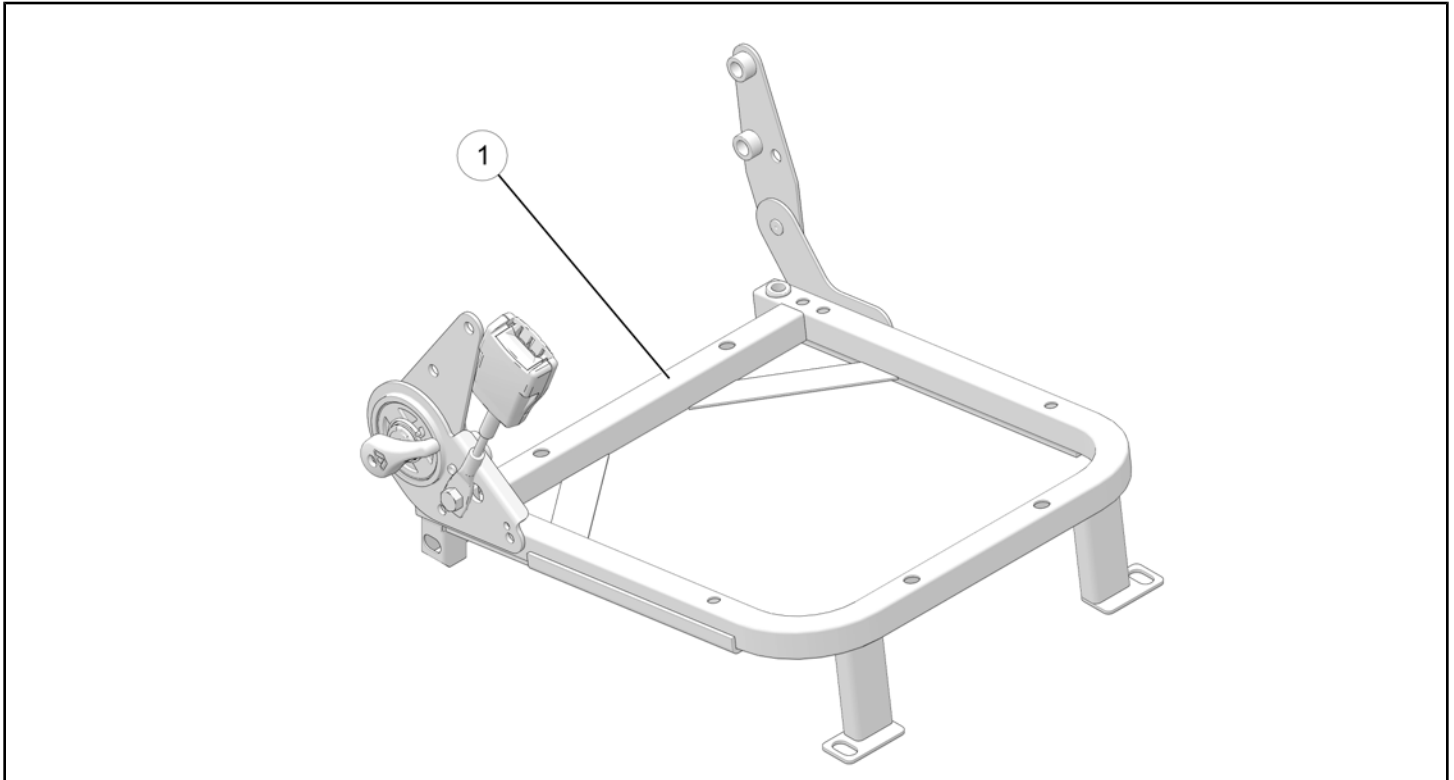

ITEM	DESCRIPTION	PART NUMBER	QTY
①	Frame, Seat Bottom, Passenger	2207823	1
	Zip Tie (not shown)	7081496	1
	Instructions, Kit (not shown)	9929216	1

TOOLS REQUIRED

- Trim Removal Tool
- Side Cutter
- T27 Torx
- 8 mm Socket or T30 Torx
- 15 mm Socket
- 16 mm Socket
- 16 mm Open End Wrench
- Socket Wrench
- Torque Wrench

PASSENGER-SIDE SEAT BASE FRAME REMOVAL

IMPORTANT

Retain and remember the location of all fasteners for installation.

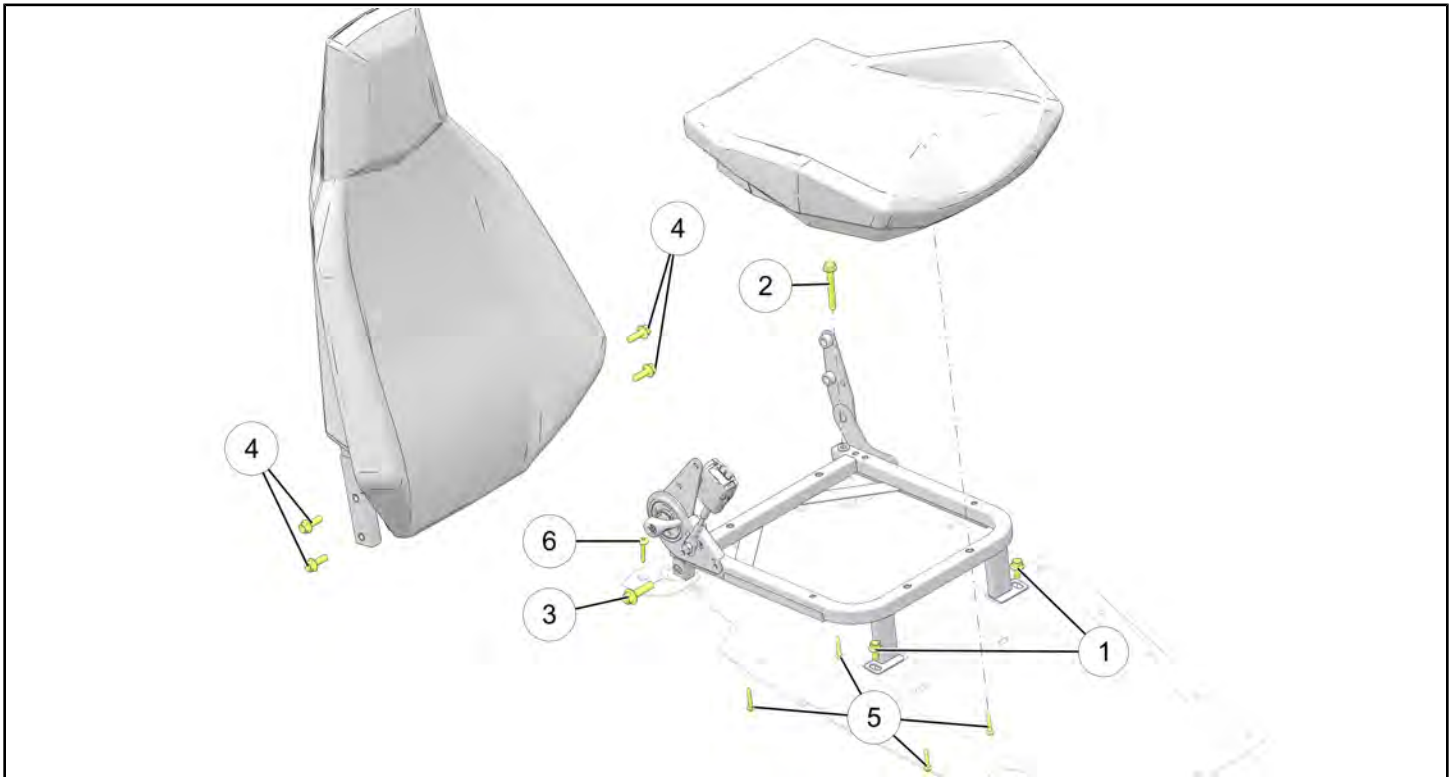

ITEM	DESCRIPTION	LOCATION	FASTENER DETAILS
①	Seat Fasteners, Front	Front of seat base	15 mm Hex / 20 mm Length (QTY 2)
②	Seat Base Fastener, Rear Vertical	Rear of seat base	15 mm Hex / 84 mm Length (QTY 1)
③	Seat Base Fastener, Rear Horizontal	Rear of seat base	16 mm Hex / 45 mm Length (QTY 1)
④	Seat Back to Seat Base Fasteners	Both sides of the seat back securing the seat back to the seat base	15 mm Hex / 30 mm Length (QTY 4)
⑤	Seat Bottom Cushion Fasteners	Bottom of seat base	8 mm Hex or T-30 Torx (QTY 4)
⑥	Floor Pan Fastener	Rear left side of seat base	T-27 Torx (QTY 1)

1. **Slingshade Equipped Models Only:** Unlock and open Slingshade door.
2. Remove the two front seat fasteners ①.
3. Remove the vertical rear seat fastener ②.
4. Tilt seat forward toward the dash.

5. **2015 / 2016 Models Only:**

2015 / 2016 models were designed to include an electrical connector mounted to the rear seatbase frame rail's bottom surface. Separate the electrical connector from the seat base by forcing the connector fir tree pin out of the hole in the frame with a trim removal tool.

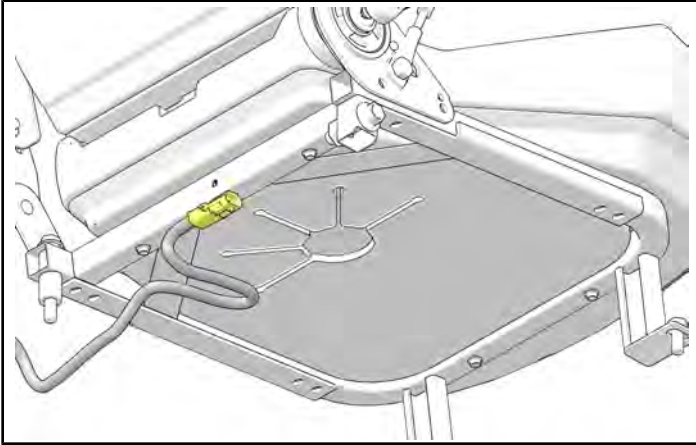

6. **2017 – 2019 Models Only:**

Remove T27 Torx fastener ⑥ securing the floor pan to the frame.

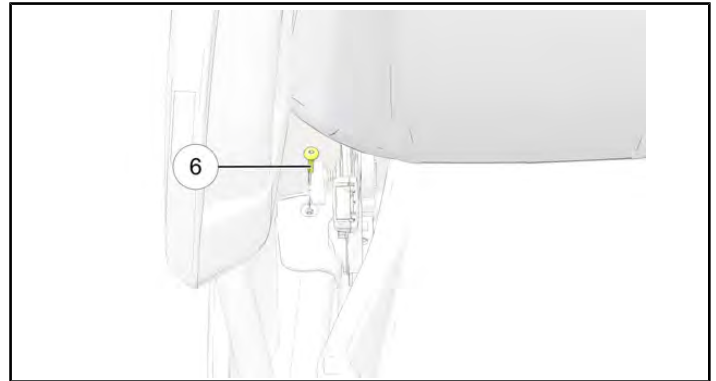

Deflect floor pan slightly upward to gain access to horizontal rear seat fastener ③.

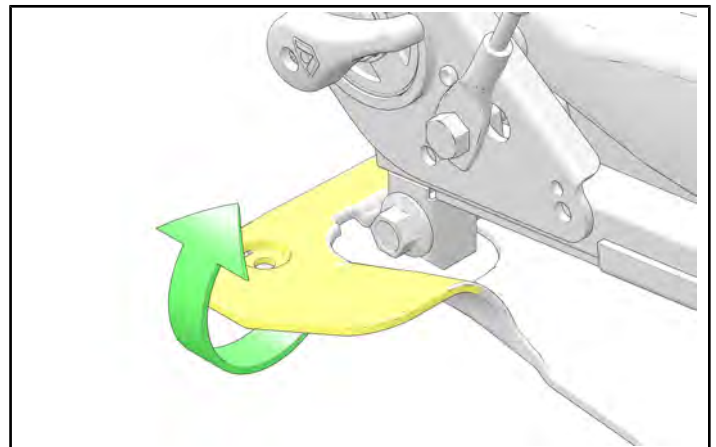

CAUTION

Cover wrench head with a rag to prevent damage to interior panel.

7. Remove the horizontal rear seat fastener ③.
8. Tilt the seatback toward the rear of the vehicle.
9. Carefully remove seat assembly from vehicle.

⚠ CAUTION

Seat base assembly is heavy! Use care when removing from vehicle.

10. Remove the four fasteners ④ to disassemble the seatback frame assembly.

CAUTION

Place seatback frame assembly on a soft, clean surface to prevent damage.

11. Remove the four fasteners ⑤ and disassemble the seat bottom cushion from the seat base frame.

CAUTION

Place seat bottom cushion on a soft, clean surface to prevent damage.

IMPORTANT

Retain and remember the location of all fasteners for installation of the new seat base frame.

T-18-01-C PASSENGER-SIDE SEAT BASE FRAME INSTALLATION

1. Assemble seat bottom cushion to NEW seat base frame by installing four 8 mm / T30 fasteners ⑤. Torque to specification.

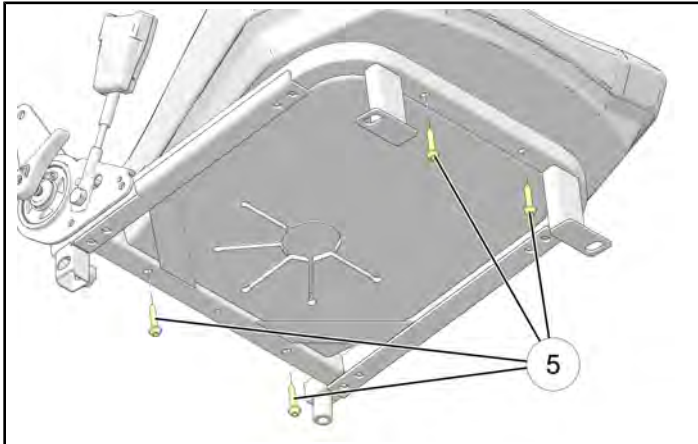

CAUTION

DO NOT over torque seat bottom fasteners. Over torquing will result in seat damage.

TORQUE

Seat Bottom Cushion Fasteners:
24 in-lbs (3 Nm)

2. Assemble seatback frame assembly by installing four fasteners ④ (see diagram below to verify correct fastener size). Torque to specification.

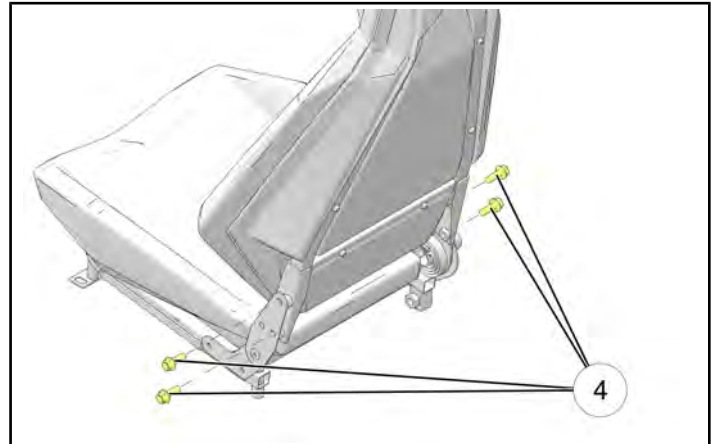

1:1 scale (15 mm Hex / 30 mm Length)



TORQUE

Seat Back to Seat Base Fasteners:
35 ft-lbs (47 Nm)

IMPORTANT — AUDIT STEP

A secondary dealer representative must verify all four seatback frame fasteners have been torqued using a torque wrench set to the correct specification.

3. 2015 / 2016 Models Only:

Assemble the supplied fir tree pin to the electrical connector with the supplied zip tie.

- a. Cut the fir tree pin off the connector with a side cutter.
- b. Attach the cable tie mount to the male connector with the supplied cable tie.



- c. Position the wiring harness to align with the recess in the floor to ensure the harness routes freely under the seat rail after the seat has been installed.

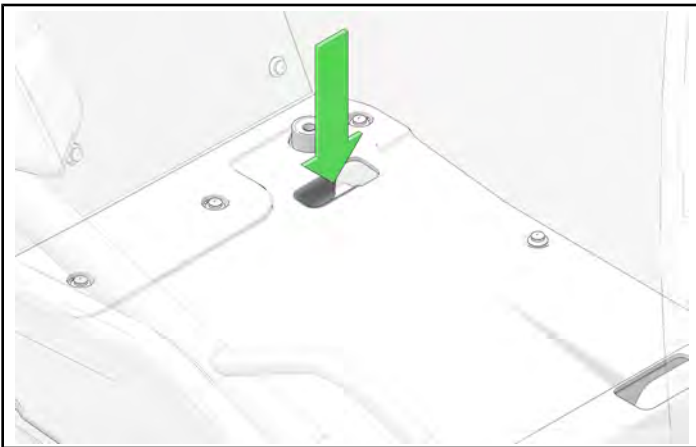

4. Carefully position seat assembly into vehicle.
5. Carefully tilt seat forward toward the dash.

6. 2015 / 2016 Models Only:

- Insert the connector mounting pin into the hole in the bottom of the seatbase frame rail. After installing pull gently downward to ensure connector mounting pin is fully engaged.

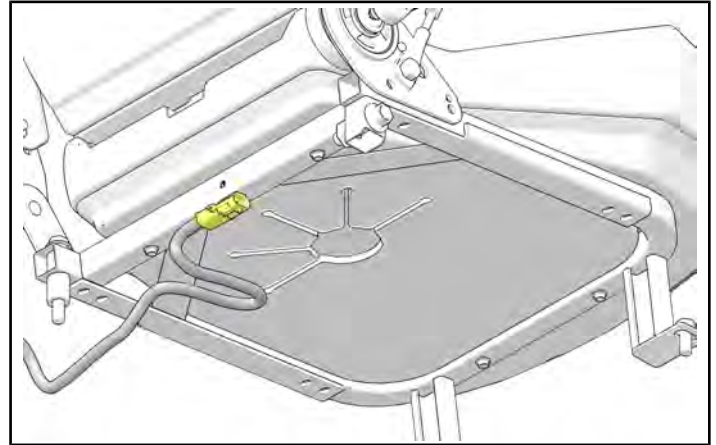

7. Using a 15 mm socket, loosely install vertical rear seat fastener ②.

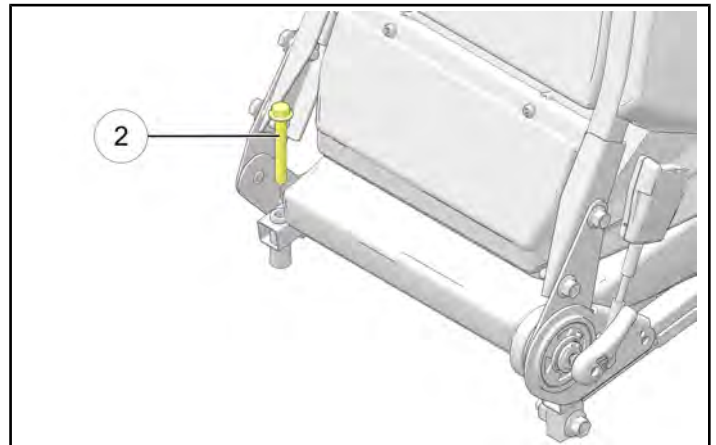

8. 2017 – 2019 Models Only:

Deflect floor pan slightly upward to gain access to horizontal seat base fastener ③.

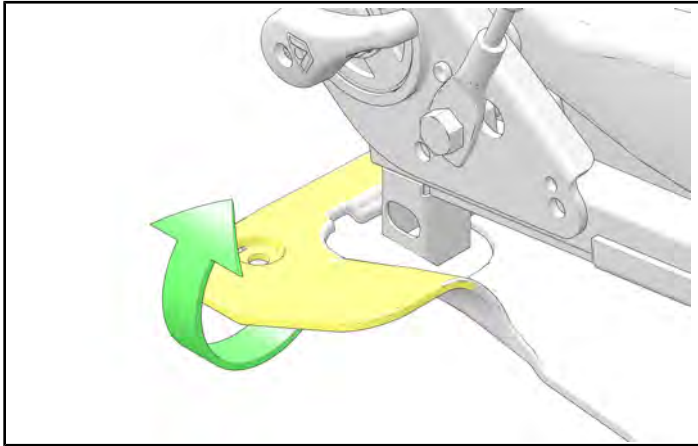

CAUTION

Cover wrench head with a rag to prevent damage to interior panel.

9. Using a 16 mm socket, loosely install horizontal seat base fastener ③.

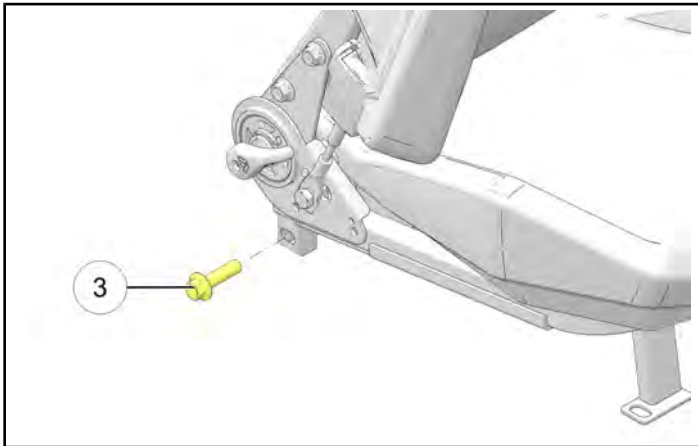

10. Align the front seatbase mounting holes with the vehicle and loosely install the two front seat fasteners ①. Leave fasteners loose to ease final assembly of the rear fasteners.

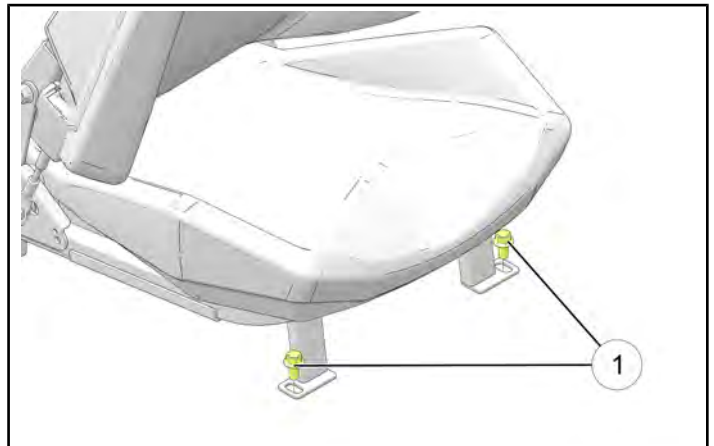

11. Using a 16 mm socket, Torque horizontal seat base fastener ③ that was loosely installed in STEP 8.

TORQUE

Horizontal Seat Base Fastener:
40 ft-lbs (54 Nm)

IMPORTANT — AUDIT STEP

2015–2016 Models: A secondary dealer representative must verify that the vehicle wiring harness is aligned with the recess in the floor and is not pinched by the inboard seat mount. Verify that the electrical connector is secured to the seat base frame rail's bottom surface.

IMPORTANT — AUDIT STEP

A secondary dealer representative must verify torque on the rear horizontal seatbase fastener (16 mm Hex / 45 mm Length) using a torque wrench set to the correct specification.

12. 2017 – 2019 Models Only:

Install floor pan fastener ⑥. Torque to specification.

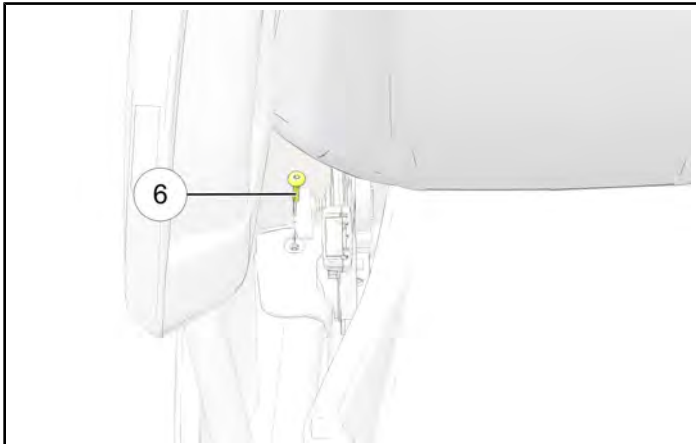

TORQUE

Floor Pan Fastener:
65 in-lbs (7 Nm)

13. Tilt the seatback toward the rear of the vehicle.
Using a 15 mm socket, Torque rear vertical seat base fastener ②.

TORQUE

Vertical Seat Base Fastener:
27 ft-lbs (37 Nm)

IMPORTANT — AUDIT STEP

A secondary dealer representative must verify torque on the rear vertical seatbase fastener (15 mm Hex / 84 mm Length) using a torque wrench set to the correct specification.

14. Using a 15 mm socket, Torque two front seat base fasteners ①.

TORQUE

Front Seat Base Fasteners:
35 ft-lbs (47 Nm)

IMPORTANT — AUDIT STEP

A secondary dealer representative must verify torque on two front seatbase fasteners (15 mm Hex / 20 mm Length) using a torque wrench set to the correct specification.

15. Remove protective mats and inspect vehicle for damage incurred during repair.

16. Only File a claim for T-18-01-C if passenger seat base frame was replaced. If both driver and passenger seat base frames were replaced, file a claim for T-18-01-D.