

F/CMVSS Noncompliance Recall

N192212270 Incorrect Odometer Display



Release Date: February 2019

Revision: 00

Attention: It is a violation of Federal law for a dealer to deliver a new motor vehicle or any new or used item of motor vehicle equipment (including a tire) covered by this notification under a sale or lease until the defect or noncompliance is remedied.

All involved vehicles that are in dealer inventory must be held and not delivered to customers, dealer traded, or used for demonstration purposes until the repair contained in this bulletin has been performed on the vehicle.

Make	Model	Model Year		RPO	Description
		From	To		
Chevrolet	4500 HD/XD Low Cab Forward (LCF)	2019	2019	I1B	ENGINE, DIESEL 5.2L 4 CYL
Chevrolet	5500 HD/XD Low Cab Forward (LCF)	2019	2019	I1B	ENGINE, DIESEL 5.2L 4 CYL

Involved vehicles are marked “open” on the Investigate Vehicle History screen in GM Global Warranty Management system. This site should always be checked to confirm vehicle involvement prior to beginning any required inspections and/or repairs.

Condition	Isuzu Motors Limited manufactured the 2019 model year Chevrolet 4500HD/XD and 5500HD/XD Series Medium Duty trucks equipped with 5.2L diesel engines. Isuzu has decided that some of these vehicles produced between August 24, 2018 and November 17, 2018 fail to comply with the requirements of Federal Motor Vehicle Safety Standard No. 101. As a result, GM is conducting a recall. These may have an odometer which accurately records the distance traveled in miles, but erroneously indicates “km” in the LCD display. The vehicle odometer display may incorrectly list the distance traveled in kilometers when it is actually being recorded in miles.
Correction	Dealers will inspect and if necessary replace the Instrument Panel Cluster (IPC).

Parts

Quantity	Part Name	Part No.
1	INSTRUMENT CLUSTER	98319844

Important: Parts should only be ordered when inspection determines that it is necessary to replace the Instrument cluster assembly.

It is estimated that only 19 vehicles will be involved in this recall and after the inspection there should only be 2 vehicles that require parts replaced. **Due to the small number of vehicles anticipated that will need this fix and the limited initial parts availability, dealers are encouraged not to order these parts for use as shelf stock.**

Reminder: Parts may be removed from Retail Inventory Management (RIM). Dealers should review the affected parts to confirm RIM managed status. Parts may have quantity limiters in effect.

Warranty Information

Labor Operation	Description	Labor Time	Trans. Type	Net Item
9104310	Inspect Only – No Further Action Required	0.2	ZFAT	N/A
9104311	Replace Instrument Cluster (includes inspection)	0.5		

F/CMVSS Noncompliance Recall

N192212270 Incorrect Odometer Display



Service Procedure



5227315

1. From the driver's side, press the odometer switch to display the odometer reading.
 - 1.1. If the odometer reading matches the instrument cluster (for example, "MI" on the display and "MPH" on the instrument cluster), instrument cluster assembly replacement is NOT required. No further action required.
 - 1.2. If the odometer reading does not match the instrument cluster (See Figure 1), the instrument cluster assembly MUST be replaced. Proceed to Step 2.
2. Block the vehicle wheels and apply the parking brake.
3. Disconnect the negative battery cable.



5227317

4. Pull the column shaft lever to the front and adjust the column angle. Ensure the column shaft lever is locked in place.

F/CMVSS Noncompliance Recall

N192212270 Incorrect Odometer Display

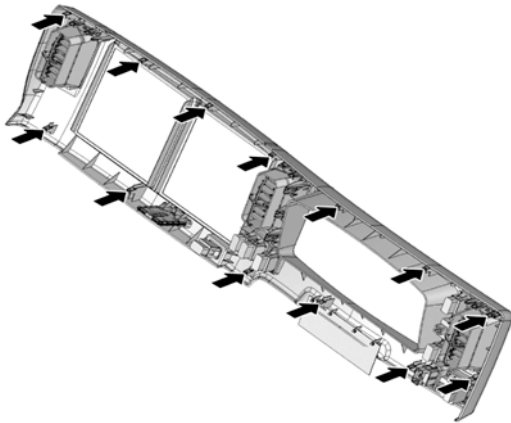

5227319

5. Remove the instrument cluster bezel.

Important: Be careful when removing as to not scratch the bezel or damage the connectors.

- 5.1. Remove the bezel at the 13 clip positions.

- 5.2. Disconnect the cab harness connectors.

6. Remove the incorrect instrument cluster assembly and discard.



5227320

- 6.1. Remove the four (4) Torx® bolts (T25) and set aside for reuse.

- 6.2. Disconnect the cab harness connectors.

F/CMVSS Noncompliance Recall

N192212270 Incorrect Odometer Display



5227321

7. Install the new instrument cluster assembly.

Important: Be careful to not pinch the harness between the IP cluster assembly and the instrument.

- 7.1. Connect the cab harness connectors
- 7.2. Install the four (4) Torx® bolts (T25).

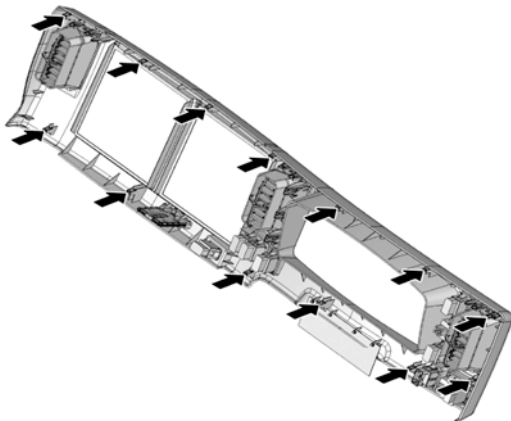

5227319

8. Install the instrument cluster bezel.

Important: Be careful when reinstalling to not scratch the bezel or damage the connectors.

- 8.1. Connect the cab harness connectors.
- 8.2. Push and install the IP cluster bezel at its thirteen (13) clip positions.
9. Connect the negative battery cable.
10. Press the odometer switch to display the odometer reading and confirm it matches to the new instrument cluster.

Dealer Responsibility – For USA

It is a violation of Federal law for a dealer to deliver a new motor vehicle or any new or used item of motor vehicle equipment (including a tire) covered by this notification under a sale or lease until the defect or noncompliance is remedied.

The US National Traffic and Motor Vehicle Safety Act provides that each vehicle that is subject to a recall of this type must be adequately repaired within a reasonable time after the customer has tendered it for repair. A failure to repair within sixty days after tender of a vehicle is prima facie evidence of failure to repair within a reasonable time. If the condition is not adequately repaired within a reasonable time, the customer may be entitled to an identical or reasonably equivalent vehicle at no charge or to a refund of the purchase price less a reasonable allowance for depreciation. To avoid having to provide these burdensome remedies, every effort must be made to promptly schedule an appointment with each customer and to repair their vehicle as soon as possible. In the recall notification letters, customers are told

F/CMVSS Noncompliance Recall

N192212270 Incorrect Odometer Display



how to contact the US National Highway Traffic Safety Administration if the recall is not completed within a reasonable time.

Dealer Responsibility – All

All new, used, GM Certified Used, courtesy transportation vehicles, dealer shuttle vehicles, etc. in dealers' possession and subject to this recall must be held and inspected/repaired per the service procedure of this bulletin before customers take possession of these vehicles. Involved vehicles must be held and not delivered to customers, dealer-traded, released to auction, used for demonstration, or any other purpose.

All GM Certified Used vehicles currently in the dealers' inventory within the Certified Pre-Owned Inventory System (CPOIS) will be de-certified and must be held and remedied per the service procedure in this bulletin. Upon submitting an accepted/paid warranty transaction in the Global Warranty Management (GWM) system, the vehicle can be re-certified for sale within the CPOIS system, or once again be used in the CTP program.

Dealers are to service all vehicles subject to this recall at no charge to customers, regardless of mileage, age of vehicle, or ownership, from this time forward.

Customers who have recently purchased vehicles sold from your vehicle inventory, and for which there is no customer information indicated on the dealer listing, are to be contacted by the dealer. Arrangements are to be made to make the required correction according to the instructions contained in this bulletin. Recall follow-up cards should not be used for this purpose, since the customer may not as yet have received the notification letter.

In summary, whenever a vehicle subject to this recall enters your vehicle inventory, or is in your dealership for service in the future, you must take the steps necessary to be sure the recall correction has been made before selling or releasing the vehicle.

Dealer Reports

For dealers with involved vehicles, a listing with involved vehicles has been prepared and will be provided to U.S. and Canadian dealers through the GM GlobalConnect Recall Reports, or sent directly to export dealers. The listing may contain customer names and addresses obtained from Motor Vehicle Registration Records. The use of such motor vehicle registration data for any purpose other than follow-up necessary to complete this recall is a violation of law in several states/provinces/countries. Accordingly, you are urged to limit the use of this report to the follow-up necessary to complete this recall.

Customer Notification

General Motors will notify customers of this recall on their vehicle.

GM bulletins are intended for use by professional technicians, NOT a "do-it-yourselfer". They are written to inform these technicians of conditions that may occur on some vehicles, or to provide information that could assist in the proper service of a vehicle. Properly trained technicians have the tools, equipment, safety instructions, and know-how to do a job properly and safely. If a condition is described, DO NOT assume that the bulletin applies to your vehicle, or that your vehicle will have that condition. See your dealer for information on whether your vehicle may benefit from the information.



**We Support
Voluntary Technician
Certification**