



N276NAS1

TECHNICAL BULLETIN

31 JAN 2019

© Jaguar Land Rover North America, LLC

NOTE: The information in Technical Bulletins is intended for use by trained, professional Technicians with the knowledge, tools, and equipment required to do the job properly and safely. It informs these Technicians of conditions that may occur on some vehicles, or provides information that could assist in proper vehicle service. The procedures should not be performed by 'do-it-yourselfers'. If you are not a Retailer, do not assume that a condition described affects your vehicle. Contact an authorized Land Rover service facility to determine whether this bulletin applies to a specific vehicle.

INFORMATION

SECTION:

303-01

SUBJECT/CONCERN:

SAFETY RECALL: Center Main Crankshaft Pulley Bolt

AFFECTED VEHICLE RANGE:

MODEL:	MODEL YEAR:	VIN:	ASSEMBLY PLANT:	APPLICABILITY:
Discovery (LR)	2019	400447-400585	Nitra (Slovakia)	V6 S/C 3.0L Petrol

MODEL:	MODEL YEAR:	VIN:	ASSEMBLY PLANT:	APPLICABILITY:
Range Rover Velar (LY)	2019	798495-799721	Solihull	V6 S/C 3.0L Petrol
Range Rover Velar (LY)	2019	200254-207616	Solihull	V6 S/C 3.0L Petrol
Range Rover Sport (LW)	2019	421049-421871	Solihull	V6 S/C 3.0L Petrol /V8 S/C 5.0L Petrol
Range Rover Sport (LW)	2019	829398-839338	Solihull	V6 S/C 3.0L Petrol /V8 S/C 5.0L Petrol
Range Rover (LG)	2019	531120-541393	Solihull	V6 S/C 3.0L Petrol /V8 S/C 5.0L Petrol

MARKETS:

NORTH AMERICA

CONDITION SUMMARY:

This Safety Recall supersedes Update Prior to Sale UPS13118 with immediate effect.

SITUATION:

An issue has been identified on certain Land Rover vehicles within the listed Affected Vehicle Range where the center main crankshaft damper/pulley bolt(s) may fracture. A batch of bolts has been manufactured away from specification and therefore has the potential to develop cracks on the surface of the bolt(s), leading to hydrogen embrittlement. These cracks cause the bolt(s) to fracture over time, leading to a loss of retention of the crankshaft pulley. Where bolt(s) fracture occurs, the pulley will oscillate for a period, but ultimately the crankshaft nose will break, leading to engine failure.

Fracture of the center main crankshaft pulley bolt(s) and associated breakage of the crankshaft nose will lead to the vehicle displaying a number of warning lights, quickly followed by loud noises, engine power loss, and the potential for engine failure. Further, the loose pulley could damage engine compartment components or puncture the hood and become a hazard to pedestrians or other road users.

Vehicles with a bolt(s) from the affected batch may cut out while in motion with no ability to be restarted.

Engine cut-out with minimal warning poses an unreasonable risk to safety and may result in a crash.

ACTION:

Retailers are required to HOLD affected new vehicles that are within your control and refrain from releasing the vehicles for new vehicle sale pending completion of the Diagnostic/Workshop Procedure detailed in this Technical Bulletin. Unsold vehicles should have this performed as part of the Pre-Delivery Inspection (PDI) process but must have it completed prior to vehicle handover to the customer.

Affected vehicles already in the hands of customers should be updated at the next available opportunity.

PARTS:

NOTE:

Only order the expected percentage demand of parts identified.

DESCRIPTION	PART NUMBER/SUNDRY CODE	QUANTITY/VALUE	EXPECTED PERCENTAGE DEMAND
Bolt(s) - Center main crankshaft pulley	LR011952	1	100

SPECIAL TOOLS:

Refer to TOPIx Workshop Manual/Workshop Procedure for any required special tools.

WARRANTY:

NOTE:

Use the Jaguar Land Rover claims submission system to make sure that a vehicle is affected by this program prior to undertaking any rework action.

At the time of confirming a booking for vehicle repair, make sure that all open Recall and Service Actions are identified to make sure the correct parts are available and adequate workshop time is allocated for repairs to be completed at one visit.

Warranty claims must be submitted quoting the Program Code and the relevant Option Code; this will result in payment of the stated time. The SRO and parts information is included for information only. The Option Code(s) that allows for the drive in/drive out allowance may only be claimed if the vehicle is brought back into the workshop for this action alone to be undertaken.

Repair procedures are under constant review and therefore times/prices are subject to change; those quoted here must be taken as guidance only. Use TOPIx to obtain the latest repair time.

Warranty claims must be submitted or payment within 30 calendar days of completion of the repair.

PROGRAM CODE	OPTION CODE	DESCRIPTION	SRO	TIME (HOURS)	PART NUMBER/SUNDRY CODE	QUANTITY/VALUE
N276	A	Discovery, Range Rover Sport, Range Rover Crankshaft pulley bolt(s) - Renew	12.21.89.01	0.9	LR011952	1
N276	B	Discovery, Range Rover Sport, Range Rover Crankshaft pulley bolt(s) - Renew Drive in/drive out	12.21.89.01 02.02.02	0.9 0.2	LR011952 -	1 -
N276	C	Range Rover Velar Crankshaft pulley bolt(s) - Renew Drive in/drive out	12.21.89.01	1.5	LR011952	1
N276	D	Range Rover Velar Crankshaft pulley bolt(s) - Renew Drive in/drive out	12.21.89.01 02.02.02	1.5 0.2	LR011952 -	1 -

Normal Warranty policies and procedures apply.

WORKSHOP PROCEDURE:

 CAUTION:

The center main crankshaft pulley/damper bolt is left-hand thread.

 NOTES:

- Some variation in the illustrations may occur, but the essential information is always correct.
- Some components shown removed for clarity.

1

 NOTE:

Discovery, Range Rover Sport, Range Rover only.

Remove the cooling fan and shroud (see TOPIx Workshop Manual section 303-03: Engine Cooling - Cooling Fan and Shroud).

- 1 When all tasks are finished, go to Step 3.

2

 NOTE:

Range Rover Velar only.

Remove the radiator (see TOPIx Workshop Manual section 303-03: Engine Cooling - Radiator).

- 1 When all tasks are finished, go to Step 3.

3

Remove the engine undershield (see TOPIx Workshop Manual section 501-02: Front End Body Panels - Engine Undershield).

4

 NOTE:

Do not discard the 2 outer crankshaft pulley bolt(s).

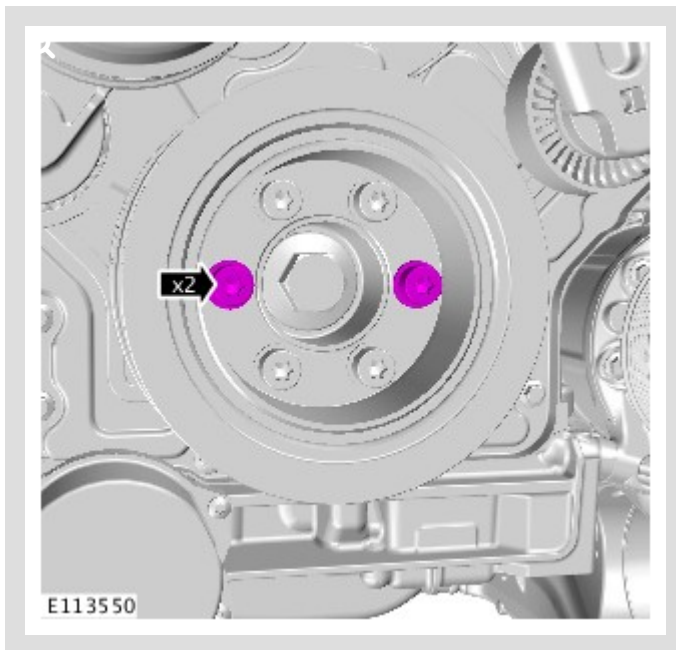

Remove and set to the side **only** the 2 highlighted outer crankshaft pulley bolt(s).

5

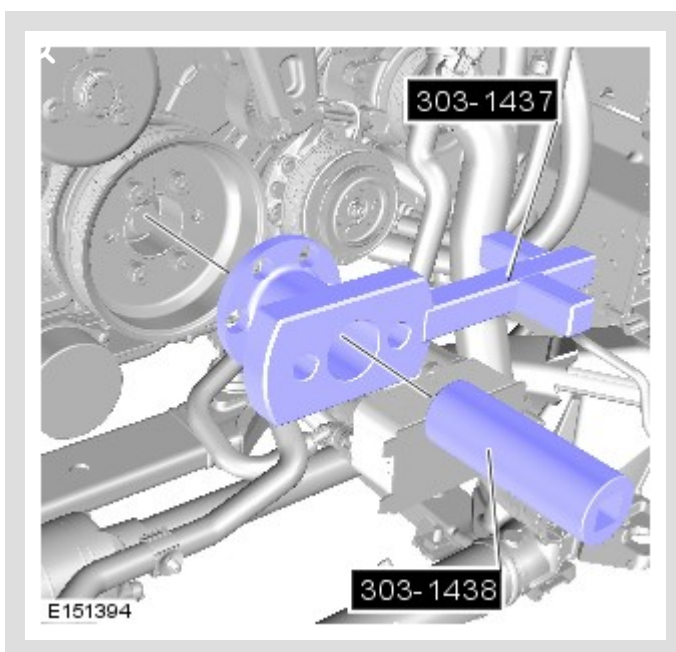

Install the special tools **303-1437** and **303-1438** as shown.

6

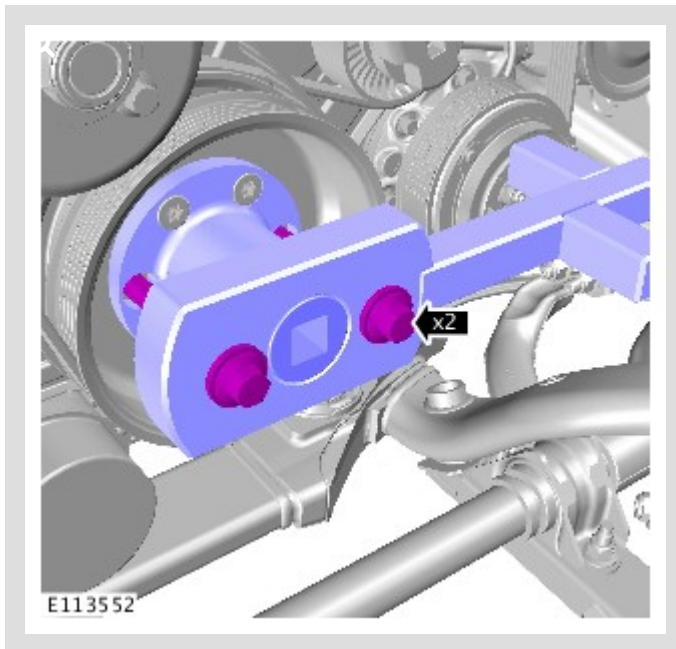

Using the bolt(s) for special tool 303-1437, install the 2 bolt(s) to the crankshaft pulley.

- Torque: **25 Nm**

7

ⓘ CAUTION:

Use care when positioning the vehicle stand.

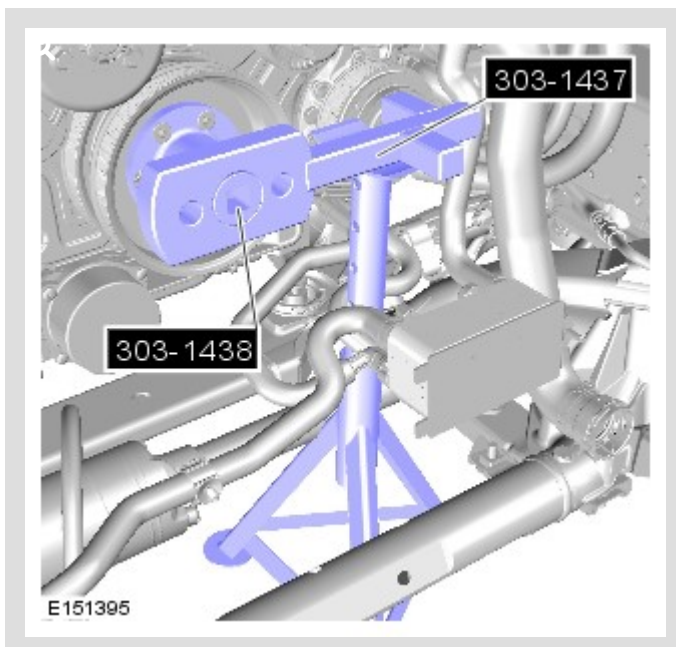

Use a suitable vehicle stand to support the special tools **303-1437** and **303-1438**.

⚠ CAUTIONS:

- **The center main crankshaft pulley/damper bolt(s) is left-hand thread.**
- Do not use air tools to remove the center main crankshaft pulley bolt(s).

⚠ NOTE:

Loosen the center main crankshaft pulley bolt(s) by hand progressively.

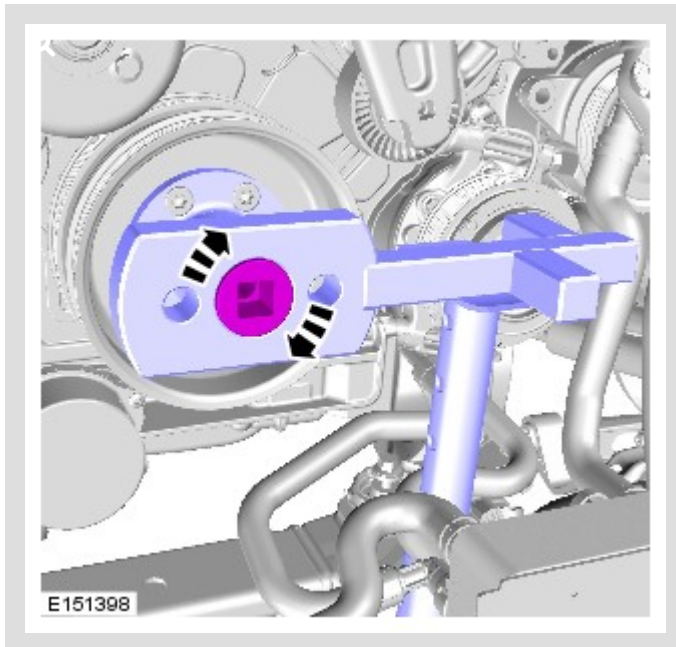

Remove the center main crankshaft pulley bolt(s).

- If the center main crankshaft pulley bolt(s) does not break during removal, go to Step 9.
- If the center main crankshaft pulley bolt(s) does break, remove the broken bolt from the crankshaft without damage to the crankshaft and pulley/damper.

⚠ NOTE:

The time for removing a broken center main crankshaft pulley bolt(s) must be claimed under Warranty as a separate claim.

- If assistance is required, submit a TA (Technical Assistance) request.

9

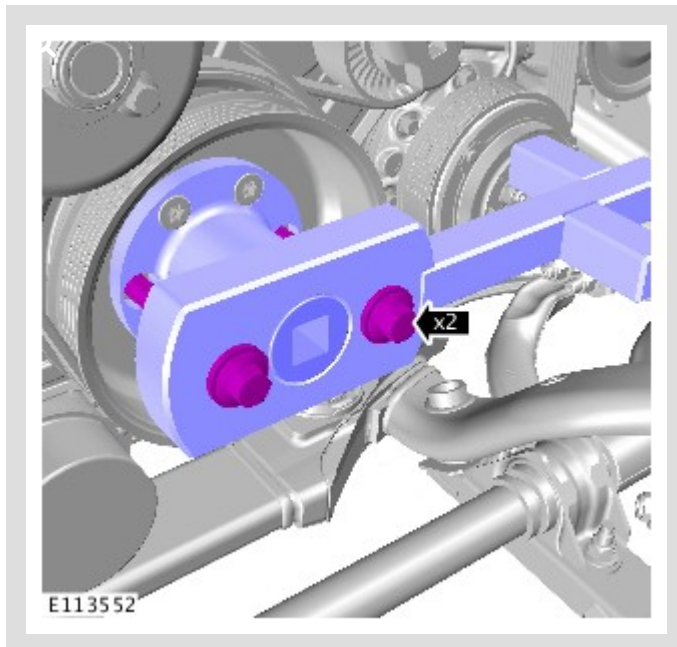

Remove the 2 bolt(s) from special tool **303-1437**.

10

ⓘ CAUTION:

Use care when removing the vehicle stand.

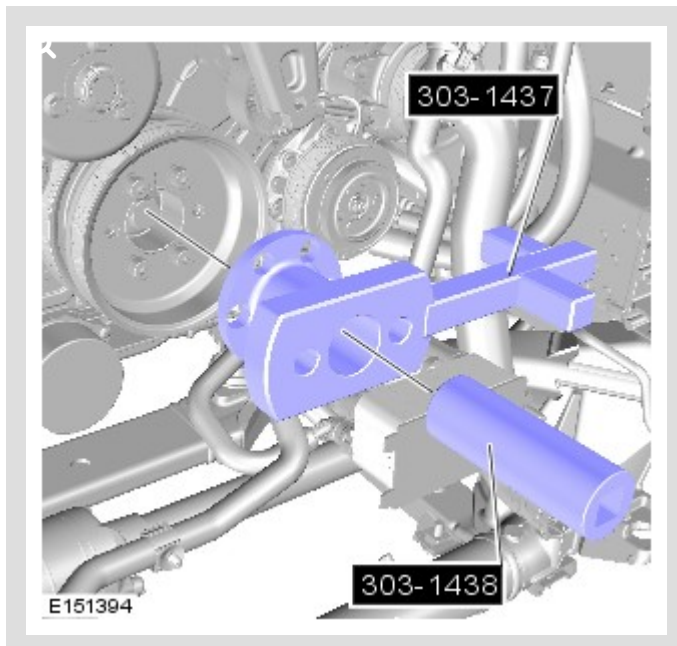

Remove the vehicle stand and special tools **303-1437** and **303-1438**.

11

ⓘ CAUTION:

The center main crankshaft pulley/damper bolt is left-hand thread.

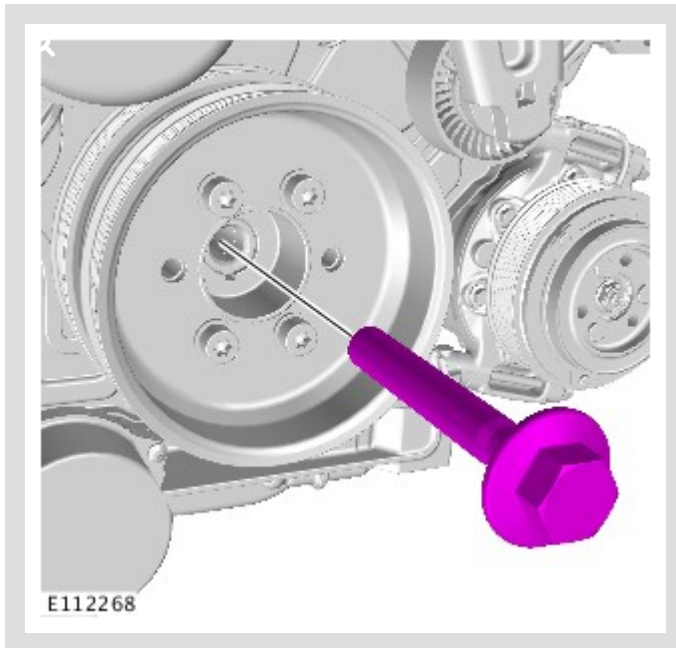

Remove and discard the center main crankshaft pulley bolt(s).

12

ⓘ CAUTION:

The center main crankshaft pulley/damper bolt is left-hand thread.

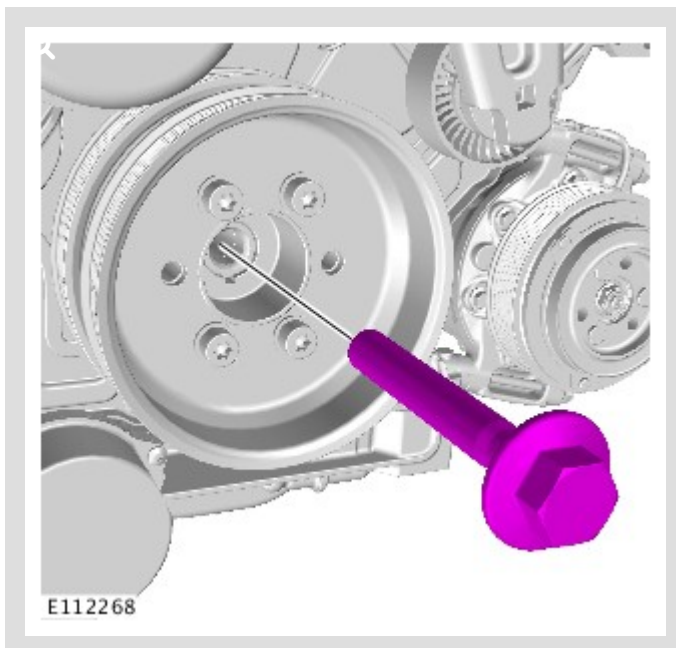

Install the new center main crankshaft pulley bolt(s).

13

ⓘ CAUTION:

Use care when positioning the vehicle stand.

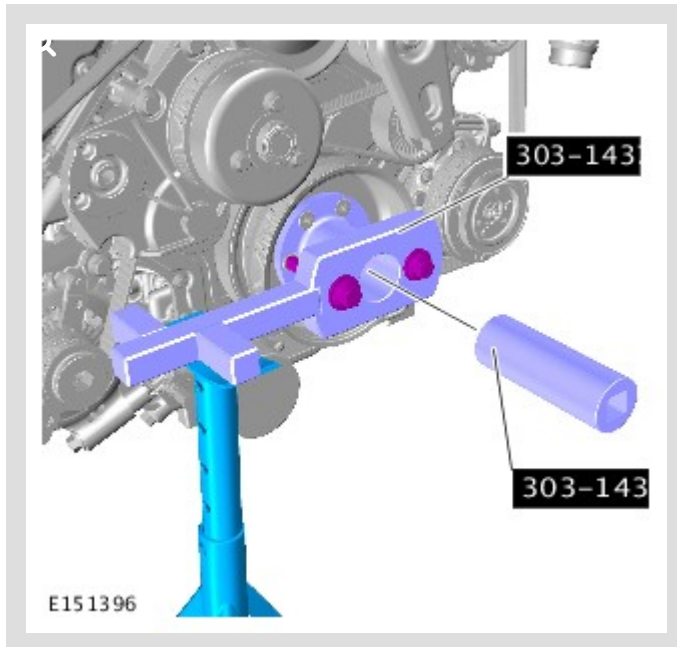

Install the special tools **303-1437** and **303-1438**.

- 1 Using the bolt(s) for special tool 303-1437, install the 2 bolt(s) to the crankshaft pulley.
 - Torque: **25 Nm**
- 2 Use a vehicle stand to support the special tools **303-1437** and **303-1438**.

14

⚠ CAUTION:

The center main crankshaft pulley/damper bolt is left-hand thread.

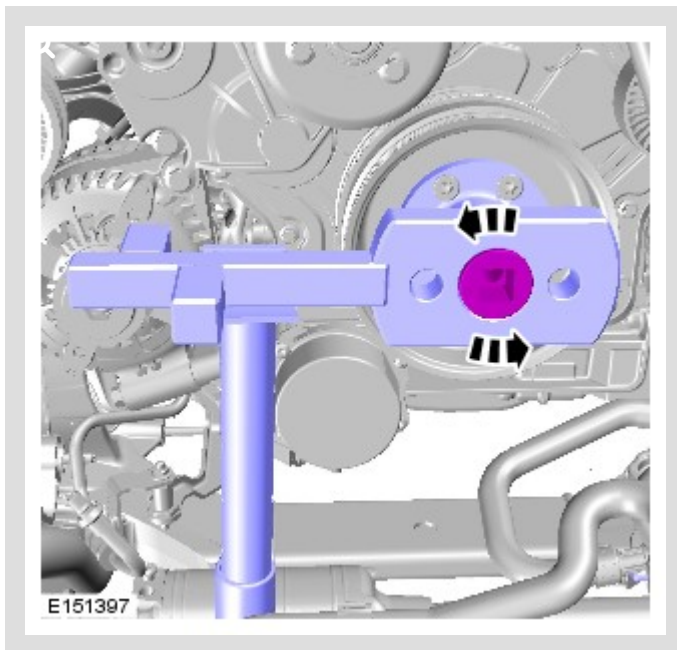

Tighten the center main crankshaft pulley bolt(s) in 2 stages. Make sure that the socket -- not the torque wrench -- is turned through 270°.

- Torque:
 - Stage 1: **200 Nm**
 - Stage 2: **270°**

15

ⓘ CAUTION:

Use care when removing the vehicle stand.

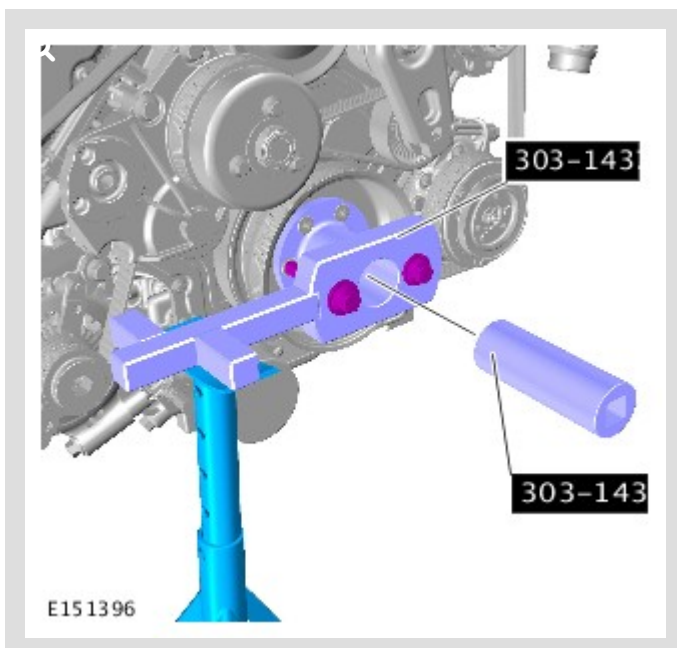

Remove the vehicle stand and special tools **303-1437** and **303-1438**.

16

 **NOTE:**

The original M10 bolt(s) can be reused.

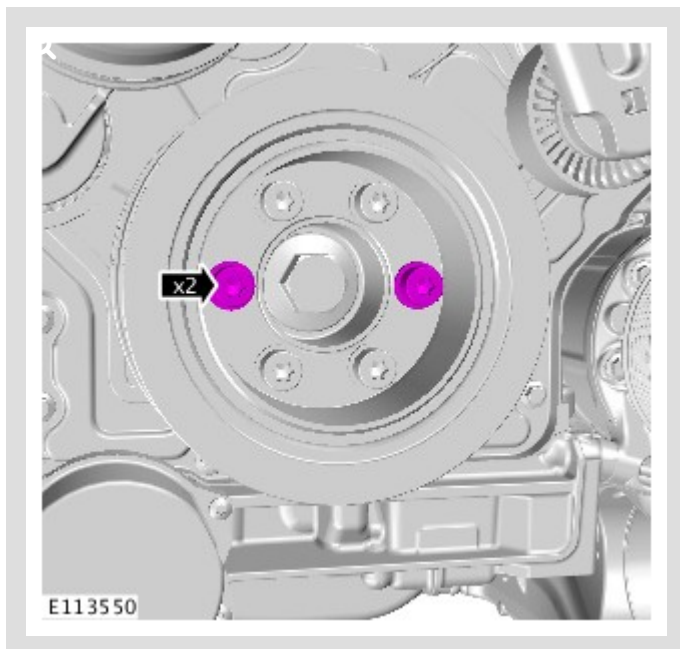

Install the 2 original outer crankshaft pulley bolt(s).

- 1 Clean the original outer crankshaft pulley bolt(s).
- 2 Apply Loctite 270 to the threads.
 - Torque: **65 Nm**

17

Install the engine undershield (see TOPIx Workshop Manual section 501-02: Front End Body Panels - Engine Undershield).

18

 **NOTE:**

Discovery, Range Rover Sport, Range Rover only.

Install the cooling fan and shroud (see TOPIx Workshop Manual section 303-03: Engine Cooling - Cooling Fan and Shroud).

- 1 When all tasks are finished, release the vehicle.

 **NOTE:**

Range Rover Velar only.

Install the radiator (see TOPIx Workshop Manual section 303-03: Engine Cooling - Radiator).

- 1 When all tasks are finished, release the vehicle.