

## IMPORTANT UPDATE

# TECHNICAL INSTRUCTIONS FOR SAFETY RECALL G0P/G0R/H0A FRONT PASSENGER AIRBAG INFLATOR MODULE CERTAIN 2011-2014 MODEL YEAR SIENNA

**Updated 1-9-2019**

**Update 1-9-19**

- Added 2014 MY
- Updated title to include G0R and H0A

**Update 7-17-18**

- The Technician Certification Requirements have changed

**Update 4-18-18**

- The parts section has been updated

**Update 1-9-18**

- Added 2013 MY

**Update 8-31-17**

- Added 2012 MY

**Update 6-19-17**

- Page 19 Unneeded Corolla/Matrix reference removed.

All dealership technicians performing this recall are required to successfully complete the most current version of the E-Learning course “Safety Recall and Service Campaign Essentials”. To ensure that all vehicles have the repair performed correctly; technicians performing this recall repair are required to have successfully completed E-Learning course SC18A (if you had previously completed E-Learning Course SC13B, you do not have to take SC18A), in addition to “Safety Recall and Service Campaign Essentials”, and currently hold at least one of the following certifications levels:

- Toyota Certified (Electrical)
- Toyota Expert (Any Specialty)
- Master
- Master Diagnostic Technicians

Always check which technicians can perform the recall remedy by logging on to <https://www.uotdealerreports.com>. It is the dealership’s responsibility to select technicians with the above certification level or greater to perform this repair. Carefully review your resources, the technician skill level, and ability before assigning technicians to this repair. It is important to consider technician days off and vacation schedules to ensure there are properly trained technicians available to perform this repair at all times.

## I. OPERATION FLOW CHART

The flow chart is for reference only. **DO NOT** use it in place of the full technical instructions. Follow **ALL** steps as outlined in the full technical instructions to confirm the campaign is completed correctly.

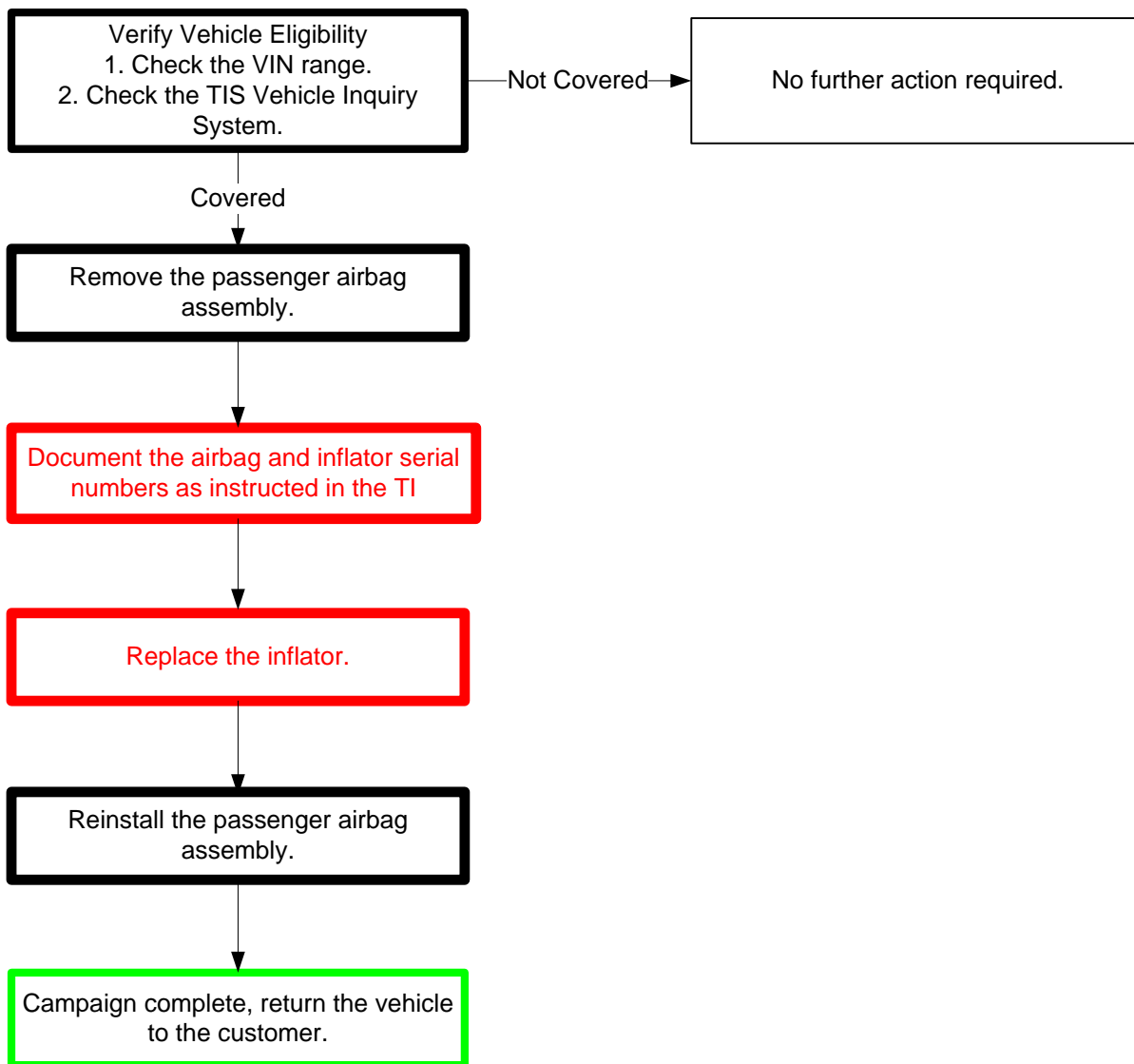

## II. BACKGROUND

The subject vehicles are equipped with front passenger airbag inflators produced by Takata. The propellant in these inflators may degrade after prolonged exposure to high absolute humidity and fluctuating high temperatures. Degraded propellant can cause inflator rupture during airbag deployment. In the event of an inflator rupture, metal fragments could pass through the airbag cushion material, striking the vehicle occupants, and result in serious injury or death.

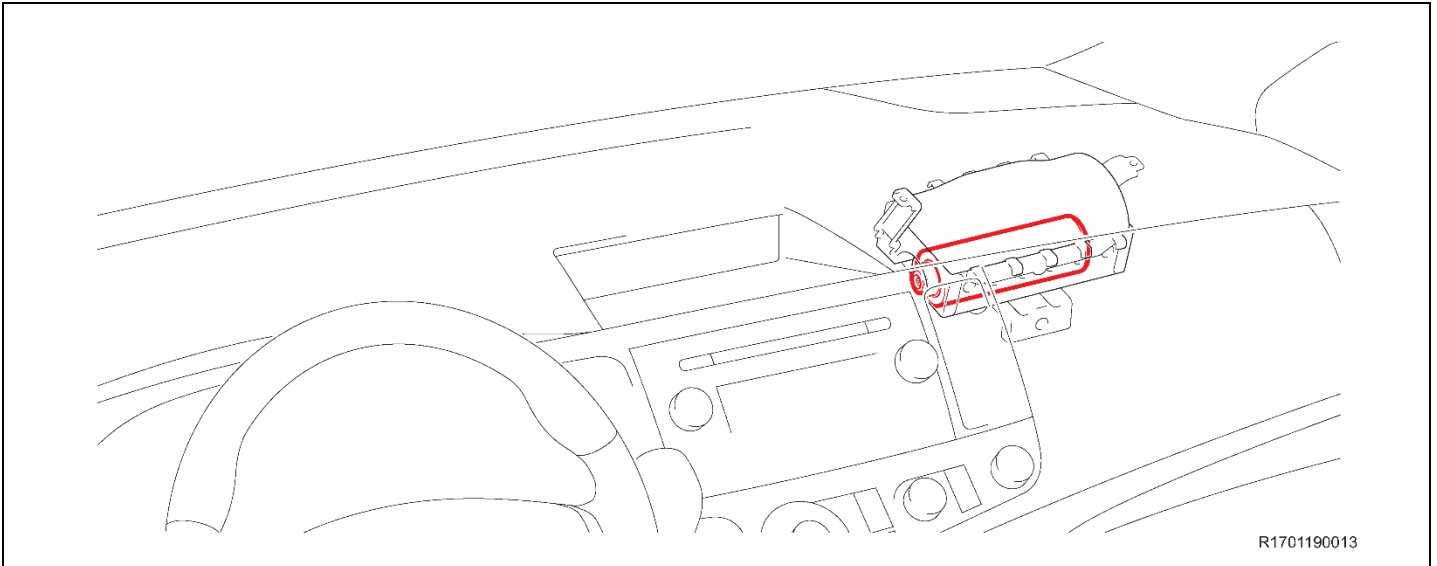

## III. IDENTIFICATION OF AFFECTED VEHICLES

- Check the TIS Vehicle Inquiry System to confirm the VIN is involved in this Safety Recall, and that the campaign has not already been completed prior to dealer shipment or by another dealer.
- **TMS warranty will not reimburse dealers for repairs conducted on vehicles that are not affected or were completed by another dealer.**

## IV. PREPARATION

### A. PARTS

Part Number	Part Description	Quantity
04007-06645	Instrument Panel Airbag Inflator Kit*	1
*The kit above includes the following parts.		
	Inflator	1
	Self Locking Nut	5
	Position Determining Plate	1

Part Number	Part Description	Quantity
62217-06010	Front Pillar Garnish Clips	2
<b>NOTE: The front garnish clips require replacement although the repair manual states they are reusable.</b>		

## Non-Desiccated Part Recovery

*Dealers should discontinue the installation of the non-desiccated parts listed below for recall, customer pay repairs **AND** over-the-counter sales (if applicable).*

Model	Model Year	Part Number	Part Description
Sienna	2011-2014	73960-08050 73960-08060	AIR BAG ASSY, INSTR PNL PASS L/DOOR

**Toyota requires all dealers to return any parts listed above that still remain in dealer inventory by utilizing the Hazmat Part Return Program available. Dealers will be issued a refund for all part returns. This part return program is outlined in *PANT Bulletin 2014-042*.**

### Important Note:

In order to return the inflator, packages must **NOT** be opened/tampered with.

**B. TOOLS & EQUIPMENT**

- Standard hand tools
- Torque wrench
- Techstream
- Molding remover set

**D0F CAMPAIGN TOOLS** – These tools were previously provided to the dealership for campaign D0F. These tools are required when performing this repair.

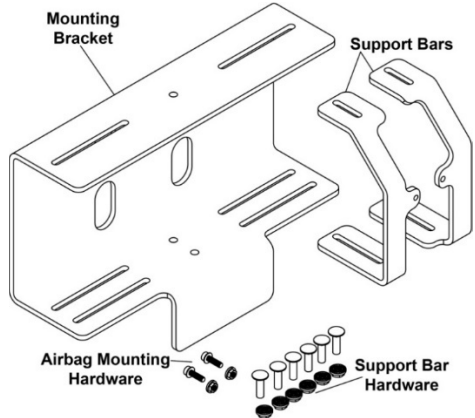
Image	Name	Quantity
	Airbag Mounting Bracket & hardware	1

**SST** – These are essential service tools that the dealership should have.

Part Number	Part Name	Quantity
09950-50013	Puller C Set *	1
* The set above includes the following tools.		
Part Number	Part Name	Quantity
09951-05010	Hanger 150	1
09952-05010	Slide Arm	2
09953-05020	Center Bolt 150	1
09954-05070	Claw No. 7	2

**OPTIONAL SST** – This is an essential special service tool that the dealership should have. However, this tool is not mandatory when performing this repair.

Part Number	Part Name	Quantity
09890-47010-01	Anti-Static Mat Set	1

**F0J CAMPAIGN TOOLS** – This tool was provided to the dealership for campaign F0J and will be used for this campaign also. This tool is required when performing this repair.

**NOTE: The scanner for F0J must be used, because it has the capability to scan bar and QR codes.**

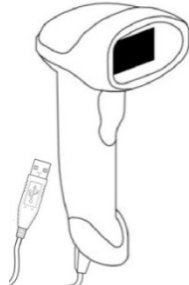
Image	Name	Quantity
	Barcode Scanner	1

**NOTE: This scanner CANNOT be ordered through the parts or tools system. If additional scanners are needed, they can be sourced locally.**

## V. COMPONENTS

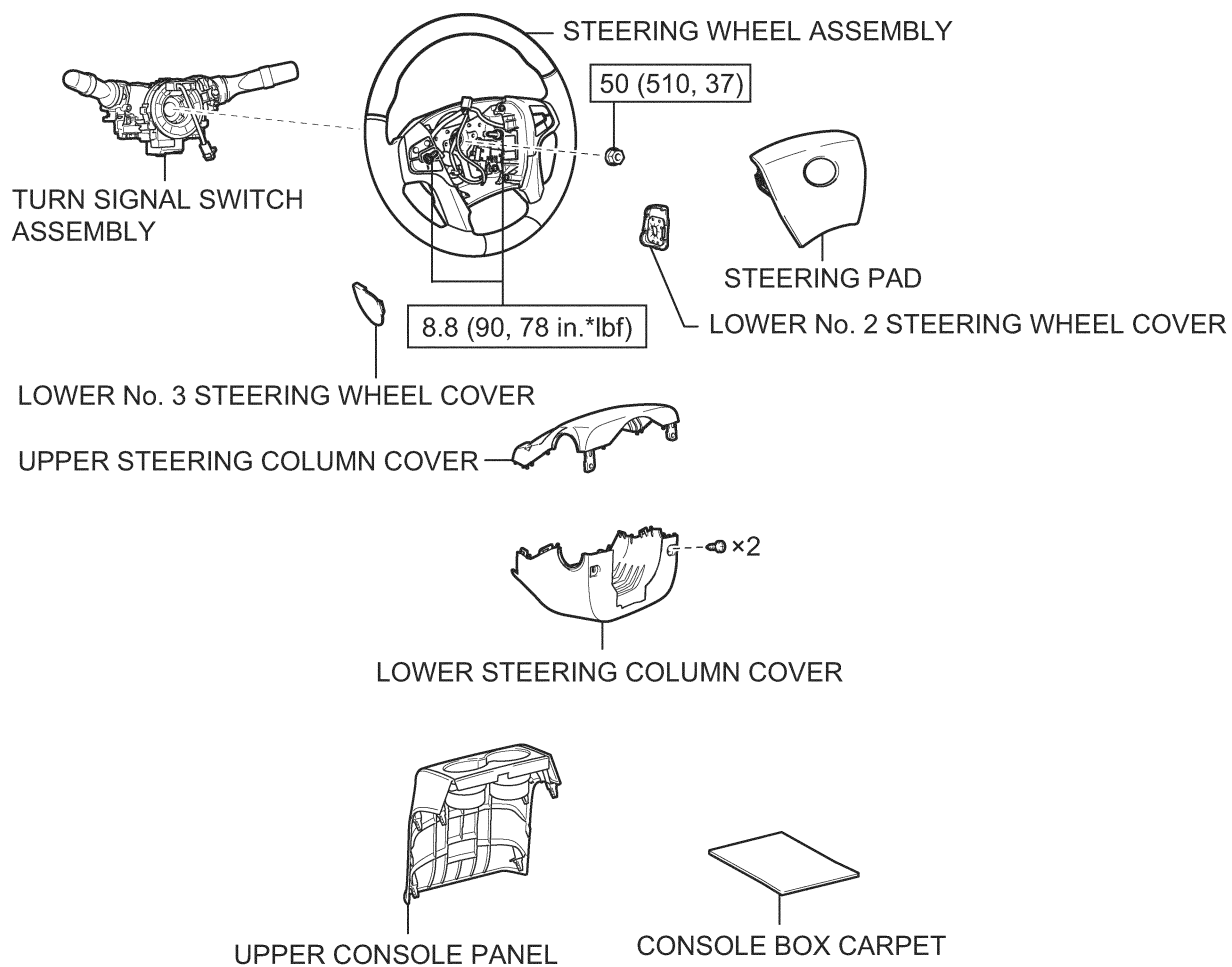

【for Fixed Type】

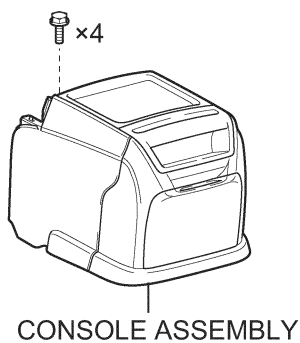

【for Slide Type】

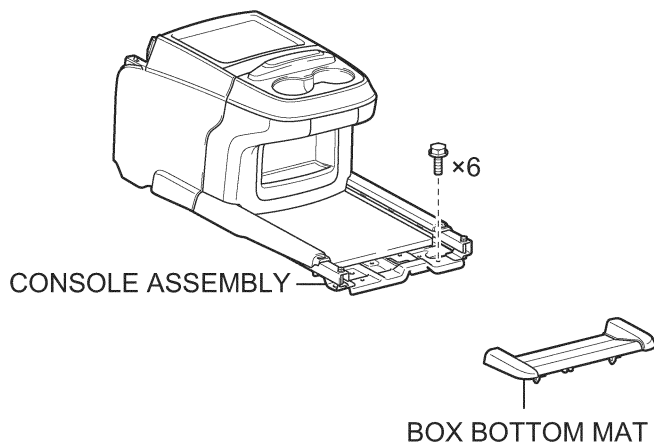

**N\*m (kgf\*cm, ft.\*lbf)** : Specified torque

R1701060003

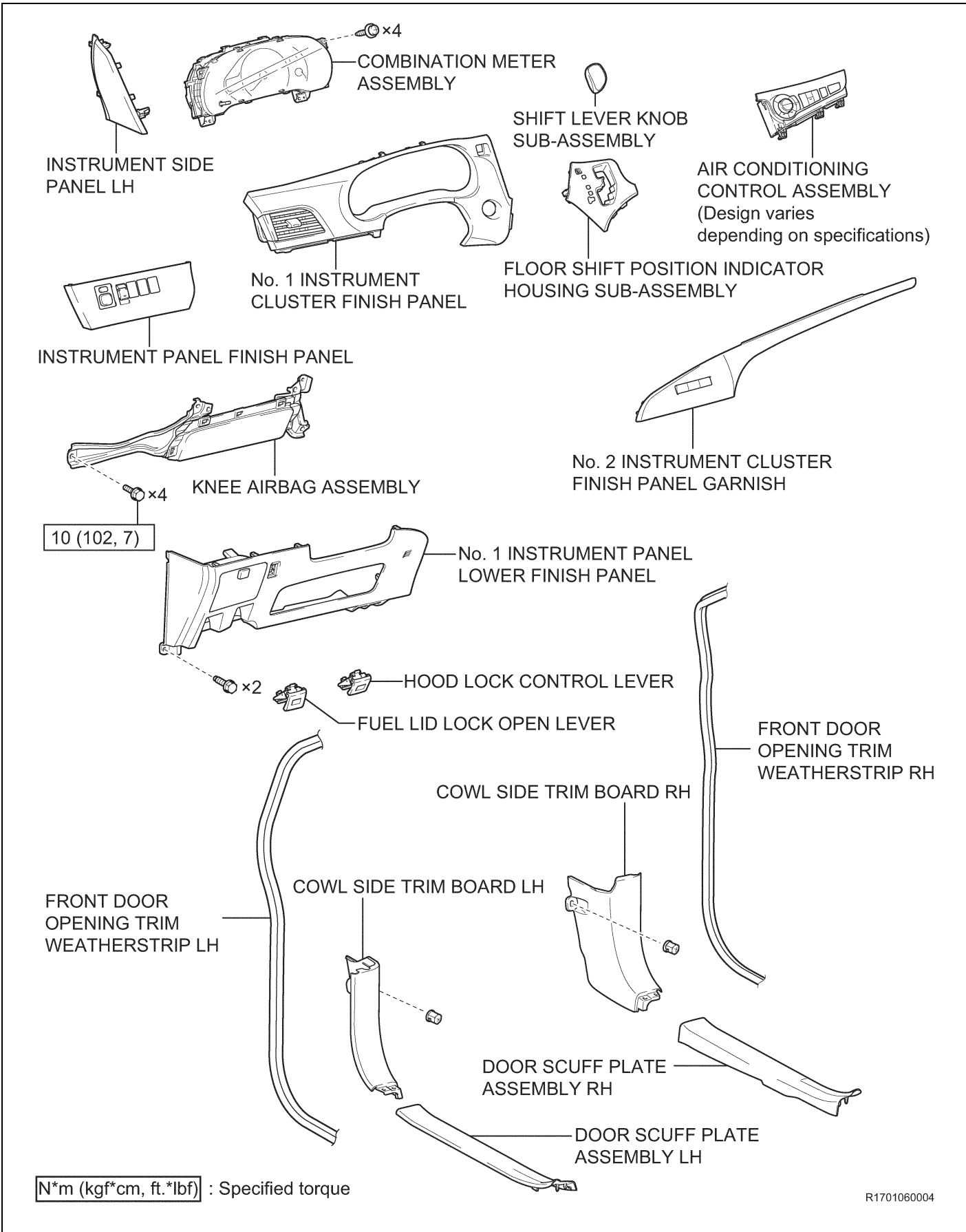

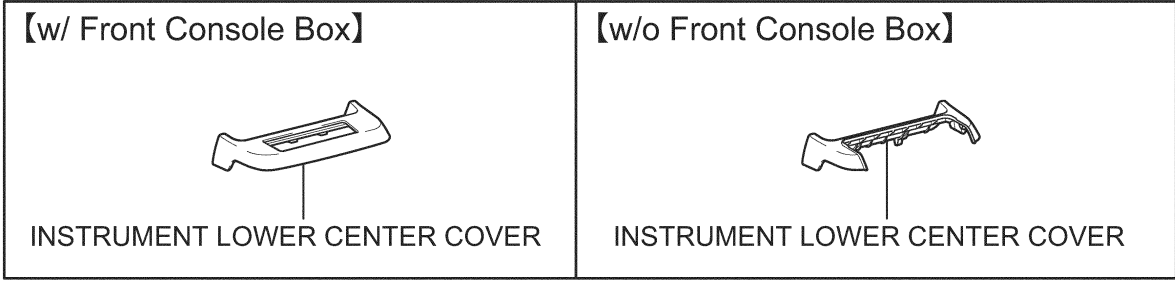
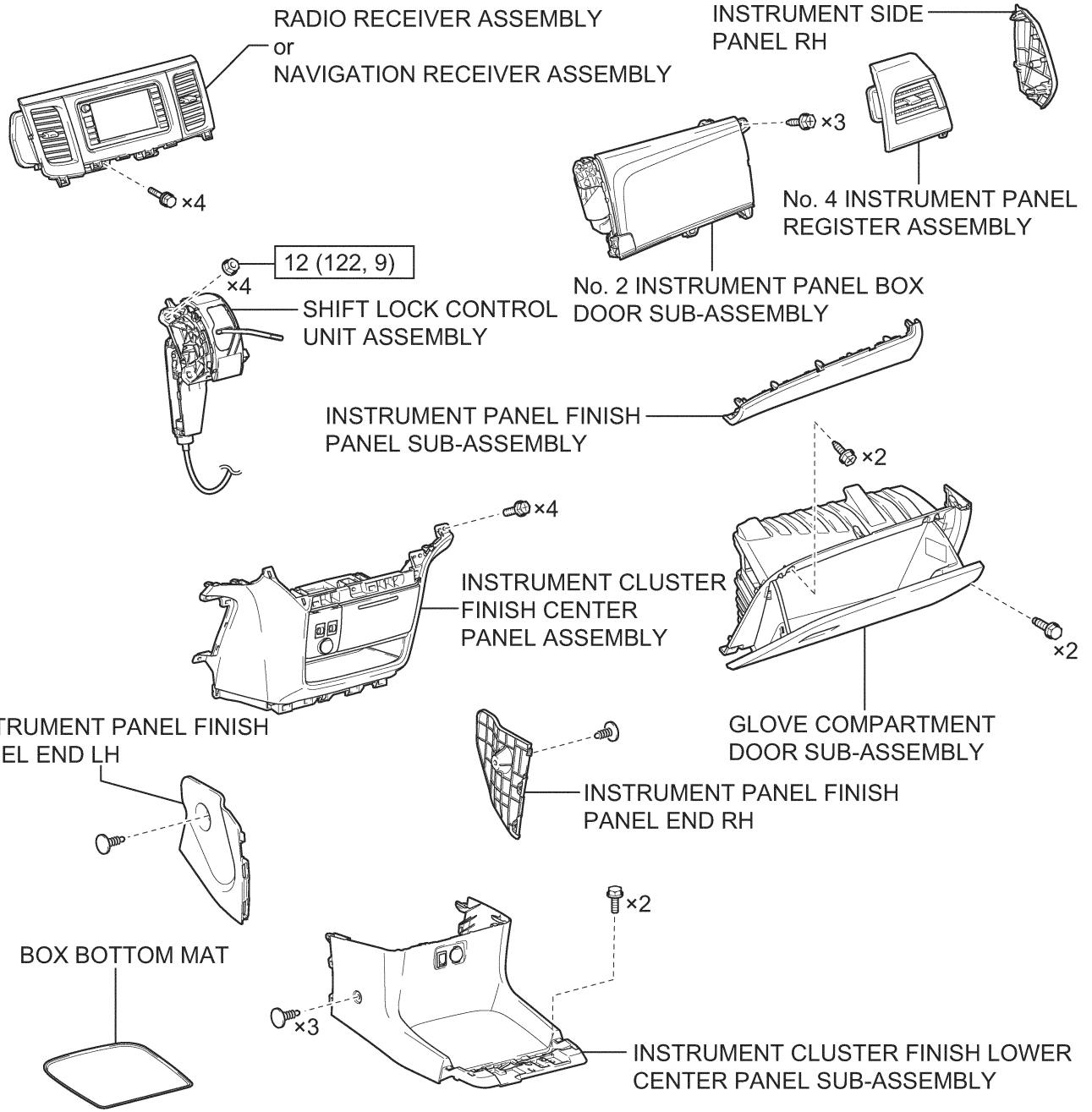

**N\*m (kgf\*cm, ft.\*lbf)** : Specified torque

R1701060005



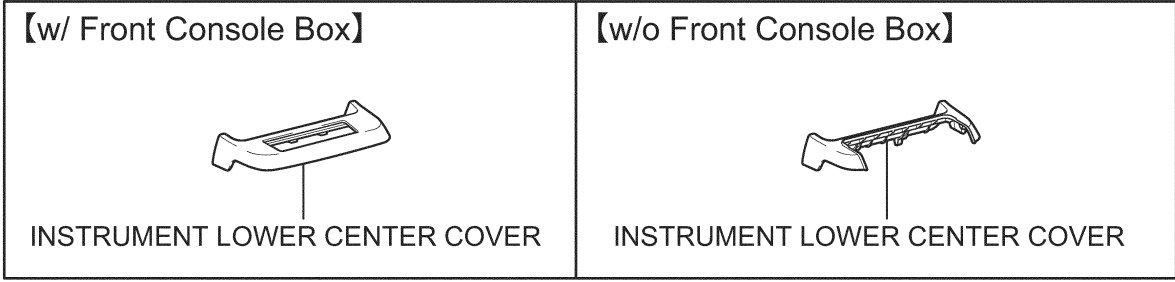
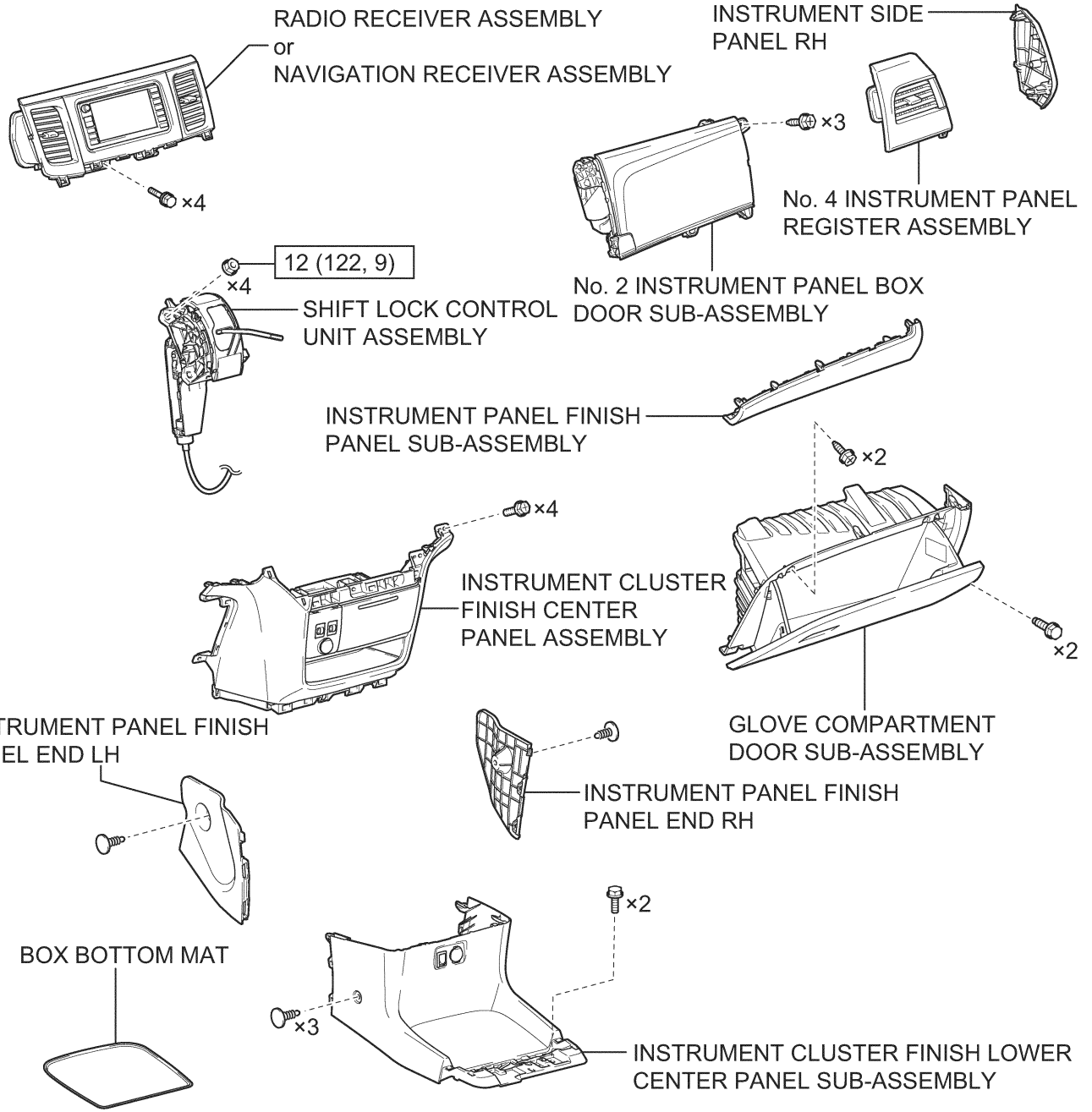

**N\*m (kgf\*cm, ft.\*lbf)** : Specified torque

R1701060005

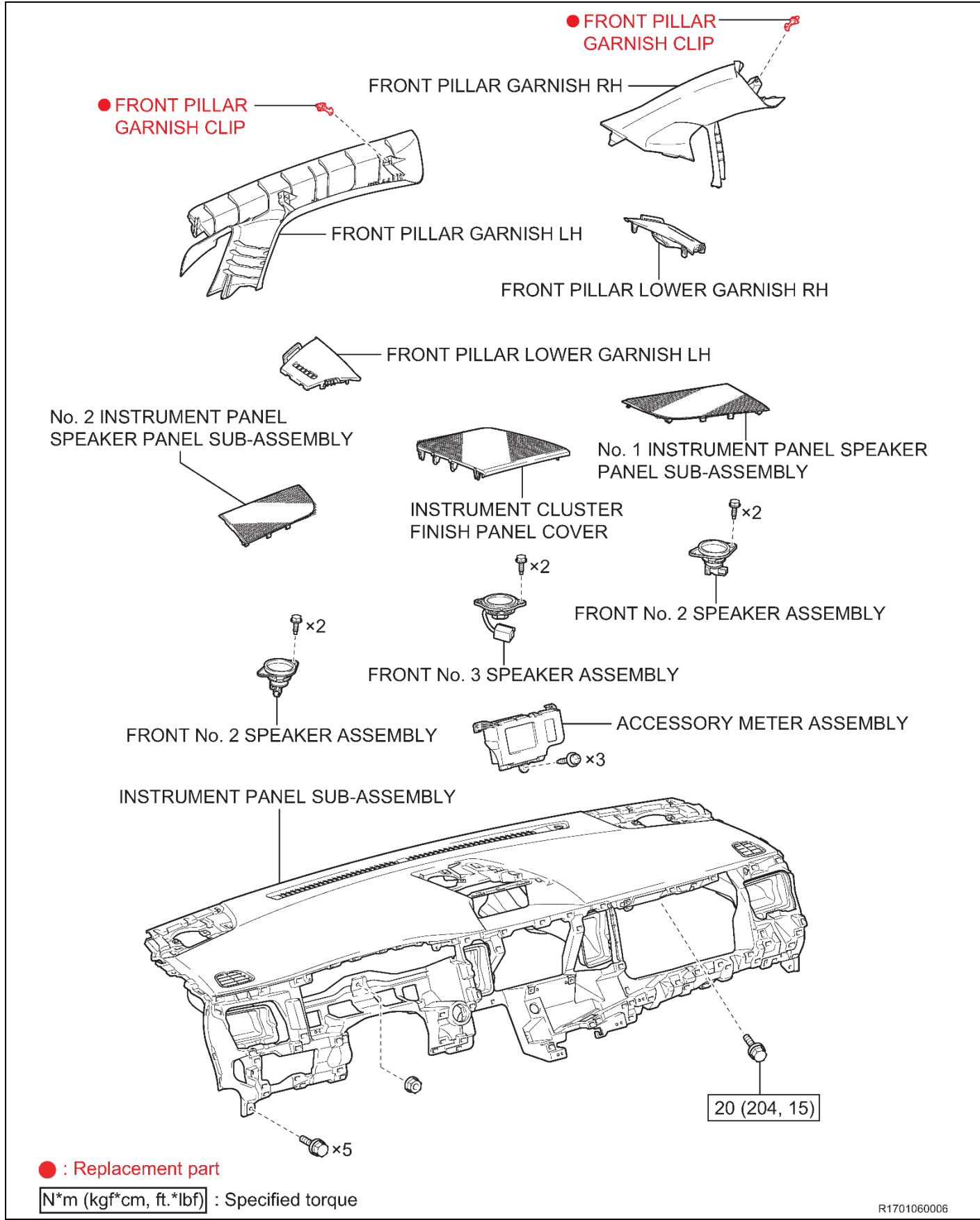

INSTRUMENT PANEL PASSENGER AIRBAG ASSEMBLY

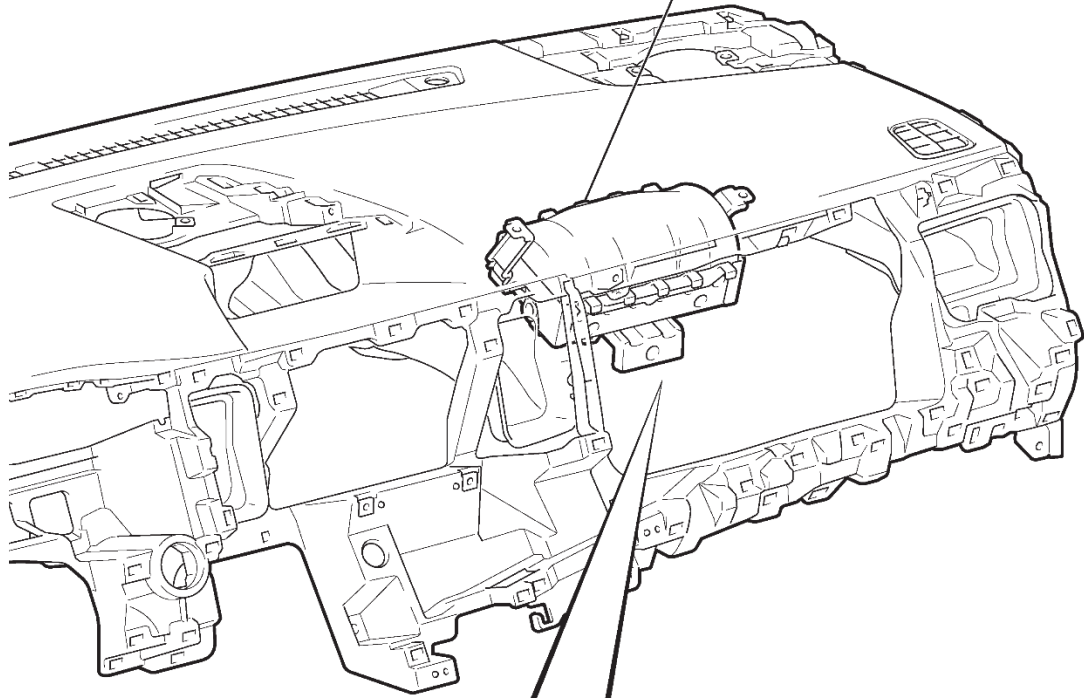

**3.9 N·m (40, 35 in.\*lbf)**  
**Be careful not to overtighten.**

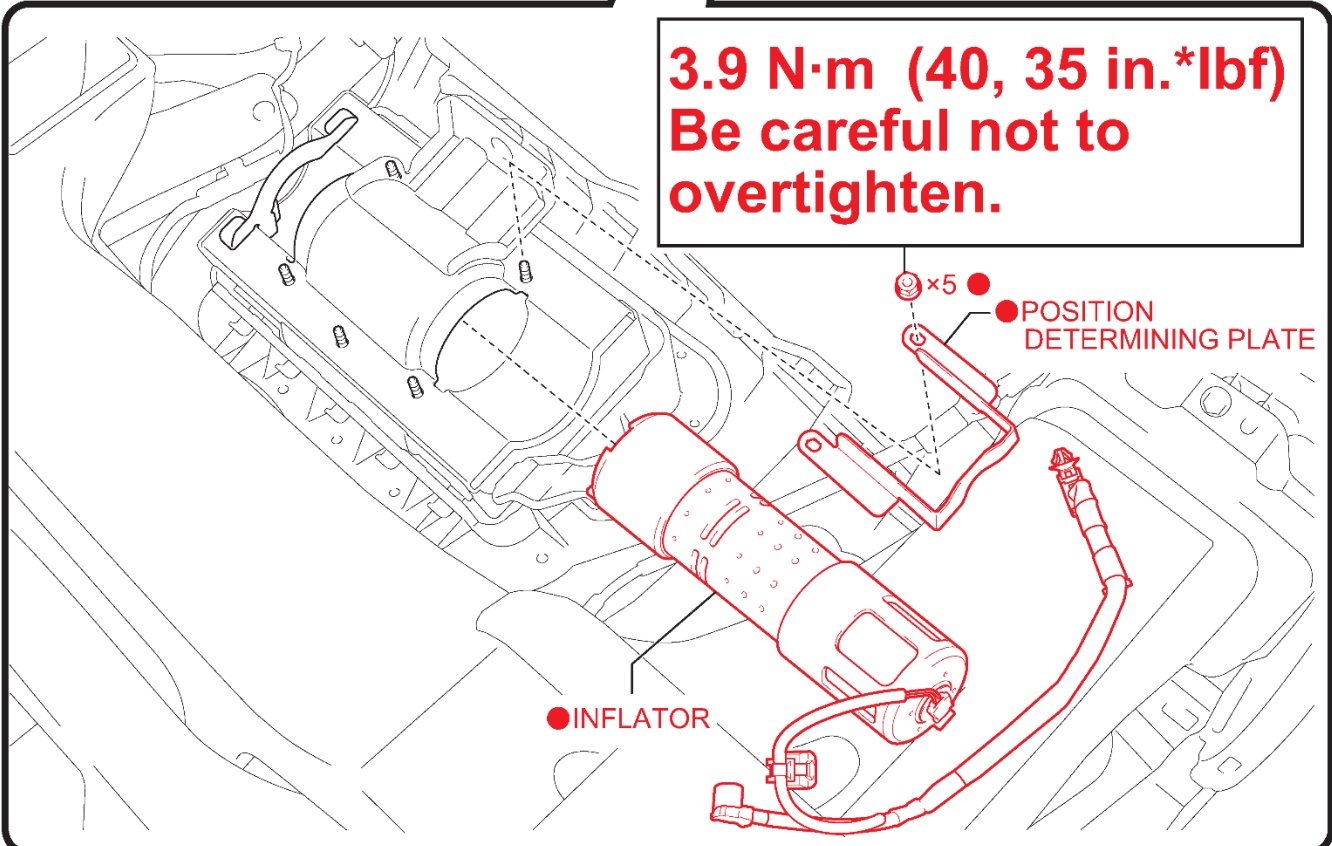

● x5  
● POSITION DETERMINING PLATE

● INFLATOR

● : Replacement part

R1701280028H

## VI. SAFETY PRECAUTIONS



### CRITICAL INFORMATION – READ THOROUGHLY



Failure to follow these procedures correctly could cause the SRS to unexpectedly deploy during servicing or the SRS may fail to operate correctly when required after reassembly. Confirm all work is performed as described in these instructions.

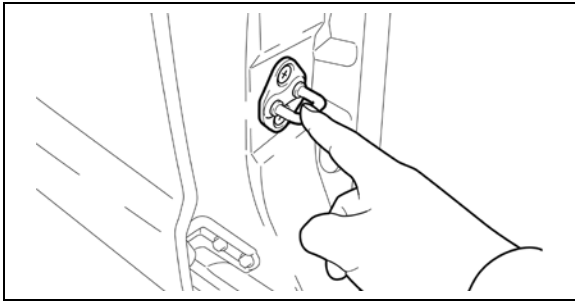

#### 1. ELIMINATE STATIC ELECTRICITY

- a) Before starting work and periodically while working on the vehicle, touch a metallic part of the vehicle to discharge static electricity in the body.

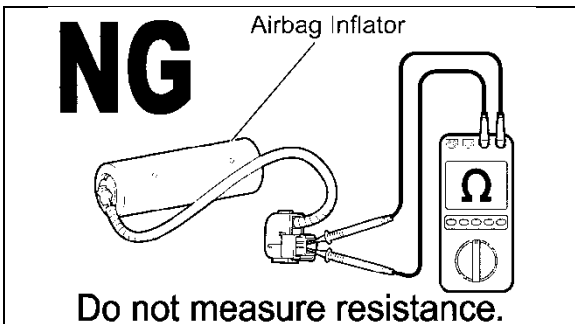

#### 2. DO NOT MEASURE RESISTANCE

- a) **DO NOT** measure resistance of airbag components, this may cause accidental activation.

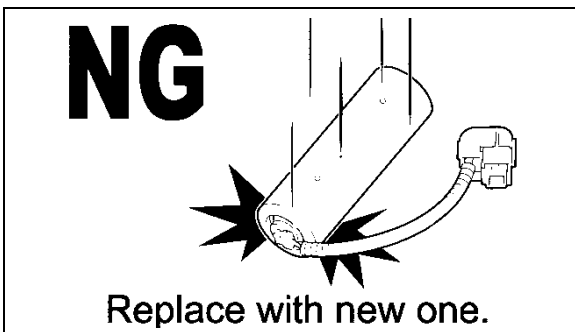

#### 3. HANDLE THE AIRBAG CAREFULLY

- a) If an inflator is dropped, replace it with a **NEW** inflator.

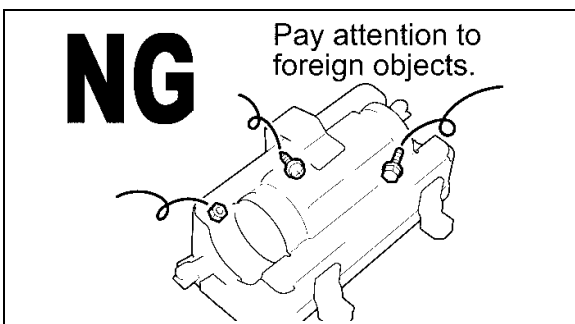

#### 4. DO NOT ALLOW FOREIGN OBJECTS NEAR AIRBAG

- a) Be sure to collect and account for all removed nuts/bolts to prevent them from landing in the airbag assembly.
- b) Any foreign objects in the airbag assembly may cause damage or injury if the airbag is activated.

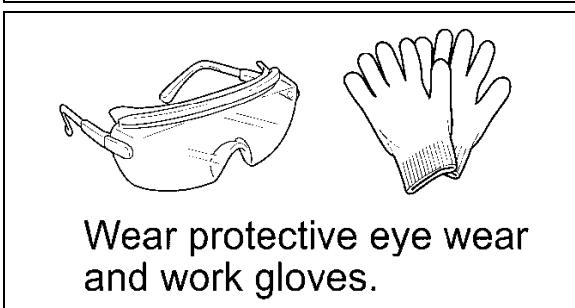

#### 5. WEAR PROTECTIVE EQUIPMENT

- a) Always wear appropriate protective equipment when working on the SRS.

## VII. SRS SYSTEM HEALTH CHECK

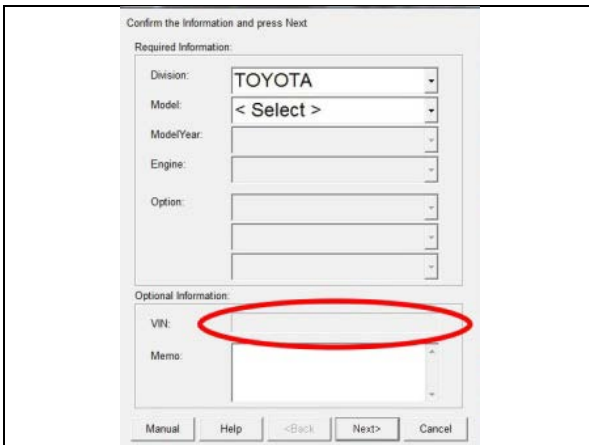

### 1. PERFORM A HEALTH CHECK

- Confirm the Techstream is connected to the dealership's internet.
- When launching the Techstream software the VIN **MAY NEED** to be entered manually depending upon model year.

**NOTE: All letters of the VIN *MUST* be entered in ALL CAPS, or the VIN will need to be reentered when running the diagnostic report.**

- Perform a health check.



- The VIN **MAY NEED** to be entered manually in ALL CAPS when launching the Techstream software, the VIN **MAY OR MAY NOT** auto-populate due to model year.
- The serial number recording application will be disabled and the repair cannot be completed if a health check and diagnostic report is not performed and recorded by TMNA.

## VIII. WORK AREA PREPARATION



### CRITICAL INFORMATION – READ THOROUGHLY



The anti-static mat set that is an essential SST may be available at your dealership and is optional to use during inflator replacement. If the anti-static kit is not available, before starting work and periodically while working on the vehicle, touch a metallic part of the vehicle to discharge static electricity in the body.

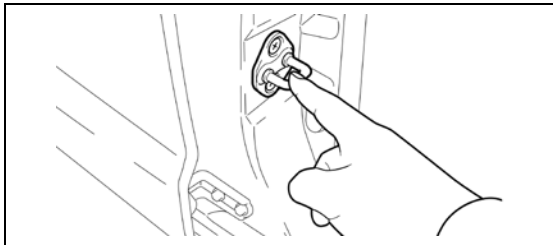

If the anti-static kit is not available, before starting work and periodically while working on the vehicle, touch a metallic part of the vehicle to discharge static electricity in the body.

## IX. PASSENGER AIRBAG INFLATOR REPLACEMENT

### 1. REMOVE THE AIRBAG ASSEMBLY



- Wait at least 90 seconds after disconnecting the cable from the negative battery terminal to prevent airbag and seat belt pre-tensioner deployment.
- Follow all precautions as outlined on TIS before servicing the SRS system.

a) Refer to TIS for instructions on airbag removal:

[2011 MY](#) [2012 MY](#) [2013 MY](#) [2014 MY](#)

### 2. LAUNCH THE SERIAL NUMBER RECORDING APPLICATION



- The AIRBAG ASSEMBLY, ORIGINAL INFLATOR, and NEW INFLATOR serial numbers **MUST** be recorded using the barcode scanner (provided at the launch of SSC F0J).
- The barcode scanner application **MUST** be completed on every vehicle. These numbers **MUST** be included on every warranty claim that is submitted for inflator module replacement or the claim may be subject to debit.
- The technician performing the work **MUST** have valid TIS login credentials and an internet connection to perform the inspection and scanning process.

a) Log in to TIS and input the VIN of the vehicle in the Vehicle Inquiry tab.

b) Confirm the VIN is applicable and that the campaign has not been completed.

c) Click on the link to launch the serial number recording application.

The screenshot displays the Toyota TIS Vehicle Inquiry interface. At the top, there are navigation tabs for Home, TIS, TAS, PRS, and QAT. Below these are sub-tabs for Library, Diagnostics, Tech Assistance, and Vehicle Inquiry. The main content area is titled 'Vehicle Identification Number Search' and contains a search form with the VIN '1NX-BR32E-000000000' entered. A red circle highlights the VIN input field, with a red 'a)' next to it. Below the search form is a 'Vehicle Information' section with a table of details: Division: TOYOTA, Model: Corolla, Grade: CE, Model Year: 2003; Drive Type: 2WD, Body Type: 4Dr. Sedan, Engine Family: 4-cylinder - 1ZZ, Transmission: ; Date of First Use: , Production Date: 01/18/2002, Plant Code: Z - FREMONT PLANT - NUMM; VIN: 1NX-BR32E-000000000, Standard Equipment: Click here to display; Exterior Color: 03MS, SANDRIFT METALLIC, Interior Color: FA41, FA41, Interior Trim Color: FA, \*, Interior Fabric: F, \*. Below this is a 'Service Campaigns' section with a table showing a campaign description: 'Safety Recall DCF Remedy Notice - 2003-2004 Model Year Corolla, Corolla Matrix, Sequoia, and Tundra Vehicles, 2002-2003 Model Year'. The completion status is 'Not Complete' and there is a link 'Check applicability for VIN' circled in red with a red 'c)' next to it. A red 'b)' is also present near the completion status. The footer of the page includes '© 2013 Toyota Motor Sales, Inc.' and links for Feedback, Privacy, and Legal.

d) Reenter TIS password in the serial number recorder application.

**NOTE:** The person logged-in to TIS **MUST** be the person performing the repair.



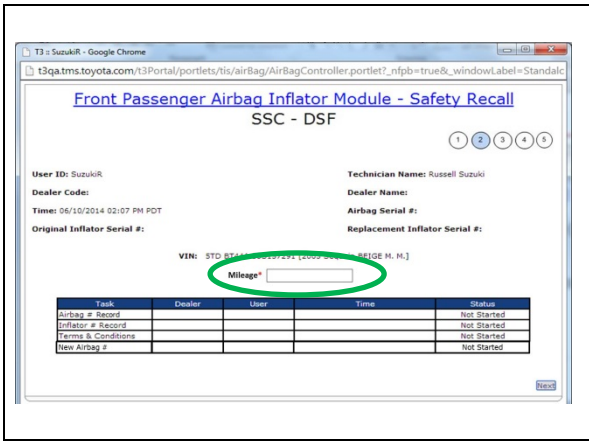

- e) Record the vehicle mileage into the serial number recording application.

**NOTE:**

- A task status screen will populate next and at other intervals during the repair. This screen will indicate if the inflator was replaced or in some limited cases that the entire airbag assembly was replaced. Click 'next' to proceed to the next step. This information will be used for record keeping by TMNA.
- If this screen indicates that the inflator has already been replaced on this VIN, there is no need to perform the campaign again.

**3. CONNECT THE BARCODE SCANNER**

- Connect the barcode scanner to the USB port on the Techstream.
- The scanner will automatically connect and a beep will be heard when the scanner is ready.

**NOTE:**

- Use the scanner that was provided for SSC F0J. The scanner for F0J is needed due to its ability to read bar and QR codes.
- The scanner works best in low light conditions.
- Always hold the scanner directly in front of and parallel to the barcode label.

**4. SCAN THE AIRBAG SERIAL NUMBER**

- Scan the **AIRBAG ASSEMBLY** serial number 2 times.
  - Confirm the cursor is in the first serial number box then scan the serial.
  - Position the cursor in the second serial number box then scan the serial.
- Click next.

**NOTE:**

- If both serial numbers that are entered do not match, confirm and reenter.
- If the serial number barcode will not scan, it can be entered manually.

**AIRBAG SERIAL NUMBER IDENTIFICATION**

- The airbag serial number is **ALWAYS** the 12 **DIGITS** located between the asterisks.
- The 3 digits before the asterisk **ARE NOT** part of the serial number, and **SHOULD NOT** be entered or an inaccurate response may be returned.

**Airbag Serial Number Label Example**



The **AIRBAG ASSEMBLY** serial number and the **INFLATOR** serial number are **DIFFERENT**. The **AIRBAG ASSEMBLY** serial number **MUST** be recorded prior to replacement.

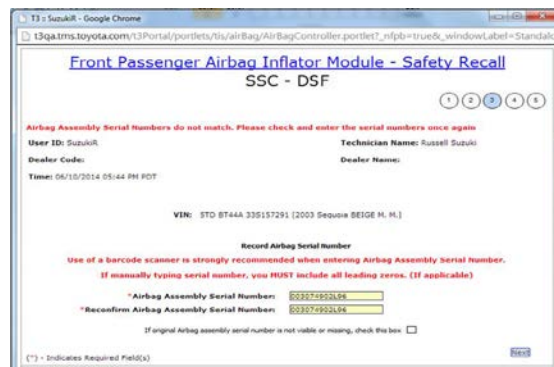
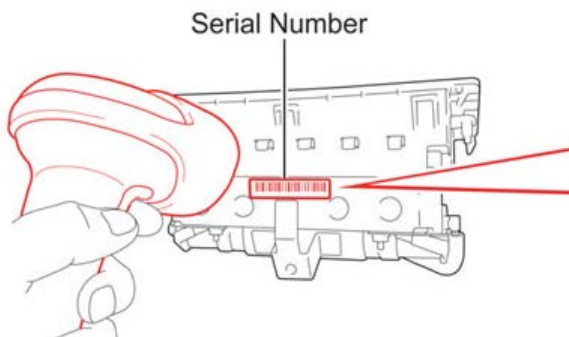

## AIRBAG SERIAL NUMBER IS MISSING OR IS UNREADABLE



If the airbag serial number and barcode are not legible or are not present, check the box in the application indicating the serial number is not legible and contact your regional representative.

- a) If the airbag serial number is unreadable or not present check the box as shown below.

Front Passenger Airbag Inflator Module - Safety Recall  
SSC - DSF

1 2 3 4 5

User ID: SuzukiR Technician Name: Russell Suzuki  
Dealer Code: Dealer Name:  
Time: 06/12/2014 03:43 PM PDT

VIN: 1NX BR32E 00000000 (2003 Corolla, Beige)

**Record Airbag Serial Number**

Use of a barcode scanner is strongly recommended when entering Airbag Assembly Serial Number.  
If manually typing serial number, you MUST include all leading zeros. (If applicable)

\*Airbag Assembly Serial Number:   
\*Reconfirm Airbag Assembly Serial Number:

If original Airbag Assembly serial number is not visible or missing, check this box:

Please contact Region for further information

(\*) - Indicates Required Field(s)

Back Next

- b) After the Region approves the Airbag Assembly replacement and the new part is received, record the NEW airbag serial number in the Serial Number Recording Application.

Front Passenger Airbag Inflator Module - Safety Recall  
SSC - DSF

1 2 3 4 5

User ID: SuzukiR Technician Name: Russell Suzuki  
Dealer Code: Dealer Name:  
Time: 06/12/2014 03:43 PM PDT

VIN: 1NX BR32E 00000000 (2003 Corolla, Beige)

**Record Airbag Serial Number**

Use of a barcode scanner is strongly recommended when entering Airbag Assembly Serial Number.  
If manually typing serial number, you MUST include all leading zeros. (If applicable)

\*New Airbag Assembly Serial Number:

(\*) - Indicates Required Field(s)

Next



The new **AIRBAG ASSEMBLY** serial number **MUST** be recorded prior to reinstallation to track the airbag assembly to the vehicle.



# X INFLATOR REPLACEMENT

## 1. WORKING WITH AN AIRBAG

a) Carefully place the airbag on the bench inflator side up.

**NOTE: Place clean sheet(s) of paper on the bench to protect the airbag.**

b) Avoid standing directly over the inflator.

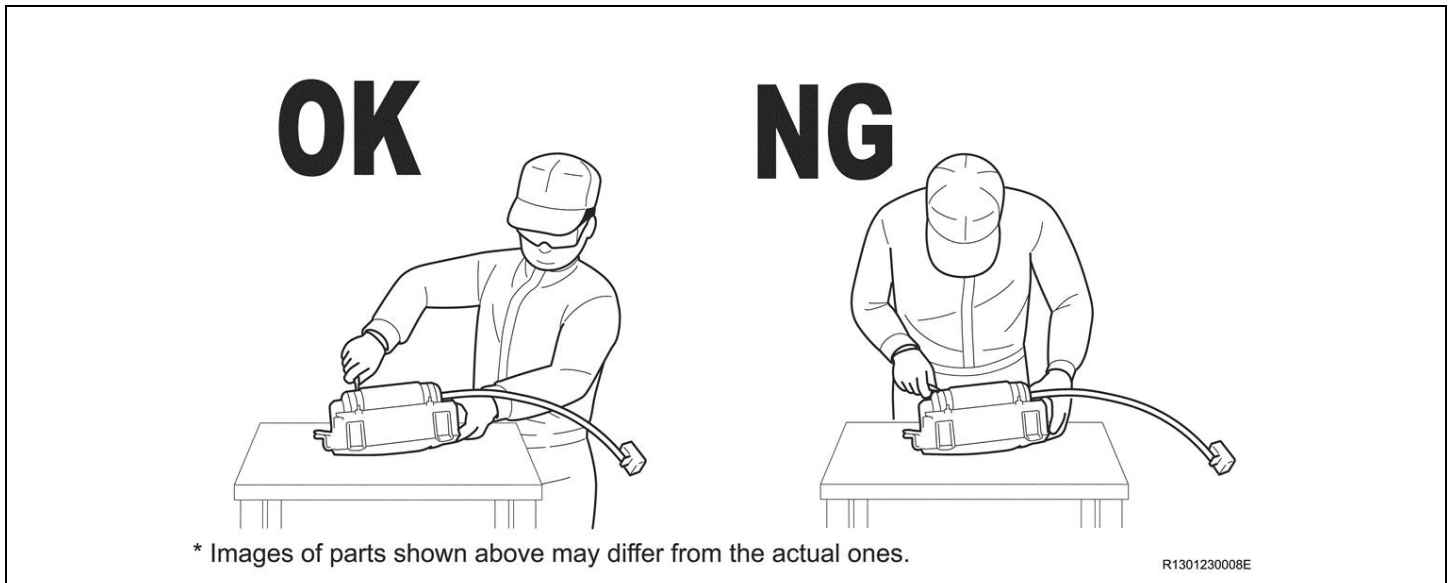

**STOP**

**CRITICAL INFORMATION – READ THOROUGHLY**

**STOP**

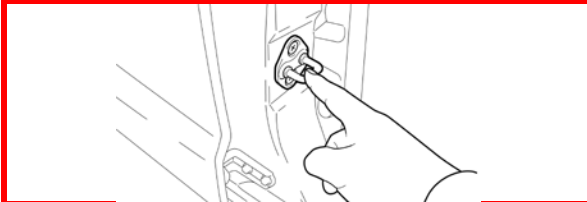

**Remember to periodically touch a metallic part of the vehicle to discharge static electricity in the body if the anti-static kit is not being used.**

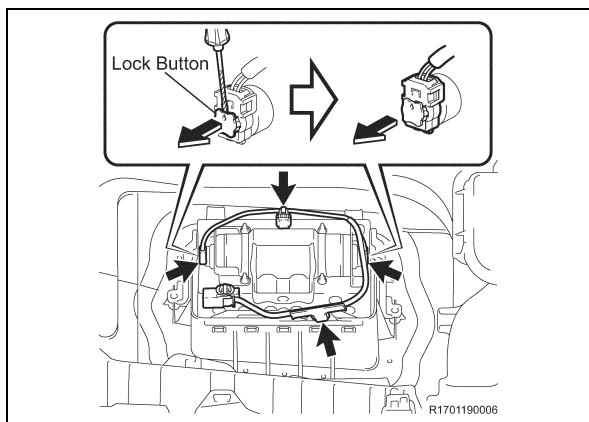

## 2. AIRBAG PREPARATION

- Use a screwdriver to release the lock button on each end of the inflator.
- Disconnect both connectors.
- Disconnect the 2 wire harness clamps.
- Remove and discard the harness.

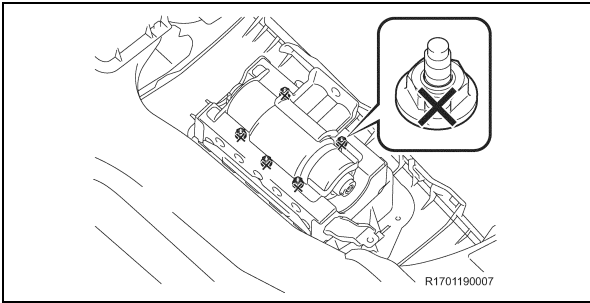

e) Mark all 5 nuts so they will not be reused.

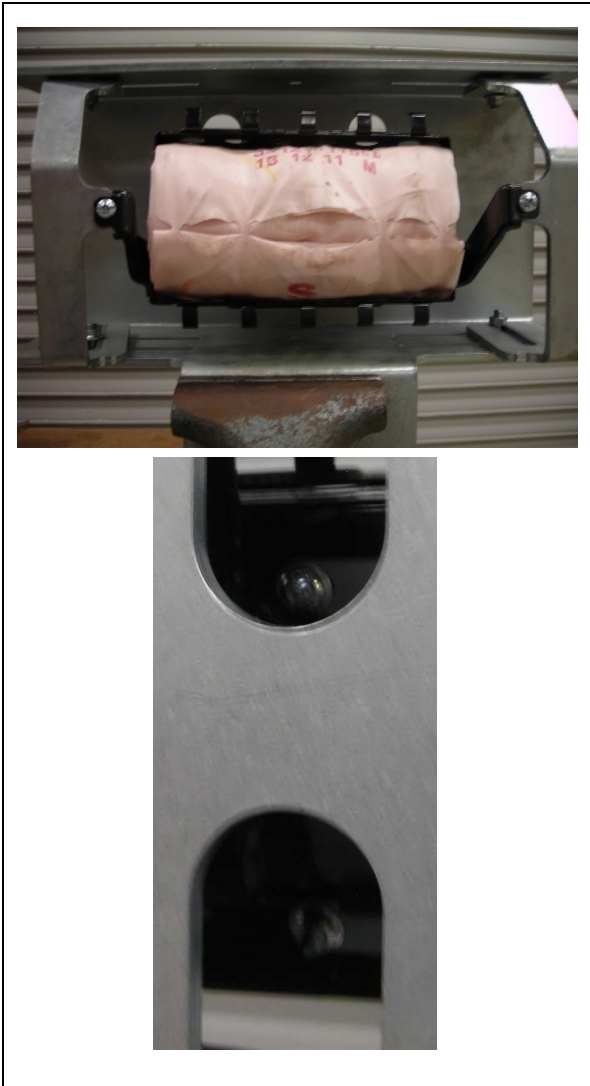

f) Mount the airbag into the mounting bracket as shown.

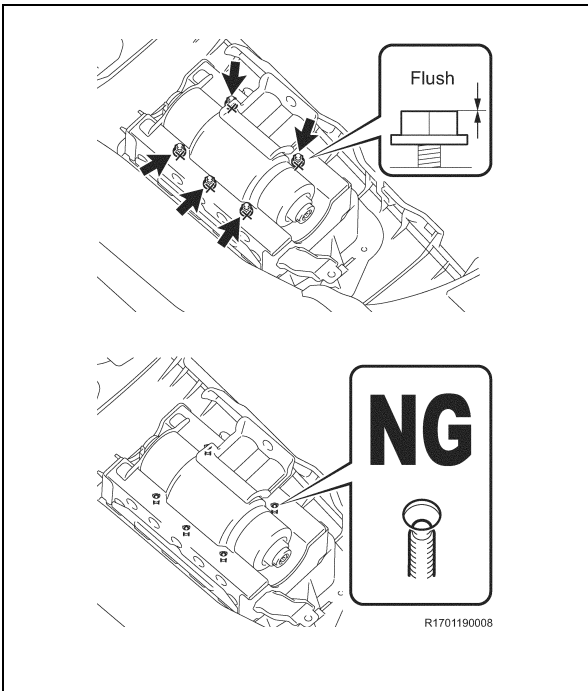

### 3. LOOSEN THE SELF-LOCKING NUTS

- a) Loosen the 5 nuts until the nuts are at the top of the studs as shown, through the openings in the mounting bracket.

**NOTE: Do not use power tools. It may be necessary to slide the airbag to the left or right to access the middle nut.**

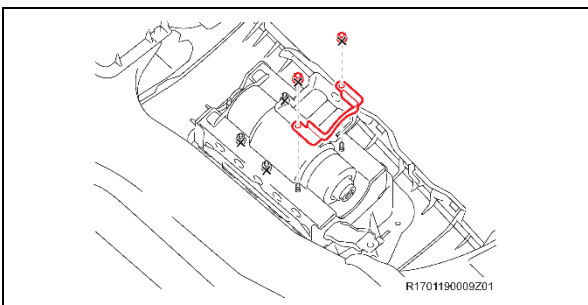

- b) Remove and discard the 2 nuts on the end where the bracket is removable.
- c) Remove the bracket and discard.

**NOTE:**

- **DO NOT** use power tools.

### 4. REMOVE THE INFLATOR

- a) Gently push the inflator in the direction shown.

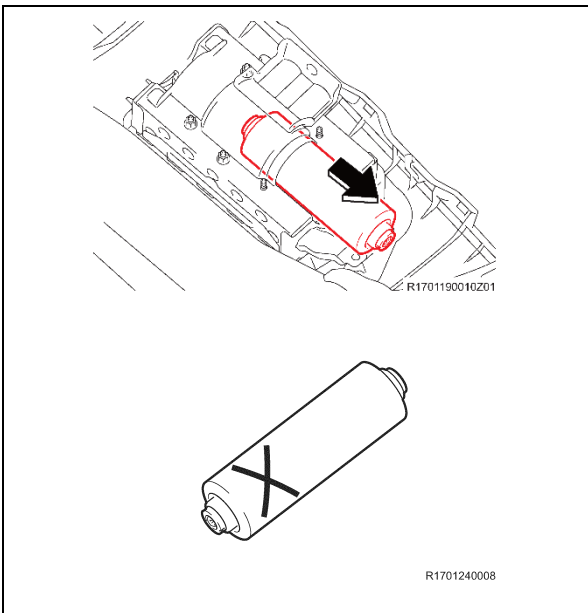

- b) Remove the inflator from the airbag assembly and place it on a safe work surface.
- c) Mark the old inflator so it is not reused.

**5. SCAN THE OLD AND NEW INFLATOR SERIAL NUMBER**

- a) Scan the **OLD** inflator bar code.
- b) Scan the **NEW** inflator QR code.

**NOTE: This information is CRITICAL**

- It is recorded by TMNA to trace the return parts shipment.
- It is used to track the new inflator that is being installed on the vehicle.

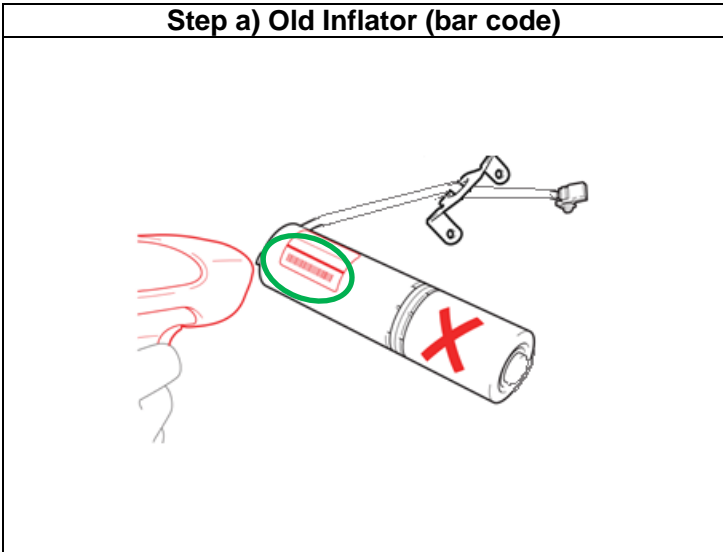

- c) Confirm agreement by checking the two boxes.
- d) Record the Warranty Authorization # to be included in the warranty claim.
- e) Place the old inflator in the parts box and return it immediately to the parts department.

**NOTE:**

- Confirm the cursor is in the correct serial number input box before scanning.
- If the serial number barcode will not scan, it can be entered manually.
- If there are any difficulties or concerns with this process, email [quality\\_compliance@toyota.com](mailto:quality_compliance@toyota.com) with details.

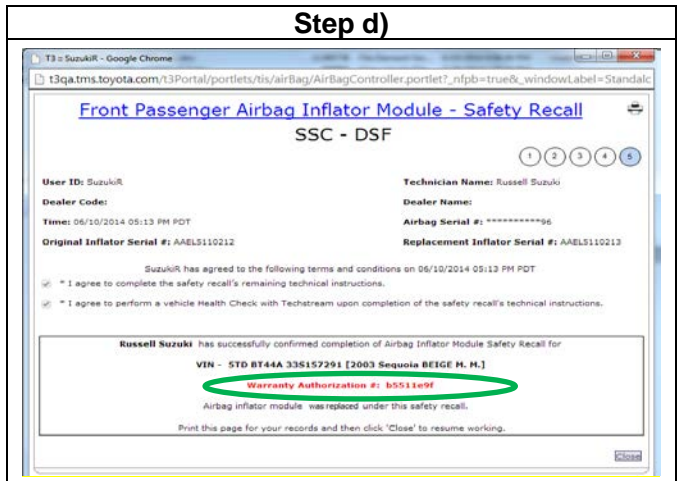
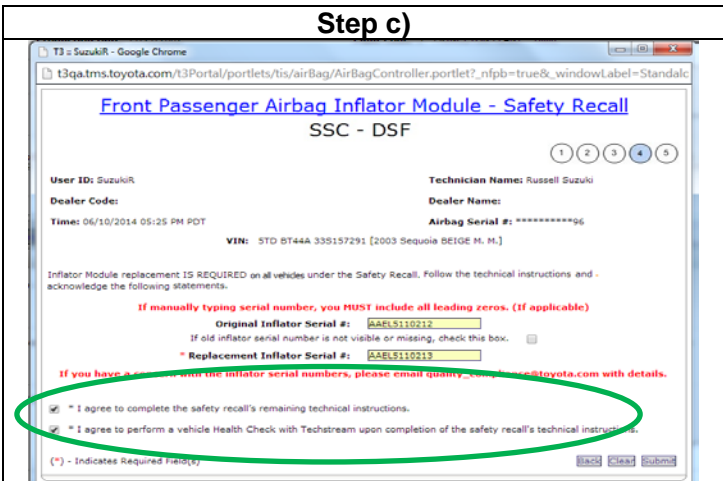

## 6. INSTALL THE NEW INFLATOR



- **DO NOT** connect the inflator harness at this time. It is **CRITICAL** to first confirm that the inflator is installed in the correct position before connecting the harness.

DO NOT CONNECT PREMATURELY  
CANNOT DISCONNECTED

**NG**

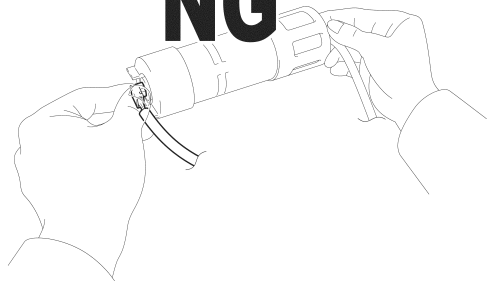

R170128003

**NOTE:** Once connected the inflator harness cannot be disconnected without damaging the connector, and would require that the inflator and harness be replaced.

- a) Carefully slide the new inflator half way into the airbag assembly and align as shown.

**DO NOT** insert fully.

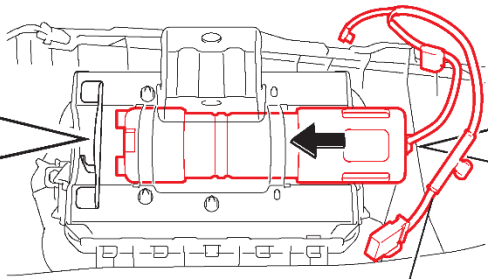
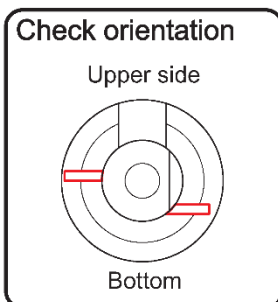

Instrument panel wire

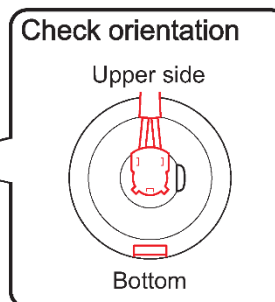

R1702010006H

- b) Connect the connector to the inflator and ensure that the connector lock is fully engaged as shown.

**ALIGN CONNECTORS**

Wire Harness Side:

Inflator Side:

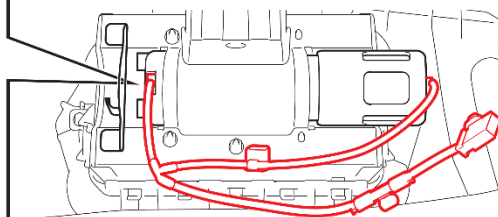
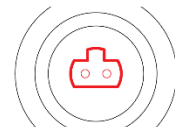
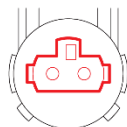

R1702010008H

a) Fully insert the inflator and ensure that the inflator is correctly oriented as shown.

**NOTE: DO NOT pinch the wiring between the bracket and the inflator.**

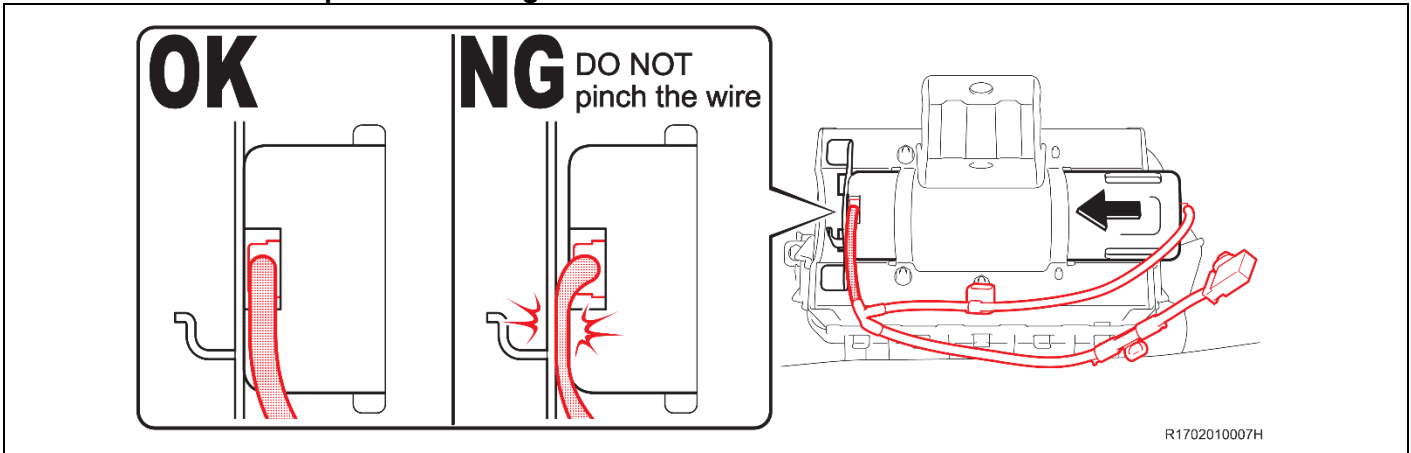

**NOTE: Ensure the inflator is correctly oriented.**

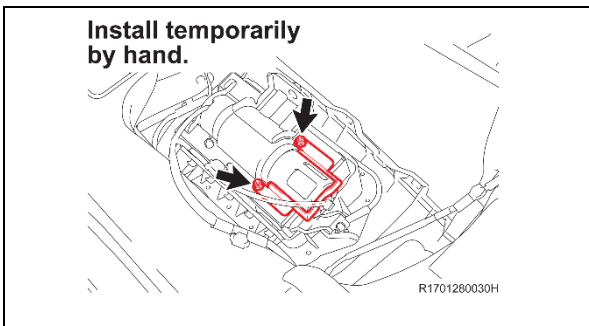
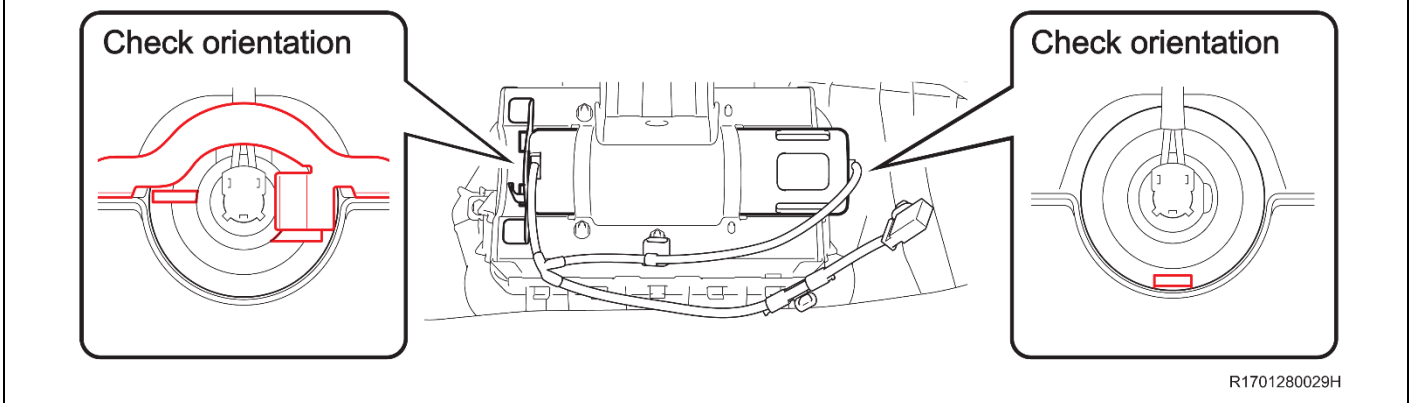

b) Install the **NEW** stopper plate.

c) Install 2 **NEW** nuts by hand.

**NOTE: Ensure that the stopper plate is the one from the kit and installed in the correct orientation.**

Install temporarily by hand.

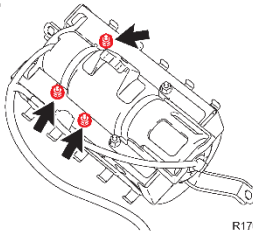

- d) Remove and discard the 3 remaining nuts and install the 3 **NEW** nuts
- e) Loosely tighten the nuts by hand. They will be torqued on a later step.

**NOTE: You may need to turn the airbag to the left or right to access the center nut.**

- f) Push the inflator towards the position determining plate and eliminate any gaps.



- If any gaps exist, the flats may move apart and could result in abnormal operation during airbag deployment.

## 7. TORQUE THE PLATE NUTS

- a) Tighten the 5 nuts evenly in several increments in the sequence shown. Use a socket driver or torque wrench to tighten the nuts.

Torque: 35in. lbf (40 kgf.cm, 3.9N·m)



- There will be some resistance when tightening the nuts because they are self-locking, confirm the nuts are tightened correctly.
- **DO NOT** use a power tool, T-handle, or ratchet when tightening the nuts to avoid overtorquing and deforming the studs.
- You may need to turn the airbag to the left or right with in the mounting bracket to access the center nut.

**OK**

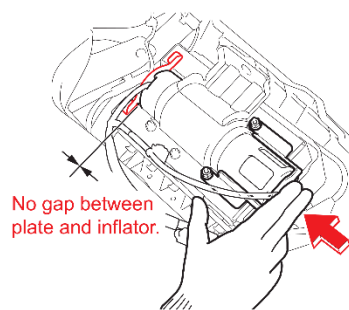

Socket Driver

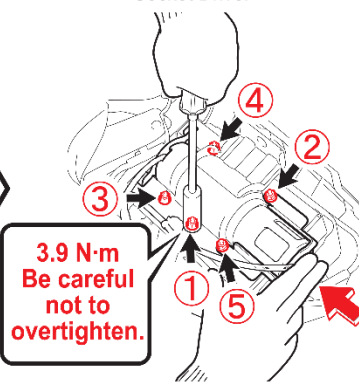

**NG**

**NG**

**NG**

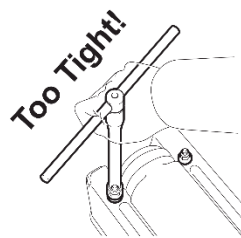
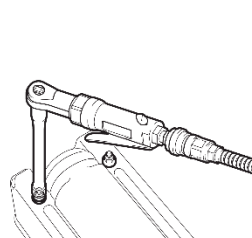

**These tools cause overtightening !**

R1702010002H

- b) Remove the airbag from the bracket.



## 8. INSPECT THE AIRBAG BEFORE INSTALLATION

- a) Confirm the **NEW** inflator and 5 **NEW** nuts have been installed.
- b) Confirm the position of the inflator and position determining plates are correct.
- c) Confirm the routing of the inflator wire harness.

(a) Replacement  
of parts.

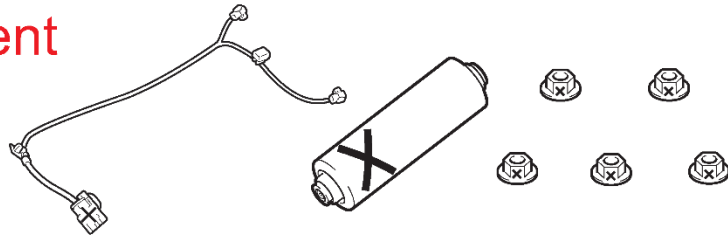

(b) No gap.

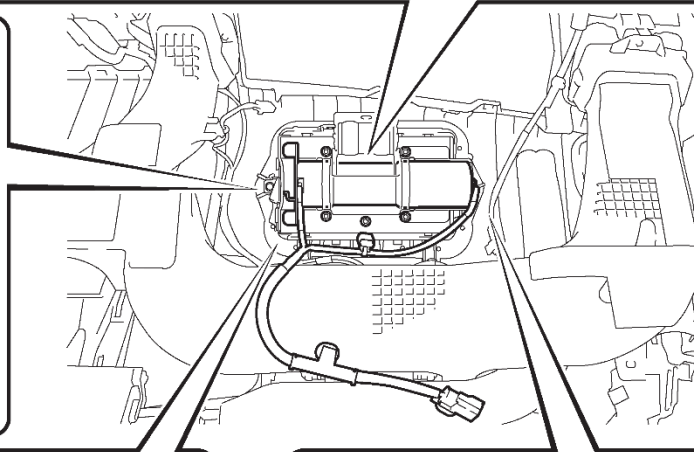
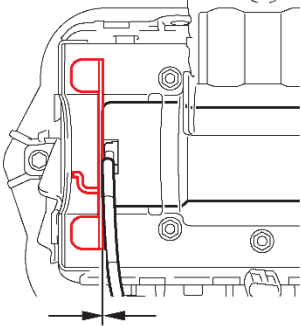

(b) Check  
orientation

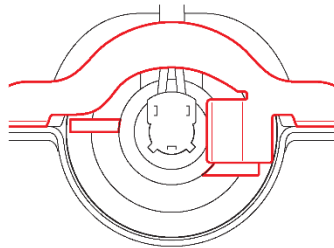

(b) Check  
orientation

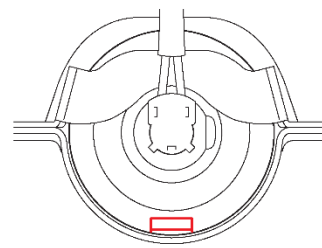

R1701280031H



## XI FRONT PASSENGER AIRBAG ASSEMBLY INSTALLATION

### 1. REINSTALL THE AIRBAG ASSEMBLY

a) Refer to TIS for instructions on airbag installation:

[2011 MY](#) [2012 MY](#) [2013 MY](#) [2014 MY](#)

### 2. RECONNECT THE NEGATIVE BATTERY CABLE

### 3. PREFORM ANY NEEDED VEHICLE INITIALIZATIONS

### 4. PERFORM A HEALTH CHECK AND DIAGNOSTIC REPORT

## ◀ VERIFY REPAIR QUALITY ▶

- Confirm all precautions are followed to ensure safety during the repair
- Confirm the entire serial number checker application is completed and the warranty authorization # is recorded on *EVERY* vehicle
- Confirm the old inflator is handled safely and given to the appropriate parts professional for shipment
- Confirm the inflator harness connector is fully engaged and that the stopper plate and position determining plate are installed correctly

If you have any questions regarding this update, please contact your regional representative.

## XII APPENDIX

### A. CAMPAIGN DESIGNATION DECODER

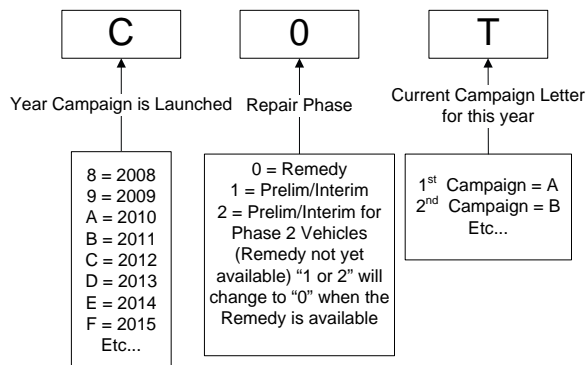

### B. CAMPAIGN PARTS DISPOSAL

**ALL** inflators that are removed from vehicles under this campaign **MUST** be packaged and shipped back to the inflator manufacturer following the manufacturer's instructions. The instructions can be found in the following locations:

- Attached to the dealer letter