

### 3. ATTACH PRESSURE HOLDING TOOL

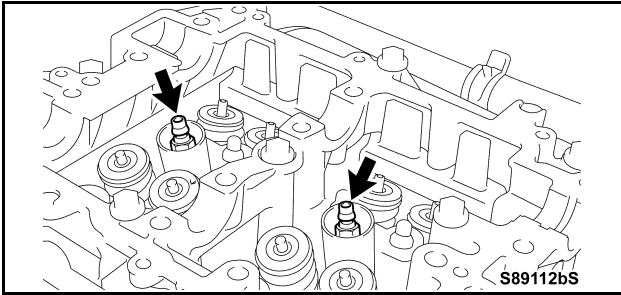

**DO NOT** use any tools for tightening, or the air adapters may be damaged.



a) Attach the 2 air adapters by hand.

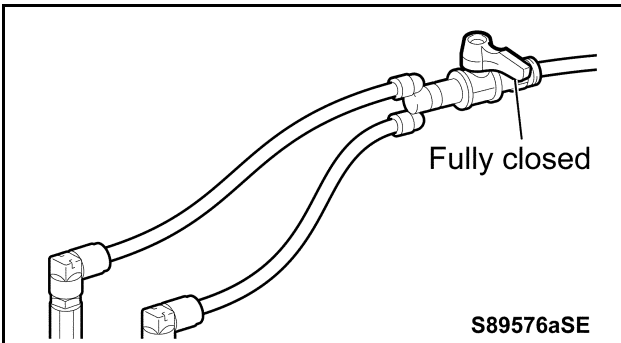

b) Confirm that the valve is fully closed.

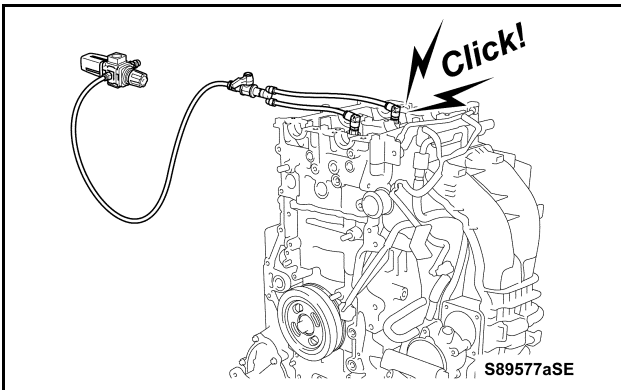

c) Connect the air hose to the 2 air adaptors.

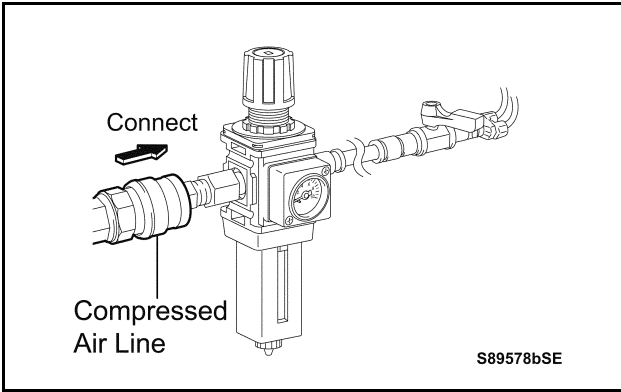

d) Connect the compressed air line.

**[IMPORTANT] 6 TIPS TO PREVENT WORK ERRORS**

**NG**

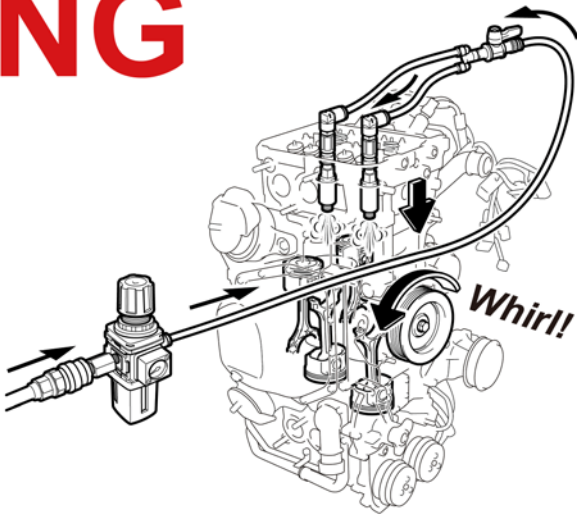

Slowly open using full 5 sec.

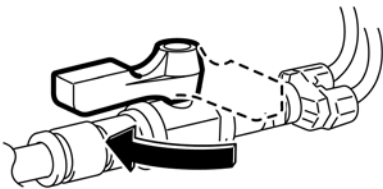

**4. APPLY PNEUMATIC PRESSURES  
(Cylinders No. 1 and No. 3)**



Be sure to **SLOWLY OPEN** the **VALVE**. **DO NOT** quickly open the regulator valve when applying pneumatic pressure to the cylinders at TDC and BDC, or the cylinder at TDC with small capacity will be filled with pneumatic pressure which apply pressure on the pistons, and cause the crankshafts to rotate.

- a) Slowly open the valve using a full 5 seconds.
- b) Check that no loud hissing noise (produced by air leaks) is heard.



If the crankshaft rotates, discharge the air and reset the crankshaft to the proper position.

**NG**

**Squeeze!**



**DO NOT** further tighten the air adapters using any tool if only a small hiss noise, caused by slight air leaks which would not interfere with later procedure, is heard.

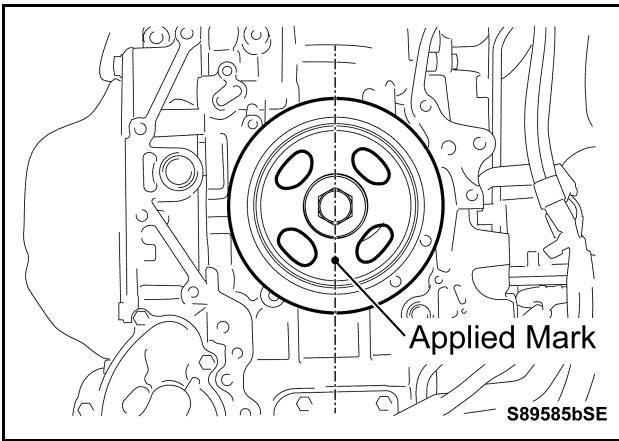

- c) Confirm that the mark applied on the crankshaft pulley is not in any position other than as shown in the illustration.



**If the position of the applied mark is not set as specified, reduce the pneumatic pressure and then adjust the crankshaft position again.**

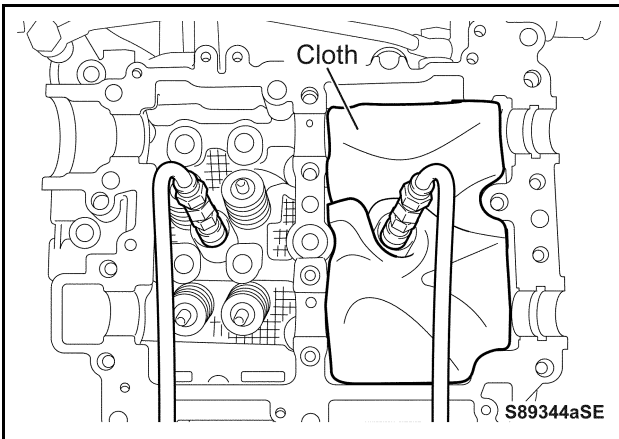

## 5. REPLACE VALVE SPRINGS

- a) Cover cylinder No. 1 with cloth as shown.

### NOTE:

**The purposes for using cloth is to prevent erroneously replacing cylinder No. 1 springs and also to prevent parts from falling.**

- b) Check the remover and replacer to confirm that the magnets and their periphery are free from problems such as adhesion of metal chips, parts fall, or damage.

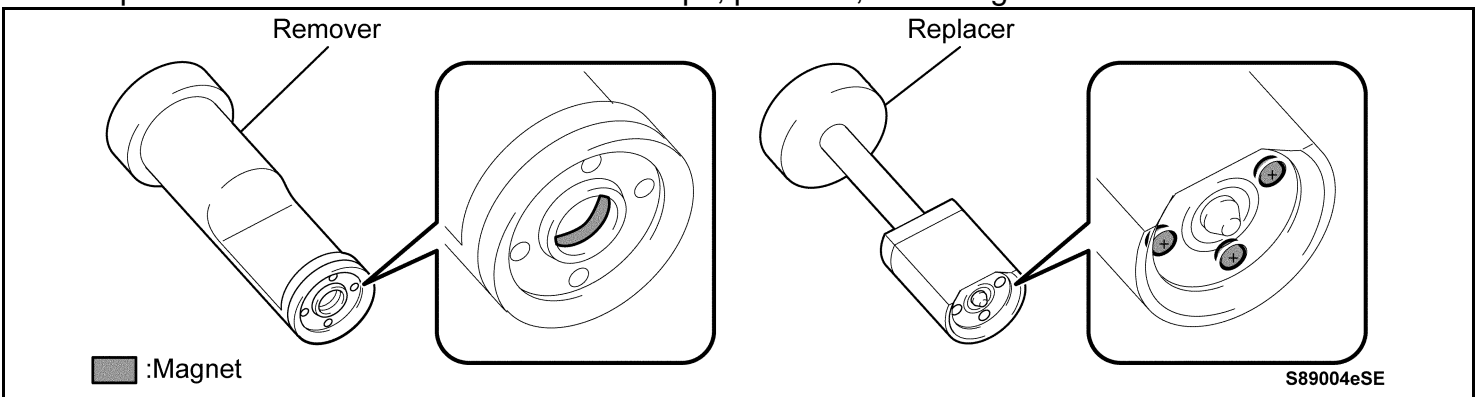

**Carefully read and fully understand the caution shown below before starting the following instructions.**

- c) Be sure to wear protective gloves and protective glasses during work.  
 d) Each valve spring must be pressed straight down approximately 6 mm (0.24 in.) using the remover. When the spring is compressed, the retainer and the retainer locks stick to the magnets of the tool.



Be careful, the cylinder head has sharp edges.

<Remover>

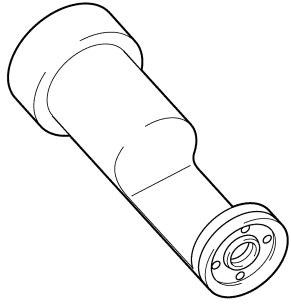

# Press straight

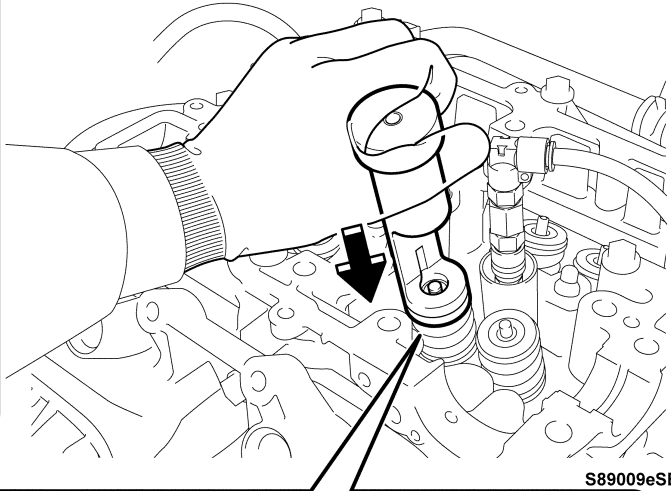

S89009eSE

<Cross Section>

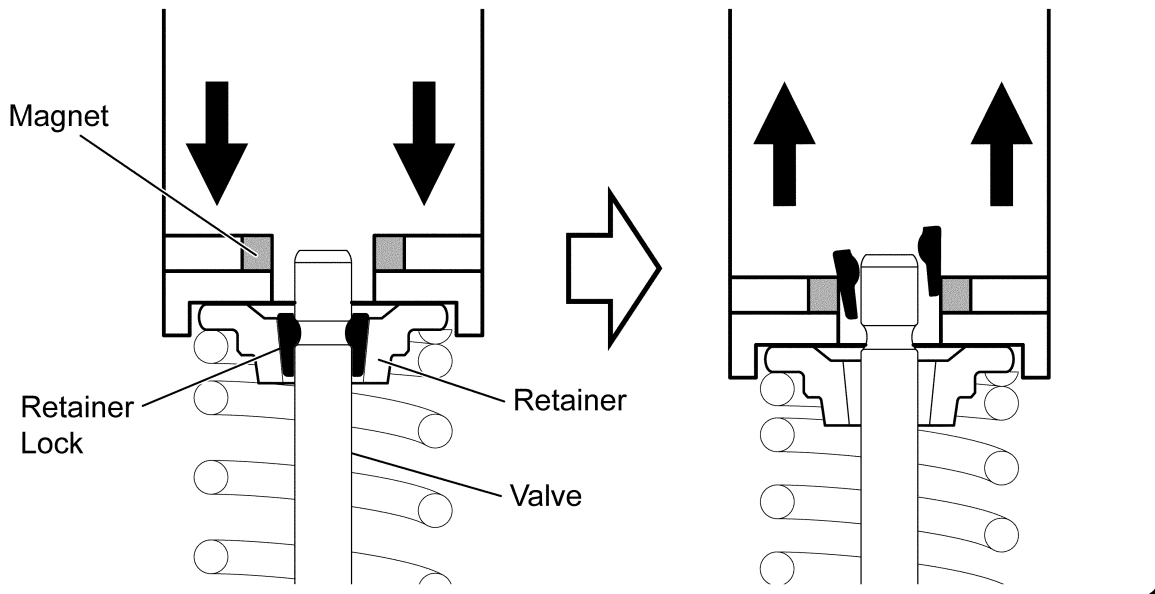

Wear protective glasses

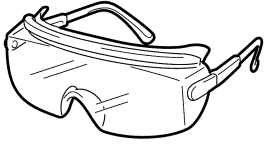

Wear protective gloves

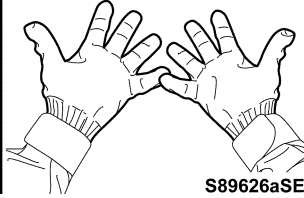

S89626aSE



- If the retainer locks are engaged improperly, the locks may disengage and the retainer may fly off.
- Be sure to wear protective gloves, as edges of the cylinder head may cause injuries in case the remover or the replacer is pressed improperly.

OK NG

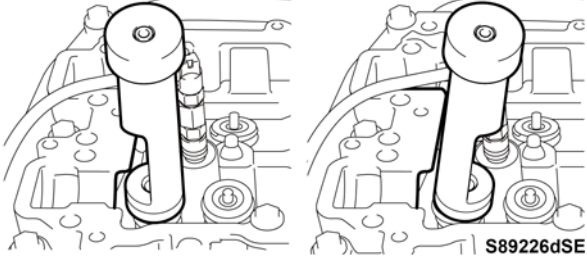

S89226dSE



If the tool is tilted and cannot be set straight, adjust the orientation of the tool's cutout portion and set it straight before proceeding any further.

NG

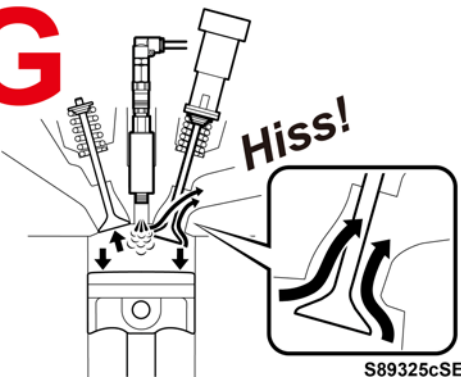

S89325cSE



- **DO NOT** forcibly press the valve, or air leaks from the combustion chamber may occur and the valve may drop into the chamber.
- Immediately stop the work if a loud hissing noise is heard, as air leaks have occurred.



Be sure to cover the remover by hand as shown, while removing the retainer and the retainer locks, just for in case.

OK



Cover with hand

NG

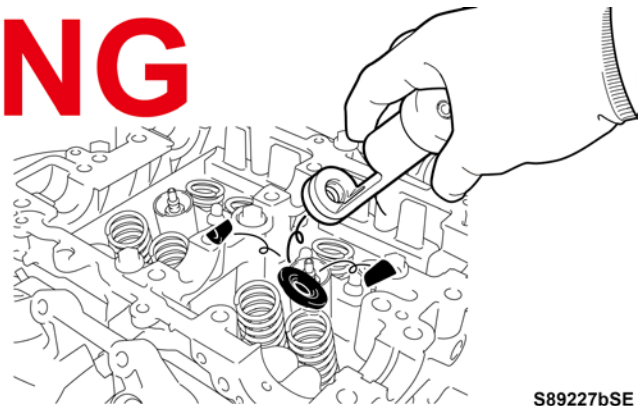

S89227bSE

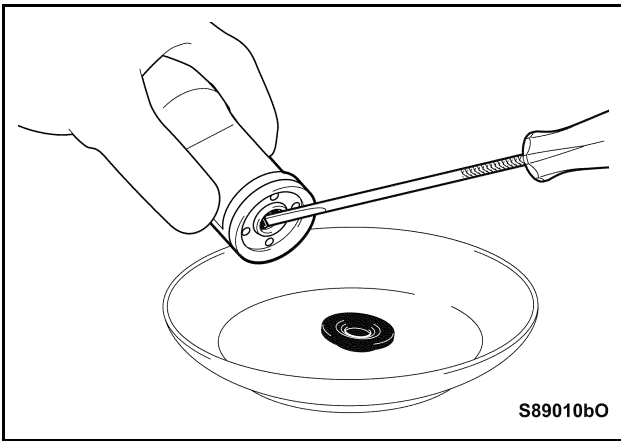

- e) Detach and remove the retainer and the retainer locks from the magnets.



**The retainer and the retainer locks will be reused.**



- f) Remove the valve spring, mark and then store it in a separate container so as not to reinstall it in error.



- Store the valve springs in order so as not to mix **NEW** and old ones.
- Replace all 16 valve springs with **NEW** ones, even when blue markings, the same as those on **NEW** ones, are applied.

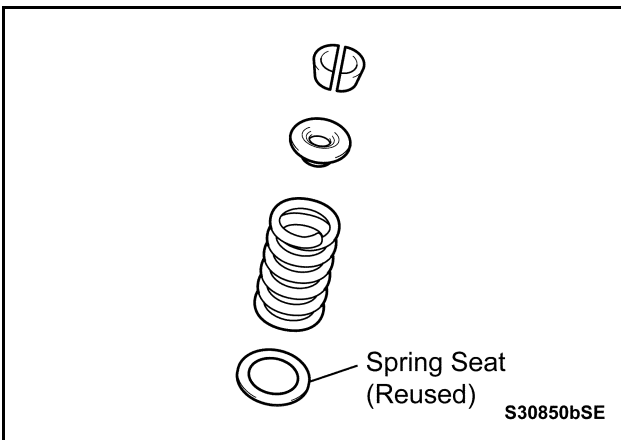

**NOTE:**

The spring seat under the spring will be reused. (Spring seats **DO NOT** have to be removed from the engine.)



**DO NOT** allow any spring seat to drop into the engine. Although most spring seats remain on the engine, certain spring seats come together with the springs when the springs are removed.

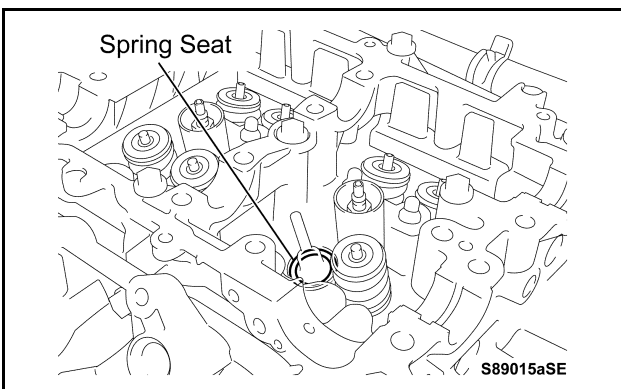

- g) Check that the spring seat (can be installed facing either direction) is set on the engine.

## Light blue mark at top

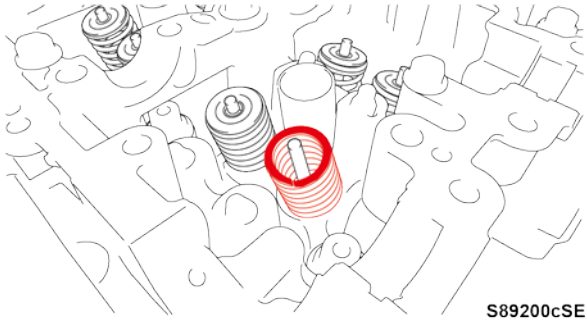

- h) Set a **NEW** valve spring on the cylinder head with its light blue mark side facing upward.

### NOTE:

Setting the **NEW** valve springs with the light blue marks on the upper side makes it easy to confirm which valve springs have been replaced.

(Setting the valve springs with the marks on the opposite side causes no functional problems.)

## Wear protective glasses

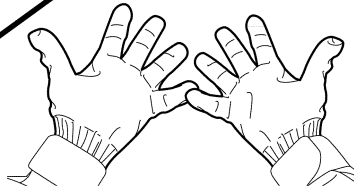
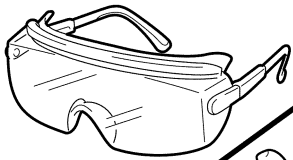

S00001aS

## Wear protective gloves

- i) Wear protective glasses.



**If the retainer locks are engaged improperly, the locks may disengage and the retainer may fly off.**

- j) Wear protective gloves.



**Be sure to wear protective gloves. Sharp edges on the cylinder head may cause injuries in case the remover or replacer is pressed improperly.**

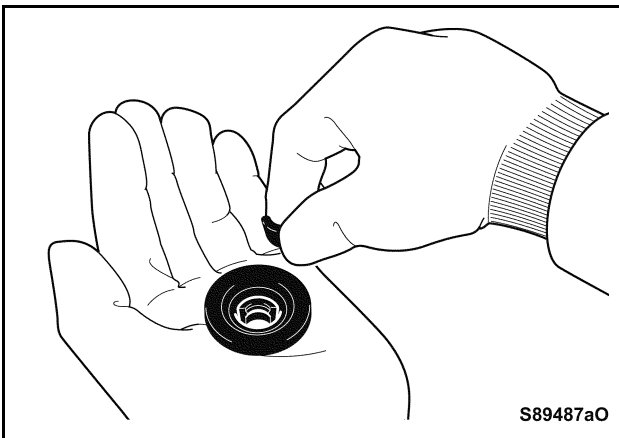

- k) Set the 2 retainer locks on the retainer.

- l) Set the retainer and the retainer locks on the replacer.
- m) Check the guide shaft tip to ensure that it is not stuck but is properly protruding as shown.



- If the guide shaft is not protruding properly as shown, lightly push it with a flathead screwdriver.
- Make sure the retainer locks are set properly without tilting toward the guide shaft.

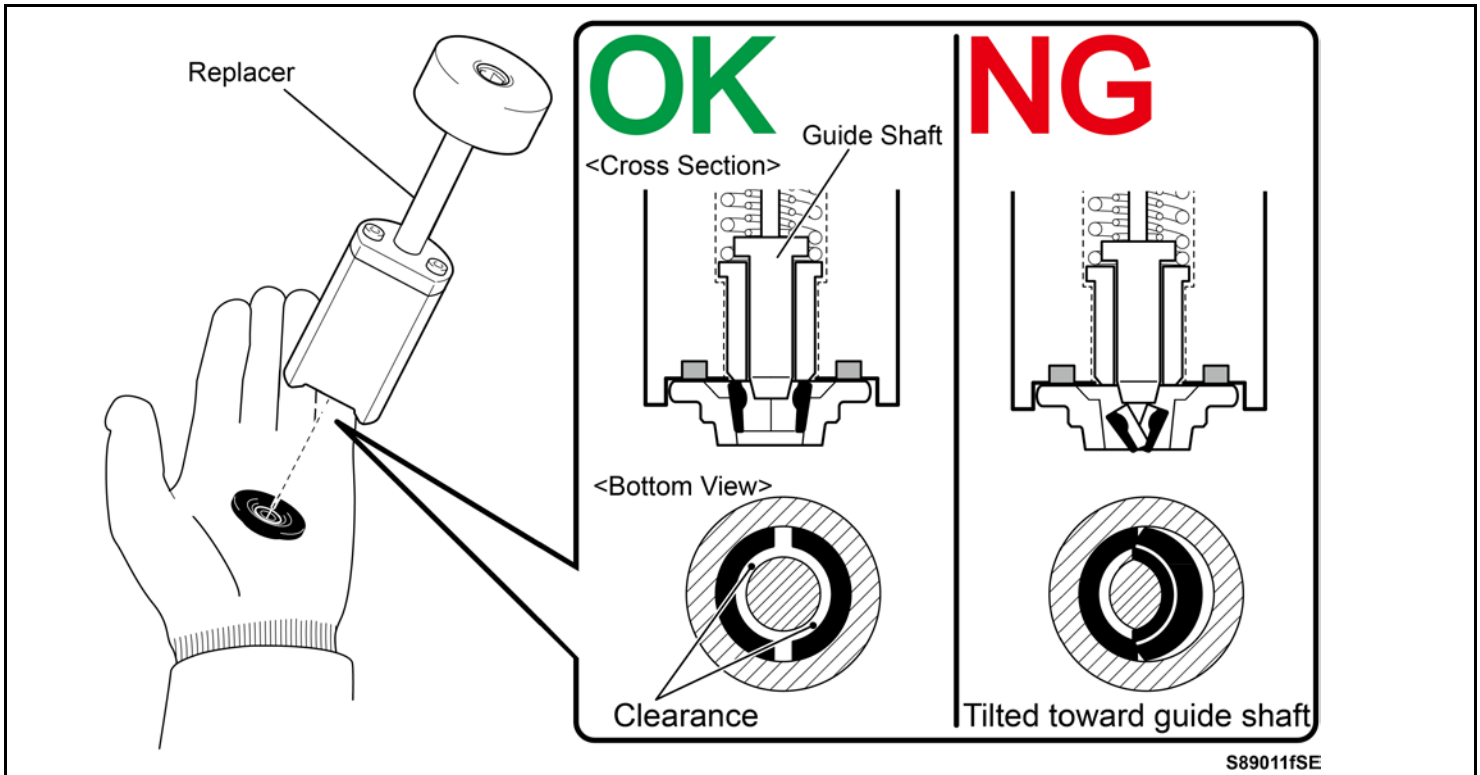

- n) While covering the replacer by hand, set the replacer on the valve. If the replacer is not covered by hand, a retainer or retainer lock attracted to the magnets may accidentally fall into the engine.

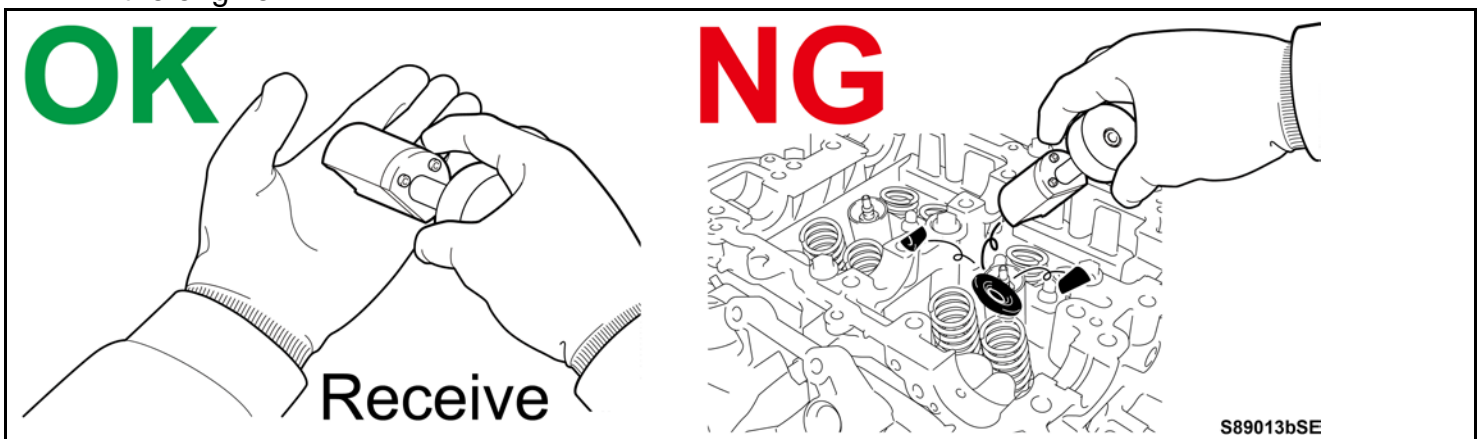



- o) Set the replacer guide shaft end on the valve stem end as shown, and push the replacer straight downward until the spring is compressed by approximately 12 mm (0.47 in.), to install the retainer and the retainer locks. Be careful when removing the tool, as the retainer locks may not be installed properly.



**Although cautions for the remover also applies to the replacer, more care is needed for the replacer. Be sure to push the replacer straight with its guide shaft end set properly on the valve stem end as shown, to securely assemble the retainer locks.**

## Press straight

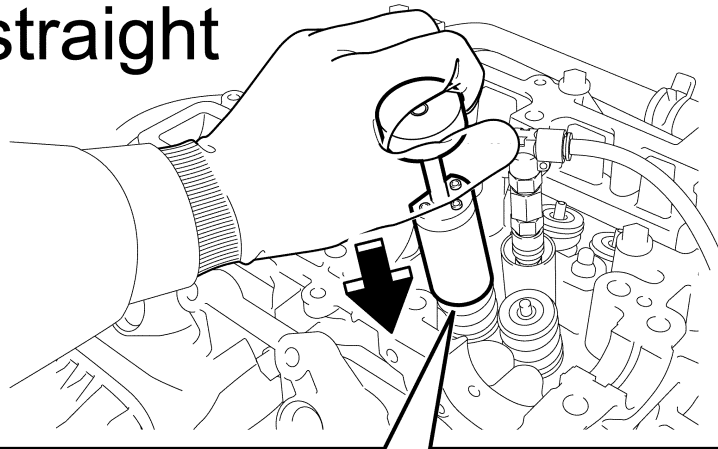

S89012hSE

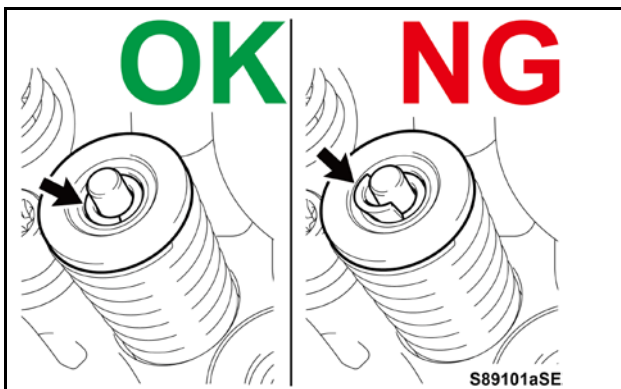
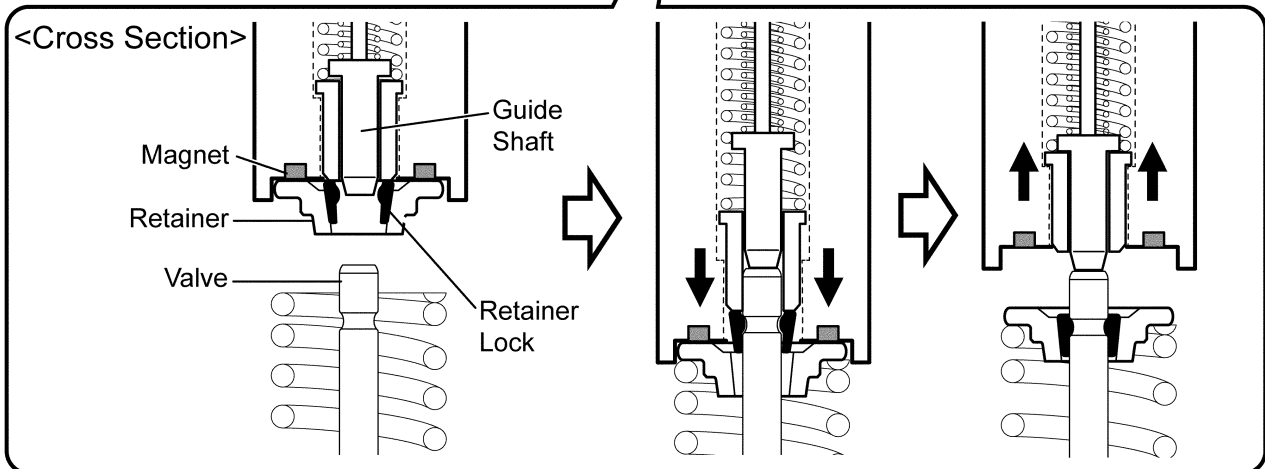

S89101aSE

- p) Visually confirm that the retainer locks are securely engaged with the valve.



**DO NOT strike the retainer or the retainer locks with a brass bar etc. to confirm engagement.**

- q) If the retainer lock is tilted and locked, using a remover, remove and reinstall the retainer locks.

## [IMPORTANT] 6 TIPS TO PREVENT WORK ERRORS

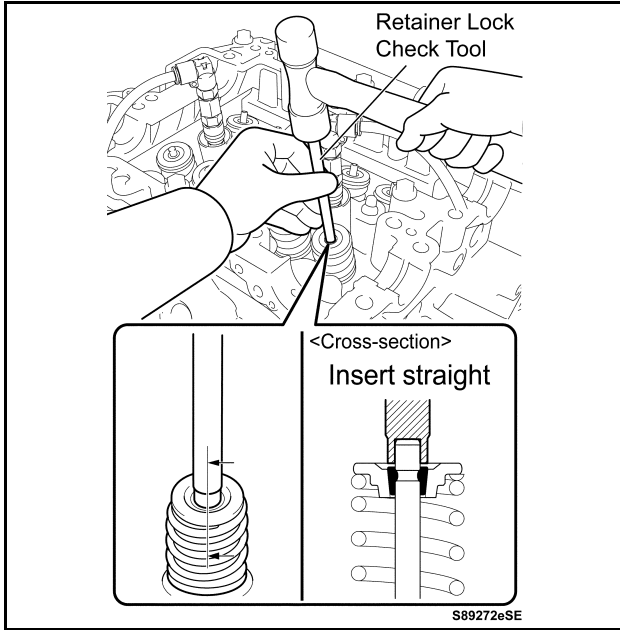

- a) Insert the retainer lock check tool to the valve stem tip, and then lightly tap it to properly seat the retainer locks.



**DO NOT** strike the tool or improperly insert the tool to the tip of the valve stem, or problems such as disengagement of the retainer lock and damage to the valve stem tip may result.

### NOTE:

The valves open when the tool is lightly tapped, causing a pop sound and a slight air leak.

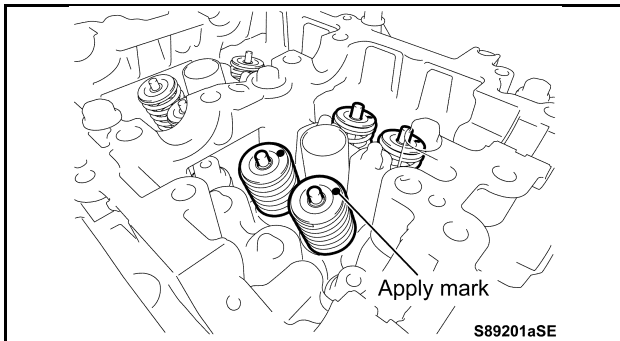

- b) Apply a mark on the retainer after completion of each replacement, to avoid erroneously replacing the same valve springs.
- c) Repeat the same valve spring replacement procedure until the 2 valve springs on the intake side and the 2 valve springs on the exhaust side have been replaced.

- d) Reset the air hose to the default condition.

**No matter what the conditions of the tool are (installed to the engine or not, the valve is open or closed, etc.), problems such as the crankshaft being rotated by pneumatic pressure can be avoided by following the procedure below.**

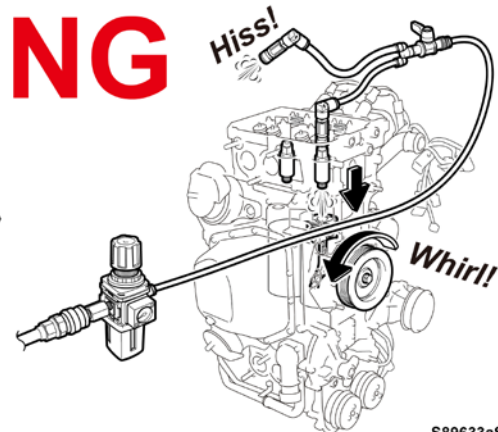
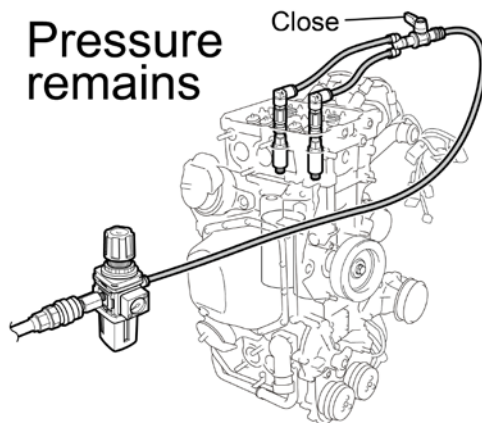

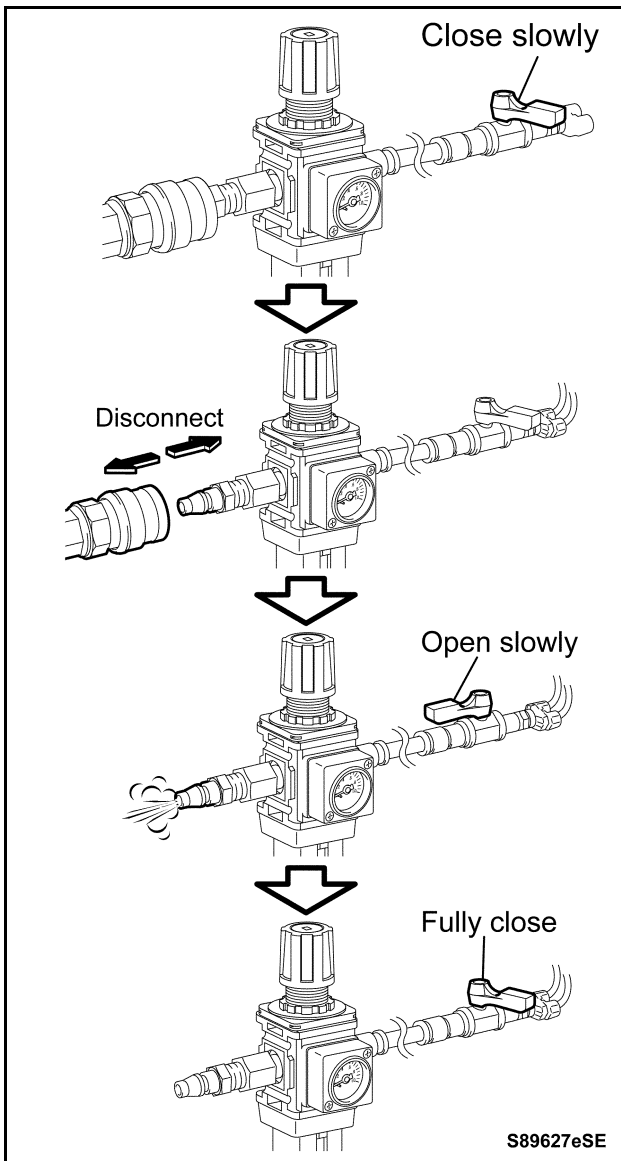

- 1) Slowly close the valve to stop the air flow.
- 2) Disconnect the compressed air line from the regulator.
- 3) Slowly open the valve to bleed off the remaining pressure.
- 4) Close the valve.

# CYLINDER NO. 1 VALVE SPRING REPLACEMENT

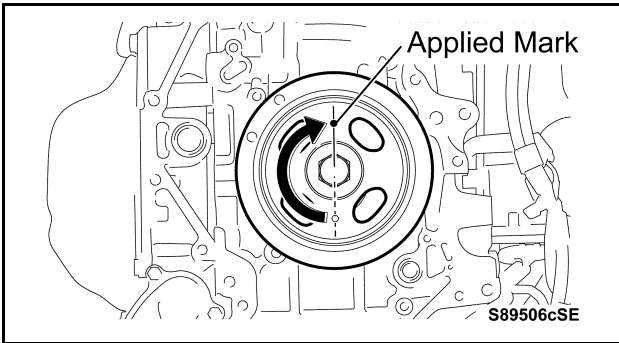

## 6. SET CYLINDER NO. 1 AT TDC

- a) Rotate the crankshaft pulley 180 degrees clockwise until the mark on the pulley is at the top as shown in the illustration (at the left side, when the engine is installed to the vehicle).

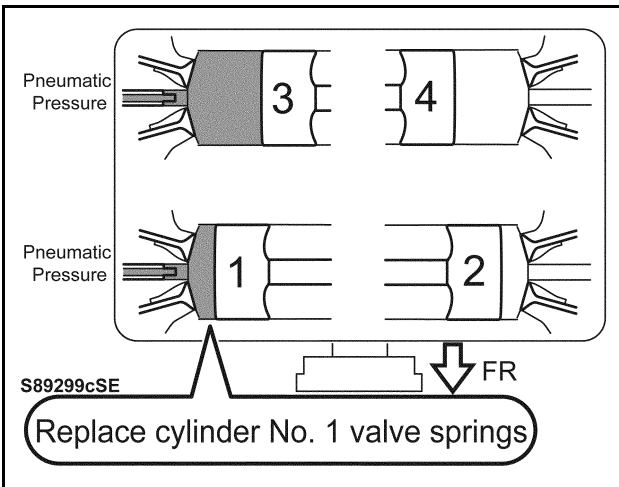

## 7. REPLACE NO. 1 CYLINDER VALVE SPRINGS

- a) Replace the No. 1 cylinder valve springs using the same removal procedure as for the No. 3 cylinder valve springs.



**Before proceeding with the replacement procedure, be sure to carefully read over the instructions for replacement of No. 3 cylinder valve springs, to fully understand the necessary work procedure and the cautions.**

- b) Slowly apply pneumatic pressure.

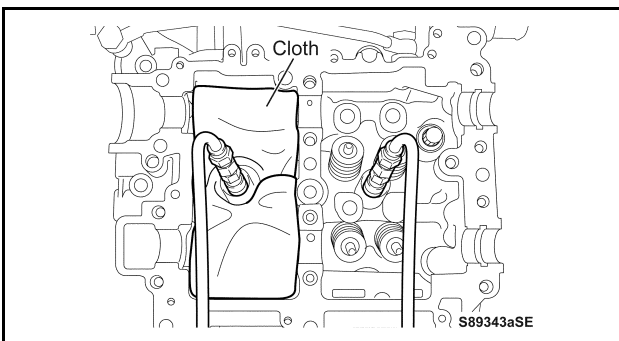
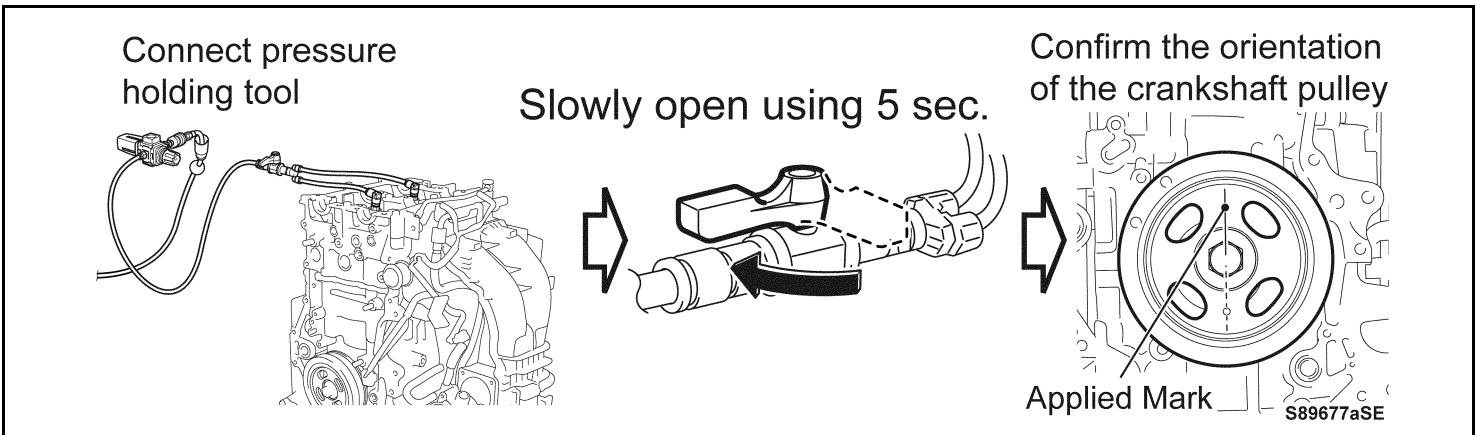

- c) Remove the cloth from cylinder No. 1, and then place it to cover cylinder No. 3 as shown.

- d) Confirm that the remover and the replacer are free of damage and contamination, and then wear protective glasses and protective gloves.
- e) Replace the cylinder No. 1 valve springs.
- f) Reset the pressure holding tool to the default condition (zero pressure).

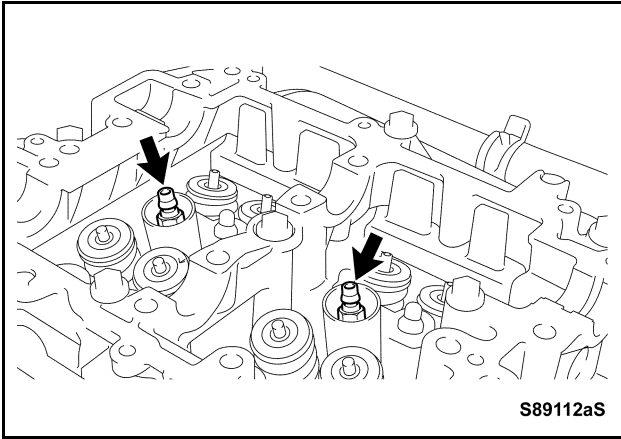

- g) Detach the 2 air adapters.

### XIII. REINSTALLATION OF CAMSHAFTS (RH BANK)

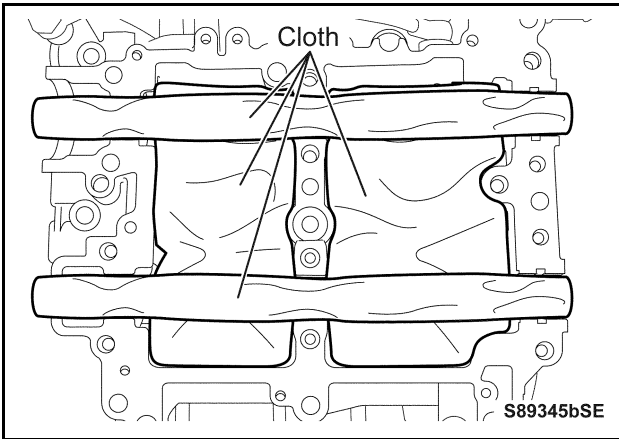

#### 1. CLEAN AND DEGREASE COMPONENT INSTALLATION SURFACES

- a) Place pieces of cloth as shown to prevent any seal packing to enter inside the cylinder head.
- b) Place pieces of cloth to prevent dirt from entering the oil holes in the journal mating parts.
- c) Remove the old seal packing.
- d) Degrease the seal packing adhesion surfaces.
- e) Remove the cloth.

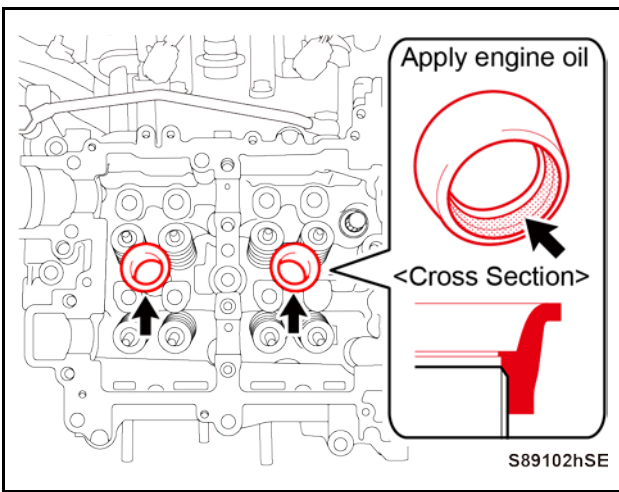

#### 2. INSTALL **NEW** SPARK PLUG TUBE GASKETS

- a) Apply thin coat of engine oil to the 2 **NEW** spark plug tube gaskets in the specified portions.
- b) Place the 2 spark plug tube gaskets in the correct orientation as shown and press them in as far as they can go with hand to install.

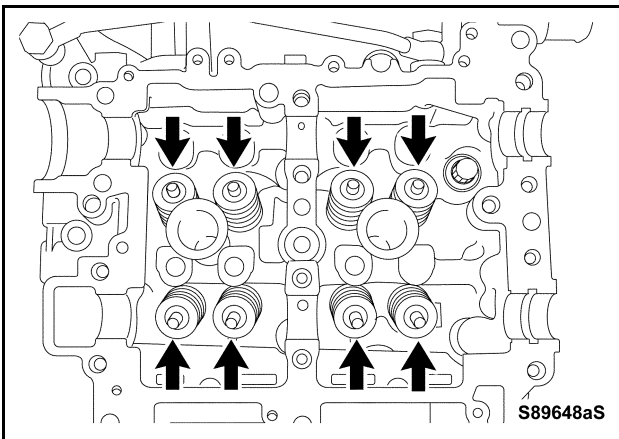

#### 3. CONDUCT INTERMEDIATE INSPECTION 1

- a) Check cylinders No. 1 and No. 3 to confirm that all 8 valve springs have been replaced. (**NEW** valve springs are applied with light blue marks.)
- b) Confirm that the valve spring retainer locks are properly installed.

## [IMPORTANT] 6 TIPS TO PREVENT WORK ERRORS

The valve clearances are controlled by the valve rocker arms and the valve adjusting shims.

The removed components must be restored to their original locations.

If not, the valve clearances may be disturbed and result in engine malfunctions.

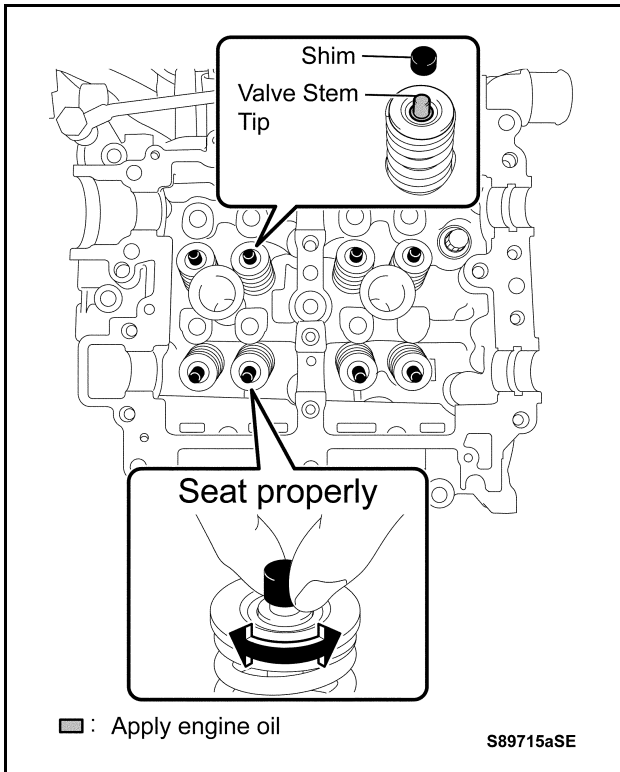

### 4. REINSTALL VALVE ADJUSTING SHIMS

- Apply engine oil to the tip of the valve stems.
- Reinstall the 8 adjusting shims to their original locations.
- Rotate the 8 adjusting shims to seat them properly.



Be sure to rotate the adjusting shims to seat them properly, or they may lift and fall.

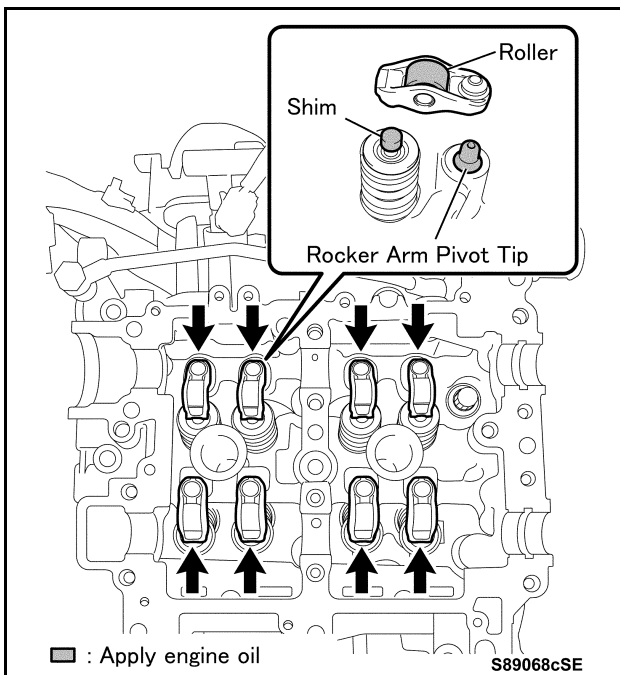

### 5. REINSTALL NO. 1 VALVE ROCKER ARM SUB-ASSEMBLIES

- Apply engine oil to the tips of the rocker arm pivots and the upper surfaces of the adjusting shims.
- Reinstall the 8 rocker arms to their original locations.

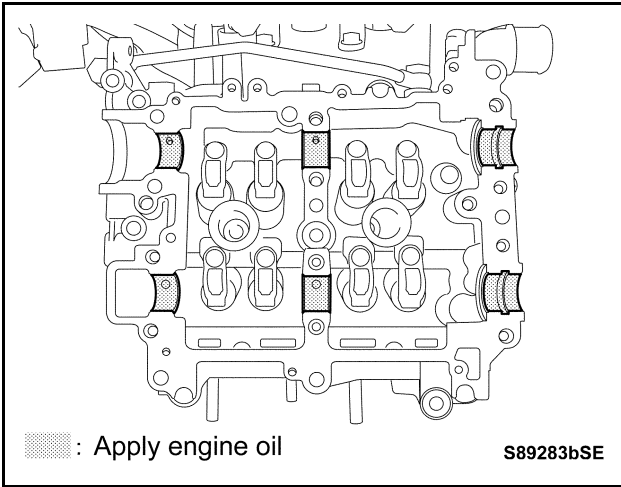

**6. REINSTALL CAMSHAFT (for RH Bank)**

- a) Apply engine oil to the camshaft housing bearings.



Confirm that the bearings are free of adhesion of foreign materials or dirt.

- b) Set the 2 camshafts on the camshaft housing.

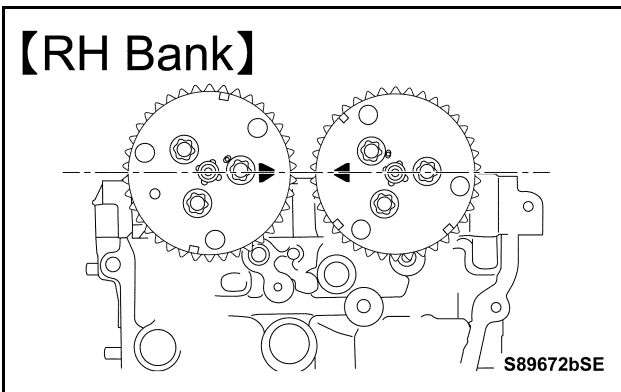
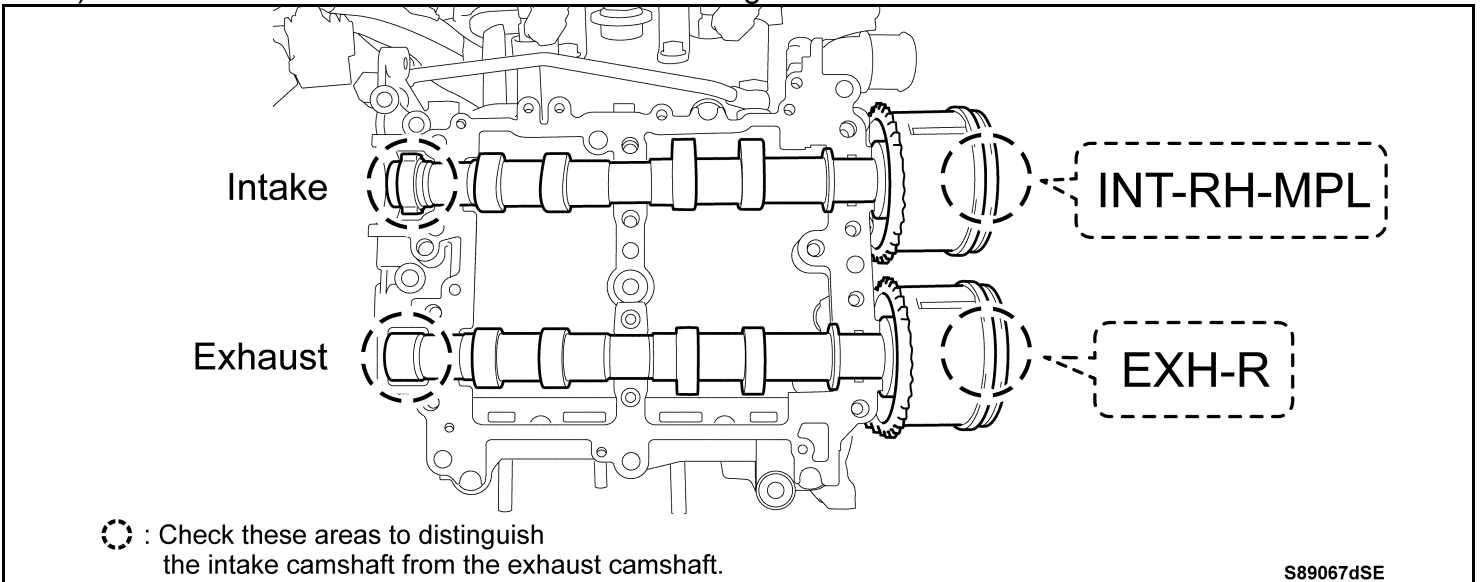

- c) Align the alignment marks to set both camshafts to no lift positions.



## 7. REINSTALL CAMSHAFT CAPS (for RH Bank)



- Seal packing needs to be applied to the front and rear camshaft caps for bonding.
- Each component must be attached within 5 minutes of seal packing application, and all bolts must be tightened to the specified torque within 15 minutes of the application.
- The bolts of the 5 camshaft caps (front, rear and center camshaft caps) must be handled as a set, and tightened uniformly and gradually in the specified order in several passes. Work efficiently and carry out the work as instructed below to have all the bolts tightened within 15 minutes.

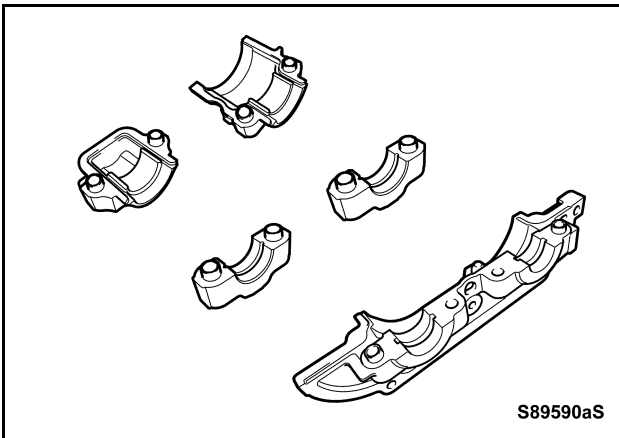

a) Clean and degrease the 5 camshaft caps.



**Make sure the grooves are clear of FIPG.**

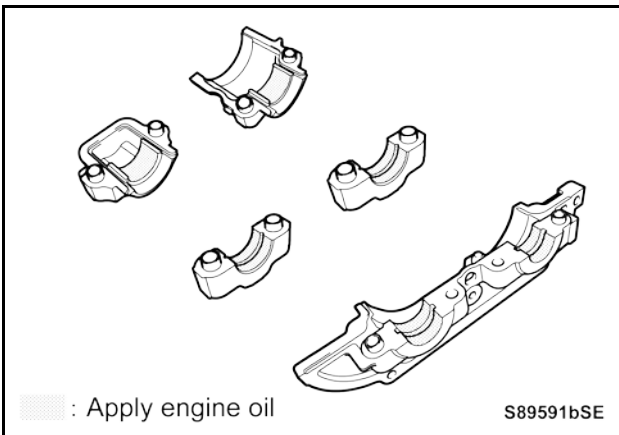

b) Apply thin coat of engine oil to 5 camshaft caps on the mating surfaces of the journals.



***DO NOT* excessively apply engine oil and allow it to condense, or the engine oil may adhere to the seal packing adhesion surfaces and result in insufficient sealing.**

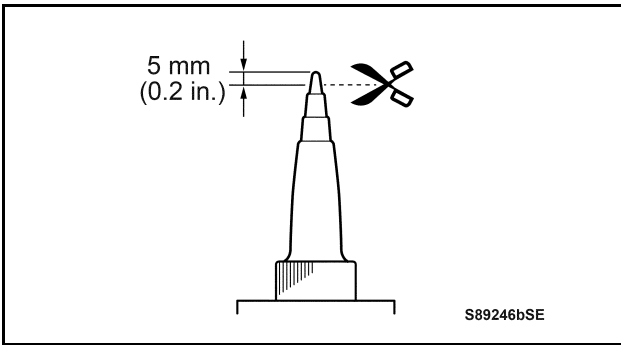

c) Cut off approximately 5 mm (0.2 in.) from the tip of a sealer gun nozzle.

**[IMPORTANT] 6 TIPS TO PREVENT WORK ERRORS**

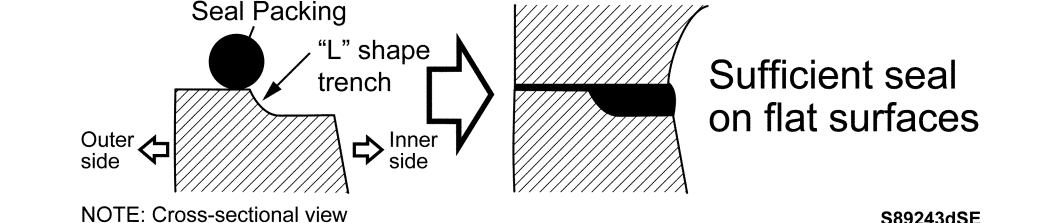
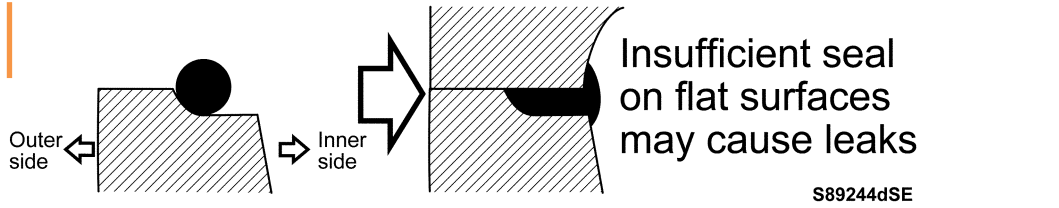

**DO NOT** erroneously apply seal packing to the L-shaped grooves.

Judgment	Locations to apply seal packing (Note: Conceptual cross-section drawings for seal packing application area are shown below.)	
<p><b>OK</b></p>	<p>Apply to the inner edge of the level surface</p>	
<p><b>NG</b></p>	<p>Apply to the "L" shape groove</p>	

**NOTE:**

Control the seal packing widths by adjusting the speed of sealer gun movement and operation of the sealer gun lever.

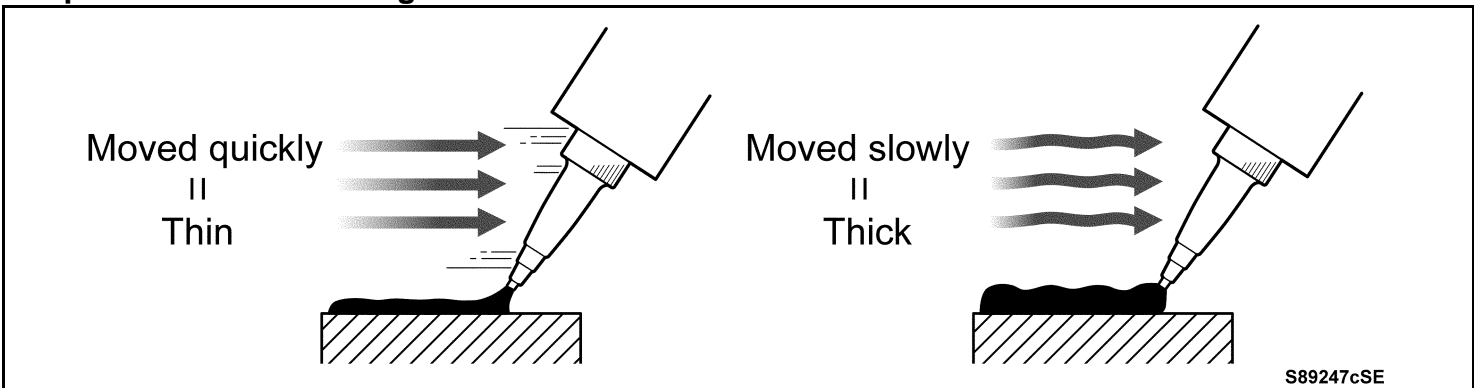

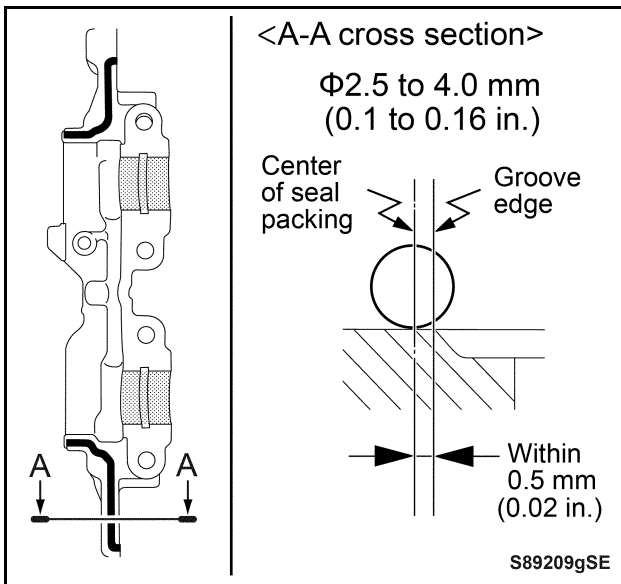

- d) Using the sealer gun, apply seal packing to the front camshaft cap.



- **DO NOT** allow seal packing to adhere to any part except the specified parts such as bearings, or the engine seizure may occur.
- Each component must be attached within 5 minutes of seal packing application, and all bolts must be tightened within 15 minutes of the application.

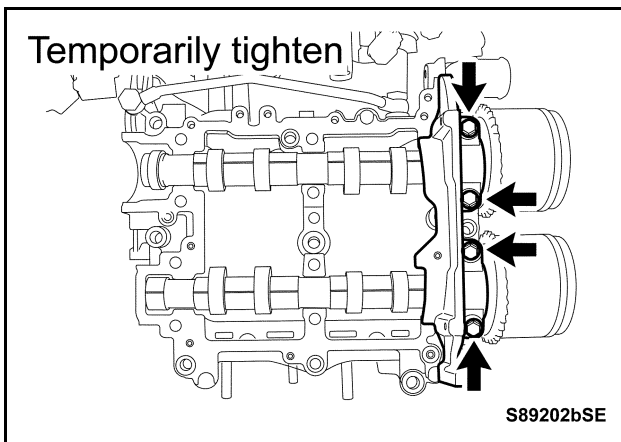

- e) Before temporarily reinstalling the front camshaft cap, make a final confirmation that the seal packing is applied in all necessary portions.
- f) Set the front camshaft cap, and temporarily reinstall it with the 4 bolts.

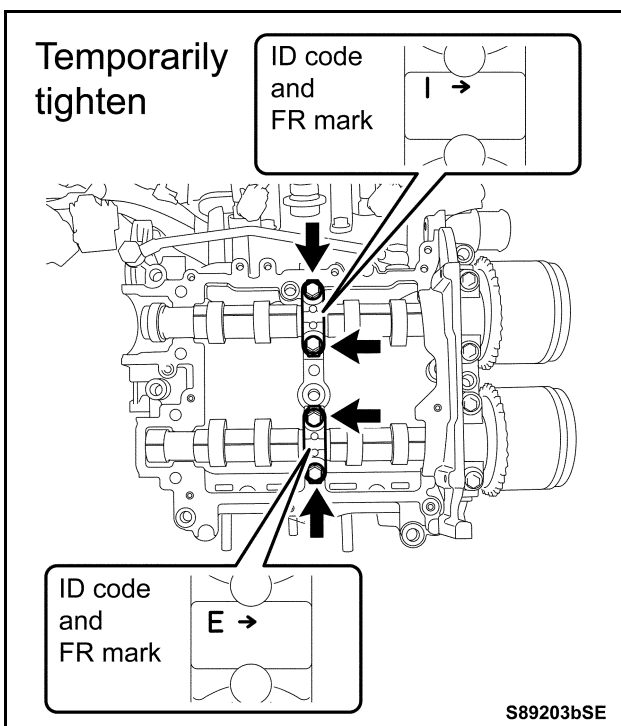

- g) Check the identification code and front mark on each center camshaft cap, set the 2 caps, and temporarily reinstall them with the 4 bolts.

- h) Remove the seal packing, which has got hard, from the tip of the sealer gun.
- i) Apply seal packing to the 2 rear camshaft caps.



- **DO NOT** apply excessive seal packing to the thin ( $\phi$  1.5 to 2.5 mm (0.1 to 0.16 in.)) seal packing application areas close to the bearings, or the engine seizure may occur.
- Each component must be attached within 5 minutes of seal packing application, and all bolts must be tightened to the specified torque within 15 minutes of the application.

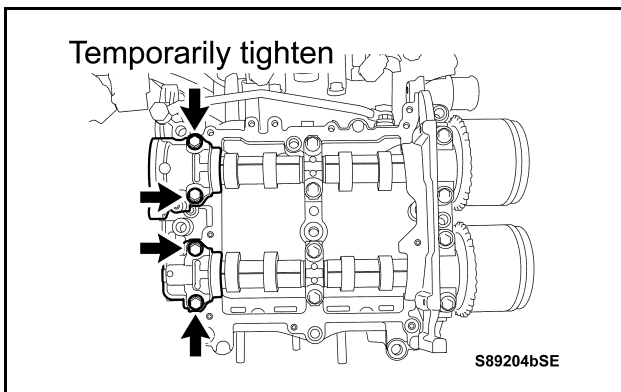
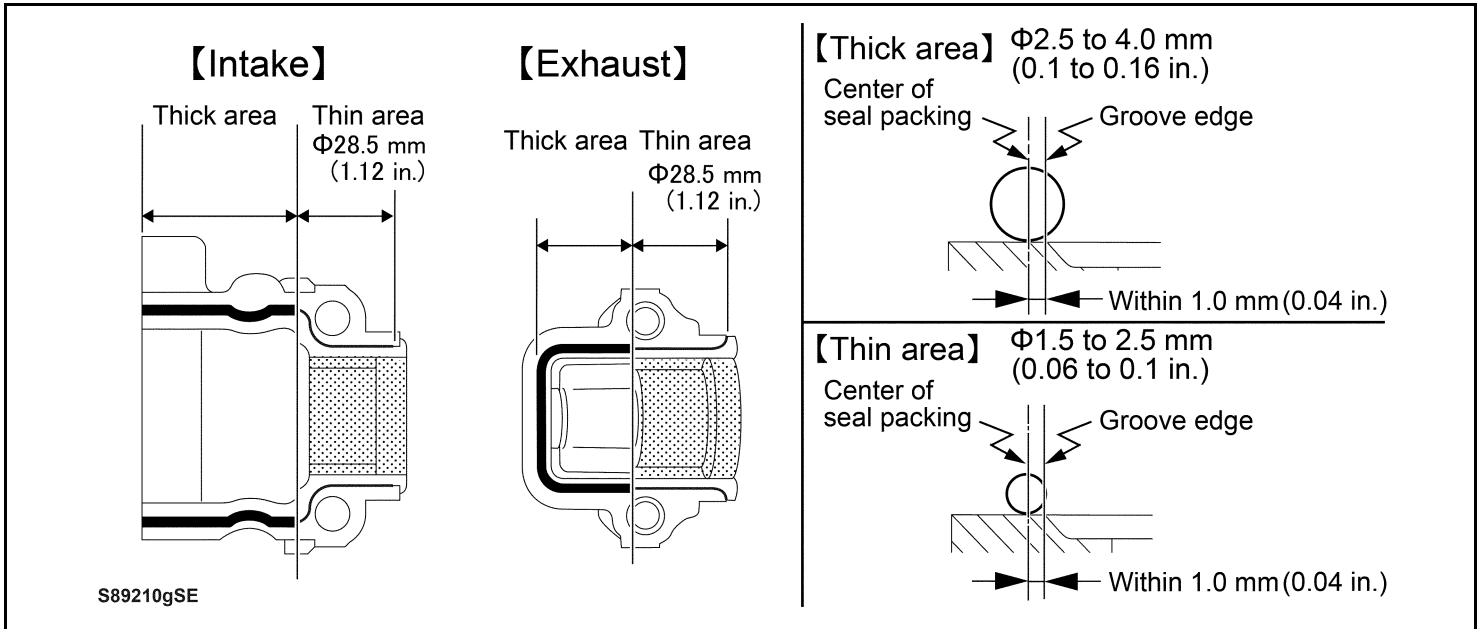

- j) Set the 2 rear camshaft caps and then temporarily tighten the 4 bolts.

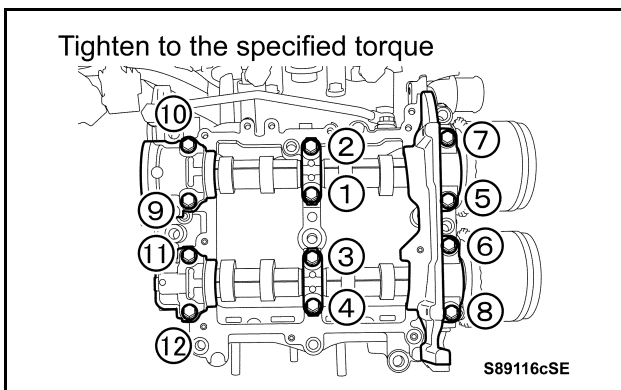

- k) Uniformly and gradually tighten the 12 bolts in the specified order in several passes.



**Make a minimum of 2 passes tightening the bolts before achieving torque.**

**Specified torque:**

**13 ft.\*lbf (18 N\*m, 184 kgf\*cm)**

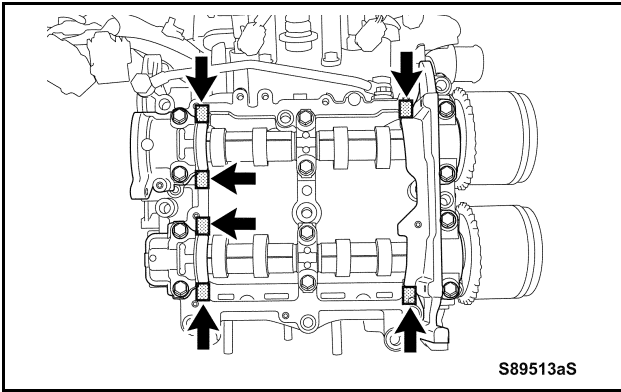

- l) Completely remove any excess seal packing outside the camshaft caps.

**STOP**

**If any excess seal packing remains outside the camshaft caps, insufficient sealing of the cylinder head cover may result when installing.**

**8. REINSTALL VACUUM PUMP ASSEMBLY (for Automatic Transmission)**

- a) Clean and degrease the vacuum pump assembly.
- b) Clean and degrease the vacuum pump assembly installation surfaces on the engine.
- c) Apply thin coat of engine oil to a **NEW** O-ring, and install the **NEW** O-ring.

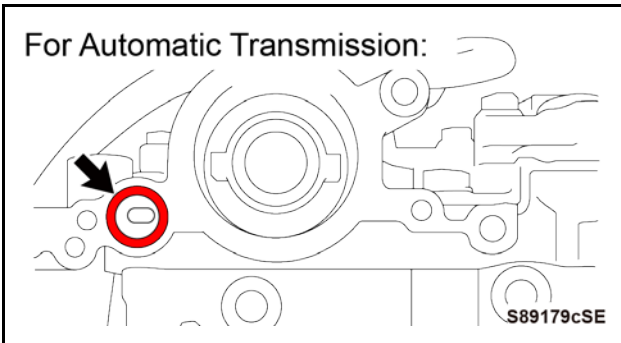

- d) Remove the seal packing, which has got hard, from the tip of the sealer gun.
- e) Apply seal packing to the engine in the locations specified in the illustration.

**STOP**

**Each component must be attached within 5 minutes of seal packing application, and all bolts must be tightened to the specified torque within 15 minutes of the application.**

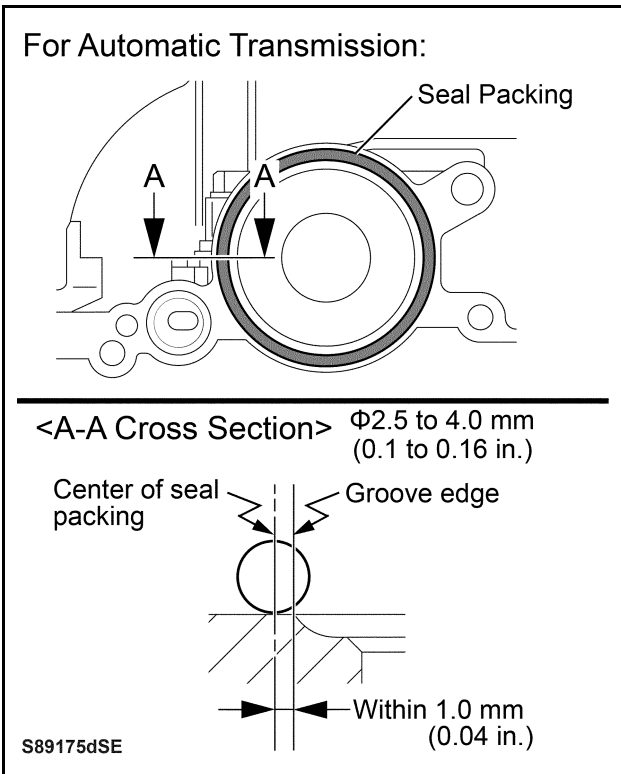

- f) Install the vacuum pump assembly with its concave portions matched with the convex portions of the camshaft.



**DO NOT allow O-rings to get caught between components.**

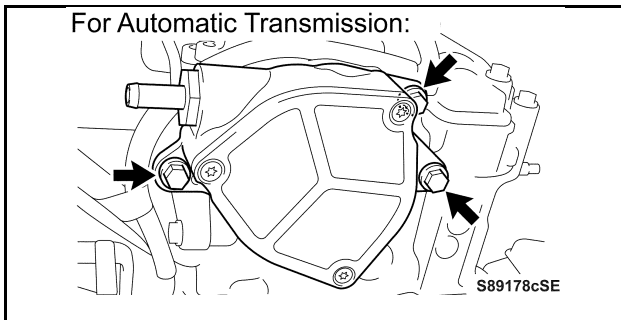
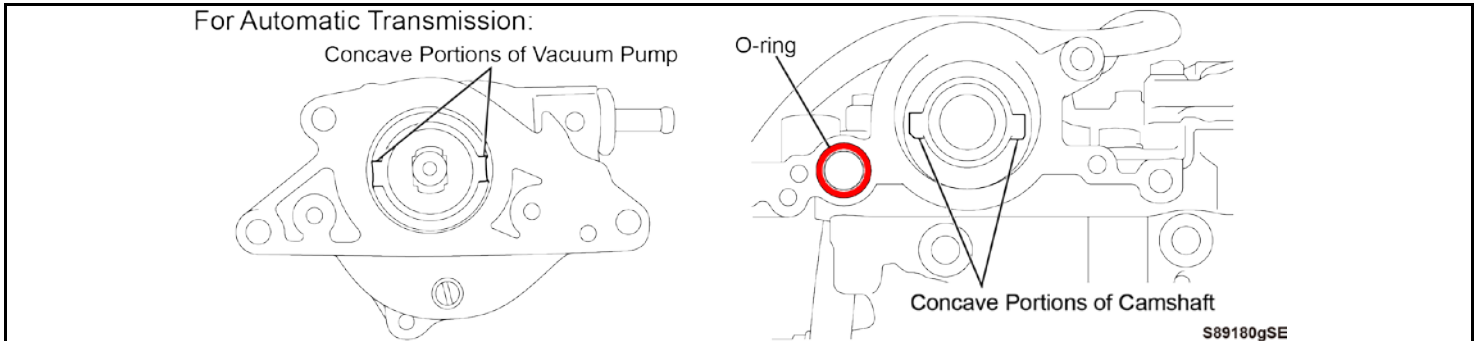

- g) Reinstall the vacuum pump with the 3 bolts.  
**Specified torque:**  
**12 ft.\*lbf (16 N\*m, 163 kgf\*cm)**

## 9. REINSTALL REAR CYLINDER HEAD PLATE (for Manual Transmission)

- Clean and degrease the rear cylinder head plate.
- Clean and degrease the rear cylinder head plate installation surfaces on the engine.
- Remove the seal packing, which has got hard, from the tip of the sealer gun.
- Apply seal packing to the engine in the locations specified in the illustration.

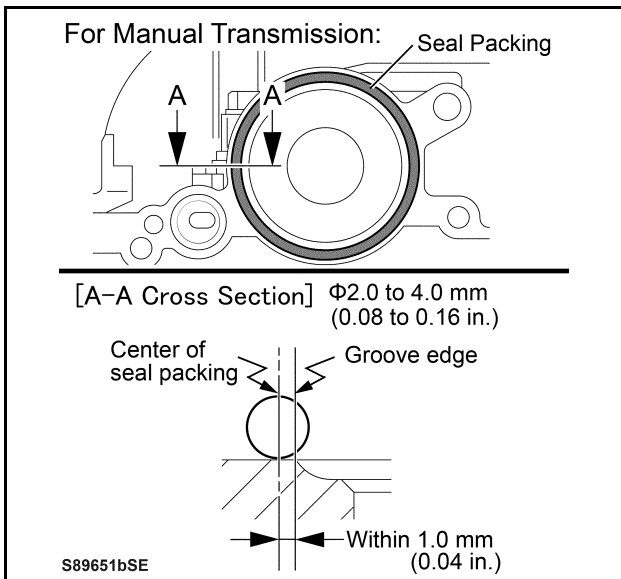

**Each component must be attached within 5 minutes of seal packing application, and all bolts must be tightened to the specified torque within 15 minutes of the application.**

- e) Install the 2 guide bolts.
- f) Attach the plate and temporarily install the bolt.
- g) Remove the 2 guide bolts, and then tighten the 3 bolts to the specified bolts to install the rear cylinder head plate.

**Specified torque:**

**12 ft.\*lbf (16 N\*m, 163 kgf\*cm)**

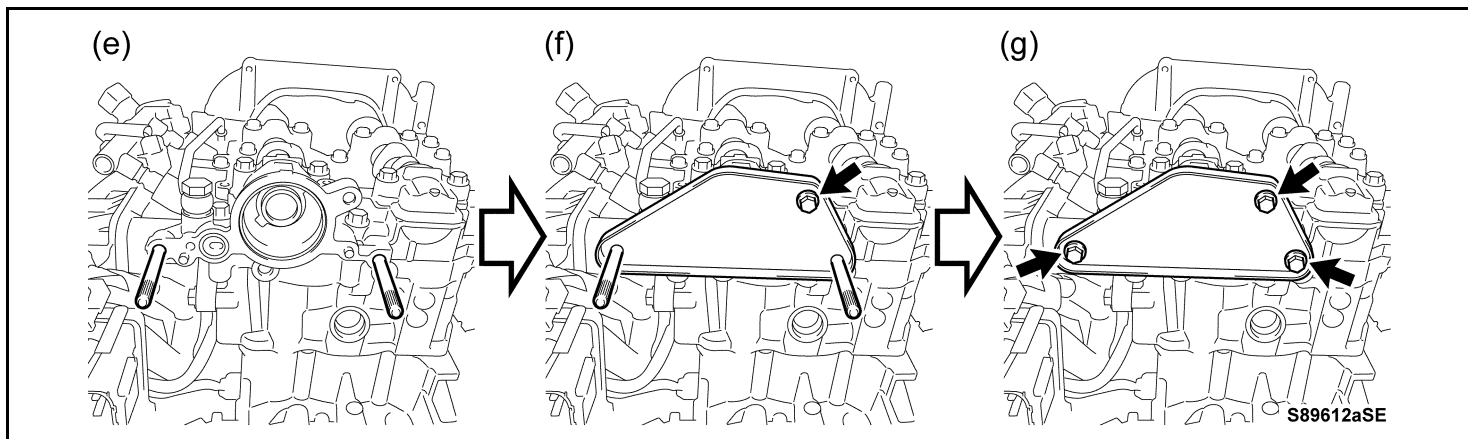

## XIV. INSTALLATION OF CYLINDER HEAD COVER (RH BANK)

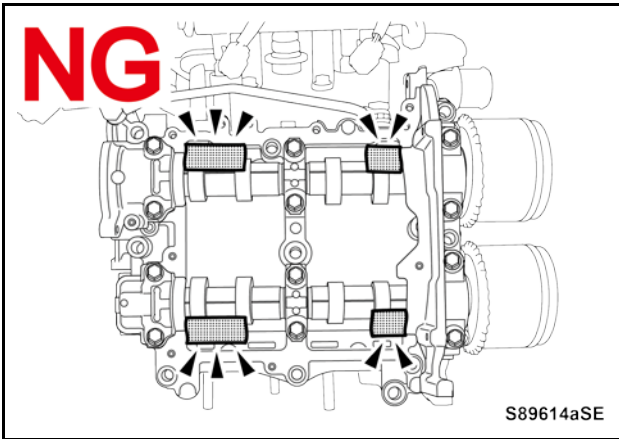

### 1. REINSTALL CYLINDER HEAD COVER SUB-ASSEMBLY RH

#### NOTE:

The cylinder head cover sub-assembly RH is sealed by combination of the rubber gasket and the seal packing.

- a) Make sure that all pieces of cloth have been removed from the cylinder heads.

- b) Clean and degrease the contact surfaces of the cylinder head cover assembly and the mating part.

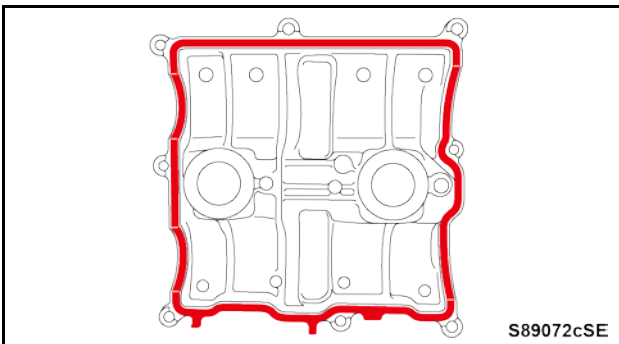
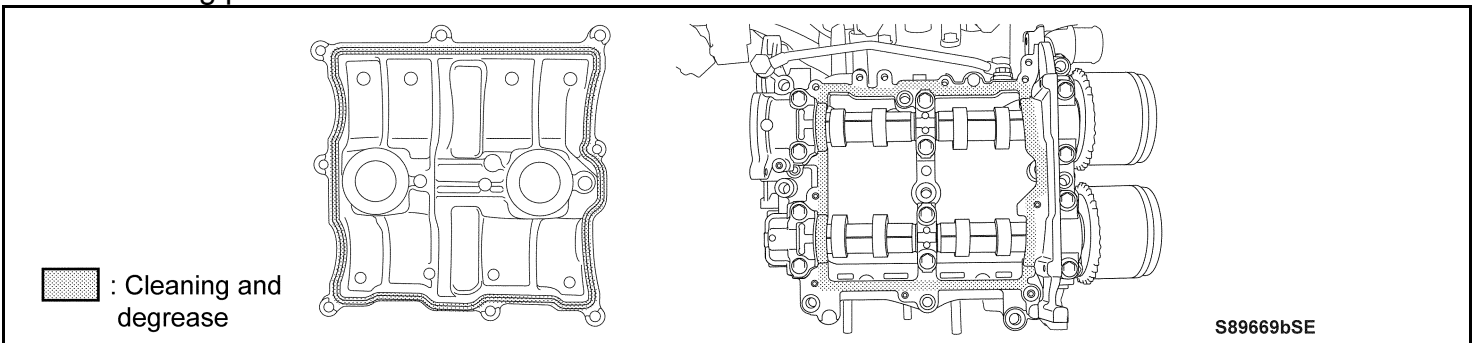

- c) Install a **NEW** rubber gasket.



- d) Remove the seal packing, which has got hard, from the tip of the sealer gun.
- e) Apply seal packing to the **NEW** rubber gasket in the specified locations.



- **DO NOT** apply seal packing to the areas other than specified (2 seal packing prohibited areas), or oil leaks may occur.
- Each component must be attached within 5 minutes of seal packing application, and all bolts must be tightened to the specified torque within 15 minutes of the application.

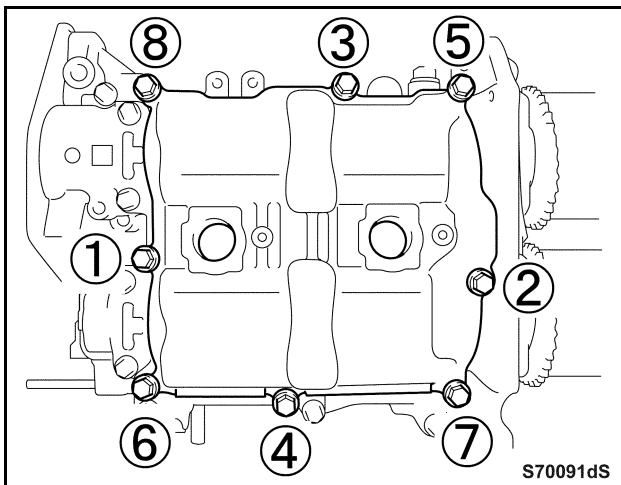
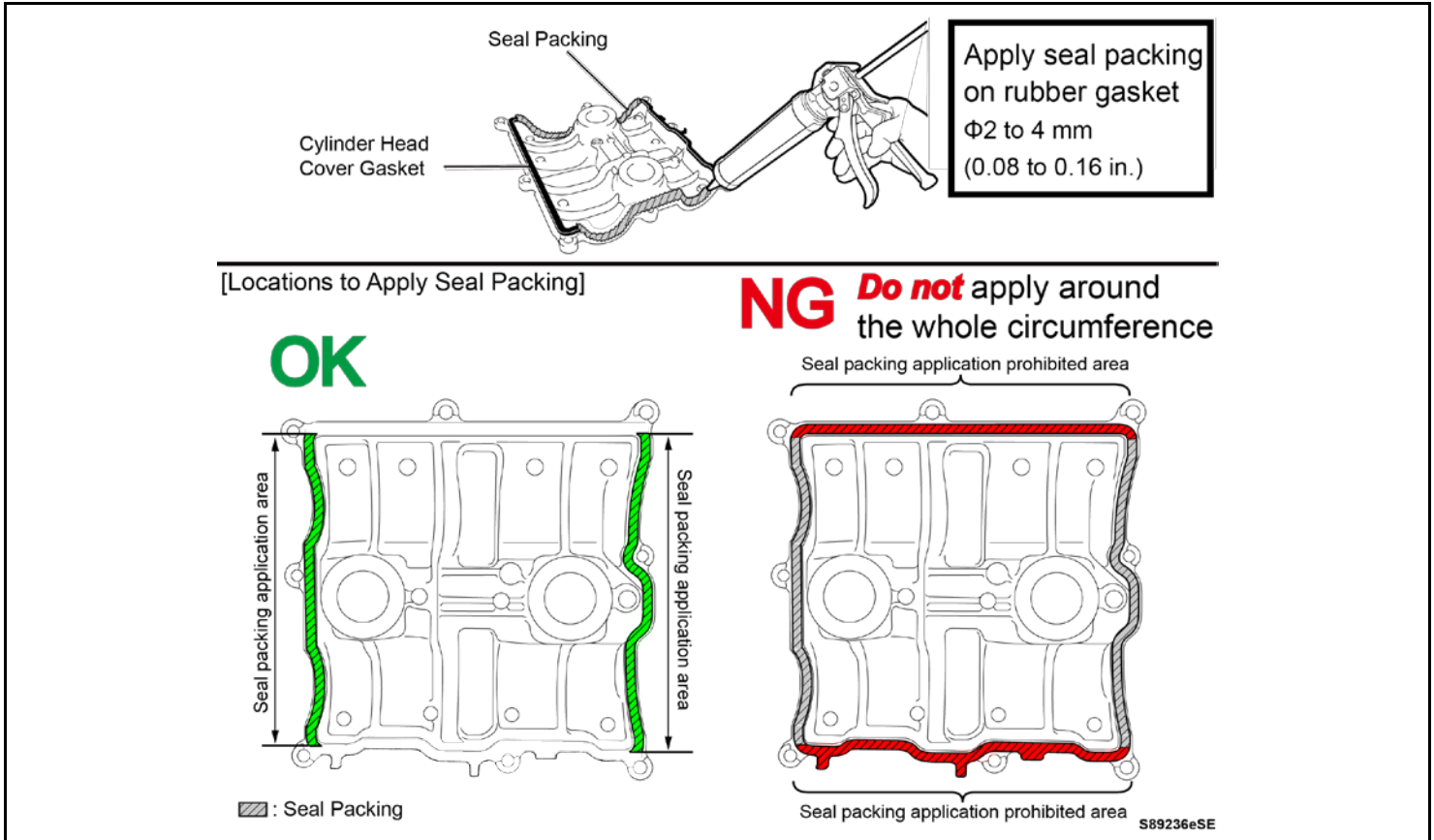

- f) Set the cylinder head cover RH, and install it by uniformly and gradually tightening the 8 bolts in the specified order in several passes.

**Specified torque:**

**57 in.\*lbf (6.4 N\*m, 65 kgf\*cm)**

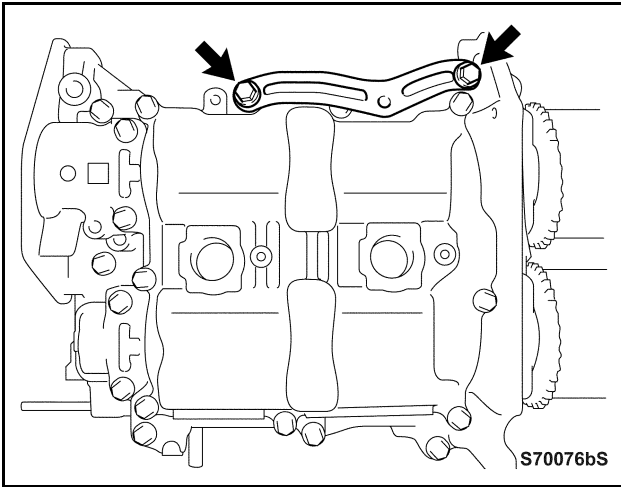

## 2. REINSTALL INJECTOR DRIVER BRACKET

- a) Install the injector driver bracket with the 2 bolts.

**Specified torque:**

**57 in.\*lbf (6.4 N\*m, 65 kgf\*cm)**

## XV.REMOVAL OF CYLINDER HEAD COVER (LH BANK)

### 1. OPERATE ENGINE STAND

- a) Place a tray to catch the oil that will flow out from the engine.

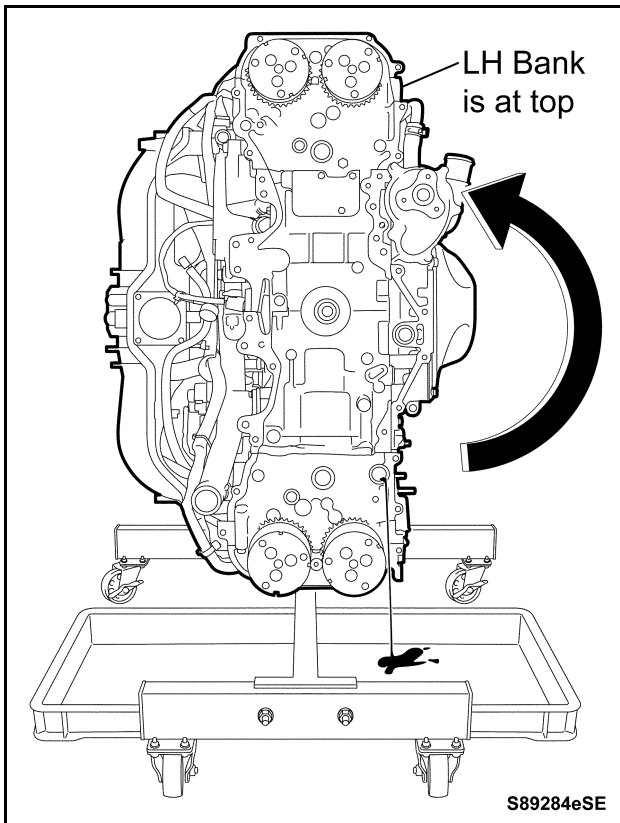

- b) Rotate the engine stand until the LH Bank (No. 2 and No. 4 cylinders) is at top.

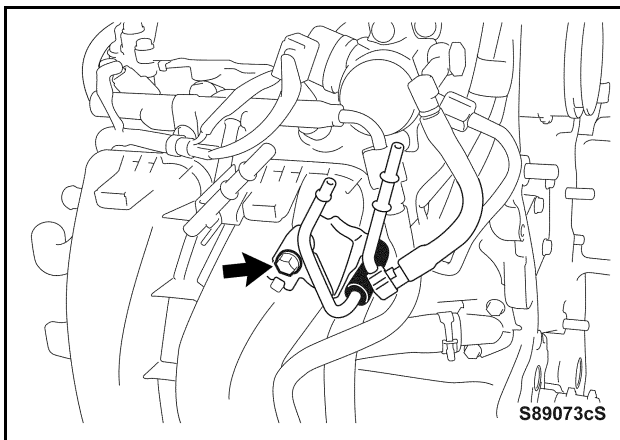

### 2. DISCONNECT FUEL DELIVERY PIPE SUB-ASSEMBLY

- a) Remove the bolt from the fuel delivery pipe sub-assembly.
- b) Disconnect the fuel hose.

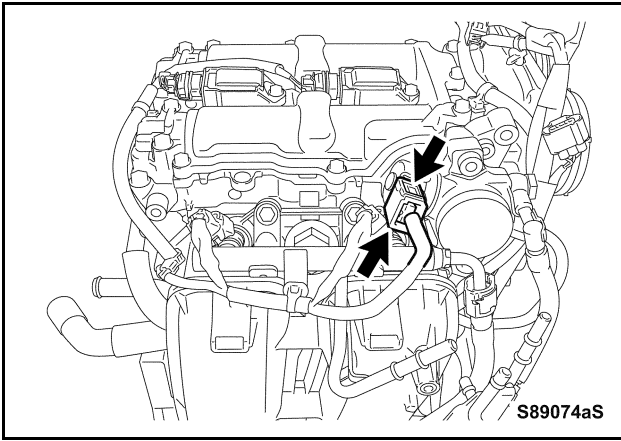

### 3. REMOVE FUEL DELIVERY PIPE SUB-ASSEMBLY

- a) While pressing the claws on the fuel pump connector from both sides, disconnect the connector.

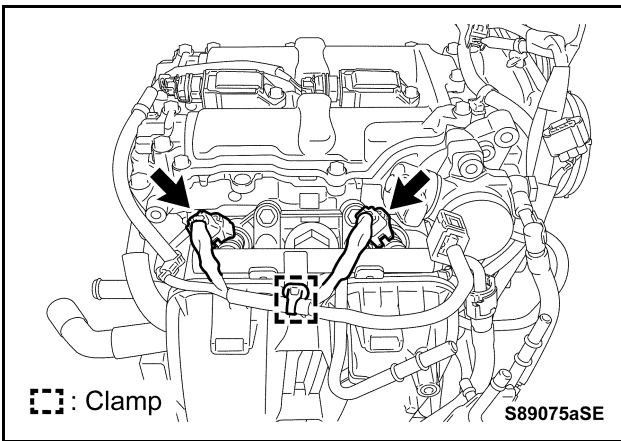

- b) Disconnect the 2 connectors.
- c) Disengage the wire harness clamp by pressing the claws inward from behind.

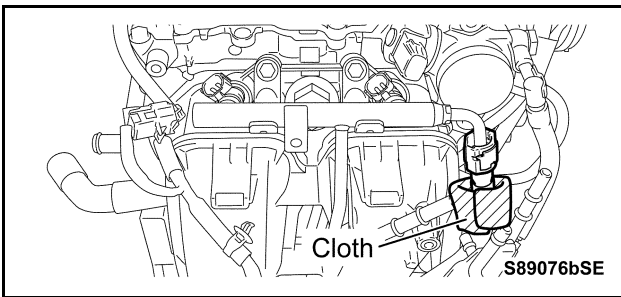

- d) Wrap cloth under the area where the pipes are being disconnected to catch the fuel that will trickle out.

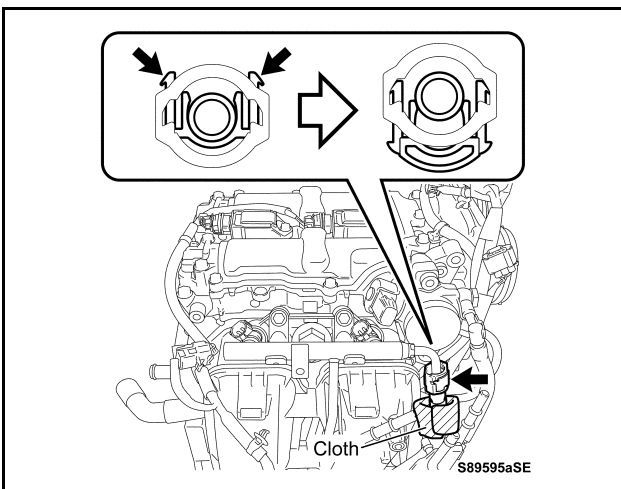

- e) Press in the claws by fingers to disengage and disconnect the No. 2 fuel delivery pipe.

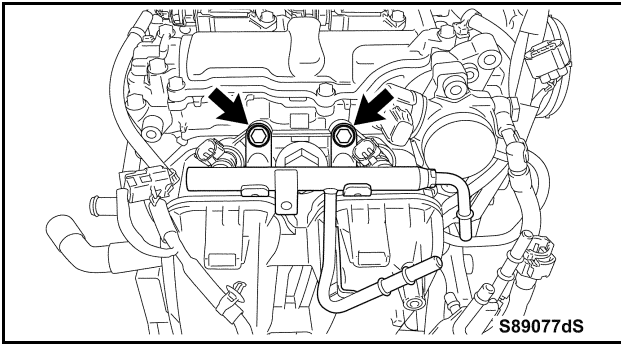

f) Remove the 2 bolts.

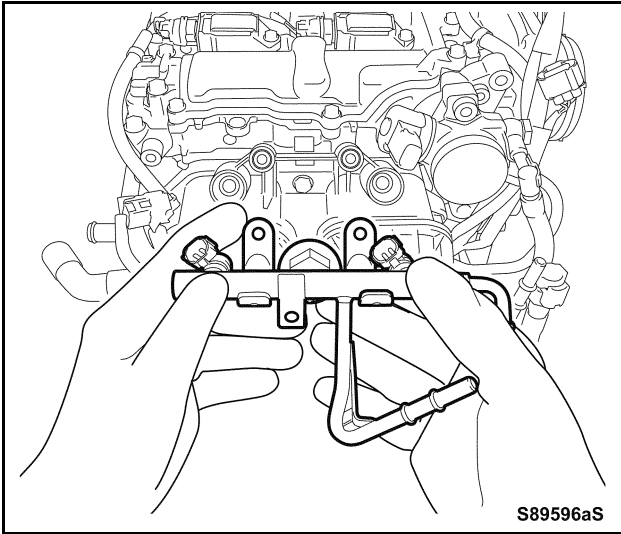

g) While holding the delivery pipes and the injector firmly in one, pull out the injector from the intake manifold.



- **DO NOT** separate the injectors from the delivery pipe even during storage.
- **DO NOT** pull on only the delivery pipe when pulling out the injector, as it will separate.
- If an injector detaches from the delivery pipe, replace the O-ring and the grommet with **NEW** ones included in the Valve Spring Kit.

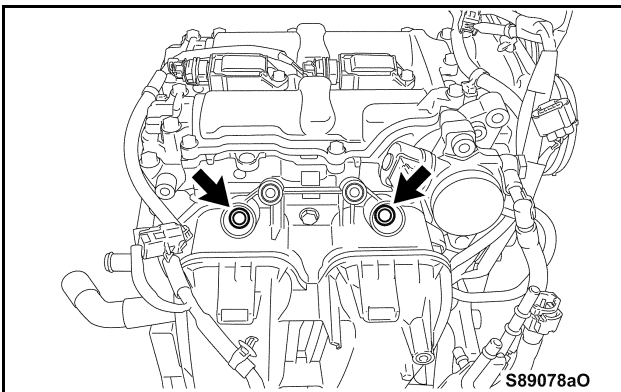

h) Using a flathead screwdriver with its tip wrapped in protective tape, remove the 2 injector seals.

i) Destroy the removed injector seals, and then store them in a separate container so as not to reinstall them in errors.

j) Cover the injector holes with protective tape, to prevent insertion of foreign matters.

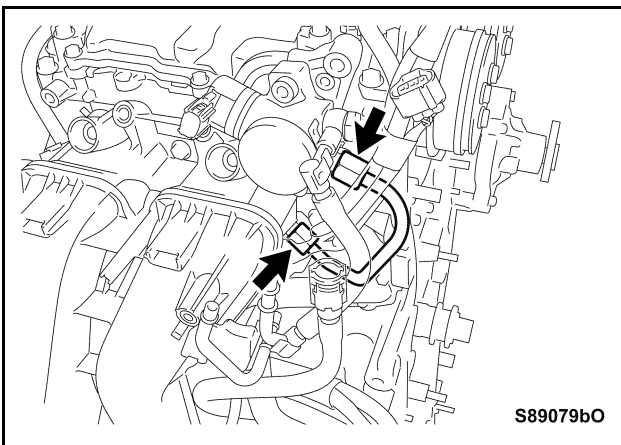

#### 4. REMOVE NO. 2 FUEL DELIVERY PIPE

a) Using a 17 mm (0.67 in.) union nut wrench, remove the No. 2 fuel delivery pipe.



**Be sure to pull the delivery pipe straight when removing it, or damage to the sealing surfaces may occur.**

b) Mark and store the removed No. 2 fuel delivery pipe in a separate container so as not to reinstall it in error.

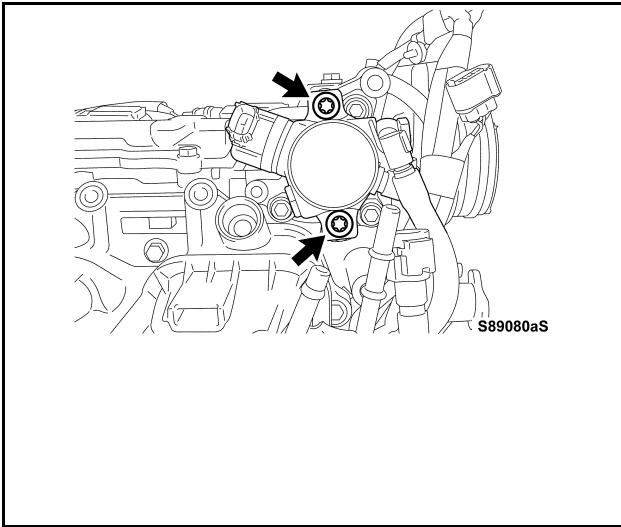

**5. REMOVE FUEL PUMP ASSEMBLY**

- a) Using the “Torx” Plus 40IP socket wrench, uniformly and gradually loosen the 2 bolts, avoiding the fuel pump to tilt so as not to apply excessive force to the fuel pump.

**NOTE:**

**The fuel pump is pushed upward when the bolts are loosened.**

- b) Remove the O-ring.
- c) Destroy the removed O-ring, and then store it in a separate container so as not to reinstall it in error

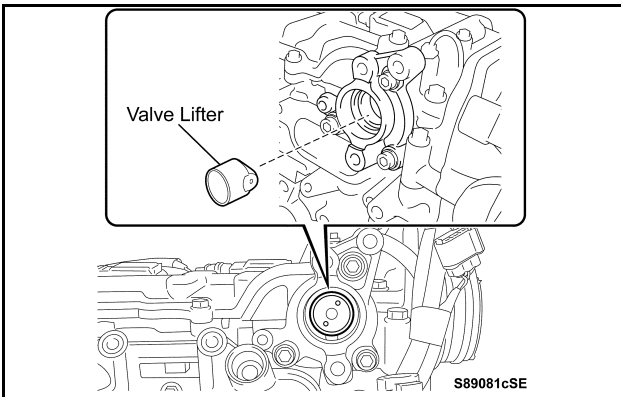

**6. REMOVE VALVE LIFTER (for Fuel Pump)**

- a) Remove the valve lifter from the pump drive case assembly.

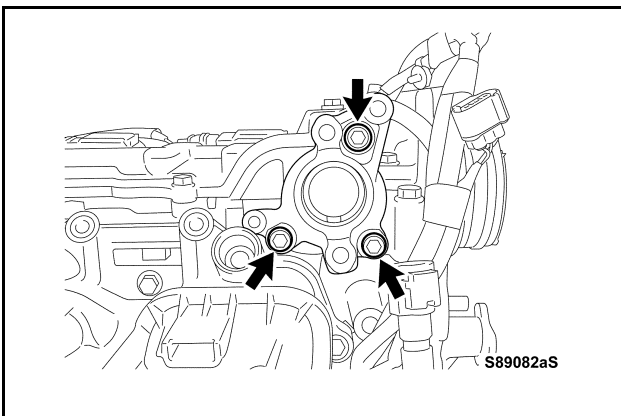

**7. REMOVE PUMP DRIVE CASE ASSEMBLY**

- a) Using a 6 mm (0.24 in.) hexagon socket, remove the 3 bolts.
- b) Using a flathead screwdriver with its tip wrapped in protective tape, pry to remove the pump drive case assembly as it is adhered with seal packing.



**DO NOT damage the contact surfaces with the tool.**