

TITLE: Inspection for Incorrect brake flange orientation		
AFFECTED SITE(s): P61 – DEXTER/FOREST RIVER		DEPARTMENT(s): Quality
Written By: Sean Cantzler	Approved By: Aldijana Custovic	Revision Date: 9/13/18

PURPOSE:

To inspect brake flange orientation on a 22.5 degree down Torflex axle, and if out of specification, replace axle with correct brake flange orientation.

MATERIALS:

- 1) 4 bolt brake flange Template used with axle models #10F&H. These axles have hubs with 5 lug nuts.
- 2) 5 bolt brake flange Template used with axle model #11. These axles have hubs with 6 lug nuts.

Safety Note:

Secure the trailer according to the Forest River Maintenance/Repairs Manual.

Do not jack the trailer up on the axle tube.

- 1) Identify unit(s) needing to be inspected based on the production dates provided by Forest River.

If the brake flange is found to be out of specification, the axle must be replaced.

- 2) The spindle/Brake Flange must be oriented correctly in order for the brake to function properly. Detail below for the 4 bolt brake flange proper orientation

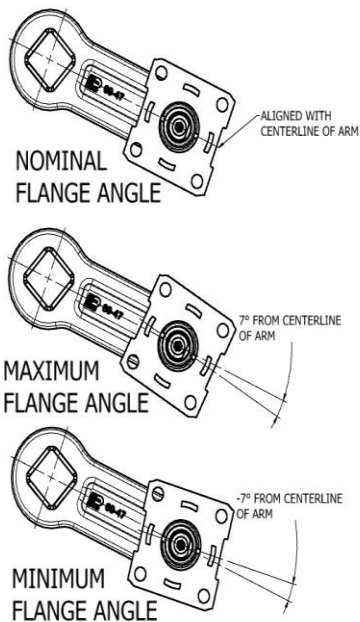

Detail below for the 5 bolt brake flange proper orientation

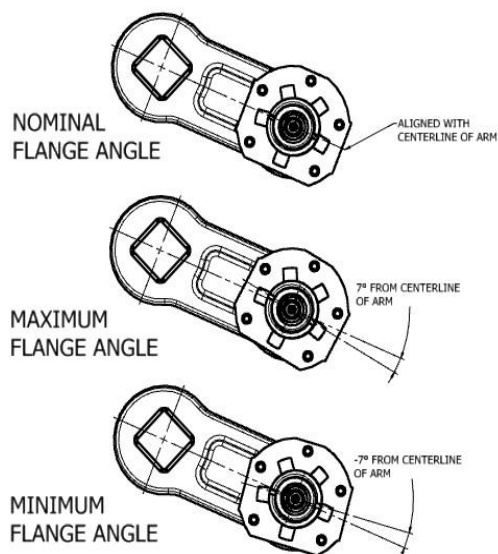

3) A Template has been provided for the 4 bolt flange. Place the 4 bolt template on the top of the Torsion Arm. If the Top of the mounting flange is fully visible in the cutout the flange is oriented correctly.

4) If the Top of the brake flange is not fully visible, the flange orientation is out of specification. **The axle must be replaced.** Proceed to step 7

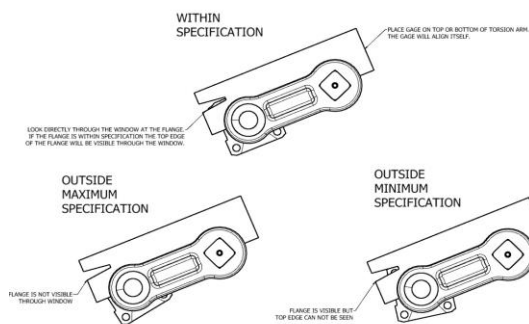

5) To use the five bolt flange template, follow the instructions to the right.

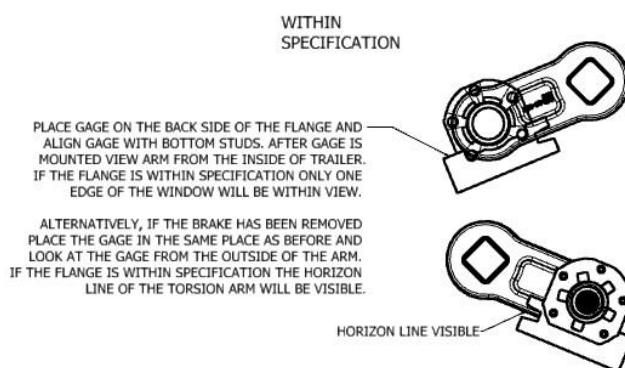

6) An out of specification brake flange orientation will result in a view of the template similar to the pictures on the right. **The axle must be replaced.**

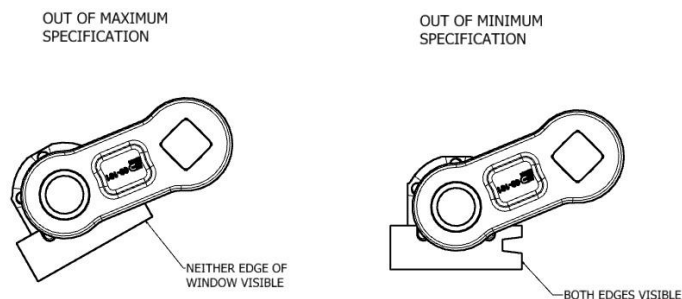

If an out of specification brake flange is found during the inspection, the axle must be replaced.

7) Remove and replace the axle according to the Forest River Maintenance/Repair Process

Revision History:

Level	Date	Reason for change	Writer	Approval
SW-2	9/13/18	New Issue	SC	AC