

Motorcycle/ATV Division

SP/DR/GN/GZ/LS No. 065

July 6, 2018

## **SAFETY RECALL CAMPAIGN 2A84**

### **DR-Z400S/SML8 Rear Brake Stop Lamp Switch Replacement**

**Affected Models:** 2018 DR-Z400S/SM

**Affected Departments:** Management, Service, Sales, Warranty, Parts, Accessories

This notice is sent to you in accordance with the requirements of the National Traffic and Motor Vehicle Safety Act.

Suzuki Motor Corporation has decided that a defect which relates to motor vehicle safety exists in certain 2018 Suzuki DR-Z400S/SM motorcycles.

#### ***STOP DELIVERY OF AFFECTED MOTORCYCLES***

*Issued by Suzuki Motor of America, Inc. on June 22, 2018*

**DO NOT SELL OR DELIVER** an affected motorcycle to a customer until you have completed, or verified completion of, the repair procedures outlined in this bulletin.

**It is a violation of Federal law to sell or deliver any new motorcycle or item of motor vehicle equipment subject to a safety recall campaign under a sale or lease until the defect or non-compliance has been corrected.**

**In addition, selling an unrepaired affected motorcycle is a direct violation of your Suzuki dealer agreement and may lead to additional sanctions.**

#### **What is the problem?**

During the manufacturing process, the resin used to fill the rear brake stop lamp switch assembly may have adhered to the internal contacts, resulting in poor conductivity and preventing the stop lamp from illuminating when only the rear brake is applied. Failure of the brake stop lamp to illuminate may increase the risk of a rear crash. To ensure customer safety and satisfaction, Suzuki is replacing the rear brake stop lamp switch assembly.

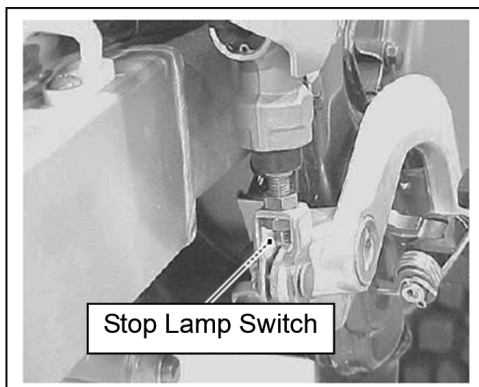

**What your dealership will do:**

Install a replacement rear brake stop lamp switch assembly as outlined in this Technical Service Bulletin, and submit a warranty claim for reimbursement.

Affected Models	Model Year	VIN Range
DR-Z400S	2018	JS1SK43A_J2100242 ~ JS1SK43A_J2100312
DR-Z400SM	2018	JS1SK44A_J2100430 ~ JS1SK44A_J2100549

**Verify if the motorcycle is affected by the safety recall:**

Before performing the recall repair on a motorcycle, first verify the repair needs to be performed by accessing the Vehicle Master Inquiry on Suzuki Connect and checking the repair status. If the repair needs to be performed, you will see the message “CAMPAIGN NOT YET PERFORMED.” If you have a question regarding motorcycle eligibility, contact your Suzuki Technical Service Manager (TSM) or call Tech-Line at (714) 996-7480.

**What Suzuki Motor of America, Inc. (Suzuki) will do:**

During the week of July 16, 2018, Suzuki will mail notifications to owners of affected motorcycles for whom we have information. The notice instructs the customer to contact a Suzuki dealer to schedule an appointment for the repair.

If you have sold an affected motorcycle to a customer prior to receiving this bulletin, contact the customer immediately to arrange for the vehicle to be returned to your dealership for this safety recall campaign repair.

**Ordering parts for the Safety Recall Campaign:**

Parts are available for order now via Suzuki Connect with the required last nine digits of the VIN at the time of order. Please note the following:

1. These recall campaign parts can be ordered using the following methods:
  - Daily Stock Order (Freight Prepaid)
  - Critical Order (Surcharge applies based on the shipping method selected)
2. Each campaign part on the order must be placed on a separate line along with the last 9 digits of the VIN entered into the memo field.

Order Type	Daily Stock	
Total Amount	Total Qty	
Part Number	Qty	Memo
37740-29F00-RX0	1	4J2100312

3. Suzuki’s Parts Department will verify the VIN is affected by the recall campaign.
4. Following verification, the order will be processed, and the VIN entered on the parts order form will be displayed in the Sales Order Comments field on the packing list.
5. Your parts order shipment may be delayed due to the verification process.
6. Due to campaign parts being on restricted release, campaign parts will be listed as Back Ordered when checking Parts Availability on Suzuki Connect.

**PARTS ORDERING INFORMATION**

Part Name	Part Number	Quantity Required
Switch Assy, Stop Lamp	37740-29F00-RX0	1

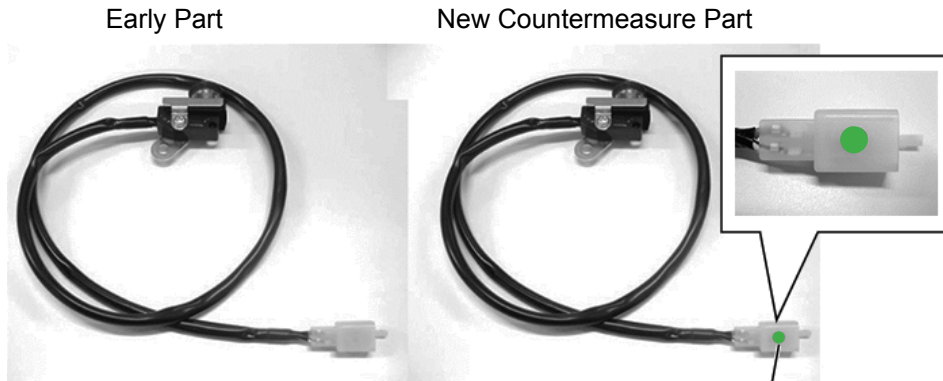

*The new countermeasure part can be identified by the green paint mark on the lead wire coupler.*

**Warranty Claim Processing:**

Submit a warranty claim for each campaign repair immediately upon completion. This campaign requires you to file a warranty claim using ONE of the methods described below.

**Suzuki Connect Short Campaign Claim:** A Short Campaign Claim will reimburse you for replacement of the stop lamp switch assembly and 0.7 hour labor.

**CAMPAIGN 2A84 STOP LAMP  
SUZUKI CONNECT SHORT FORM INSTRUCTIONS**

CLAIM INFORMATION	
CLAIM NUMBER:	XXXXX,X (Dealer enters number)
ENTRY TYPE:	VIN, Model/Frame or Control/Sequence # (Dealer chooses)
REPAIR DATE:	Enter date of repair
MILEAGE:	Enter mileage at repair date
CAMPAIGN NUMBER:	2A84

(Continued)

**Suzuki Connect Long Campaign Claim:** A Long Campaign Claim will reimburse you for replacement of the stop lamp switch assembly, 0.7 hour labor, and additional parts and labor only as authorized by your Suzuki TSM.

<b>CAMPAIGN 2A84 STOP LAMP SUZUKI CONNECT LONG FORM INSTRUCTIONS</b>	
<b>CLAIM INFORMATION</b>	
CLAIM NUMBER:	XXXXX,X (Dealer enters number)
ENTRY TYPE:	VIN, Model/Frame or Control/Sequence # (Dealer chooses)
REPAIR DATE:	Enter date of repair
MILEAGE:	Enter mileage at repair date
CAMPAIGN NUMBER:	2A84
LABOR TIME (Choose one):	0.7 Hour
<b>PARTS INFORMATION</b>	
REPLACEMENT PART:	37740-29F00-RX0 (Qty 1)
ADDITIONAL PARTS:	Additional parts as authorized by your TSM
AUTHORIZATION:	Only needed if additional parts or labor claimed
<b>FAILURE DESCRIPTION</b>	
DESCRIPTION OF DEFECT:	Stop Lamp Switch Assembly Replacement
DESCRIPTION OF REPAIR	Performed recall repair as required per Service Bulletin

<b>WARRANTY INFORMATION</b>				
Model	Spec	Part Desc.	Part Number	Campaign Number
DR-Z400S/SM	E03 (FED)	Switch Assy, Stop Lamp	37740-29F00-RX0	2A84

**Repair Procedure:**

**NOTE:**

For any procedure not outlined in this Technical Service Bulletin, refer to the DR-Z400S/SM Service Manual, P/N 99500-43092-03E.

**Stop Lamp Switch Removal**

1. Remove the seat. (Refer to *Service Manual Section 6-2, Exterior Parts.*)
2. Remove the left frame cover. (Refer to *Section 6-2, Exterior Parts.*)
3. Disconnect the negative battery (-) lead wire. (Refer to *Section 7-34, Battery.*)
4. Remove the engine plate. (Refer to *Section 3-3, Engine Removal and Remounting.*)
5. Remove the water pump guard (1).

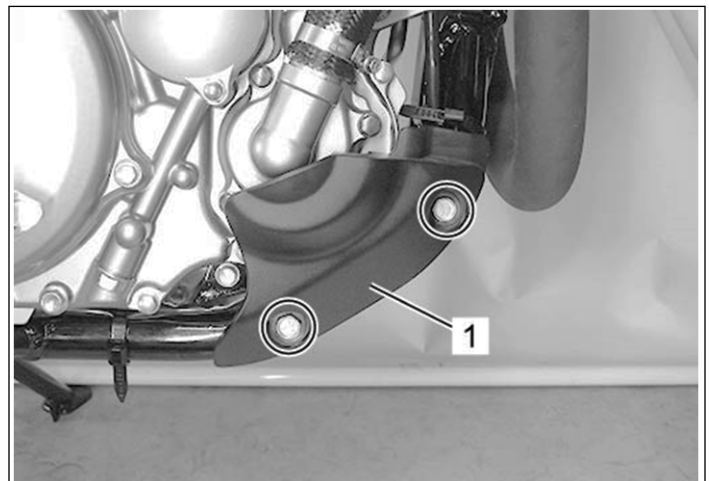

6. Remove clamps (1), (2) and (3).

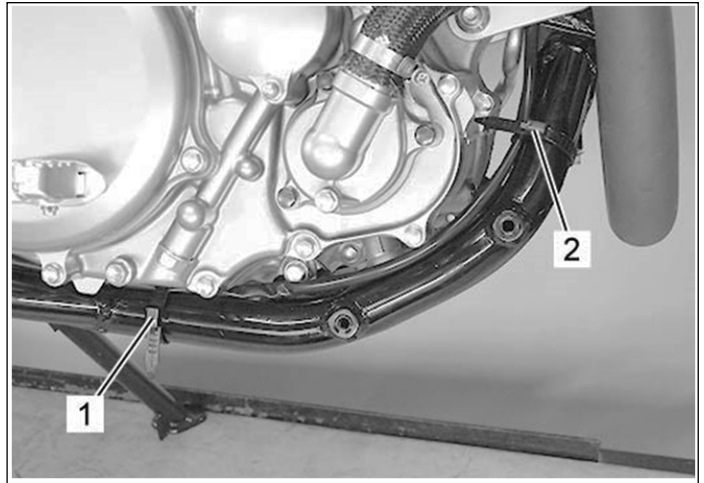

7. Disconnect the rear brake stop lamp switch lead wire coupler (1).

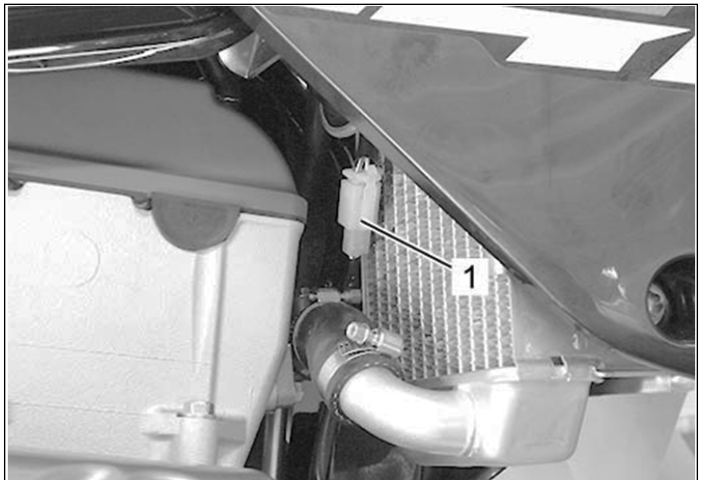

8. Cut the rear brake stop lamp switch lead wire.

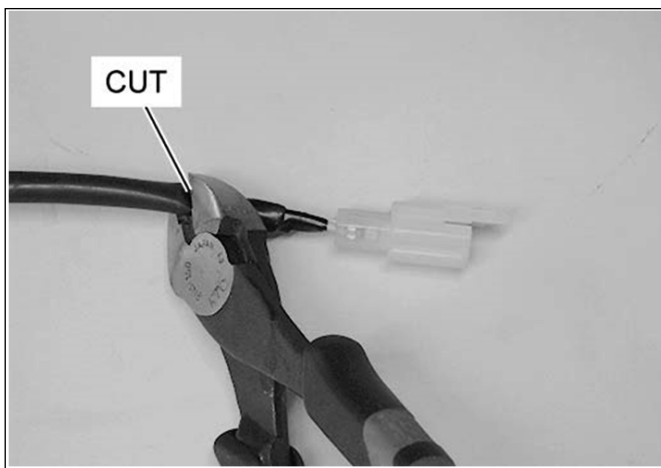

9. Remove the rear brake stop lamp switch (1).

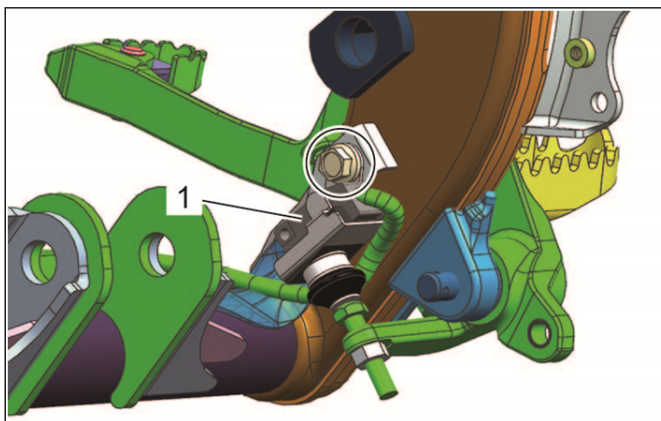

### Stop Lamp Switch Installation

1. Before installing the new rear brake stop lamp switch, position the lead wire as shown.

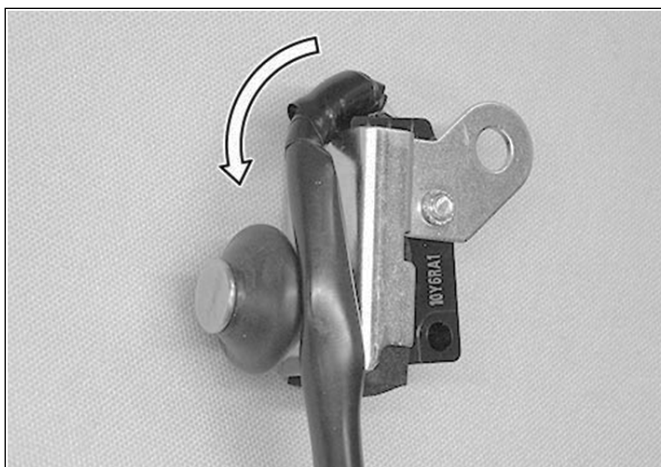

2. Install the new rear brake stop lamp switch (1) on the frame.

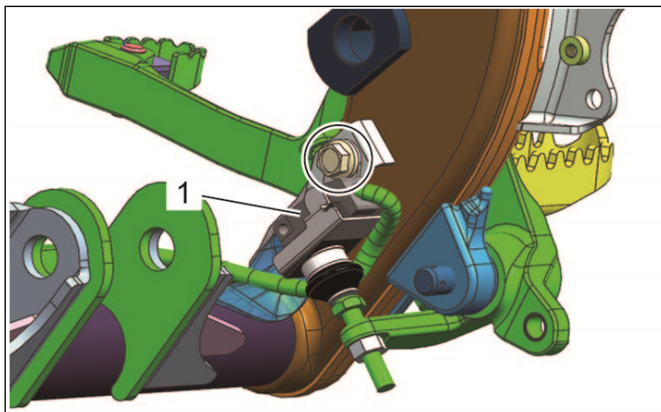



3. Pass the rear brake stop lamp switch lead wire according to the following procedure.

a) Pass the lead wire coupler (1) between the crankcase (2) and cushion lever (3).

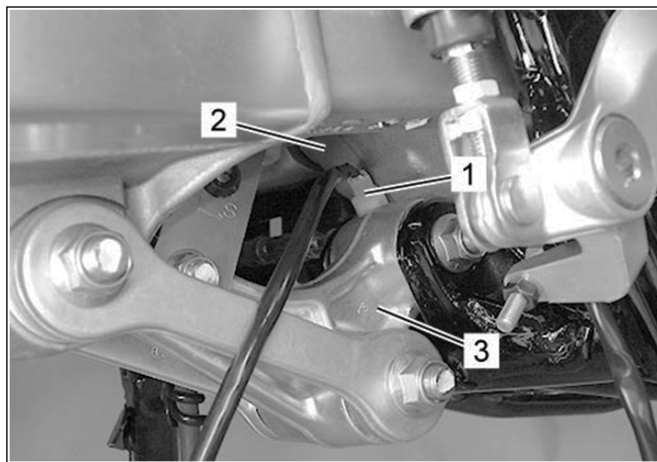

b) Pass the lead wire coupler (1) above the frame bridge left side (2).

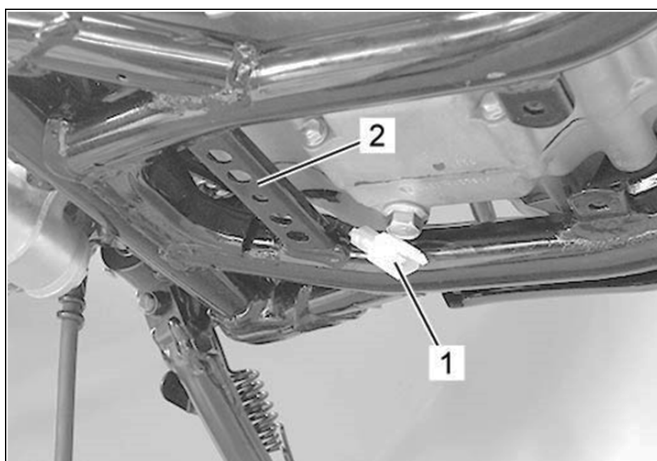

c) Draw the lead wire coupler (1) from behind the engine mounting lower bracket (2).

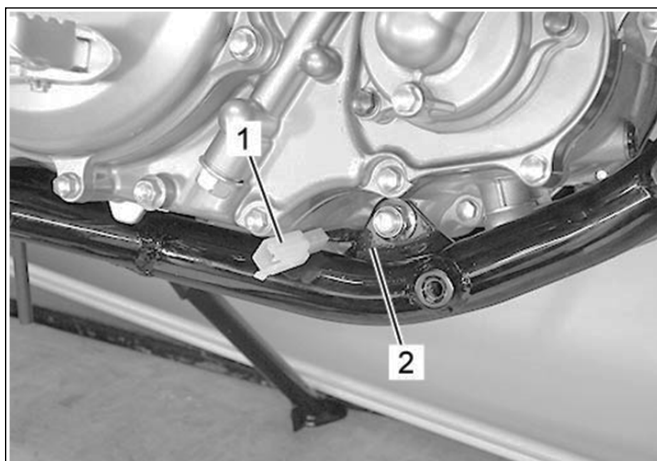

d) Draw the lead wire (1) from under the clutch cover (2).

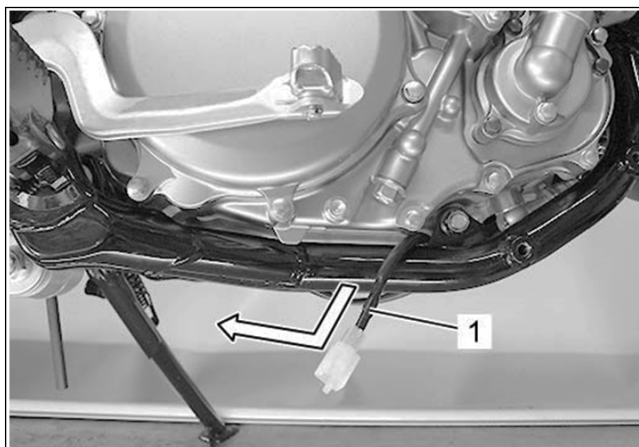



e) Pass the lead wire along the frame upper side, then pass the coupler (1) inside the right engine mounting front plate (2).

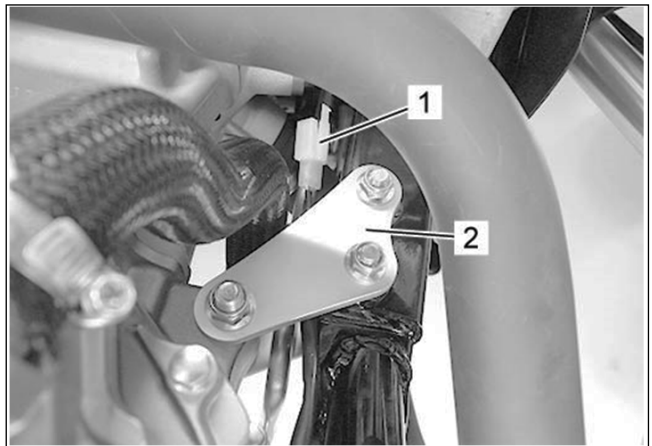

f) Pass the switch lead wire coupler (1) through the left side of the thermostat case (2).

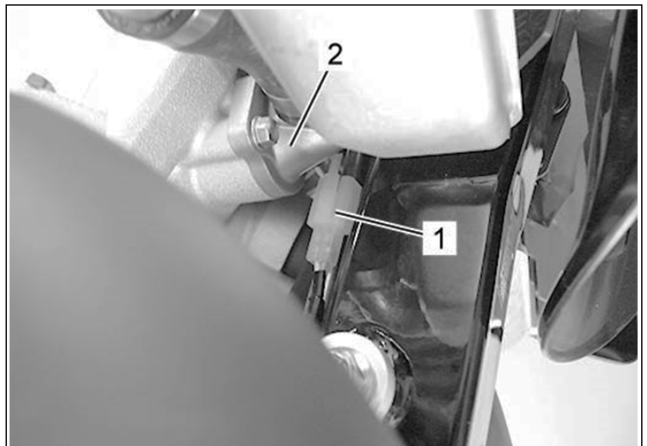

4. Connect the switch lead wire coupler (1).

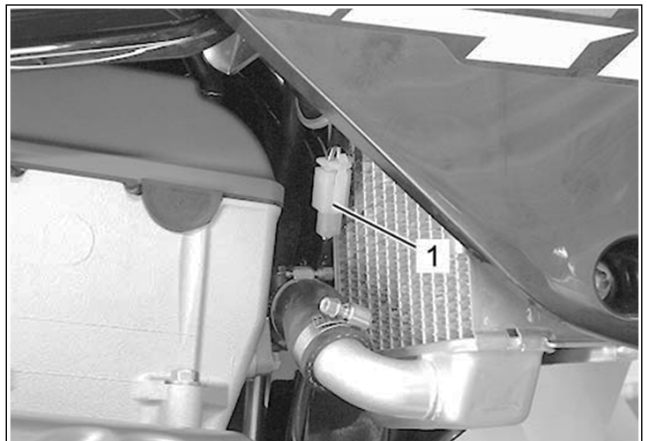



5. Confirm the rear brake stop lamp switch and the lead wire are positioned correctly, and secure clamps (1), (2) and (3).

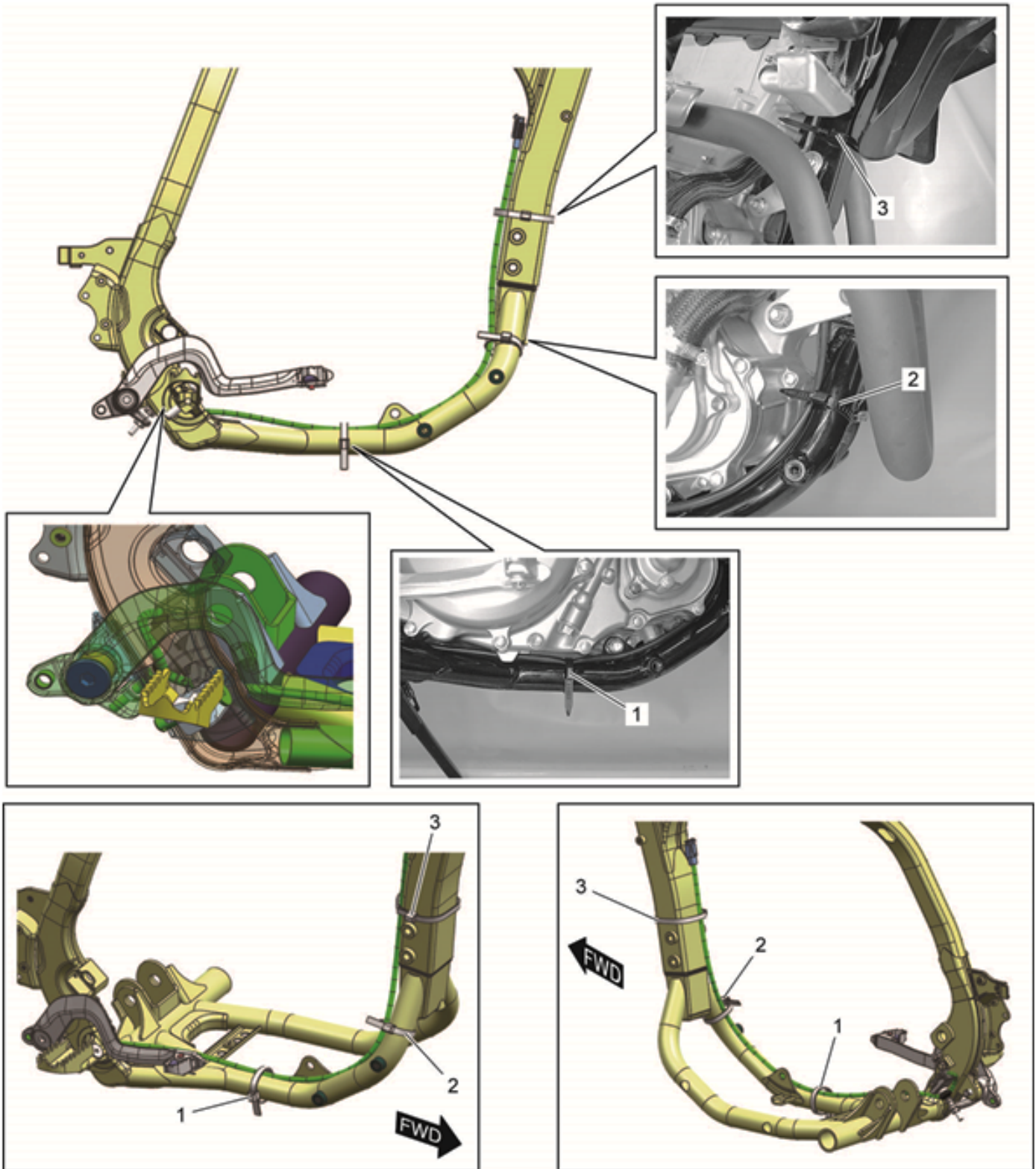

6. Connect the negative battery (-) lead wire.  
7. Install all removed parts in the reverse order of removal.  
8. Be sure each part is properly positioned in the assembly and secure.  
9. Confirm the rear brake stop lamp functions correctly.



SUZUKI MOTOR OF AMERICA, INC.

## IMPORTANT SAFETY RECALL

This Notice Applies to Your Suzuki Vehicle Identification Number (VIN)

July 16, 2018

Dear Suzuki Owner:

This notice is sent to you in accordance with the requirements of the National Traffic and Motor Vehicle Safety Act.

Suzuki Motor Corporation has decided that a defect which relates to motor vehicle safety exists in certain 2018 Suzuki DR-Z400S/SM motorcycles.

### **What is the problem?**

During the manufacturing process, the resin used to fill the rear brake stop lamp switch assembly may have adhered to the internal contacts, resulting in poor conductivity and preventing the stop lamp from illuminating when only the rear brake is applied. Failure of the stop lamp to illuminate may increase the risk of a rear crash. To ensure customer safety and satisfaction, Suzuki is replacing the rear brake stop lamp switch assembly.

### **WARNING**

**Operating your motorcycle without having the recall service performed may increase the risk of a crash.**

**If you must ride your motorcycle before this safety recall service has been completed, be aware that the stop lamp may not illuminate if you use only the rear brake pedal. Apply the front and rear brakes together as outlined in your Suzuki Owner's Manual.**

### **What is Suzuki Motor of America, Inc. doing to solve the problem?**

Your dealer will replace the rear brake stop lamp switch assembly. This procedure will take approximately one hour to complete. Parts are available now, and there will be no charge to you for this recall repair, parts and labor.

### **What you should do:**

- Before taking your motorcycle to your dealer, contact them to set up an appointment for the recall repair.
- We suggest that you bring this letter and the enclosed card to your dealer to help your dealer process your claim.
- If you have additional questions, please visit <http://www.suzukicycles.com/recalls.aspx> to read the *2018 DR-Z400S/SM Rear Brake Stop Lamp Safety Recall Frequently Asked Questions*.

### **What to do if you receive this notice in error:**

This notice was mailed to you according to the latest information that is available to us. If you no longer own the Suzuki motorcycle described in this notice, please complete and return the attached Change of Address/Ownership card to Suzuki Motor of America, Inc., and forward this recall information to the current owner (if known).

Federal regulations require that any vehicle lessor receiving this recall notice must forward a copy of this notice to the lessee within ten days.

**Customer reimbursement for repairs prior to this Safety Recall Notification:**

If your motorcycle is included in this recall and you have paid for repairs to address the defect that led to this recall, you may be eligible for full or partial reimbursement. Please note the following conditions for reimbursement:

- Only repairs made to address the defect that led to this recall are reimbursable. Additional expenses such as towing, car rental, accommodations, damage repairs, etc., will not be reimbursed. Reimbursement will not be provided for routine scheduled maintenance.
- Reimbursement may be limited to the suggested list price for parts, the Suzuki published flat-rate time allowance for the repair, and the labor rate that an authorized Suzuki dealer in the same area would charge for the same repair.
- An owner will not be eligible for reimbursement if the expenses for repairs are incurred more than 10 days after the date of this notice.
- Reimbursement claims may also be excluded when adequate documentation is not submitted by the claimant. This includes a proof of ownership, a repair order, and proof of payment for the repair.

To apply for reimbursement:

- 1) Go to [www.suzukicycles.com](http://www.suzukicycles.com).
- 2) Select Safety Recalls at the lower right side of the home page.
- 3) When the page refreshes, select Recall Notification Letters.
- 4) Select *2018 DR-Z400S/SM Rear Brake Stop Lamp Replacement Reimbursement*.

**Who to contact if you experience problems:**

Your Suzuki dealer can provide you the fastest response to your questions or concerns about this safety recall campaign. If you have any difficulty with this recall campaign, you may contact the Suzuki Motor of America, Inc., Customer Service Department for assistance at (714) 572-1490 during the hours of 7:00 AM to 4:30 PM Pacific Time. Please have your vehicle identification number (VIN) ready when calling.

If you need to locate your nearest Suzuki Motorcycle Dealer, please visit [www.suzukicycles.com](http://www.suzukicycles.com) and click on the "FIND A DEALER" tab, which is located in the upper right corner of our website.

If you believe that Suzuki Motor of America, Inc., has failed to provide the safety recall campaign service without charge or is unable to do so within a reasonable time, you may submit a complaint to the Administrator of the National Highway Traffic Safety Administration, 1200 New Jersey Ave., S.E., Washington D.C., 20590 or call the toll-free Vehicle Safety Hotline at 1-888-327-4236 (TTY: 1-888-424-9153) or go to [www.safercar.gov](http://www.safercar.gov).

We apologize for any inconvenience this recall campaign causes you. We hope you understand that your safety and satisfaction are important priorities for us.

Sincerely,

Suzuki Motor of America, Inc.