

Vehicle Safety Recall - Technical Service Bulletin

PROMPT ACTION REQUIRED

Attention: McNeilus Product Owner
Subject: Bridgemaster V nylon reservoir filler neck replacement
Model Affected: Bridgemaster V 93
Model Years: 2008-2018
Date: June 2018

Purpose:

McNeilus Truck and Manufacturing, Inc. has decided that a concern affecting safety exists in some McNeilus Bridgemaster V vehicles. Changing the filler neck component on certain nylon hydraulic oil reservoirs will improve venting of the reservoir which will help prevent failure/leaking of the reservoir.

Affected Vehicles:

The affected vehicle population is McNeilus Bridgemaster V mixers with nylon hydraulic oil reservoirs, produced between 2008-2018. Please refer to the attached VIN list of affected vehicles.

Time Completion:

Upon receipt of the parts, complete the enclosed Bridgemaster filler neck replacement procedure for each affected unit. The time of accomplishment may vary due to a number of factors; however, the estimated time for completion of the procedure is 1.0 hour under normal circumstances.

Required Action:

Review and verify your ownership of all affected serial numbers of McNeilus vehicles. If McNeilus records indicate that you are the owner of one or more affected units, a Serial Number List is enclosed. **Please be reminded that it is a violation of Federal law for you to sell or lease the trucks covered by this notification until this recall has been performed on these vehicles. Substantial civil penalties apply to violations of this law.**

Reimbursement of Costs:

Affected units shall be repaired using the customer’s own qualified service technicians - at no cost to the owner. The repairs should take approximately 1.0 hour.

Labor Reimbursement:

In order to receive credit, claims are to be submitted through the normal warranty claim system. Claims must be received within 30 days of the repair. Claims must include the McNeilus serial number of the truck, the customer asset number, and the number of this bulletin.

Parts Reimbursement:

Parts and ground shipping will be reimbursed to the customer. Parts necessary for this repair must be ordered from McNeilus Parts at 888-686-7278.

Claims are to be submitted through the normal warranty claim system. Claims must be received within 30 days of the repair. Claims must include the McNeilus serial number of the truck, the customer asset number, and this bulletin’s number.

Contacts:

If you have questions or need further information, please contact a McNeilus National Service Representative at 888-686-7278.

Enclosures:

- Filler neck replacement procedure
- VIN list of affected vehicles

SAFETY NOTICE
Perform your company’s Lockout/Tagout procedure. If your company does not have a Lockout/Tagout procedure, follow OSHA 1910.147 and 1910.146 Confined Space as appropriate.

SAFETY NOTICE
Use appropriate Personal Protective Equipment (PPE) as required by your company.

PROCEDURE: Filler neck replacement

Tools and Equipment Required (Customer to supply own):

- 1-7/16" wrench
- Hydraulic oil collection container (if needed)

Parts Required (Purchase from McNeilus):

Item	Part Number	Description	Qty.
1	1570075	NECK, NYLON RESERVOIR, BREATHER/FILL PORT	1
2	1320953	BREATHER, FILLER NYLON CAP (IF NECESSARY)	1
3	1564389	SIGN, SAFETY WARNING, HYD FILL	1

1. Place unit on a flat surface, block truck tires, and perform your company's Lockout/Tagout procedure. If your company does not have a Lockout/Tagout procedure, follow OSHA 1910.147 and 1910.146 Confined Space as appropriate.
2. Use the wrench to unscrew the existing filler neck from the nylon reservoir (Figure 1).

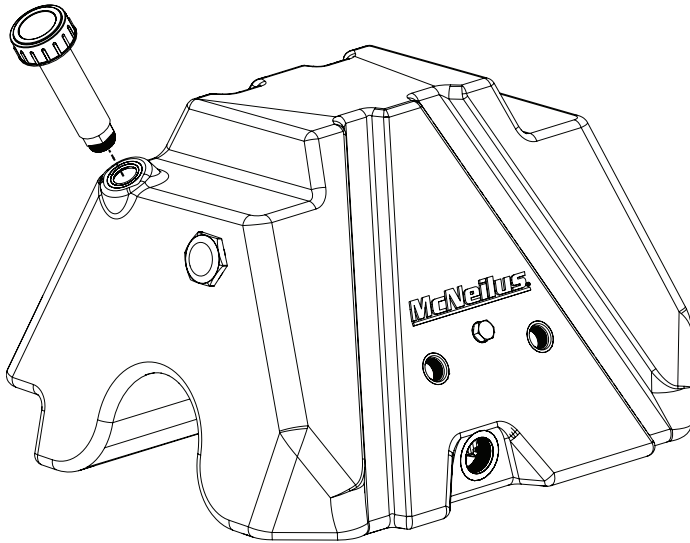
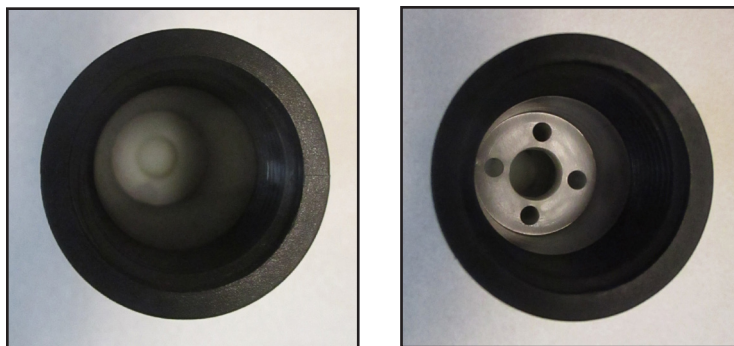

Figure 1

NOTE: The existing filler neck has one visible hole when looking at it from the top while the new filler neck (P/N 1570075) has five visible holes (see Figure 2). If you already have a filler neck with the five holes, and the filler neck is not damaged, there is no need to replace it. Skip to Step 8. If you have a filler neck that does not have five visible holes as shown (Figure 2, right side image), the filler neck must be replaced. Continue with the rest of this bulletin.



Existing Neck - 1 hole

New Replacement Neck
- 5 holes

Figure 2

3. If the existing breather cap is damaged, order a new cap (P/N 1320953) from McNeilus Truck and Manufacturing, Inc. Unscrew the cap from the existing filler neck (or use a new breather cap) and screw it onto the new filler neck (P/N 1570075) (Figure 3).

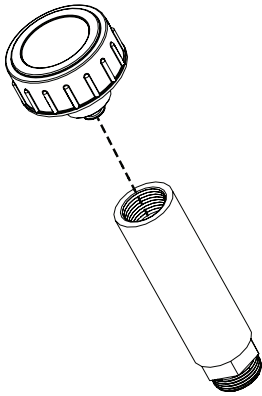

Figure 3

4. Ensure the o-ring is installed on the new filler neck at the bottom threads.
5. Screw the new filler neck onto the nylon reservoir and use the wrench to tighten the filler neck until snug. Then turn a 1/4 turn past snug.
6. If the oil level warning safety sign on the pedestal is damaged, not installed, or does not match the one provided with this bulletin, install the provided safety sign.
7. To install the sign,
 - a. Ensure the vehicle is at room temperature and is dry. The surface cannot be cold or wet or the sign will not adhere.
 - b. Use glass cleaner and a rag/towel to clean the surface of the pedestal.
 - c. Place and smooth the sign onto the pedestal in the location shown in Figure 4.

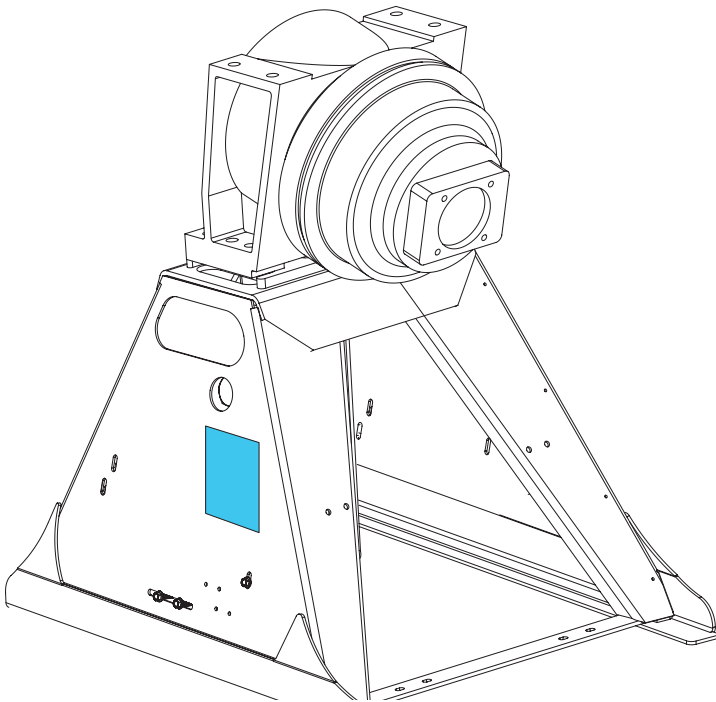

Figure 4

8. Remove your company's Lockout/Tagout procedure. If your company does not have a Lockout/Tagout procedure, follow OSHA 1910.147 and 1910.146 Confined Space as appropriate.

9. Check the oil level in the nylon reservoir sight glass (Figure 5, Item 1). The oil level should be visible in the middle of the sight glass.
 - For an accurate oil level reading, the Bridgemaster axle must be in the up position and the chute should be in the down position.
 - If the oil level is higher, place an oil collection container under reservoir and drain oil from bottom plugs until the level is visible in the middle of the sight glass. Dispose of oil according to proper regulations.
 - If the oil level is lower, refer to the operator's or service manuals for filling instructions.

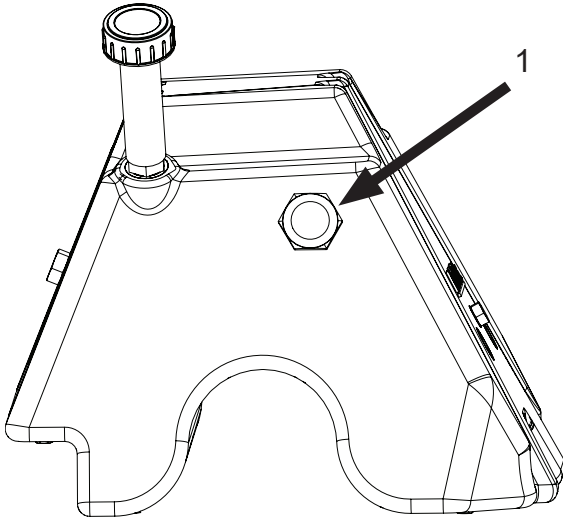

Figure 5

10. Reference the Mixer Mechanical Seminar and Training Manual (P/N 1468111) for information on checking the nitrogen level and the nitrogen cylinder accumulator and filling if necessary. The Mixer Mechanical Seminar and Training Manual (P/N 1468111) may be downloaded from www.streetsmartparts.com.
11. The procedure is complete.
12. The vehicle can be returned to service.

Continuous Improvement:

The change included in this document is part of the McNeilus Continuous Improvement Process.

McNeilus's quality policy is providing customer satisfaction through innovative products, dedicated service, and a constant focus on continuous improvement.



(888) 686-7278

www.streetsmartparts.com