

2009-2010 RX-8 - PASSENGER AIR BAG SAFETY RECALL 2018A

A. VEHICLE INSPECTION PROCEDURE

1. Verify that the vehicle is within the following ranges:

Zone B

Model	Note
2010 RX-8	Originally sold or ever registered in Arizona, Arkansas, Delaware, District of Columbia, Illinois, Indiana, Kansas, Kentucky, Maryland, Missouri, Nebraska, Nevada, New Jersey, New Mexico, North Carolina, Ohio, Oklahoma, Pennsylvania, Tennessee, Virginia, West Virginia

Zone C

Model	Note
2009 RX-8	Originally sold or ever registered in Alaska, Colorado, Connecticut, Idaho, Iowa, Maine, Massachusetts, Michigan, Minnesota, Montana, New Hampshire, New York, North Dakota, Oregon, Rhode Island, South Dakota, Utah, Vermont, Washington, Wisconsin, Wyoming

- If the vehicle is within the above ranges, proceed to Step2.
 - If the vehicle is not within the above ranges, return vehicle to the customer or inventory.
2. Perform a Warranty Vehicle Inquiry using your eMDCS System and inspect vehicle for Campaign Labels **Recall 2018A** attached to the vehicle's hood or bulkhead. Refer to eMDCS System - Warranty Vehicle Inquiry Results table below.

NOTE: Be sure to verify Recall number as the vehicle may have multiple Recall labels.

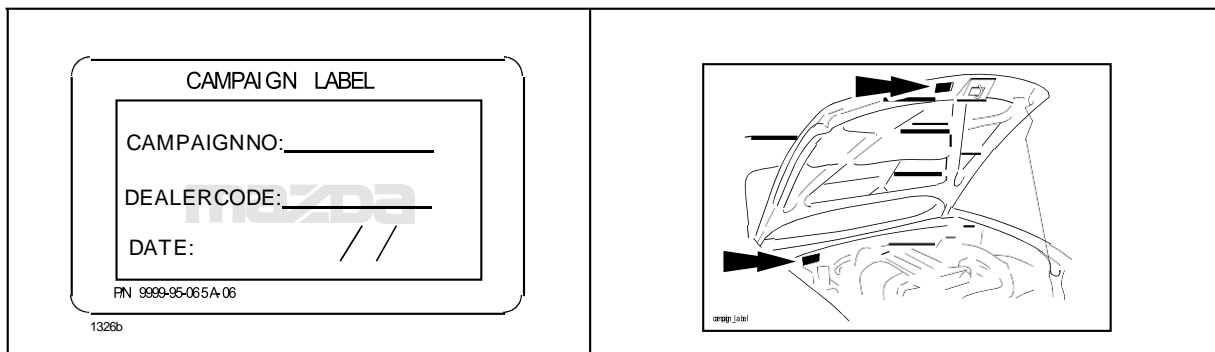

2009-2010 RX-8 - PASSENGER AIR BAG SAFETY RECALL 2018A

eMDCS System - Warranty Vehicle Inquiry Results:

If eMDCS displays:	Campaign Label is:	Action to perform:
RECALL 2018A OPEN	Present	Contact the Warranty Hotline at (877) 727-6626 option 3 to update vehicle history.
	Not present	Proceed to "B. REPAIR PROCEDURE".
RECALL 2018A CLOSED	Present	Return vehicle to inventory or customer.
	Not present	Proceed to "C. CAMPAIGN LABEL INSTALLATION".
RECALL 2018A is not displayed	Does not apply	Recall does not apply to this vehicle. Return vehicle to inventory or customer.

B. REPAIR PROCEDURE

Year / Model	Page No.
RX-8	3

2009-2010 RX-8 - PASSENGER AIR BAG SAFETY RECALL 2018A

RX-8:

Passenger-Side Air Bag Inflator Replacement Procedure:

Parts Information: The service parts are available in one box [Stopper plate (A), Inflator (B), and 4 Nuts (C)].

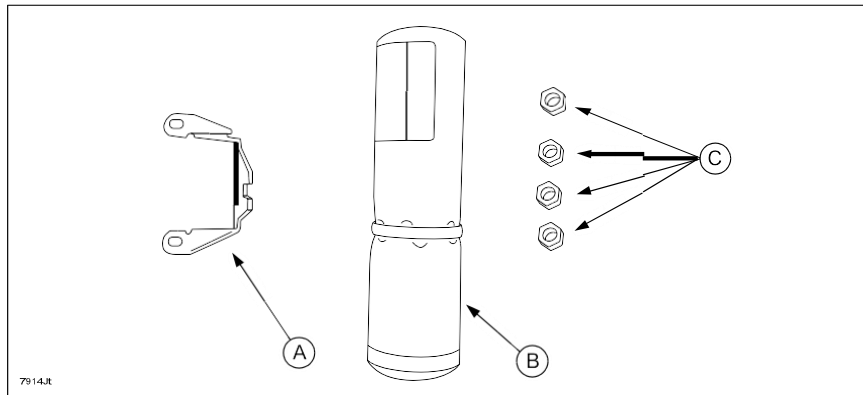

Outline:

1. Remove the inflator from the passenger-side air bag module (A), then replace it with a modified one (B) identified with a white stripe (C).

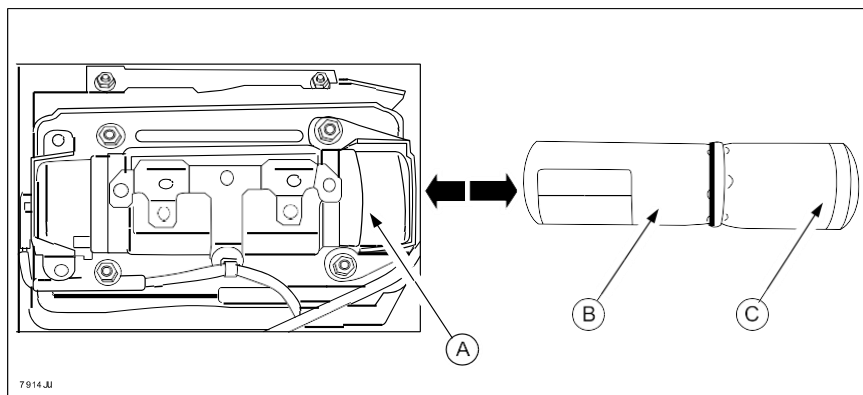

2. Pack and return the removed inflator as follows:

IMPORTANT: Be sure to follow the packing and shipping instructions provided in the carton and in the Air Bag Inflator Return Instructions available on MGSS.

CAUTION:

- Use the same carton which was used to deliver a new inflator. It is a specialized box that is internationally accepted for shipping an inflator.
- Pack the old inflator in the box exactly in the same manner as the new inflator was packed.

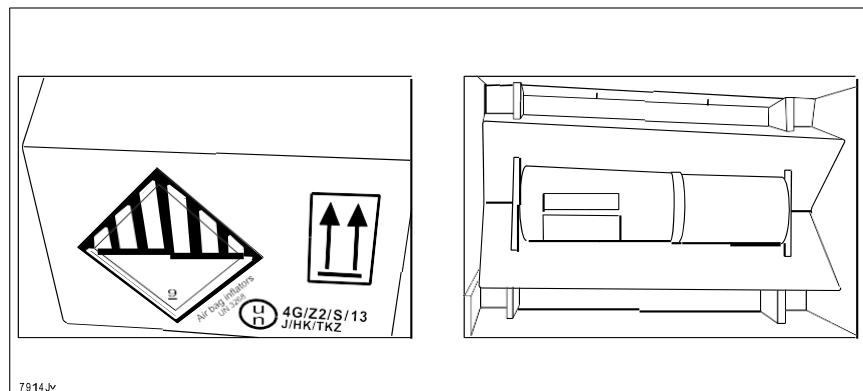

2009-2010 RX-8 - PASSENGER AIR BAG SAFETY RECALL 2018A

Air Bag Module Removal:

WARNING:

- Perform the replacement in a clean environment. Oil, grease, water, etc. on components may cause the air bag modules to fail to deploy in an accident, which may cause serious injury. Do not allow oil, grease, water, etc., on components.
 - Inserting a screwdriver, etc., into the connector of an air bag module may damage the connector and cause the air bag module to deploy improperly, which may cause serious injury. Do not insert any foreign objects into the connector.
 - Do not disassemble the vehicle, other than instructed here.
 - Do not make an attempt to directly supply electrical power to the module and the inflator.
 - Keep the module facing of the pad surface upwards at all times, except during replacement.
 - Do not use the module and new inflator if they were dropped on the ground.
 - Avoid module and inflator exposure to temperatures of 194 degrees F (90 degrees C) or more.
1. Turn the ignition switch to the LOCK position.
 2. Record the customer's preset radio stations.
 3. Disconnect the negative battery cable and wait for one (1) minute or more.
 4. Remove the glove compartment.
 - a. Pull the stay damper in the direction shown below.
 - b. Detach the glove compartment from the stay damper.

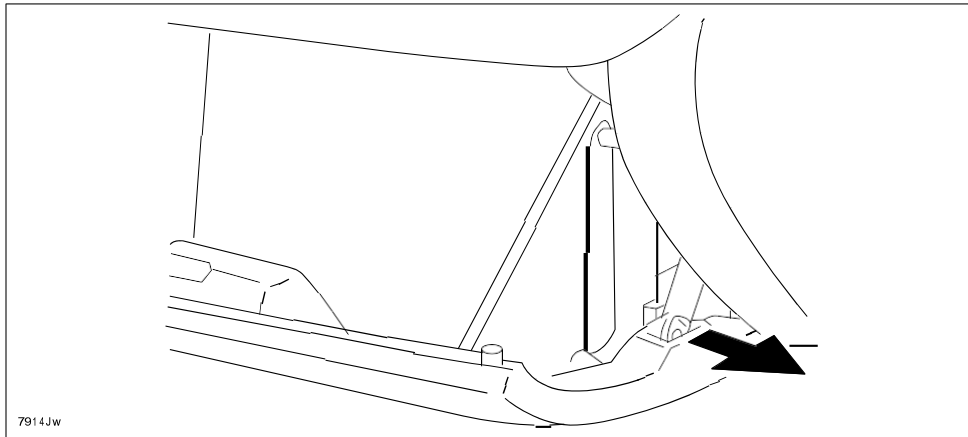

- c. Press the glove compartment stoppers inward.
- d. Lower the glove compartment downward.
- e. Detach the clips from the dashboard and remove the glove compartment.

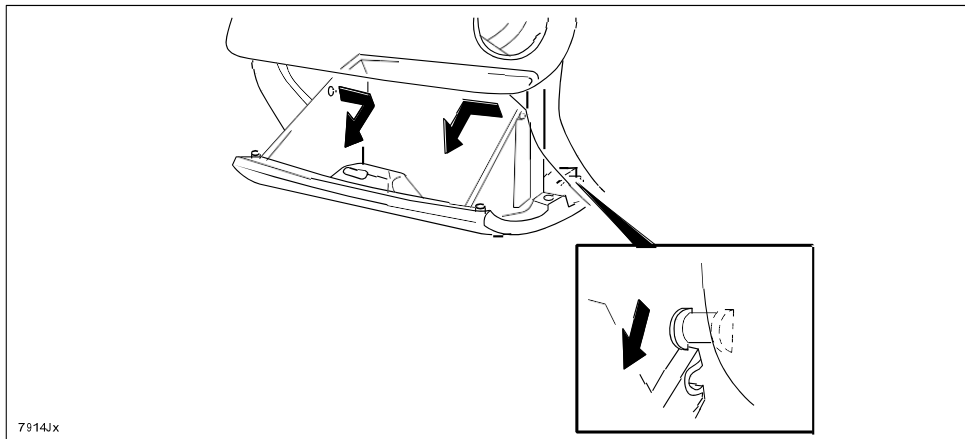

2009-2010 RX-8 - PASSENGER AIR BAG SAFETY RECALL 2018A

5. Remove the air bag module.
 - a. Remove the bolts (A).
 - b. Disconnect the connector (B).
 - c. Remove the air bag module (C).

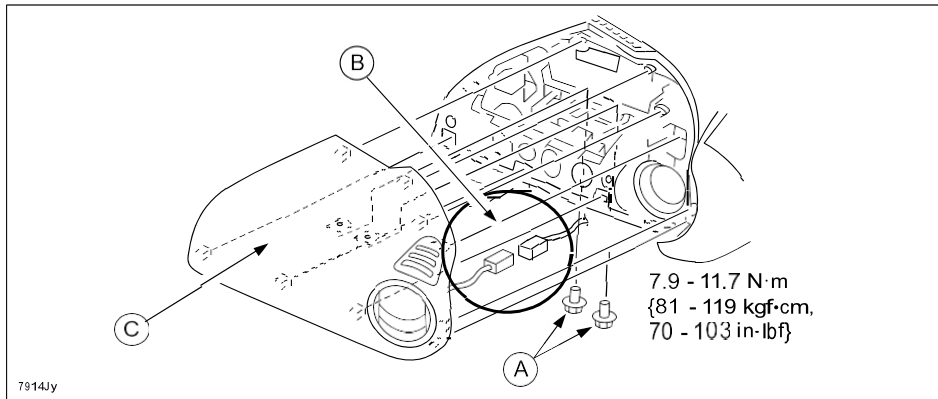

6. Lay a protective cloth on the work bench, then place the air bag module on it to avoid any damage or scratches to the surface.

Inflator Replacement:

CAUTION:

- Be careful when prying out the stopper plate. Otherwise, damage to the stopper plate could occur.
 - The stopper plate must be pried up before disconnecting the connector. Otherwise, the connector could be damaged if trying to disconnect it with the stopper plate engaged.
 - Use extreme care when disconnecting the connector. Otherwise, damage to the connector could occur.
1. Using a flathead screwdriver, pry out the connector stopper plate, then disconnect the connector (both sides).

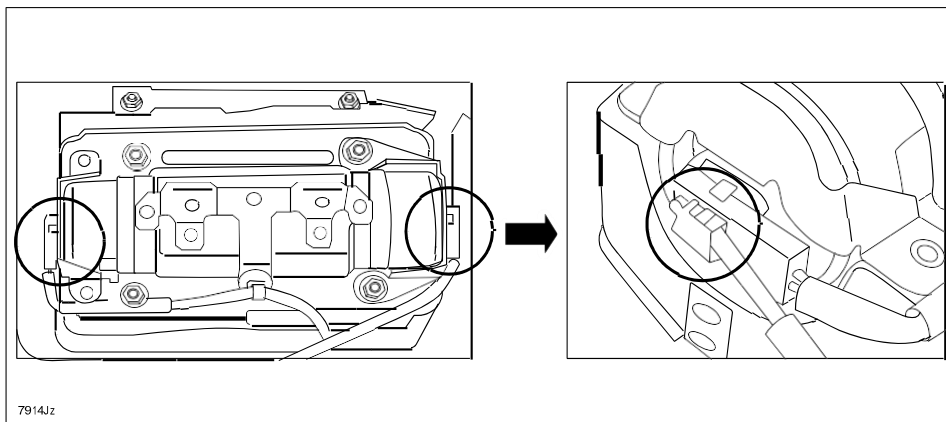

2. **NOTE:** If the passenger side inflator connector or pigtail is found to be damaged, a short cord is available for the RX-8 to replace the harness. Contact the Technical Hotline to order the short cord.
3. **NOTE:** If a stopper plate (A) is broken, replace the stopper plate with a new one, if applicable. Two types of stopper plates exist - an old type (GAY1-67-022) and a new type (GAY2-67-022). The exact switching date from the old type to the new type is unknown. Confirm the configuration of the stopper plate used on the vehicle in repair, and then use the one with the same configuration.

2009-2010 RX-8 - PASSENGER AIR BAG SAFETY RECALL 2018A

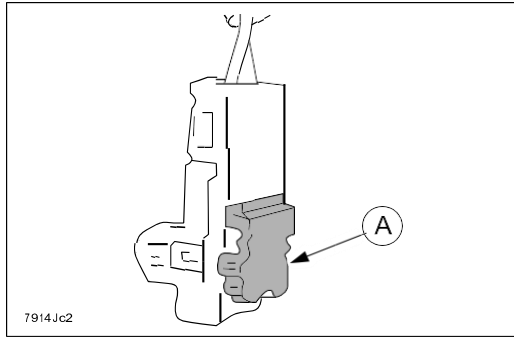

Old Type (GAY1-67-022)	New Type (GAY2-67-022)
<p>9418EC</p> <p>This diagram shows the old type of the inflator assembly. It features a top handle and a base with four mounting tabs. An arrow points to a specific feature on the top handle.</p>	<p>9418EJ</p> <p>This diagram shows the new type of the inflator assembly. It is similar to the old type but has a different top handle design with a circular opening.</p>

4. Loosen four (4) nuts until the upper surface of the nuts are aligned with the top edge of the screw thread.

2009-2010 RX-8 - PASSENGER AIR BAG SAFETY RECALL 2018A

5. For easier inflator removal, depress the four (4) nuts and make a gap between the inflator and air bag module.

NOTE: Do not depress excessively as the module body may detach.

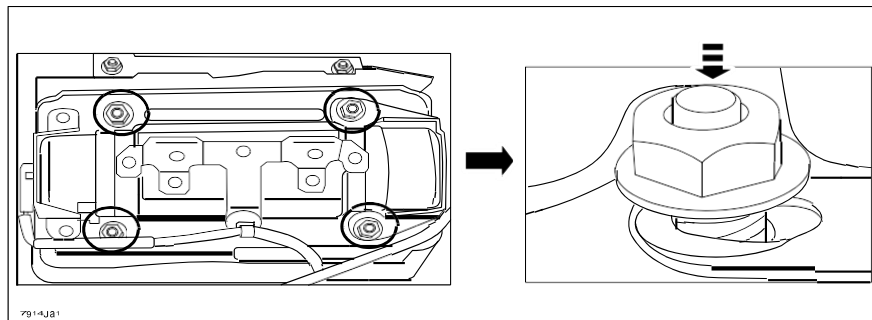

6. Remove the four (4) nuts, then remove the stopper plate from the air bag module.

NOTE: Discard all of the nuts and stopper plate.

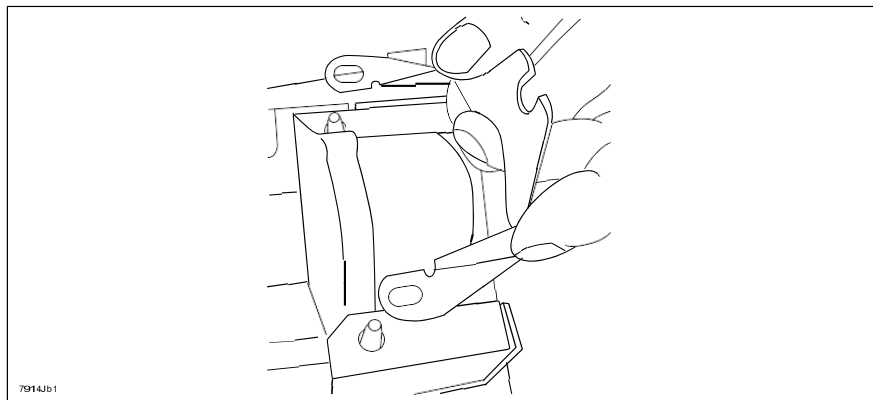

7. Push the inflator end with fingers, then remove it by sliding it in the direction shown below.

IMPORTANT: Return the removed inflator in the same carton in which the new part was received. Carefully follow the packing and shipping instructions included in the carton and make sure the part number of the replacement part is F1Z1-57-K80.

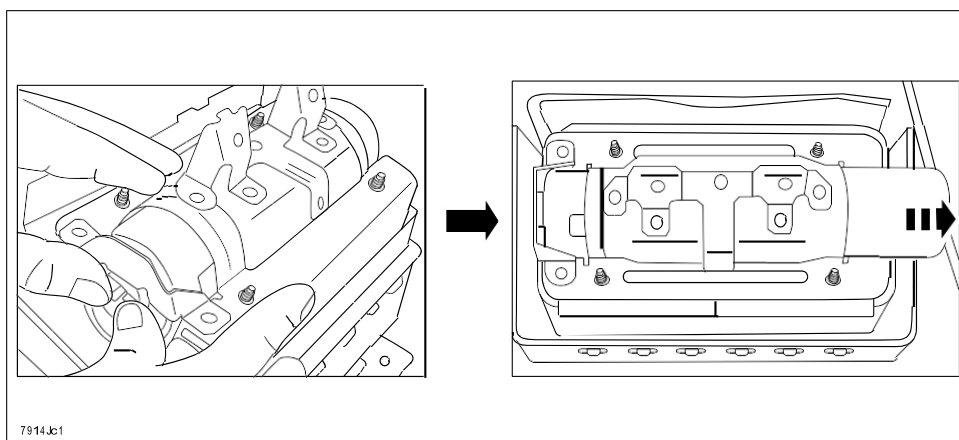

2009-2010 RX-8 - PASSENGER AIR BAG SAFETY RECALL 2018A

8. Insert the modified inflator from the opposite side of where the white identification tape (A) is located.

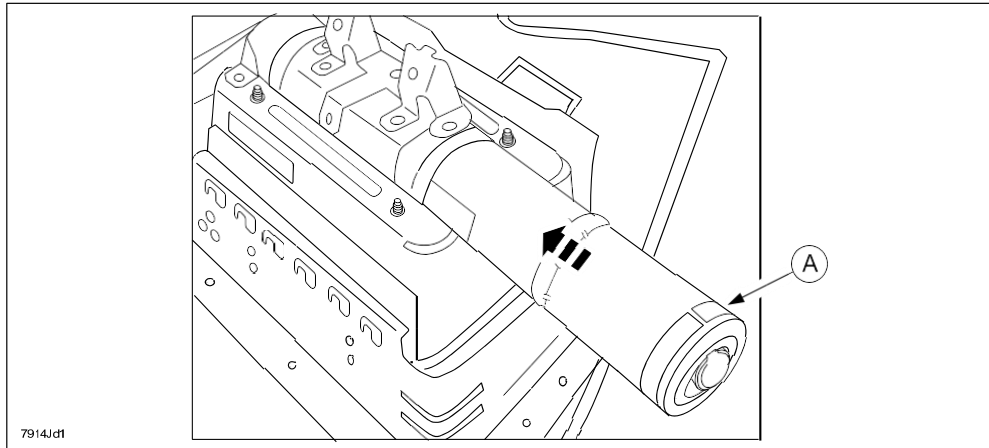

9. Insert the inflator up to the position where it touches the stopper (B), aligning the D-shape end of the inflator with the stopper opening (A).

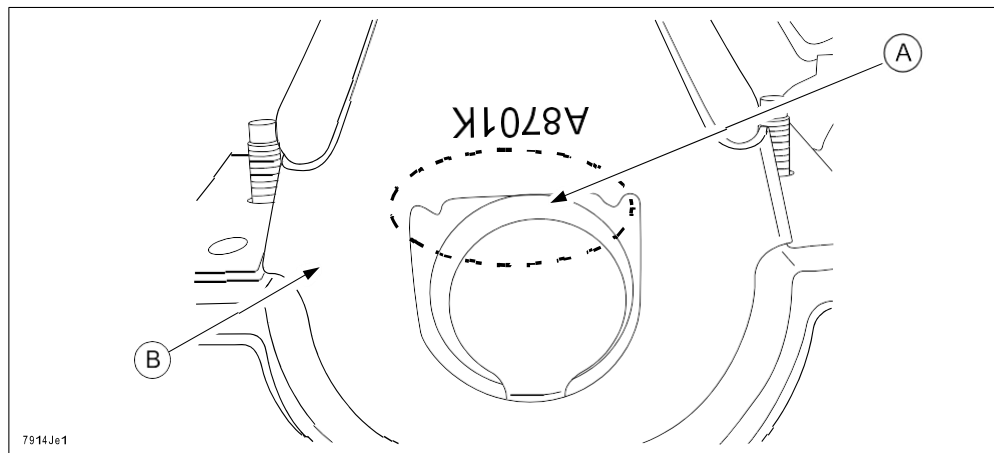

10. Set the new stopper plate (A) by gently pushing until it touches with the inflator side (B).

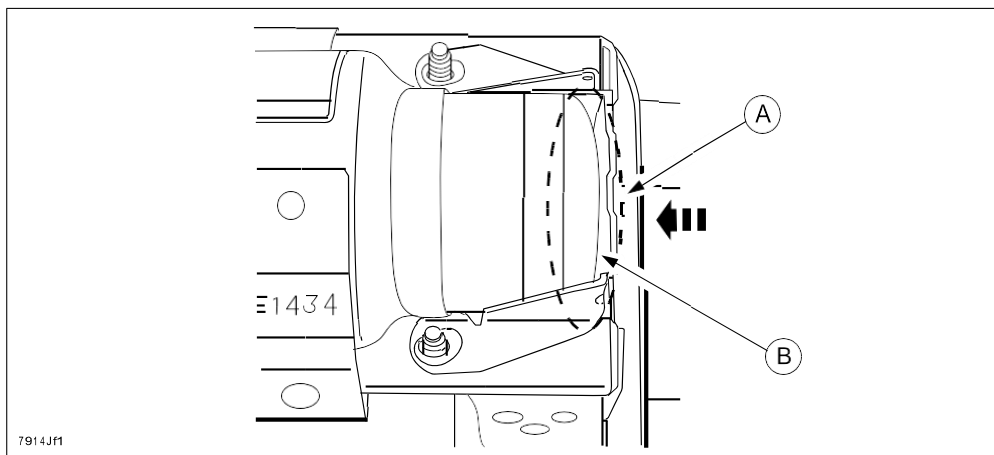

11. Keeping the position above, hand tighten the four (4) new nuts.

2009-2010 RX-8 - PASSENGER AIR BAG SAFETY RECALL 2018A

12. Tighten the four (4) new nuts to the specified torque in the order shown below (1, 2, 3, 4).
Tightening Torque: 35 +/- 1.8 in-lbf. {39.8 +/- 2.0 kgf-cm, 3.9 +/- 0.4 Nm}

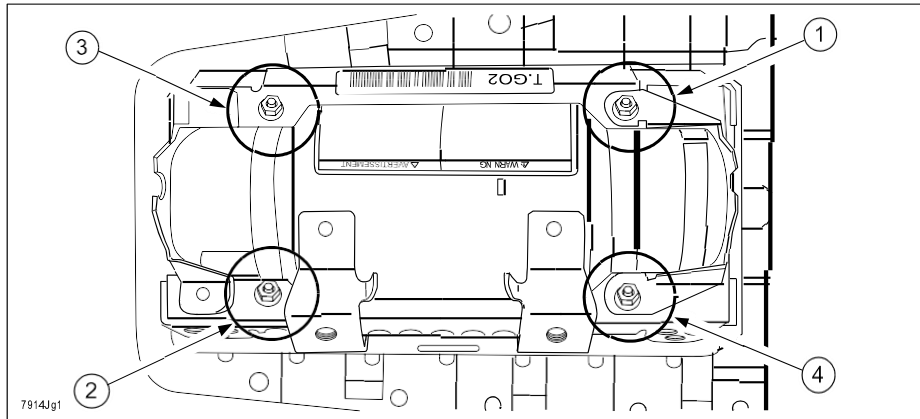

13. Remove the seal (A) from the end of the inflator on both sides.

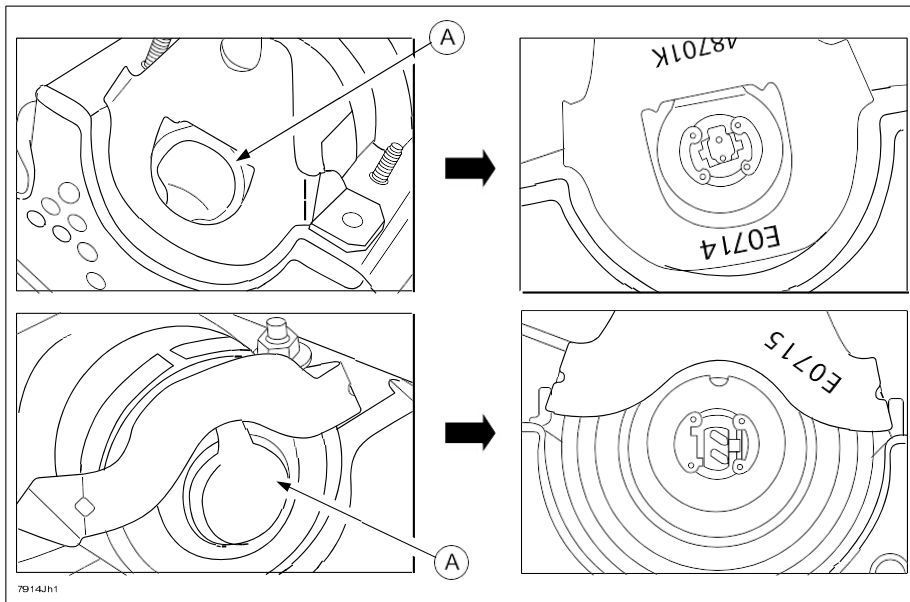

14. Re-connect the connectors to the air bag module.
15. Securely lock the connectors by depressing the stoppers on the back of the connector (A).

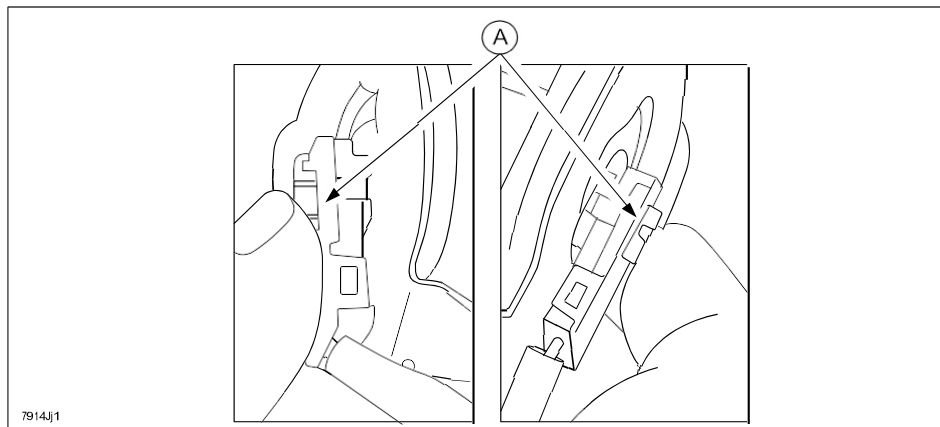

Air Bag Module Reinstallation:

1. Re-connect the connector (A), then install the air bag module (B) and the bolts (C).
Tightening Torque: 70 - 103 in-lbf. {81 - 119 kgf-cm, 7.9 - 11.7 Nm}

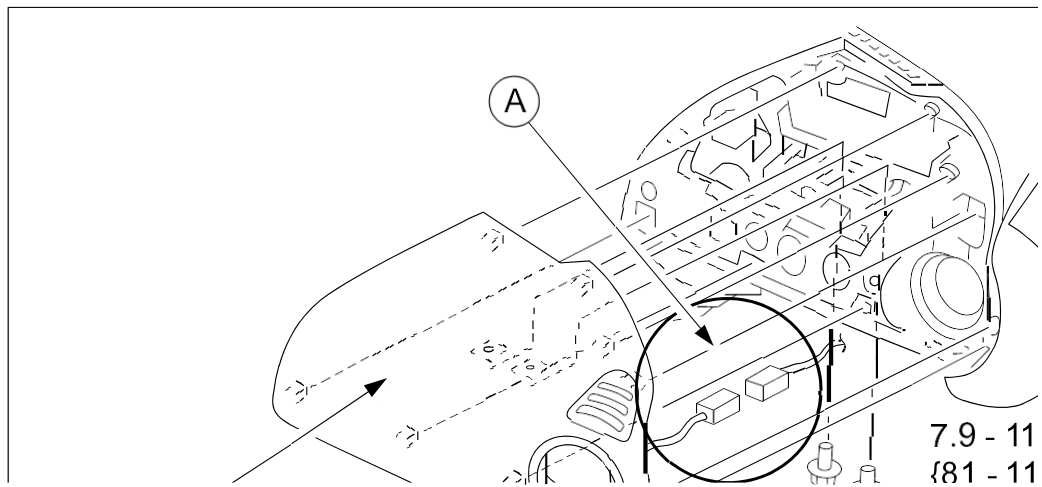

2. Reinstall the glove box.
3. Reconnect the negative battery cable.
4. Turn the ignition switch to the ON position.
5. Verify that the air bag system warning light illuminates for approx. 6 sec., then goes out.
NOTE: If the air bag system warning light does not operate in the manner described above, there is a malfunction in the system. Inspect the system following the on-board diagnostic system procedure according to MS3 online or the Workshop Manual (section 08 Restraints).
6. Re-enter the customer's preset radio stations.
7. Proceed to "C. CAMPAIGN LABEL INSTALLATION".

C. CAMPAIGN LABEL INSTALLATION

1. Fill out a blue "Campaign Label" (9999-95-065A-06) with Campaign No: "0617A", your dealer code, today's date.

1326b

CAMPAIGN LABEL	
CAMPAIGN NO:	_____
DEALER CODE:	_____
DATE:	/ /

P/N 9999-95-065A-06

2. Affix it to the hood or bulkhead as shown:

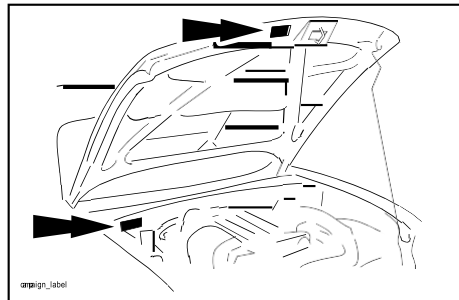

3. Return the vehicle to customer.