



July 24, 2018

Name
Street
City, State Zip

IMPORTANT SAFETY RECALL NOTICE: 18E047

IMPORTANT SAFETY RECALL

This notice applies to aerial device(s):

Dear KME Customer:

This notice is sent to you in accordance with the requirements of the National Traffic and Motor Vehicle Safety Act.

Why is a recall being conducted?

KME has decided that a defect which relates to motor vehicle safety exists in the tip mounted lifting devices supplied with aerial ladder assemblies.

The supplied lifting devices (95347115 and 95347118) do not meet the specified load rating or safety factor. If the specified load is attached to the lifting device, the device may deform and may lead to injury to those nearby.

What are we doing about the problem?

At no cost, KME will replace the tip lifting device. As the vehicle manufacturer, you may elect for KME to implement the remedy directly with the vehicle owner. If you choose this option, you will need to provide KME with the owner's contact information. You may also elect to remedy the vehicles on your own. If you chose this option, KME will provide you with the replacement tip lifting devices.

What should you do?

If you receive this notification, please contact your KME Dealer or KME Customer Service at (570) 669-5230 to schedule an appointment to have your vehicle(s) remedied.

INCLUDED WITH THIS LETTER IS AN OWNER RESPONSE CARD THAT MUST BE FILLED OUT AND RETURNED TO KME IN ORDER TO BE REIMBURSED. Please have your Truck VIN or GSO available. After the repair has been completed, please fill in the appropriate information on the enclosed Owner Response Postcard, sign it, and return it to:

Mail: KME, One Industrial Complex, Nesquehoning, PA 18240

E-mail: bpolgreaan@kmeffire.com

Fax: (570) 645-9705

What if you no longer own this vehicle?

If you are not the current owner of the vehicle, please indicate this on the Owner Response Postcard and return the card to us.

Federal law requires any lessor who receives a notification of a safety related defect or noncompliance pertaining to any leased motor vehicle shall send the notice to the lessee within 10 days. If you are no longer the owner of this vehicle, please provide us with any contact information so we may contact the new owner.

If you have already paid to have your vehicle repaired for this condition, you may be eligible for reimbursement of the charges you paid for the repair or replacement of components. To learn more about what you need to do to obtain reimbursement, contact our customer service department.

If after having attempted to take advantage of this recall you believe you have not been able to have your vehicle remedied without charge and within a reasonable amount of time, you may submit a complaint to the Administrator, National Highway Traffic Safety Administration, 1200 New Jersey Ave., S.E., Washington, D.C., 20590; or call the toll-free Vehicle Safety Hotline at 1-888-327-4236 (TTY: 1-800-424-9153); or go to <http://www.safercar.gov>.

We apologize for any inconvenience this safety recall may cause, but your safety is our first concern.

Sincerely,

KME, Inc.

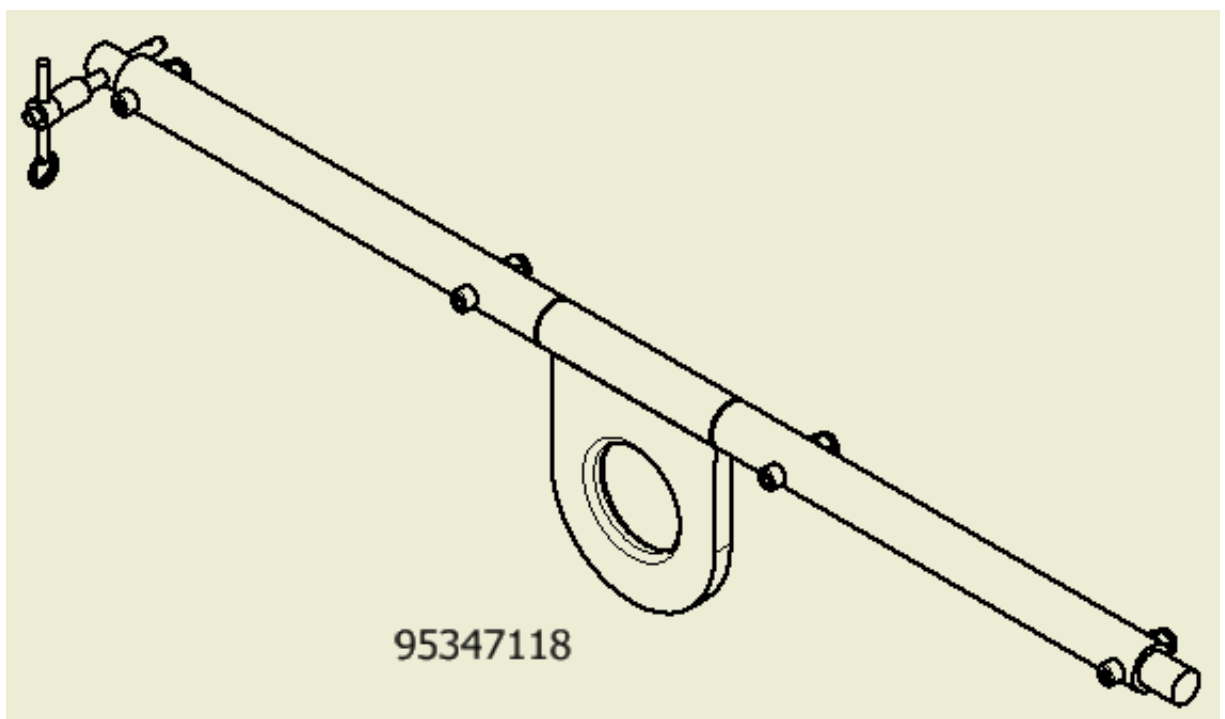
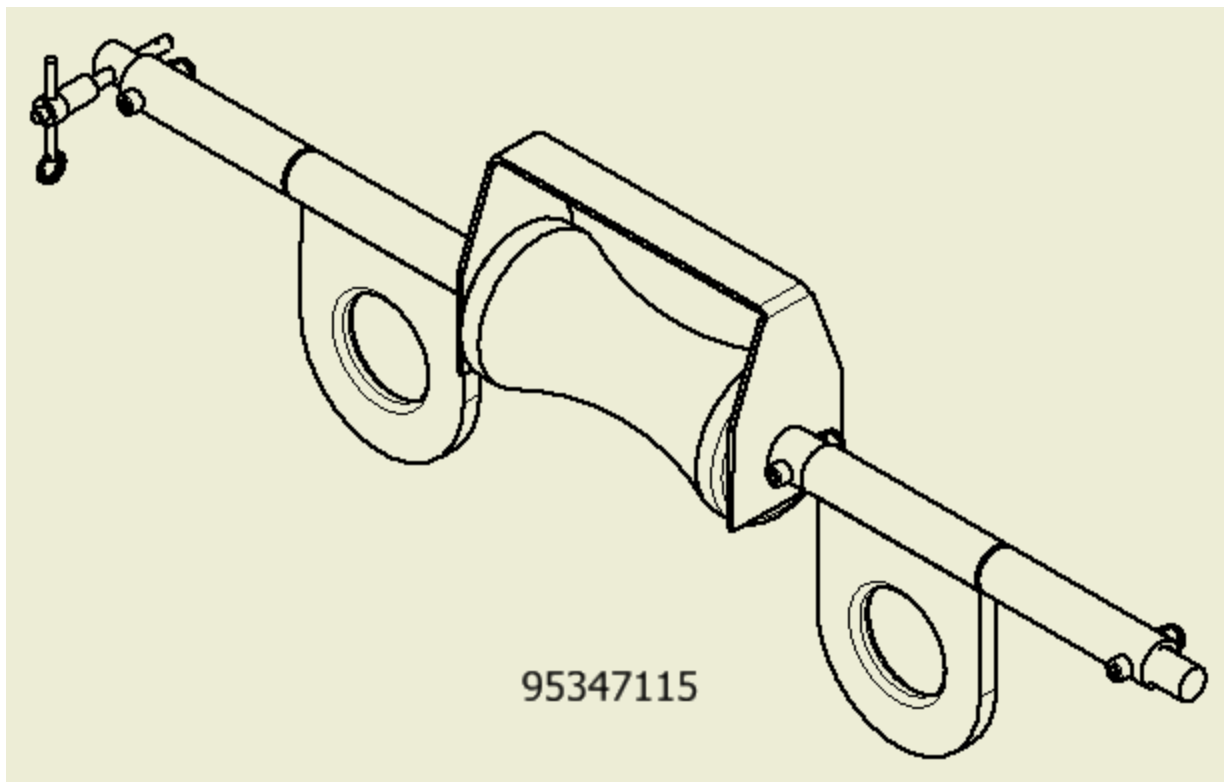

From: _____
(Customer name)

To: KME Fire Apparatus
One Industrial Complex
Nesquehoning, PA 18240

RE: NHSTA Recall No. 18E047

Date: _____
KME GSO(s) or VIN(s) _____

-
- This vehicle was inspected and repaired according to instructions.
 - This vehicle was inspected and determined to not need repair.
 - This vehicle was sold to: _____ Name, Address, City, State/ZIP
 - This vehicle was stolen.
 - This vehicle was destroyed.

Owner's (or Former Owner's) Signature

IMPORTANT SAFETY RECALL INFORMATION



Issued in Accordance
With Federal Law



Please return this form by fax (570) 645-9705, by E-mail to bpolgrian@kmeffire.com, or by phone (570) 669-5230.