

IMPORTANT SAFETY RECALL NOTICE

Re: FiTech Recall of Max efi500 Carburetor Fuel Injection Kits Sold by Summit Racing Equipment

This notice is being sent to you in accordance with the requirements of the National Traffic and Motor Vehicle Safety Act.

Fuel Injection Technology, Inc. (“FiTech”), manufacturer of the **Max efi500** kit sold by Summit Racing Equipment, has decided that a defect relating to highway traffic safety exists in replacement equipment: **Max efi500** kits (Summit Part No. SUM-240500). The recalled **Max efi500** kits were distributed exclusively by Summit Racing Equipment and installed by performance shops and DIY hobbyists as aftermarket replacements on non-pollution-controlled vehicles of various makes including popular hot rods and muscle cars. *Summit Racing Equipments’ customer service records indicate you may have purchased a recalled Max efi500 kit. Please carefully review the following product identification information and instructions for obtaining a free replacement component kit to amend the recalled Max efi500.*

Identifying The Recalled Max efi500 Carburetor Fuel Injection Kits

FiTech’s **Max efi500** kits were sold by Summit Racing Equipment between approximately 9.1.17 and 4.30.18 as Summit Part No. SUM-240500. The kit consists of a throttle body, fuel rail, injectors, O-rings and related hardware and attachment pieces. The recalled parts can be further identified by the styled “*Max-efi500*” and “*Summit Racing Equipment*” laser etching visible on the top and outside surfaces of the fuel rails, similar to the illustration:

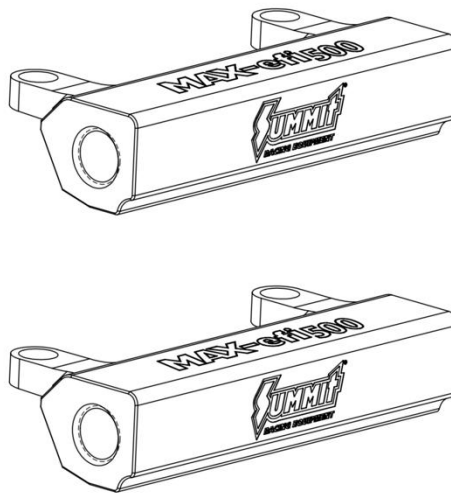

What Is The Defect/Reason For This Recall?

Incompatible machining tolerances between fuel rail and injector unit may compromise or accelerate deterioration of injector O-ring seal. Potential for fuel leak at injector O-ring creates increased risk of improper fuel metering, fire, or loss of engine power possibly resulting in a vehicle crash with or without prior warning.

! WARNING

To reduce risk of fire or accident, including loss of engine power possibly resulting in vehicle crash, immediately inspect your vehicle to determine if you have a recalled **Max efi500** kit. Injector O-ring failure may or may not be preceded by inconsistent fuel metering, fuel odor from hood area, leaks or visible fuel signatures on or around fuel rails and throttle body. *Do Not Use Vehicle Until You Have Replaced Fuel Rails Per This Recall.*

What Will FiTech Do?

Without net charge to customers, FiTech will supply customers with replacement fuel rail kits. FiTech anticipates that replacements will be available beginning on or about May 15, 2018.

What You Should Do?

Inspect your vehicle and any EFI inventory received from Summit Racing Equipment to determine if your vehicle uses or your shop has any of the recalled **Max efi500** kits (Summit Part No. SUM-240500). *Directly* contact FiTech at 888/504-4084 to receive a recall Return Merchandise Authorization (RMA) and to arrange shipping of your replacement kit(s) and return of recalled components. The replacement kit includes fuel rails, O-rings, banjo bolts, washers, lubricant, Allen wrench, complete installation instructions and a prepaid shipping label for return of the original parts you replaced. Replacement fuel rails supplied under this recall are distinguished by an asterisk (*) etched into the fuel rail, similar to the illustration below. Other FiTech EFI kits, components, Summit Racing Equipment and OEM parts **are not affected by this recall.**

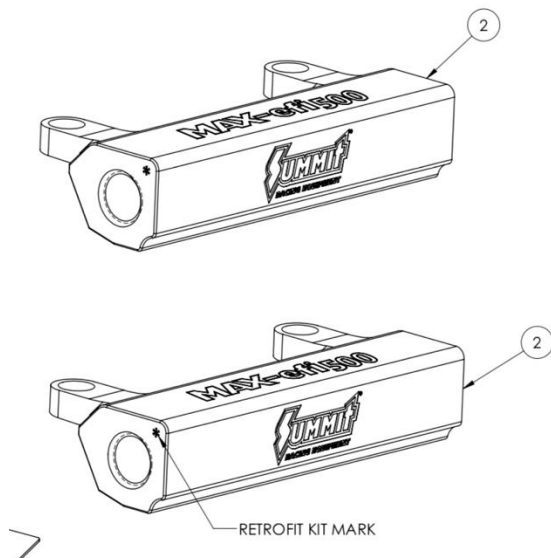

What If You Need A Service Center To Perform This Recall?

Customers who do not feel comfortable replacing the **Max efi500** kits or fuel rails themselves and would prefer to have a FiTech designated service center perform the work will be offered reimbursement for up to 1.0 hours labor at prevailing rates of the designated service center. *Directly* contact FiTech customer service at 888/504-4084 to arrange replacement at a designated service center.

What If You Have Already Performed This Recall?

Customers who have replaced or repaired suspect **Max efi500** kits or fuel rails *prior to this recall* will be offered reimbursement for the cost of the upgrade/replacement parts and up to 1.0 hours labor at prevailing rates if work was performed by a service center. Contact FiTech customer service @ 951/340-2624 for information and reimbursement for previously completed repairs. Please have proof of purchase and repair available.

What If You No Longer Own The Vehicle With The Recalled Max efi500 Kits/Are Unable to Obtain a Replacement for the Recalled Max efi500 kit?

If you no longer own the vehicle you believe has or may have a recalled **Max efi500** kit please forward this information to the new owner and also provide FiTech with the new owner's contact information (see contact information above). If you are a lessor of a vehicle with a recalled **Max efi500** kit you should send a copy of this notice to the lessee within 10 days of receiving this notice as required by 49 CFR Sec. 577.7(a)(2)(iv). If after a reasonable time you still are unable to obtain a repair of your recalled **Max efi500** kit you may file a complaint with: *The Administrator, National Highway Safety Administration, 1200 New Jersey Ave., SE., Washington, DC 20590; or call the toll-free Vehicle Safety Hotline at 1-888-327-4236 (TTY: 1-800-424-9153); or go to <http://www.safercar.gov>.*

If you have further technical questions about your replacement fuel rails you may contact FiTech technical assistance at 951/340-2624 or PSN@fiTechEFI.com. FiTech and Summit Racing Equipment apologize for any inconvenience this voluntary recall may cause; however, our overriding concerns are your safety and satisfaction with the products we sell.