

POSTED ON ISIS

DEC 13 2017

MAILED

DEC 14 2017

Compliance Dept

Compliance Dept.

# **SERVICE PROCEDURE**

17512

December, 2017

**SUBJECT: SAFETY RECALL  
SEATBELT ROD BOLT on certain CE and RE  
school bus models built 17 December 2015 thru 22  
January 2016 with IMMI 39 inch BTI 3-point seats.**

## **DEFECT DESCRIPTION**

Certain IMMI school bus seat assemblies equipped with 3-point lap and shoulder belts do not satisfy the requirements of FMVSS 210. There is a potential that when under a sufficient load, the buckle mount rod may fracture. A seat belt assembly that does not conform to all the requirements of FMVSS 210 may not protect the occupant sufficiently in the event of a collision resulting in possible injury.

## **MODELS INVOLVED**

This Safety Recall involves certain CE and RE school models built 17 December 2015 thru 22 January 2016 with IMMI 39-inch BTI 3-point seats.

## **ELIGIBILITY**

This procedure applies ONLY to vehicles marked in the International® Service Portal™ with Safety Recall 17512. Also complete any other open campaigns listed on the Service Portal at this time.

## **PARTS INFORMATION**

**NOTE: This campaign affects only nine dealer locations. These dealers have been contacted and the parts / kits associated with this campaign will be shipped to them at no cost with identified VIN marked on each kit**

## **SERVICE PROCEDURE**

**WARNING! To prevent property damage, personal injury, and / or death, park vehicle on hard flat surface, turn the engine off, set the parking brake and install wheel chocks to prevent the vehicle from moving in either direction.**

**WARNING! To prevent personal injury and / or death, always wear safe eye protection when performing vehicle maintenance.**

**WARNING! To prevent property damage, personal injury, and / or death, keep flames or sparks away from vehicle and do not smoke while servicing the vehicle's batteries. Batteries expel explosive gases.**

1. Park vehicle on flat surface.
2. Shift transmission to Park or Neutral and set parking brake.
3. Turn vehicle ignition to Key OFF position.
4. Install wheel chocks.

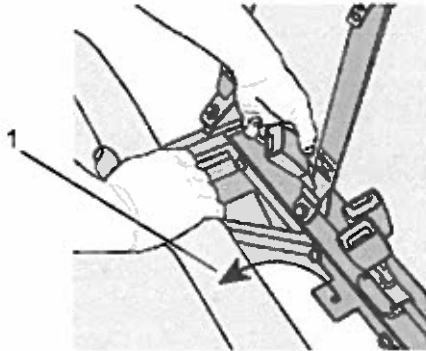

0000420518

**Figure 1. Seat Cushion Unlatching**

1. Seat cushion
2. Unlatch seat cushion (Figure 1, Item 1) and pivot cushion up and forward.

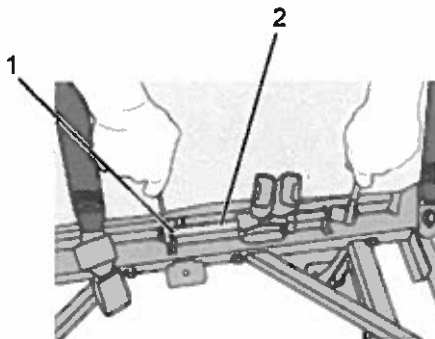

0000429519

**Figure 2. Slider Rod Loosening**

1. Center nut
  2. Slider rod
- NOTE: It may be necessary to grasp the rod with vise grips if the nut furthest from the center of the seat begins to loosen first.**
6. Loosen and remove nut (Figure 2, Item 1) on end of slider rod (Figure 2, Item 2) closest to the center of seat.

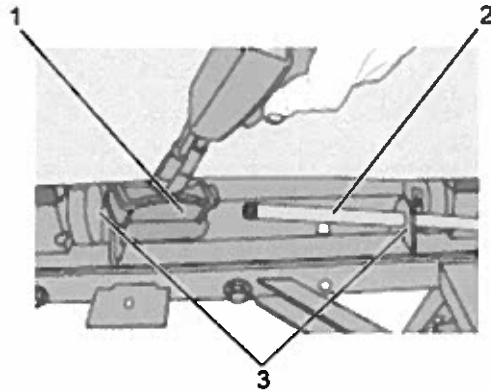

0C00429517

**Figure 3. Slide Rod Removal**

1. Buckle slider
2. Slider rod
3. Bracket

7. Slide rod (Figure 3, Item 2) to left (as sitting in seat) enough for end near center of seat to clear bracket (Figure 3, Item 3).
8. Tilt rod enough to clear bracket near center of seat.

**Note: Do not let the buckles fall when removing the slide rod and buckle assembly.**

9. Holding buckles, slide rod out and remove buckle slider assembly (Figure 3, Item 1).

**NOTE: Rod and nuts are to be returned to IMMI.**

10. Remove rod from bracket near end of seat.
11. Insert new rod into bracket near end of seat.
12. With new rod tilted enough to clear bracket near center of seat, position buckle slider assembly and slide rod into position.
13. Slide rod to right (as sitting in seat) so that end near center of seat can extend past bracket.
14. Install nuts, using a torque wrench, tighten to 26 lb-ft (35 N•m)
15. Verify buckle slider is properly installed onto rod and free to slide on buckle rod.
16. Pivot seat cushion rear down and latch into position.

17. Repeat Steps 5 thru 16 for each additional seat that requires belt buckle rod replacement.
18. Remove wheel chocks.

**END OF SERVICE PROCEDURE**

**LABOR INFORMATION**

<b>Operation Number</b>	<b>Description</b>	<b>Time</b>
A40-17512-1	Replace seat belt buckle rod; first seat	0.3 hrs
A40-17512-2	Replace each additional seat buckle rod	0.1 hrs

**SPECIAL HANDLING INFORMATION**

In "Other Charges" section, enter a handling fee of \$30.00

**PARTS RETURN INFORMATION**

Return rods to:

IMMI

18881 IMMI Way

Westfield, In. 46074

Attention: Scott Hoffman

RMA #703284

UPS Account #444130

## CAMPAIGN IDENTIFICATION LABEL

Each vehicle corrected in accordance with this campaign must be marked with a CTS-1075 Campaign Identification Label.

Complete the label and attach on a clean surface next to the vehicle identification number (VIN) plate.

DO NOT REMOVE	
INTERNATIONAL	
Campaign No.	
VIN	Eng.#
COMPLETED	
Service Location Code #	
DO NOT REMOVE	

## ADMINISTRATIVE / DEALER RESPONSIBILITIES

### WARRANTY CLAIMS

Warranty claim expense is to be charged to Warranty. Claims are to be submitted in the normal manner, making reference to Safety Recall 17512.

Section 7 of the Warranty Policy and Procedures Manual contains further information related to the submission and processing of AFC / Recall claims.

As with all claim submissions, items acquired locally must be submitted in the "Other Charges" tab. The cost of any bulk items (such as a bag of cable tie straps, roll of wire, barrel of oil, or tube of silicone) should be prorated for the cost of the individual pieces / amount used during each repair.

GROUP	NOUN	C	WARR	TP	PAD

GROUP — Enter number ←

NOUN — Leave blank ←

C (CAUSE) — Enter either 1, 2, 3. (See below)

1. Inspected (No repair required).
2. Inspected and repaired.
3. Defective part from parts stock.

WARRANTY — (Warranty Code) Enter 40. ←

TYPE PART — Enter P for type part causing failure. ←

PAD — Enter 100 ←

0000047910

### VEHICLE RECALL 17512

© 2017 Navistar, Inc. All rights reserved. All marks are trademarks of their respective owners.

## **UNITED STATES AND POSSESSIONS**

The National Traffic and Motor Vehicle Safety Act, as amended, provides that each vehicle that is subject to a vehicle recall campaign must be adequately repaired within a reasonable time after the owner has tendered it for repair. A failure to adequately repair within 60 days after a tender of a vehicle is prima facie evidence of failure to repair within a reasonable time. If the condition is not adequately repaired within 60 days, the owner may be entitled to replacement with an identical or reasonable equivalent vehicle at no charge, or to a refund of the purchase price less a reasonable allowance for depreciation.

Dealers must correct all vehicles subject to this campaign at no charge to the owner, regardless of mileage, age of vehicle, or ownership, from this time forward.

Dealers should proceed immediately to make necessary correction to units in inventory. All inventory vehicles subject to this recall campaign must be corrected prior to sale, transfer or delivery. If vehicles have been sold or transferred and you are in receipt of Customer Notification Letters and Authorization for Recall Service cards for those vehicles, the transfer location or customer must be notified immediately from your dealer location.

Dealers must make every effort to promptly schedule an appointment with each owner to repair his or her vehicle as soon as possible. However, consistent with the customer notification, dealers are expected to complete the repairs on the mutually agreed upon service date.

Dealers involved in the recall process will be furnished a listing of owner names and addresses to enable them to follow up with owners and have the vehicles corrected. Use of this listing must be limited to this campaign because the list may contain information obtained from state motor vehicle registration records, and the use of such motor vehicle registration data for purposes other than this campaign is a violation of law in several states.

## **CANADA**

Dealers must correct all vehicles subject to this campaign at no charge to the owner, regardless of mileage, age of vehicle, or ownership, from this time forward.

Dealers should proceed immediately to make necessary correction to units in inventory. All inventory vehicles subject to this recall campaign must be corrected prior to sale, transfer or delivery. If vehicles have been sold or transferred and you are in receipt of Customer Notification Letters and Authorization for Recall Service cards for those vehicles, the transfer location or customer must be notified immediately from your dealer location.

Dealers must make every effort to promptly schedule an appointment with each owner to repair his or her vehicle as soon as possible. However, consistent with the customer notification, dealers are expected to complete the repairs on the mutually agreed upon service date.

Dealers involved in the recall process will be furnished a listing of owner names and addresses to enable them to follow up with owners and have the vehicles corrected. Use of this listing must be limited to this campaign because the list may contain information obtained from state motor vehicle registration records, and the use of such motor vehicle registration data for purposes other than this campaign is a violation of law in several states.

#### **EXPORT**

Export Distributors should proceed immediately to make necessary correction to units in inventory. All inventory vehicles subject to this recall campaign must be corrected prior to sale, transfer or delivery. If vehicles have been sold or transferred and you are in receipt of Customer Notification Letters and Authorization for Recall Service cards for those vehicles, the transfer location or customer must be notified immediately from your distributor location.

Export Distributors are to submit warranty claims in the usual manner making reference to this recall number.

Export Distributors are expected to provide full cooperation and follow-up with respect to this important subject matter. If you have any questions or need further assistance, please contact the Regional Service Manager at your regional office.

**NAVISTAR, INC.**