



# Safety Recall

## Code: 20Y6

<b>Subject</b>	<b>Suction Pump</b>
<b>Release Date</b>	October 13, 2016
<b>Affected Vehicles</b>	<b>U.S.A. &amp; CANADA: 2015-2016 MY Volkswagen Golf, GTI &amp; Golf SportWagen</b> <i>Check Campaigns/Actions screen in Elsa on the day of repair to verify that a VIN qualifies for repair under this action. Elsa is the <u>only</u> valid campaign inquiry &amp; verification source.</i> <ul style="list-style-type: none"><li>✓ Campaign status must show "open."</li><li>✓ If Elsa shows other open action(s), inform your customer so that the work can also be completed at the same time the vehicle is in the workshop for this campaign.</li></ul>
<b>Problem Description</b>	The suction pump inside the fuel tank designed to purge fuel from the evaporative emissions (EVAP) system may have been damaged during assembly. This could cause fuel to flow directly into the EVAP system which could, over time, accumulate and cause a leak through the charcoal canister filter element. Leaking fuel, in the presence of an ignition source, may result in a fire.
<b>Corrective Action</b>	Replace the suction pump inside the fuel tank.
<b>Precautions</b>	If a fuel smell is detected in the vehicle, customers should immediately contact an authorized Volkswagen dealer to have the vehicle inspected.  Additionally, customers may experience refueling issues (early stopping of the fuel nozzle and fuel spillback) when fuel accumulates in the EVAP system. If this happens, customers should immediately contact an authorized Volkswagen dealer to have the vehicle inspected.
<b>Parts Information</b>	Parts will be allocated prior to owner notification. <ul style="list-style-type: none"><li>• Targeted allocation will be used for 5Q0201029 (suction pump).</li><li>• Upper order limits will be used for 1J0919133B (seal). If your dealership is at the weekly Upper Order Limit, submit requests for additional parts via email to <a href="mailto:vwoupperorderlimits@vw.com">vwoupperorderlimits@vw.com</a>.</li></ul>
<b>Code Visibility</b>	On or about October 13, 2016, affected vehicles will be listed on the Inventory Vehicle Open Campaign Action report under My Dealership Reports (found on <a href="http://www.vw.com">www.vw.com</a> & OMD Web). A list will not be posted for dealers who do not have any affected vehicles.  On or about October 13, 2016, this campaign code will show open on affected vehicles in Elsa.  On or about October 13, 2016, affected vehicles will be identified with this campaign code in the VIN Lookup tool at <a href="http://www.vw.com">www.vw.com</a> and on the NHTSA VIN lookup tool at <a href="http://www.safercar.gov">www.safercar.gov</a> .
<b>Owner Notification</b>	Owner notification will begin in October. Owner letter examples are included in this bulletin for your reference.
<b>Additional Information</b>	<b>Please alert everyone in your dealership about this action, including Sales, Service, Parts and Accounting personnel. Contact Warranty if you have any questions.</b>  <b>IMPORTANT REMINDER ON VEHICLES AFFECTED BY SAFETY &amp; COMPLIANCE RECALLS</b> <b><u>New Vehicles in Dealer Inventory:</u> It is a violation of Federal law for a dealer to deliver a new motor vehicle or any new or used item of motor vehicle equipment (including a tire) covered by this notification under a sale or lease until the defect or noncompliance is remedied. By law, dealers must correct, prior to delivery for sale or lease, any vehicle that fails to comply</b>

with an applicable Federal Motor Vehicle Safety Standard or that contains a defect relating to motor vehicle safety.

**Pre-Owned Vehicles in Dealer Inventory: Dealers should not deliver any pre-owned vehicles in their inventory which are involved in a safety or compliance recall until the defect has been remedied.**

Dealers must ensure that every affected inventory vehicle has this campaign completed before delivery to consumers.

Fill out and affix Campaign Completion Label (CAMP 010 000) after work is complete.

*Labels can be ordered at no cost via the Compliance Label Ordering portal at [www.vwhub.com](http://www.vwhub.com).*

### Claim Entry Instructions

After campaign has been completed, enter claim as soon as possible to help prevent work from being duplicated elsewhere. Attach the Elsa screen print showing action open on the day of repair to the repair order.

If customer refused campaign work:

- ✓ U.S. dealers: Submit request via WISE under the *Campaigns/Update/Recall Closure* option.
- ✓ Canada dealers: Fax repair order to Warranty at (905) 428-4811.

<b>Service Number</b>	20Y6									
<b>Damage Code</b>	0099									
<b>Parts Vendor Code</b>	WWO									
<b>Claim Type</b>	Sold vehicle: 7 10 Unsold vehicle: 7 90									
<b>Causal Indicator</b>	Mark suction pump as causal part*									
<b>Vehicle Wash/Loaner</b>	Do not claim wash/loaner under this action									
<b>Criteria I.D.</b>	01									
	Replace Suction Pump. Labor operation:      2066 23 99                      110 T.U. <table border="1"><thead><tr><th>Quantity</th><th>Part Number</th><th>Description</th></tr></thead><tbody><tr><td>1</td><td>5Q0201029</td><td>Suction Pump*</td></tr><tr><td>1</td><td>1J0919133B</td><td>Seal</td></tr></tbody></table>	Quantity	Part Number	Description	1	5Q0201029	Suction Pump*	1	1J0919133B	Seal
Quantity	Part Number	Description								
1	5Q0201029	Suction Pump*								
1	1J0919133B	Seal								

## Customer Letter Example (USA)

This notice applies to your vehicle: <VIN>

NHTSA: <INSERT NUMBER>

**Subject: Safety Recall 20Y5 – Suction Pump  
Certain 2015-2016 Model Year Volkswagen Golf, GTI & Golf SportWagen Vehicles**

Dear Volkswagen Owner,

This notice is sent to you in accordance with the National Traffic and Motor Vehicle Safety Act. Volkswagen has decided that a defect, which relates to motor vehicle safety, exists in certain 2015-2016 model year Volkswagen Golf, GTI & Golf SportWagen vehicles. Our records show that you are the owner of a vehicle affected by this action.

<b>What is the issue?</b>	The suction pump inside the fuel tank designed to purge fuel from the evaporative emissions (EVAP) system may have been damaged during assembly. This could cause fuel to flow directly into the EVAP system which could, over time, accumulate and cause a leak through the charcoal canister filter element. Leaking fuel, in the presence of an ignition source, may result in a fire.
<b>What will we do?</b>	To help correct this defect, your authorized Volkswagen dealer will replace the suction pump inside the fuel tank. This work will take less than two hours to complete and will be performed for you free of charge.
<b>What should you do?</b>	Please contact your authorized Volkswagen dealer without delay to schedule this recall repair. For your convenience, you can also visit <a href="http://www.vw.com">www.vw.com</a> and click on the "Owners" link to locate a dealer near you and schedule this service online.
<b>Precautions you should take</b>	If you smell fuel in the vehicle, immediately contact the nearest authorized Volkswagen dealer to have the vehicle inspected.  Additionally, you may experience refueling issues (early stopping of the fuel nozzle and fuel spillback) when fuel accumulates in the EVAP system. If this happens, immediately contact the nearest authorized Volkswagen dealer to have the vehicle inspected.
<b>Lease vehicles and address changes</b>	If you are the lessor and registered owner of the vehicle identified in this action, the law requires you to forward this letter immediately via first-class mail to the lessee within ten (10) days of receipt. If you have changed your address or sold the vehicle, please fill out the enclosed prepaid Owner Reply card and mail it to us so we can update our records.
<b>Reimbursement of Expenses</b>	If you have previously paid for repairs relating to the condition described in this letter, please refer to the enclosed form that explains how to request reimbursement.
<b>Can we assist you further?</b>	If your authorized Volkswagen dealer fails or is unable to complete this work free of charge within a reasonable time, or if you should have any questions about this communication, please reach out to us using your preferred method of communication at <a href="http://www.vw.com/contact">www.vw.com/contact</a> or by calling 1 800-893-5298. Our phone team is available Monday through Friday from 8AM to 10PM EST and Saturday from 9AM to 5PM EST.
<b>Checking your vehicle for open Recalls and Service Campaigns</b>	To check your vehicle's eligibility for repair under this or any other recall/service campaign, please click on the <b>Look Up Recalls</b> link at <a href="http://www.vw.com">www.vw.com</a> and enter your Vehicle Identification Number (VIN) into the <b>Recall/Service Campaign Lookup</b> tool.

If you still cannot obtain satisfaction, you may file a complaint with: The Administrator, National Highway Traffic Safety Administration, 1200 New Jersey Avenue, SE., Washington, DC 20590; or call the toll-free Vehicle Safety Hotline at 1-888-327-4236 (TTY: 1-800-424-9153); or go to <http://www.safercar.gov>.

We apologize for any inconvenience this matter may cause; however we are taking this action to help ensure your safety and continued satisfaction with your vehicle. Thank you for driving a Volkswagen!

Sincerely,

Volkswagen Customer Protection

## Customer Letter Example (CANADA)

<MONTH YEAR>

<CUSTOMER NAME>

<CUSTOMER ADDRESS>

<CUSTOMER CITY STATE ZIPCODE>

**This notice applies to your vehicle:** <VIN>

**Subject: Safety Recall 20Y5 – Suction Pump  
Certain 2015-2016 Model Year Volkswagen Golf, GTI & Golf SportWagen Vehicles**

Dear Volkswagen Owner,

This notice is sent to you in accordance with the requirements of the Motor Vehicle Safety Act. Volkswagen has decided that a defect, which relates to motor vehicle safety, exists in certain 2015-2016 model year Volkswagen Golf, GTI & Golf SportWagen vehicles. Our records show that you are the owner of a vehicle affected by this action.

- What is the issue?** The suction pump inside the fuel tank designed to purge fuel from the evaporative emissions (EVAP) system may have been damaged during assembly. This could cause fuel to flow directly into the EVAP system which could, over time, accumulate and cause a leak through the charcoal canister filter element. Leaking fuel, in the presence of an ignition source, may result in a fire.
- What will we do?** To help correct this defect, your authorized Volkswagen dealer will replace the suction pump inside the fuel tank. This work will take less than two hours to complete and will be performed for you free of charge.
- What should you do?** Please contact your authorized Volkswagen dealer without delay to schedule this recall repair.
- Precautions you should take** If you smell fuel in the vehicle, immediately contact the nearest authorized Volkswagen dealer to have the vehicle inspected.  
  
Additionally, you may experience refueling issues (early stopping of the fuel nozzle and fuel spillback) when fuel accumulates in the EVAP system. If this happens, immediately contact the nearest authorized Volkswagen dealer to have the vehicle inspected.
- Lease vehicles and address changes** If you are the lessor and registered owner of the vehicle identified in this action, the law requires you to forward this letter immediately via first-class mail to the lessee within ten (10) days of receipt. If you have changed your address or sold the vehicle, please fill out the enclosed prepaid Owner Reply card and mail it to us so we can update our records.
- Reimbursement of Expenses** If you have previously paid for repairs relating to the condition described in this letter, please refer to the enclosed form that explains how to request reimbursement.
- Can we assist you further?** If your authorized Volkswagen dealer fails or is unable to complete this work free of charge within a reasonable time, please contact Customer Relations, Monday through Friday from 8AM to 8PM EST by phone at 1-800-822-8987 or via our "Contact Us" page at [www.vw.ca](http://www.vw.ca).

We apologize for any inconvenience this matter may cause; however we are taking this action to help ensure your safety and continued satisfaction with your vehicle. Thank you for driving a Volkswagen!

Sincerely,

Volkswagen Customer Protection

**NOTE**

Damages resulting from improper repair or failure to follow these work instructions are the dealer's responsibility and are not eligible for reimbursement under this action.

**Required Parts**

<u>Quantity</u>	<u>Part Number</u>	<u>Part Description</u>
1	5Q0-201-029	Suction Pump
1	1J0-919-133-B	Seal

**Required Tools**

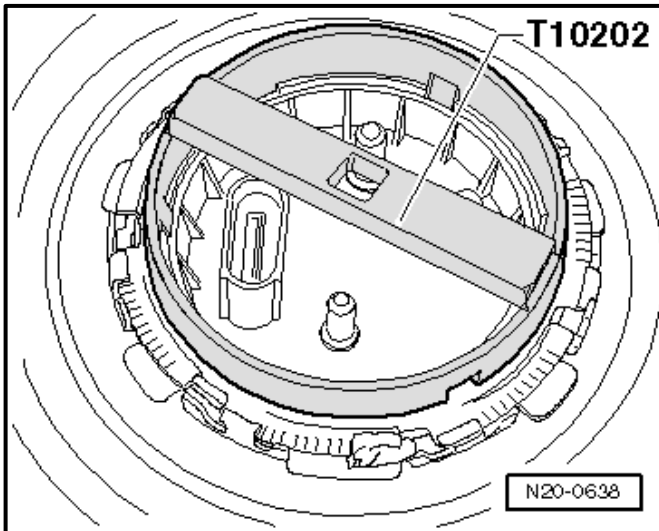

- Wrench - Fuel Sending Unit -T10202-

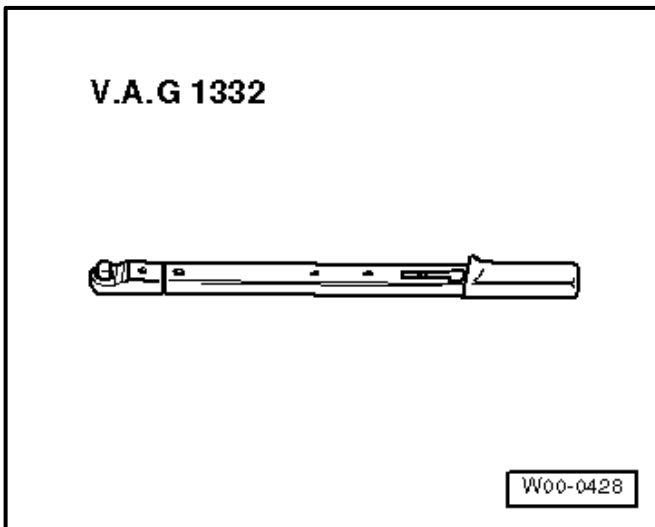

- Torque Wrench 1332 40-200Nm -VAG1332- (or equivalent)

3409

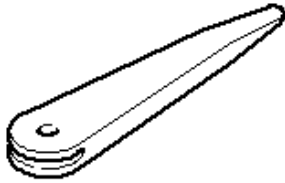

VW00-0016

- Trim Removal Wedge -3409-



- VAS6150D - Diagnostic Tester (or equivalent)
- VAS6154 - Vehicle Communication Interface (or equivalent)



- GRX3000VAS – Battery Tester/Charger (or equivalent)

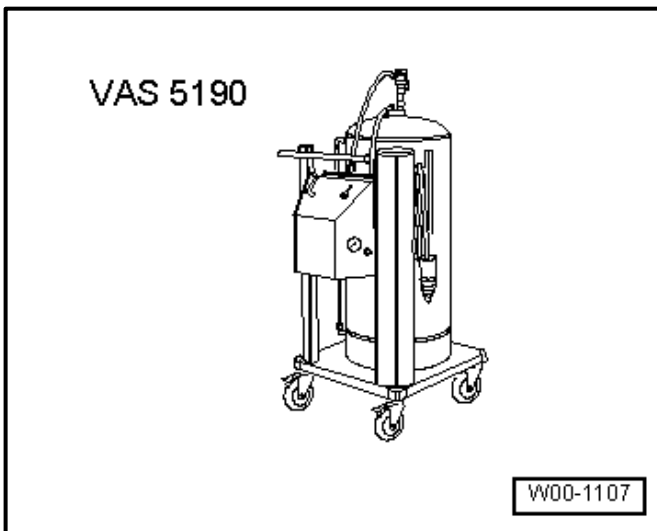

- Fuel Extractor VAS5190A -VAS5190-





## Repair Instruction

### Section A - Check for Previous Repair

#### TIP

If Campaign Completion label is present, no further work is required.

Applicable criteria ID(s)	Campaign/Action Status
01 	Open 

**EXAMPLE**

- Enter the VIN in Elsa and proceed to the “Campaign/Action” screen.

#### TIP

On the date of repair, print this screen and keep a copy with the repair order.

- Confirm the Campaign/Action is open <arrow 1>. If the status is closed, no further work is required.
- Note the Applicable Criteria ID <arrow 2> for use in determining the correct work to be done and corresponding parts associated.

**Proceed to Section B**

## Section B – Repair Procedure

### NOTE

Due to variations in vehicle equipment and options, the steps/illustrations in this work procedure may not identically match all affected vehicles.

### NOTE

Follow these “rules” when working on the fuel supply/injector system:

- Thoroughly clean the connecting points and the surrounding area before loosening.
- Place the removed parts on a clean surface and cover them. Only use lint-free cloths!
- Carefully cover or seal opened components if the repair will not be done immediately.
- Only install clean parts: remove replacement parts from the packaging immediately prior to installation. Do not use parts that have been stored loose (for example, in tool boxes etc.).
- When the system is open: do not work with compressed air.
- Do not move vehicle.
- Seal off any open lines and connections immediately with plugs, for example, take from -VAS6122-.
- Protect the disconnected connectors from dirt and moisture and only connect when they are dry.

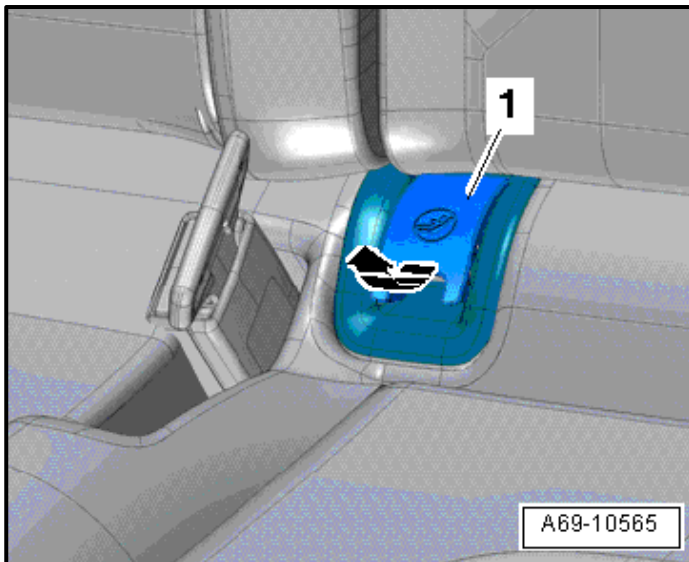

- Move the front seats all the way forward.
- Unclip and remove the covers <1> from the LATCH child seat anchors <arrow>.

### CAUTION

Edges on the child seat anchor cover may be sharp.

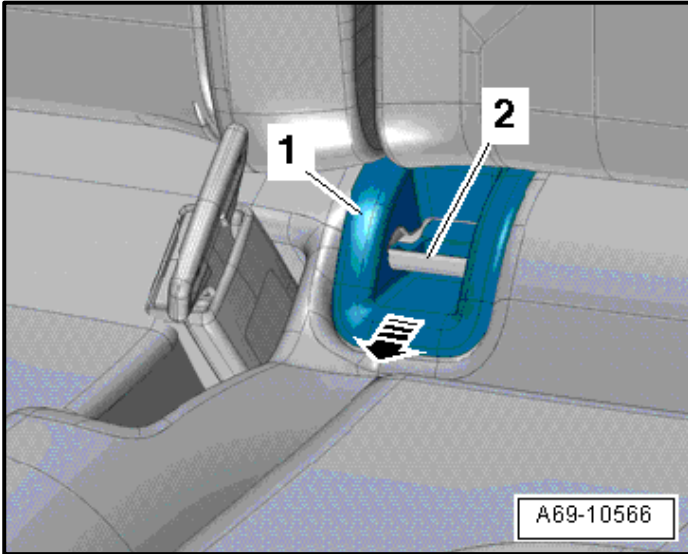

- Push the guides <1>, corresponding to cut-out, downward and disengage them from the LATCH child seat anchors <2>.

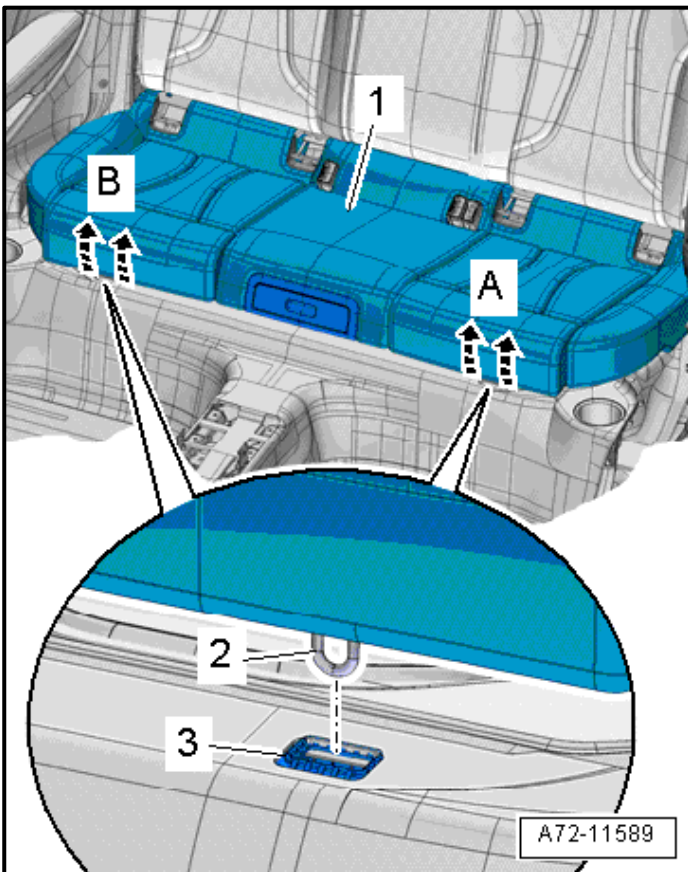

- With both hands, grasp the rear bench seat under the seat frame.
- Pull the rear bench seat <1> up forcefully with both hands <arrows A> so the wire hooks <2> on the rear bench seat release from the mounting grommet <3>.
- Repeat the procedure on the other side of the rear bench seat <arrows B>.

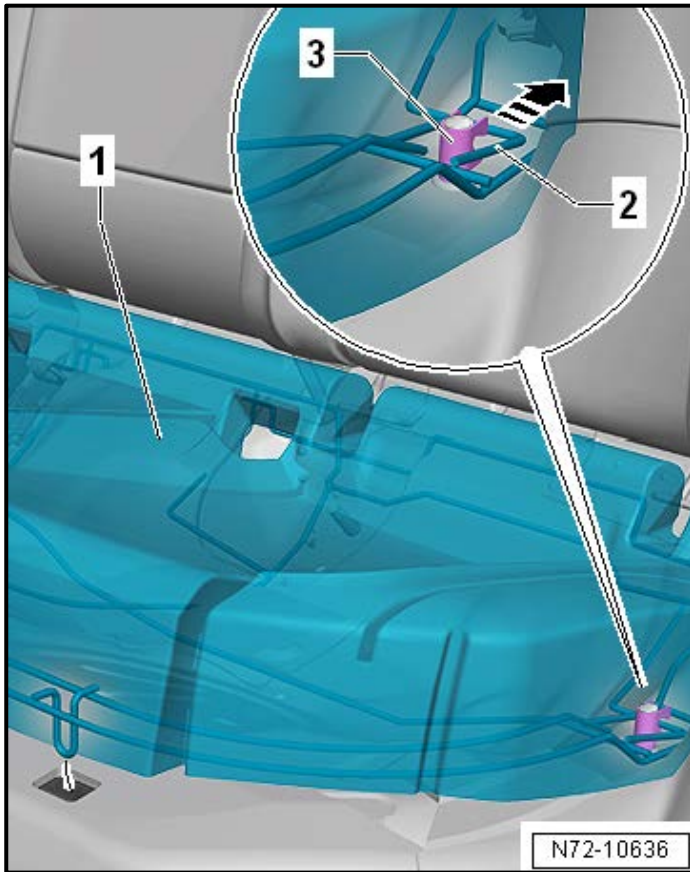

- Gently lift the rear bench seat <1> at front and slide the wire frame <2> out of the hook <3> toward the rear.
- Remove the rear bench seat from the vehicle.

**NOTE**

Place the seat bench in a clean location where it will not be damaged. Damage to the seat bench is not covered under this action.

**CAUTION**

**Danger due to escaping fuel**

- To prevent large quantities of fuel from leaking from the fuel delivery unit when removing, the fuel tank may only be a maximum of  $\frac{3}{4}$  full

- Drain the fuel tank.
  - If fuel tank is more than  $\frac{3}{4}$  full, proceed to subsection 1.
  - If fuel tank is less than  $\frac{3}{4}$  full, proceed to subsection 2.

## Subsection 1 – Fuel Tank More Than ¾ Full

### NOTE

Use only the Fuel Extractor Unit -VAS5190A- when extracting E 85 - fuel!

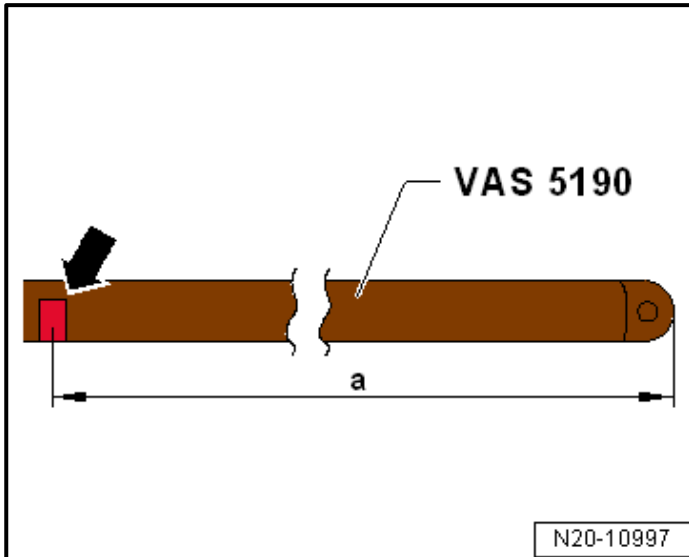

- Use insulating tape to mark the hose <arrow> at the distance <a> from the end of the suction hose on the -VAS5190-.

Rear Axle	Distance of <a>
Multi-link	945 mm
Torsion Beam Rear Suspension	1010 mm

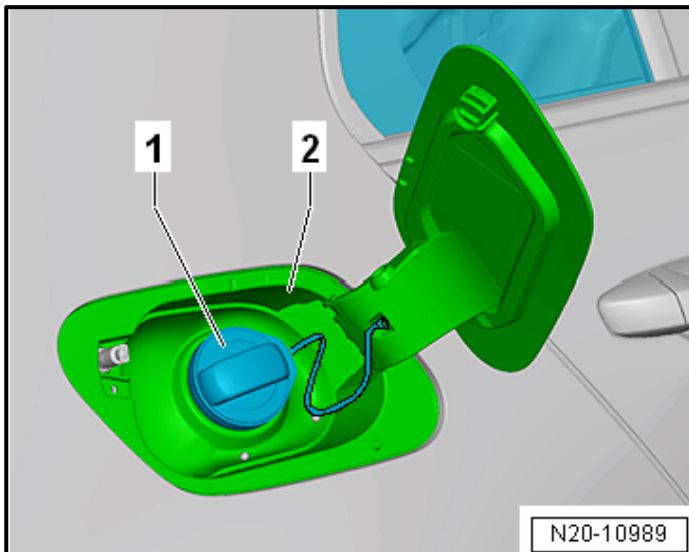

- Open the fuel filler door unit.
- Clean the area around the fuel filler neck<2>.
- Remove the cap <1> for the fuel filler neck.
- Attach the ground wire from the -VAS5190A- to a bare area on the body.

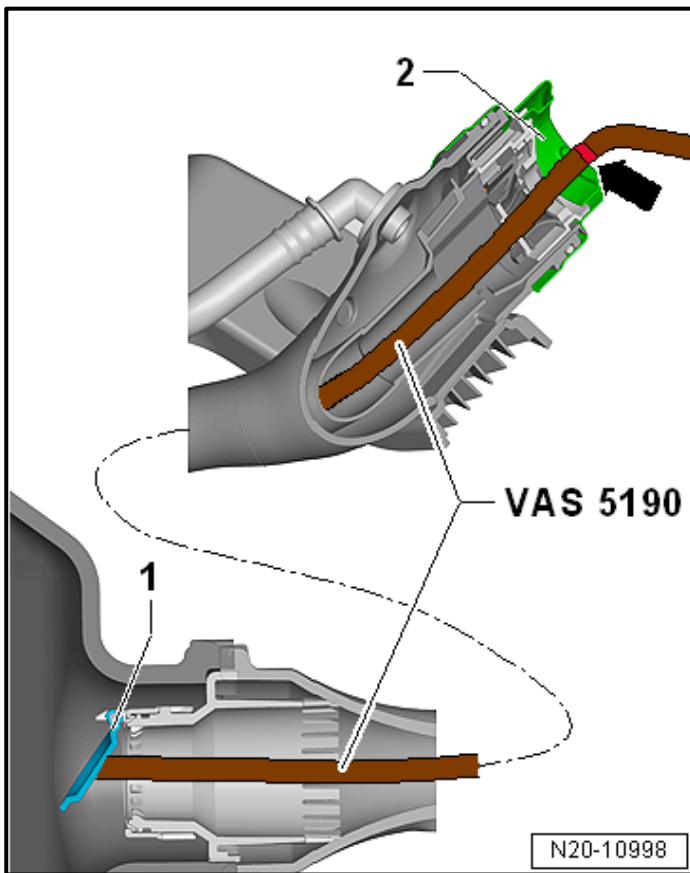

- Slide the suction hose from the -VAS5190A- into the fuel tank until the previously made mark -arrow- meets the filler neck <2>.
- Drain the fuel tank as much as possible through the filler neck.

#### NOTE

- A valve <1> is located in the fuel tank on the lower end of the filler neck. It must not be damaged by the suction hose. Only slide the hose in as far as the mark that was made earlier <arrow>.
- Do not use force to remove the suction hose if it gets stuck on the check valve.
- In this case, remove the fuel delivery unit and manually hold the check valve open. When doing this, make sure your arm does not come in contact with the fuel.
- When no more fuel can be extracted, the fuel tank is only emptied enough so that the sensor flange can be opened safely.
- Carefully remove the suction hose.
- **Proceed to Subsection 2.**

### Subsection 2 – Fuel Tank Less Than $\frac{3}{4}$ Full

#### WARNING

- The fuel system is under high pressure.
- Risk of injury from fuel spraying out.
- Reduce the pressure before continuing procedure.

#### Risk of a fire due to leaking fuel.

- When the battery is connected, the door contact switch activates the fuel pump when opening the driver door. Leaking fuel can ignite and start a fire.
- Before opening the fuel system, interrupt the power supply to the fuel pump.

- Attach the GRX3000VAS Tester/Charger (or equivalent) to the vehicle battery.
- Turn on the ignition and connect the VAS6150D Diagnostic Tester (or equivalent) to the vehicle.
- Select the following menu items on the Vehicle Diagnostic Tester:
  - 01 – Engine Electronics
  - Guided Functions
  - 01 – Reduce high fuel pressure
- Once the fuel pressure has been reduced, switch off the ignition.

**CAUTION**

- The fuel rail will continue to be filled with fuel, but it will no longer be under high pressure.
- If the high pressure system is not opened immediately after reducing the pressure, the pressure will increase because of post-heating.
- The ignition must not be switched on again, otherwise the pressure will increase again.

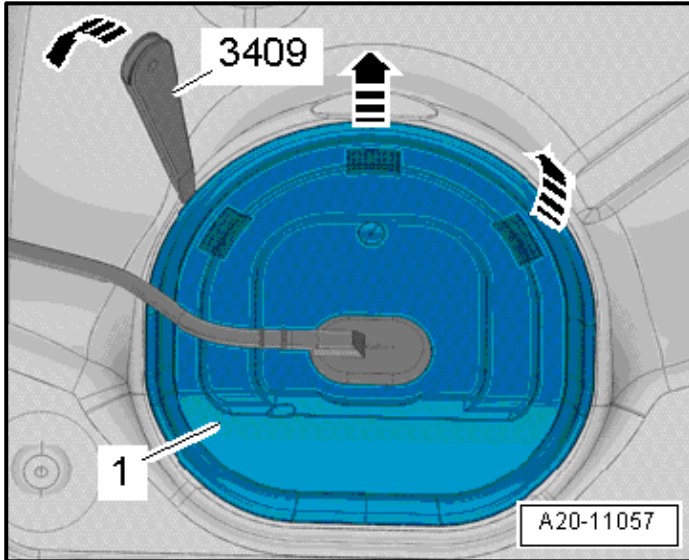

- Disconnect the ground cable from the battery terminal.
- In the rear seat, unclip the sealing flange cover <1> at the tabs <arrows> using the Trim Removal Wedge -3409.

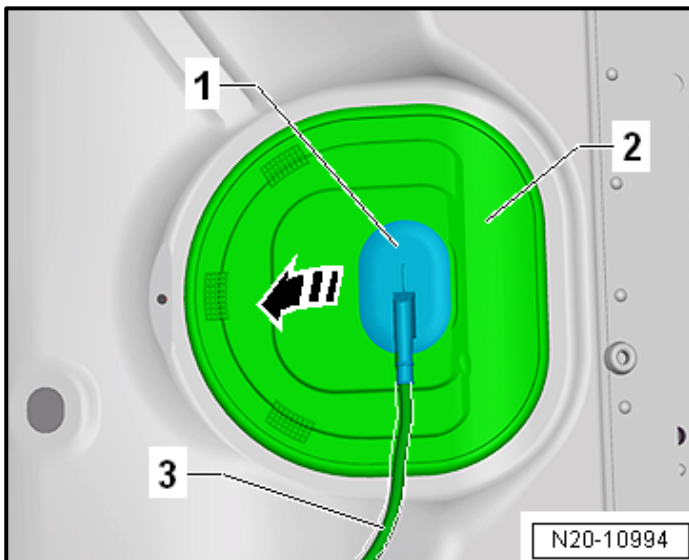

- Unclip the grommet <1> downward out of the cover <2>.



- Prior to disassembly, the fuel delivery unit **MUST** be clean. If excessive dirt or debris is present <as shown>, clean and dry the fuel delivery unit and surrounding areas as necessary.

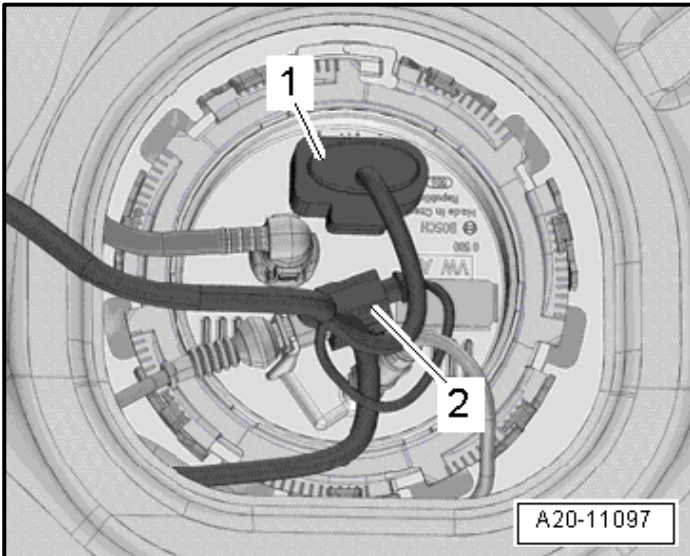

- Unlock and disconnect the connector <1> from the sealing flange.
- If equipped, disengage the connector <2> for the parking heater Metering Pump -V54- on the sealing flange and move it to the side.



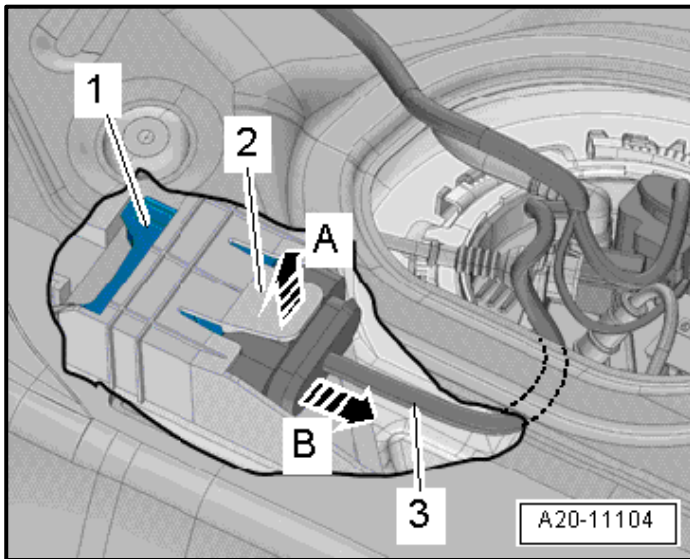

- Lift the tab <2> in the direction of the <arrow A>. To do so, reach a finger between the floor panel and the fuel tank.
- At the same time, carefully pull the Fuel Pump Control Module -J538- <1> out of the mount at the wiring harness <3> in the direction of the <arrow B>.
- Remove the Fuel Pump Control Module -J538- toward the inside between the fuel tank and the floor panel.
- Move the Fuel Pump Control Module -J538- together with the wiring harness to the side.

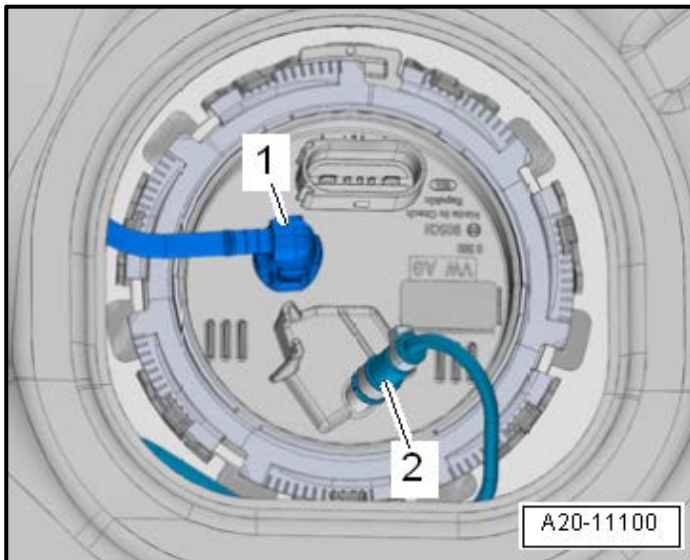

### ⚠ WARNING

Fuel Lines are under pressure. Danger of personal injury to eyes and skin. Wear protective eyewear and protective clothing in order to avoid injury and contact with the skin. Wrap a cloth around the connection **before** loosening hose connections. Open the connection carefully and release the pressure.

### ⓘ NOTE

When disconnecting fuel lines, press the release button on the connecting piece.

- Remove the fuel line <1> from the sealing flange. Disconnect the connector couplings.
- If equipped, remove the fuel line <2> to the Metering Pump -V54- for the parking heater on the sealing flange by loosening the lower hose clamp.

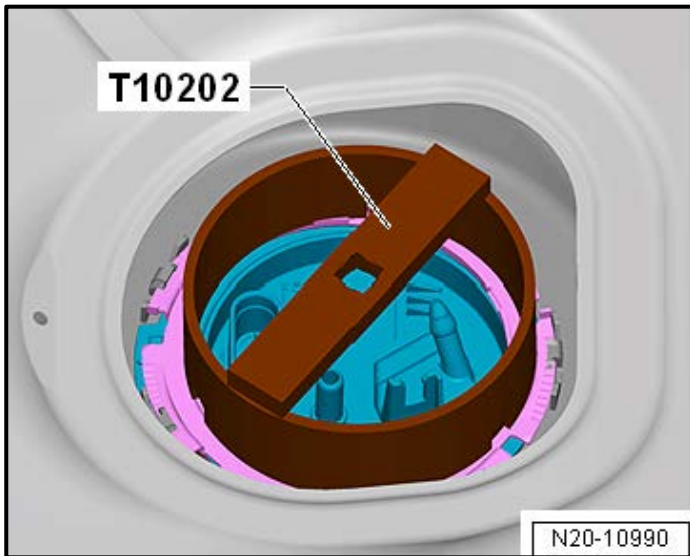

- Open the locking ring using the Wrench - Fuel Sending Unit -T10202-.
- Carefully lift the fuel delivery unit flange.

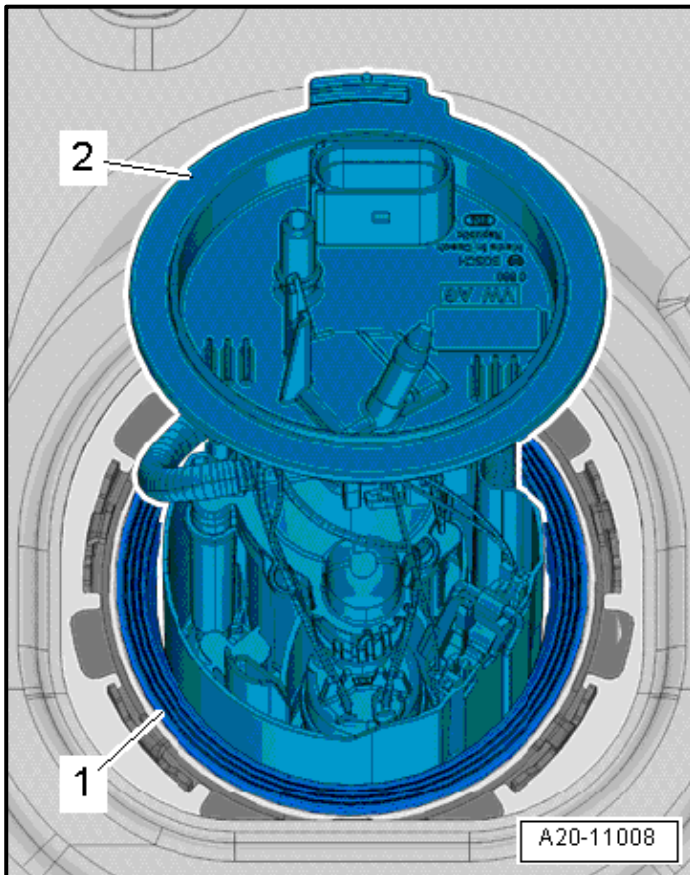

- Pull the sealing flange <2> out of the opening in the fuel tank slightly.
- Remove the seal <1> and slightly lift the fuel delivery unit flange again carefully.

**NOTE**

Use only the Fuel Extractor Unit -VAS5190A- when extracting E 85 - fuel!

- Attach the ground wire of the -VAS5190- to a bare area on the body.
- Insert the suction hose for the -VAS5190- as deep as possible into the fuel tank.
- Extract the fuel using the -VAS5190-.
- Insert the extraction hose into the fuel delivery unit.
- Drain as much fuel as possible from the fuel delivery unit itself.

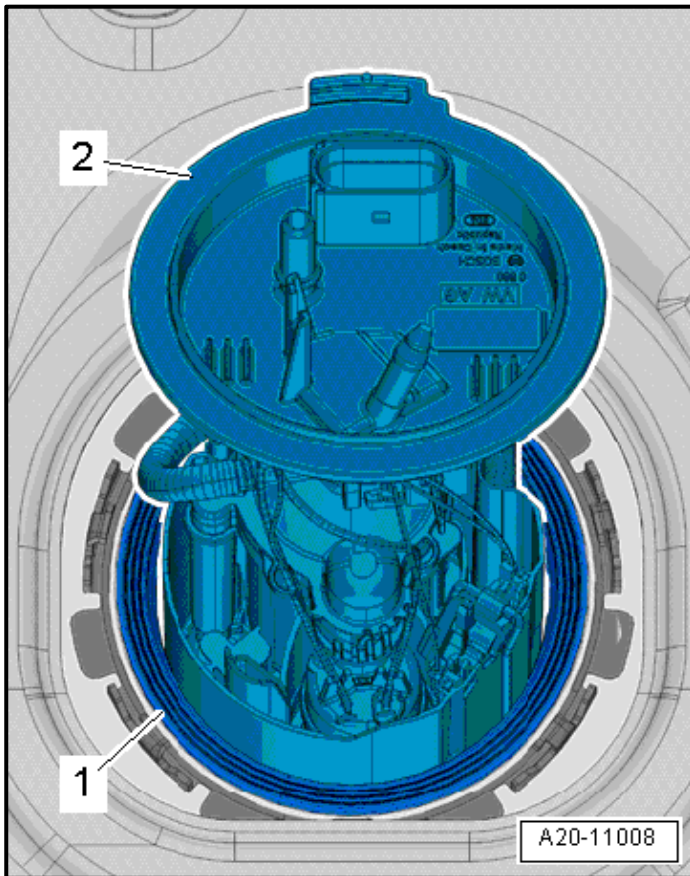

- Once the fuel has been properly evacuated, carefully pull the fuel delivery unit with the fuel level sensor out through the opening in the fuel tank, using caution not to bend the floater arm on the fuel level sensor when removing.

**⚠ CAUTION**

During removal of the fuel delivery unit, it is very easy to damage the fuel level sensor. Use caution when removing the fuel delivery unit. Damage to the fuel level sensor is not covered under this action.

- Place a cloth underneath to catch the residual fuel, since the fuel delivery unit may still be partially filled.

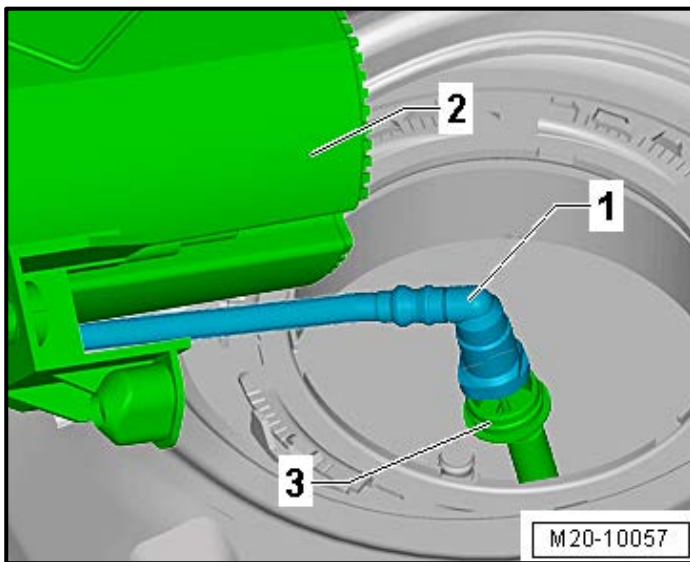

- Carefully pull the fuel delivery unit <2> out of the fuel tank, release the fuel line <1> and disconnect it from the front suction line <3>.
- Lay a cloth inside the vehicle to absorb any residual fuel.

**! NOTE**

- Follow all waste disposal regulations.
- Check the fuel tank for contamination.

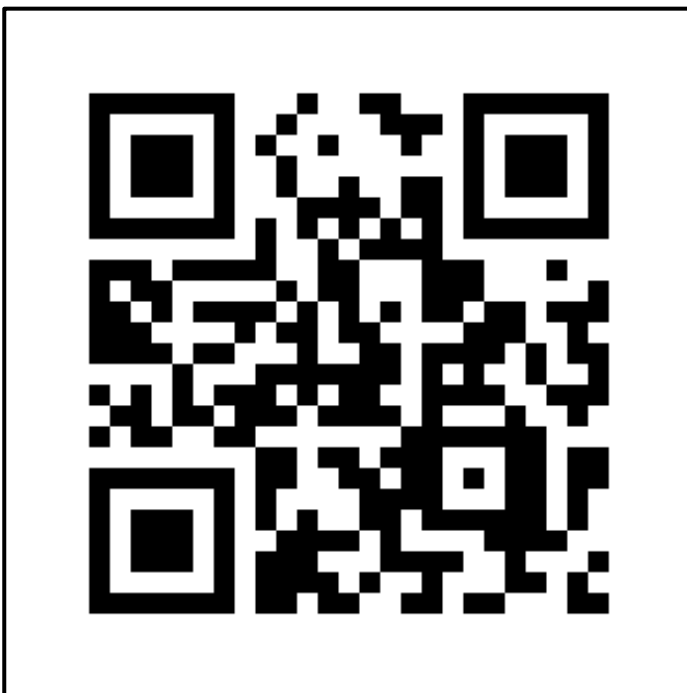
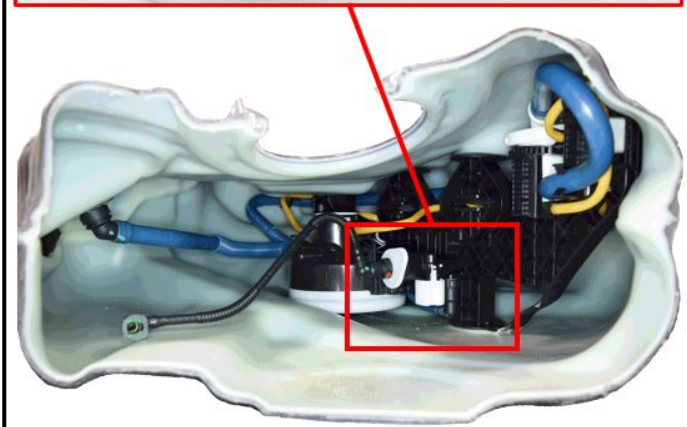
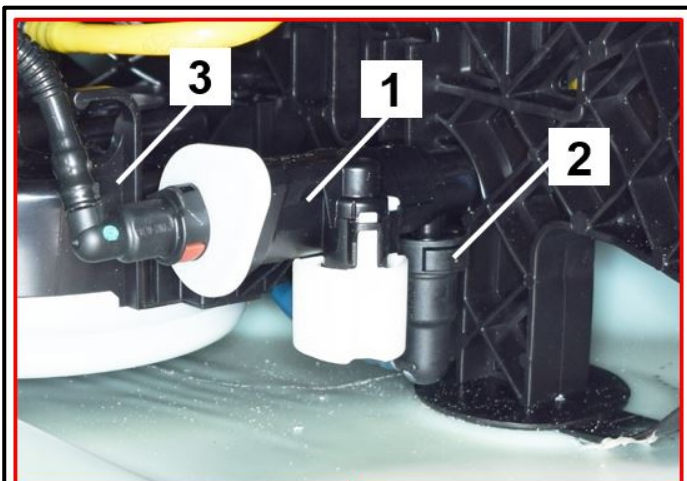

**NOTE**

- The fuel tank in the illustration below has been sectioned to provide a clear view of the suction valve.
- Under no circumstances should the fuel tank be altered or modified as shown below.

- Reach into the fuel tank and follow the black hose for finding the suction pump.
- Disconnect the rear suction line <2> by pushing the quick release connector latch and down on the hose.
- Remove the suction pump <1> off the retainer bracket <3> by slightly rotating away from the fuel tank, using caution not to damage the attached front suction line.

- To view a short video overview on removing and reinstalling the suction pump, scan the QR code to the left.

**TIP**

The QR code is for viewing the video on smartphones and tablets. Alternatively, the video can also be accessed through computer internet browsers with the link below:

[https://youtu.be/O1H7\\_8IRTVI](https://youtu.be/O1H7_8IRTVI)

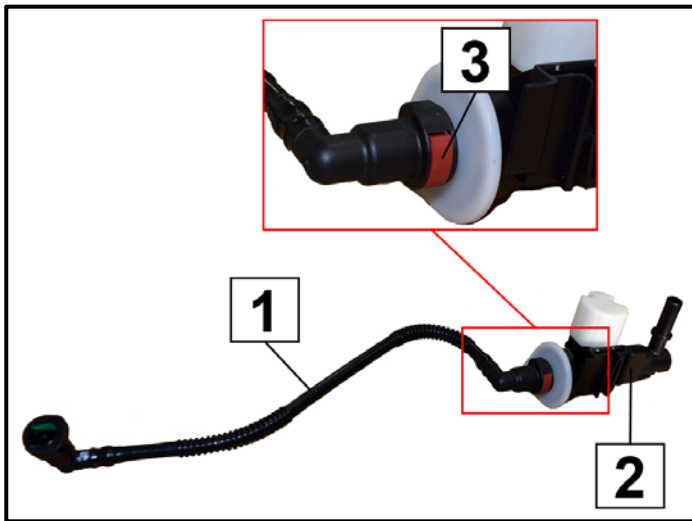

- Release the retainer <3> and transfer the front suction line <1> from the old suction pump <2> to the new suction pump, ensuring that the locking of the retention clip <3> is felt and/or heard.

Part Number	Part Description
5Q0-201-029	Suction Pump

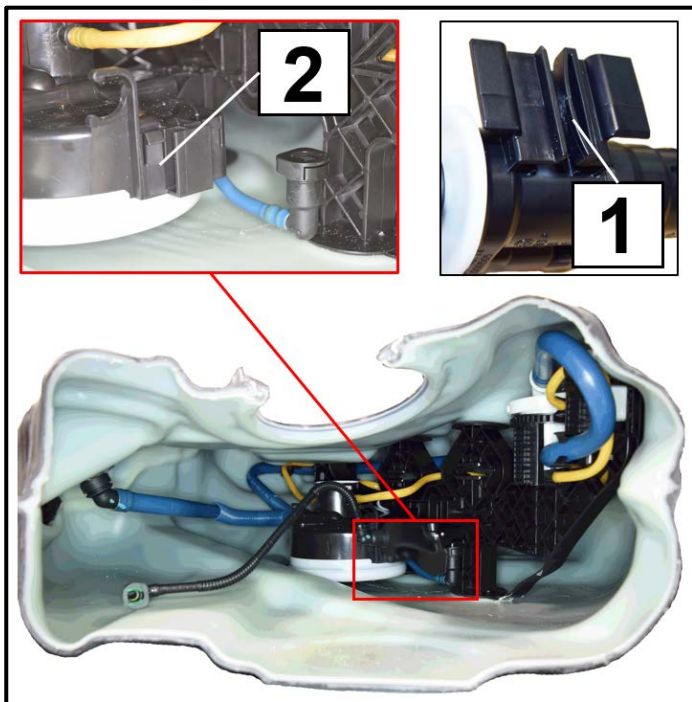

- Insert the suction pump into the fuel tank, using caution not to damage the attached front suction line during installation.
- Align the retention clip on the suction pump <1> to the bracket in the fuel tank <2>, and install the new suction pump into the tank, ensuring that the pump is secured firmly on the bracket <2>.

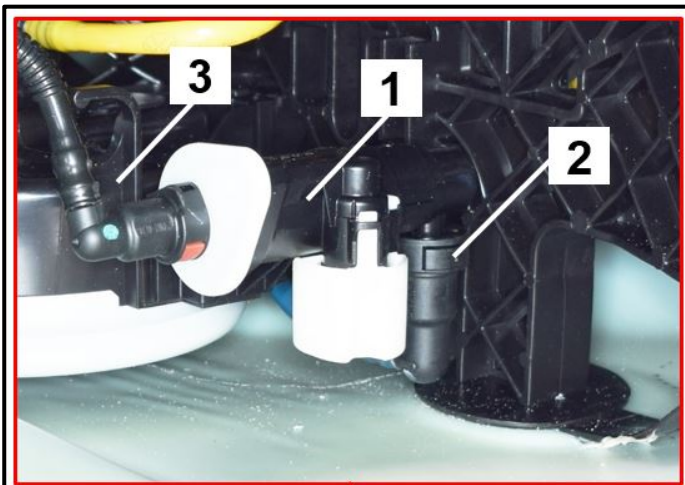

- Reconnect the rear suction line <2> to the suction pump <1>, ensuring that the locking of the retention clip is felt and/or heard.
- Ensure that the front suction line <3> is firmly seated and secure.

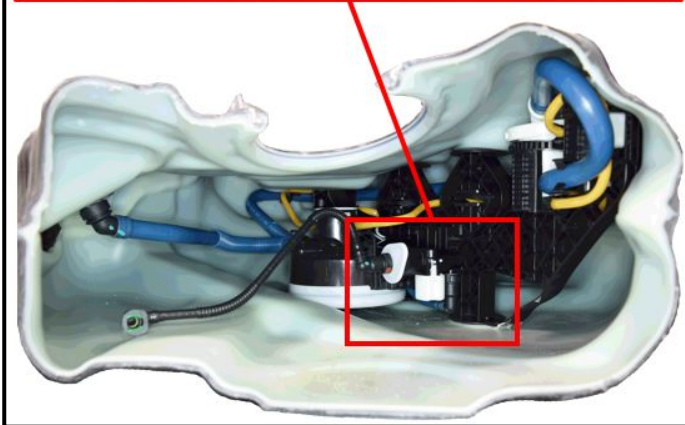

- Coat the inside of the new fuel delivery unit seal <1> with fuel and install into the opening in the fuel tank.

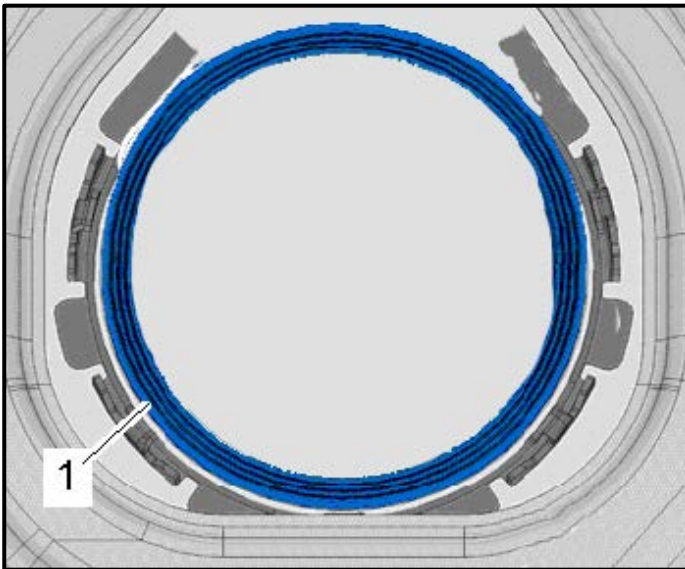

Part Number	Part Description
1J0-919-133-B	Seal

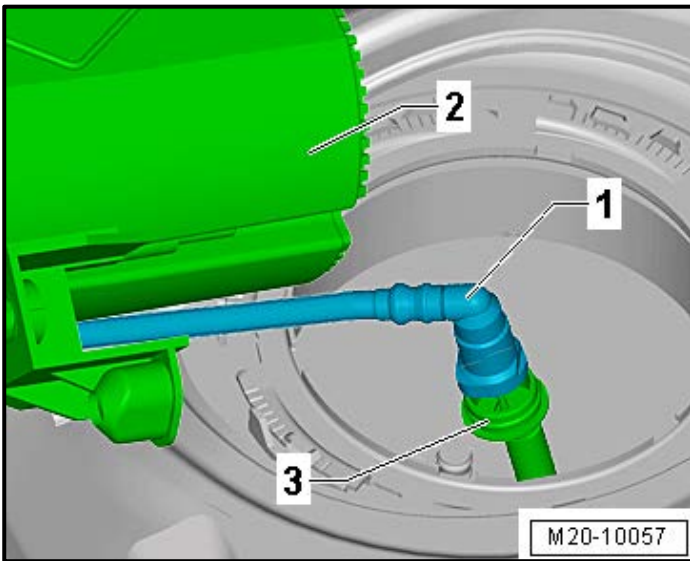

**NOTE**

When reconnecting fuel lines, ensure that the locking of the retention clip is felt and/or heard.

- Carefully align the fuel delivery unit <2> to the fuel tank and reconnect the fuel line <1> to the front suction line <3>.

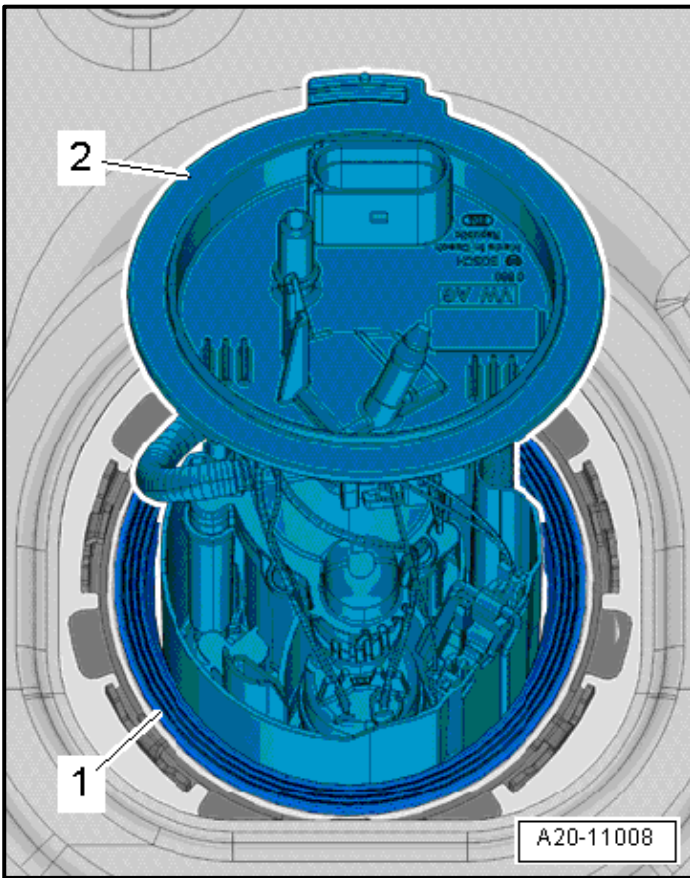

- Reinstall the fuel delivery unit, using caution not to bend the fuel level sensor when installing.

**CAUTION**

Be careful not to bend the fuel level sensor when installing the fuel delivery unit.

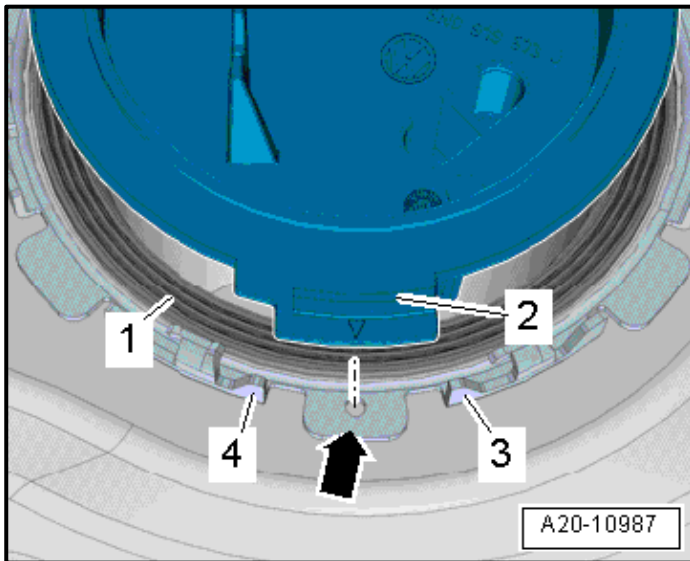

**NOTE**

When inserting the sealing flange, the seal must not be damaged or crushed.

- Push the sealing flange <2> down against the spring force.
- Bring the sealing flange into its installation position.

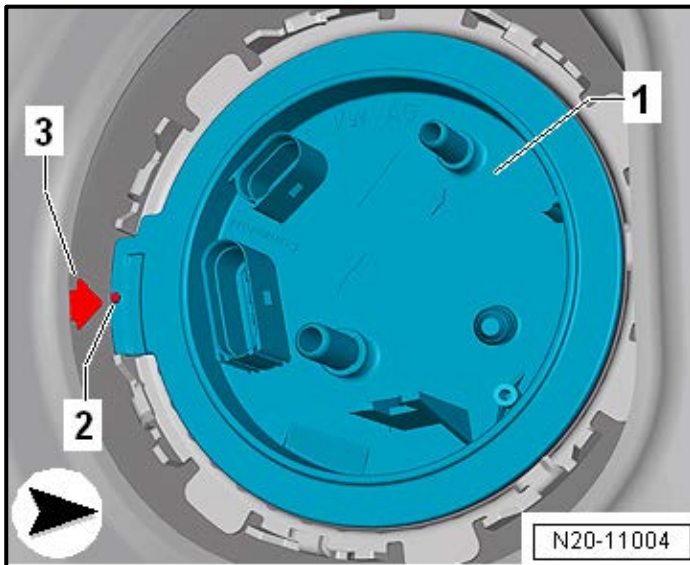

- The arrow <3> on the fuel tank must point to the mark <2> on the sealing flange <1>.



- Using the -T10202-, tighten the locking ring to 110 Nm.



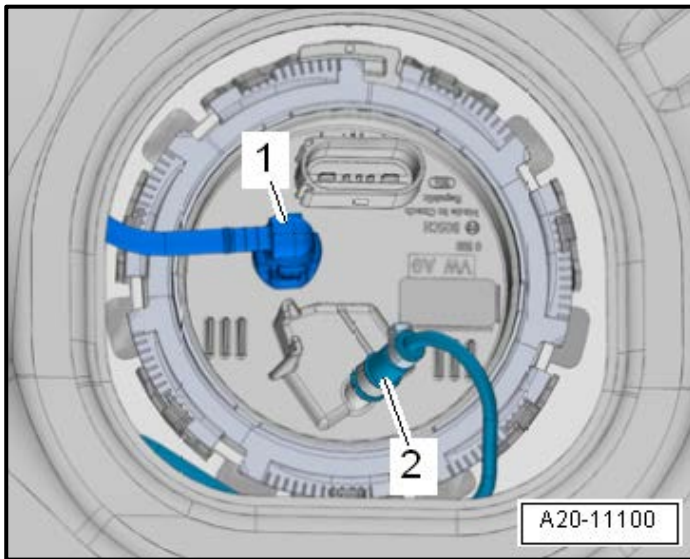

- Attach the fuel line <1> to the sealing flange until it clicks into place.
- If equipped, install the fuel line <2> to the Metering Pump -V54- for the parking heater on the sealing flange.

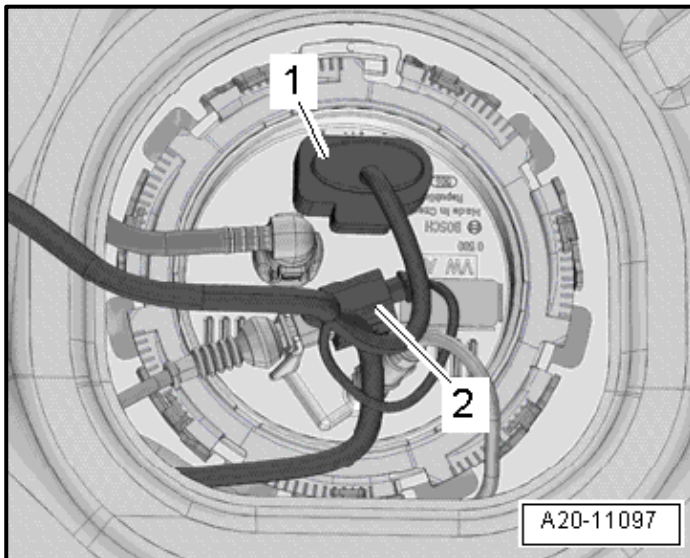

- Connect the connector <1>.
- If equipped, engage the connector <2> for the parking heater Metering Pump -V54- on the sealing flange.
- Gently pull on the connectors to make sure they are secure.

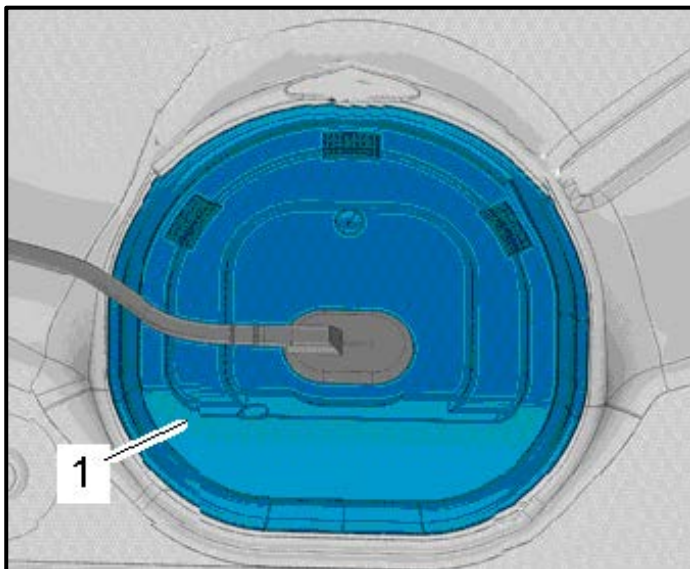

- Reattach the sealing flange cover <1>.

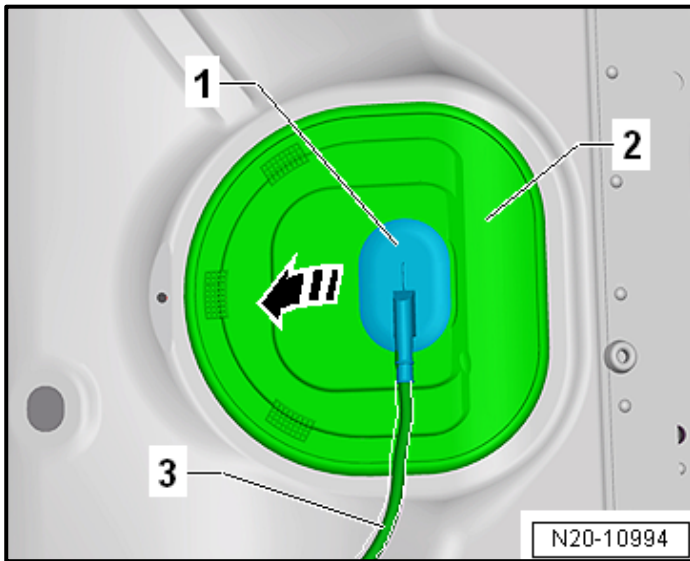

- Reattach the grommet <1> into the cover <2>.

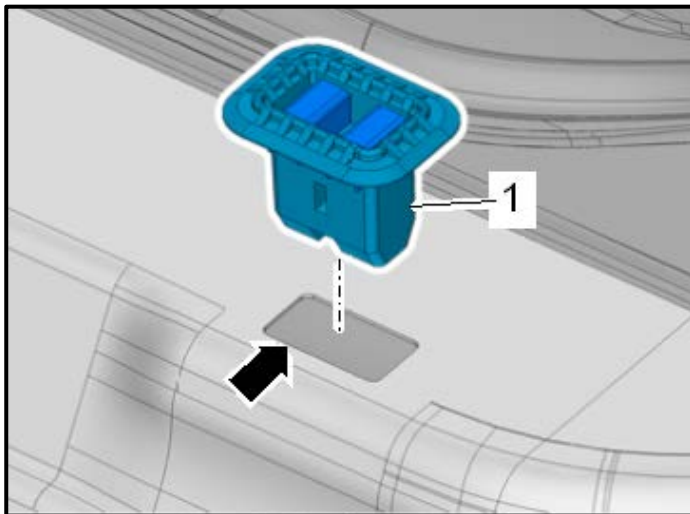

- Prior to reinstalling the rear seat, remove the grommets <1> and check the body openings <arrow> for deformations.
  - If deformation is found, readjust the panel with a plastic hammer.
- Lift the carpet <2> and press in the mounting grommets <1> until they engage audibly in body opening <arrow>.
- Ensure the carpet does not cover the grommet.

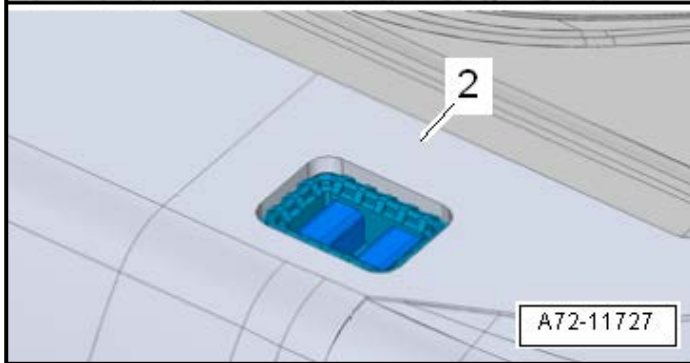

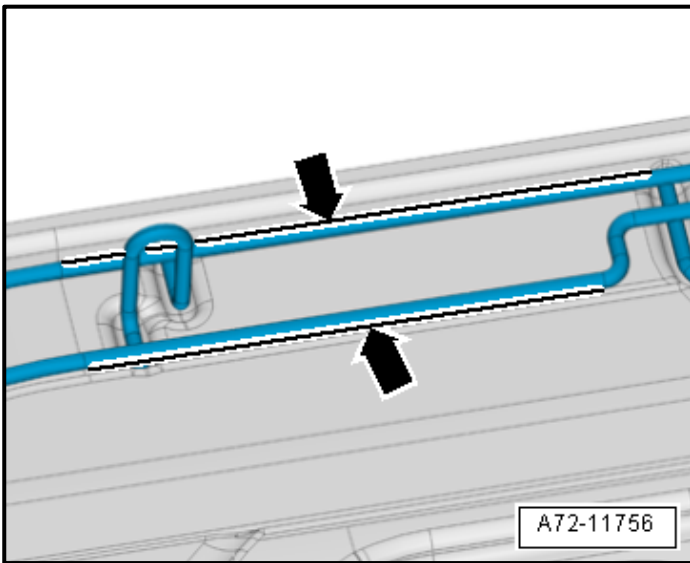

- Check if the wire frame is aligned in the marked area <arrows> before installing the rear bench seat.
- If the wire frame is bent, bend it back far enough until it is realigned.

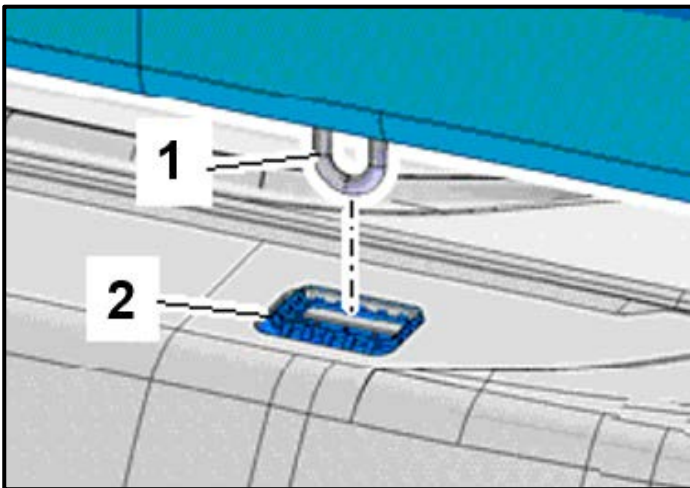

- Install the rear bench seat and push the wire hooks <1> into the mounting grommets <2>.

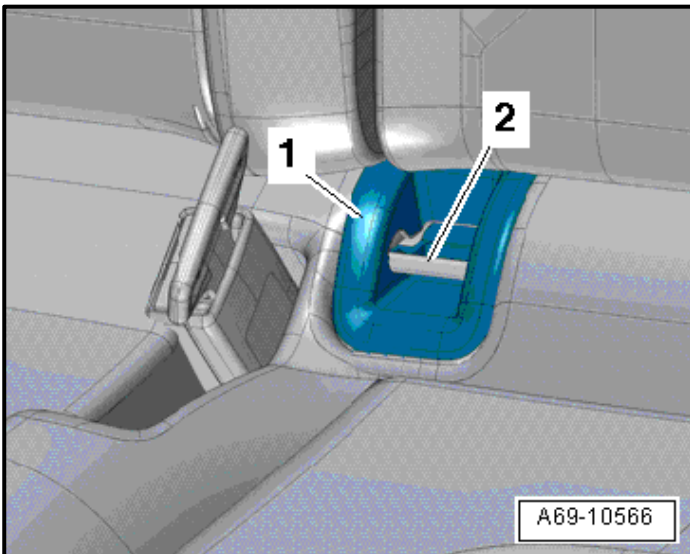

- Reinstall the guides <1> to the LATCH child seat anchors <2>.

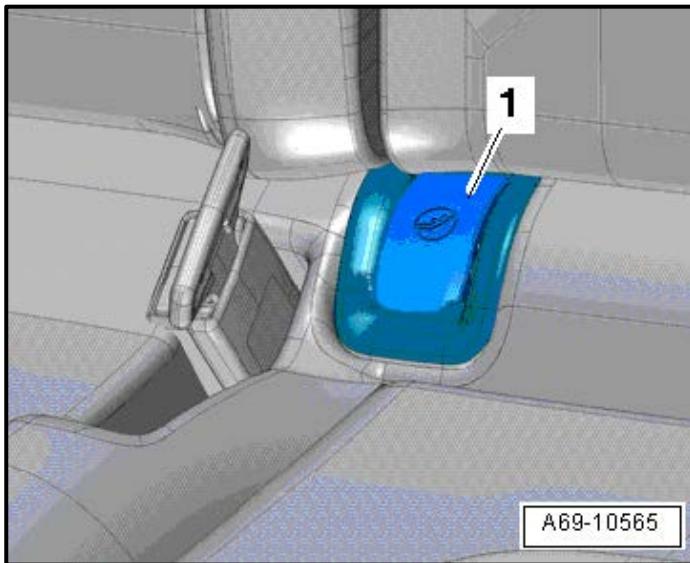

- Reinstall the covers <1> to the LATCH child seat anchors.

- Refill the fuel tank with the drained fuel.
- Reconnect the negative battery terminal.
- Switch the ignition ON.
- Attach an appropriate VAS tester to the vehicle.
- Clear all DTCs.
- Reset customer convenience basic settings (i.e. one touch windows, instrument cluster clock, etc.).

**Proceed to section C.**

## Section C – Campaign Completion Label

### Install Campaign Completion Label

- Fill out and affix Campaign Completion Label, part number CAMP 010 000, next to the vehicle emission control information label.

#### TIP

Ensure Campaign Completion Label does not cover any existing label(s).

- **Proceed to Section D.**

## Section D - Parts Return/Disposal

Properly store (retain), destroy or dispose of removed parts in accordance with all state/province and local requirements, unless otherwise indicated and/or requested through the Warranty Parts Portal (WPP).