



Michael A. Berardi
 Director
 Service Engineering Operations
 Ford Customer Service Division

Ford Motor Company
 P. O. Box 1904
 Dearborn, Michigan 48121

August 24, 2017

TO: All U.S. Ford and Lincoln Dealers

SUBJECT: DEMONSTRATION / DELIVERY HOLD - Safety Recall 16S30 - Supplement #6
 Certain 2013-2015 Model Year C-MAX and Escape, 2012-2015 Focus, 2015 MKC
 and Mustang, and 2014-2016 Transit Connect Vehicles
 Side Door Latch Replacement

New! REASON FOR THIS SUPPLEMENT

PARTS REQUIREMENTS / ORDERING INFORMATION: *As of August 24, 2017, all parts are now available through open ordering and the one-for-one replenishment plan has ended.*

AFFECTED VEHICLES

Vehicle	Model Year	Assembly Plant	Build Dates
C-MAX	2013-2015	Michigan	January 19, 2012 through January 31, 2015
Escape	2013-2015	Louisville	October 5, 2011 through January 31, 2015
Focus	2012-2015	Michigan	August 1, 2010 through January 31, 2015
MKC	2015	Louisville	August 20, 2013 through January 31, 2015
Mustang	2015	Flat Rock	February 11, 2014 through April 30, 2015
Transit Connect	2014-2016	Valencia (Spain)	August 1, 2013 through February 1, 2016

Affected vehicles are identified in OASIS and FSA VIN Lists.

REASON FOR THIS SAFETY RECALL

In the affected vehicles, the pawl spring tab in a side door latch may break, which may make the door difficult to latch. A door that opens while driving increases the risk of injury.

SERVICE ACTION

Before demonstrating or delivering any new in-stock vehicles, dealers are to replace the following door latches:

- C-MAX, Escape, Focus, MKC four side door latches
- Mustang two side door latches
- Transit Connect two sliding door latches

OWNER NOTIFICATION MAILING SCHEDULE

Owners in Arizona, Florida, Nevada, New Mexico, Oregon, Texas, and Utah were notified in January, 2017. Owners in the other 43 states will be notified in phases beginning in Second Quarter 2017. Dealers should repair any affected vehicles that arrive at their dealerships, whether or not the customer has received a letter.

PLEASE NOTE:

Federal law requires dealers to complete this recall service before a new vehicle is delivered to the buyer or lessee. Violation of this requirement by a dealer could result in a civil penalty of up to \$21,000 per vehicle. Correct all vehicles in your new vehicle inventory before delivery.

New! ATTACHMENTS

Attachment I: Administrative Information
Attachment II: Labor Allowances and Parts Ordering Information
Attachment III: Technical Information
Owner Notification Letters
Recall Reimbursement Plan

QUESTIONS & ASSISTANCE

For questions and assistance, contact the Special Service Support Center (SSSC) via the SSSC Web Contact Site. The SSSC Web Contact Site can be accessed through the Professional Technician Society (PTS) website using the SSSC link listed at the bottom of the OASIS VIN report screen or listed under the SSSC tab.

Sincerely,



Michael A. Berardi

DEMONSTRATION / DELIVERY HOLD - Safety Recall 16S30 - Supplement #6
Certain 2013-2015 Model Year C-MAX and Escape, 2012-2015 Focus,
2015 MKC and Mustang, and 2014-2016 Transit Connect Vehicles
Side Door Latch Replacement

OASIS ACTIVATION

OASIS was activated on August 26, 2016.

FSA VIN LISTS ACTIVATION

FSA VIN Lists were made available through <https://web.fsavinlists.dealerconnection.com> on August 26th, 2016. Owner names and addresses will be available when owner mailings have completed.

NOTE: Your FSA VIN Lists may contain owner names and addresses obtained from motor vehicle registration records. The use of such motor vehicle registration data for any purpose other than in connection with this recall is a violation of law in several states, provinces, and countries. Accordingly, you must limit the use of this listing to the follow-up necessary to complete this recall.

SOLD VEHICLES

- Owners of affected vehicles will be directed to dealers for repairs.
- Immediately contact any of your affected customers whose vehicles are not on your VIN list but are identified in OASIS. Give the customer a copy of the Owner Notification Letter (when available) and schedule a service date.
- Correct other affected vehicles identified in OASIS which are brought to your dealership.
- Dealers are to prioritize repairs of customer vehicles over repairs of new and used vehicle inventory.

STOCK VEHICLES

- Correct all affected units in your new vehicle inventory before delivery.
- Use OASIS to identify any affected vehicles in your used vehicle inventory.

DEALER-OPERATED RENTAL VEHICLES

A new law prohibits a Rental Company from selling, renting or leasing vehicles subject to a safety or compliance recall. This could impact dealer-operated rental fleets of 35 vehicles or more, including FRAC, LRAC, and DDR vehicles. Please see EFC04833 for details and consult your legal counsel for legal advice.

TITLE BRANDED / SALVAGED VEHICLES

Affected title branded and salvaged vehicles are eligible for this recall.

ADDITIONAL REPAIR (LABOR TIME AND/OR PARTS)

Additional repairs identified as necessary to complete the FSA should be managed as follows:

- For vehicles within new vehicle bumper-to-bumper warranty coverage, follow existing warranty and policy guidelines for related damage claims. No SSSC approval is required for these vehicles:
 - Ford vehicles – 3 years or 36,000 miles
 - Lincoln vehicles – 4 years or 50,000 miles
- For vehicles outside new vehicle bumper-to-bumper warranty coverage, dealers are pre-approved to claim up to \$100.00 in related damage.
 - For claims exceeding the pre-approved amount, submit an Approval Request to the SSSC Web Contact Site prior to completing the repair.

DEMONSTRATION / DELIVERY HOLD - Safety Recall 16S30 - Supplement #6

Certain 2013-2015 Model Year C-MAX and Escape, 2012-2015 Focus,
2015 MKC and Mustang, and 2014-2016 Transit Connect Vehicles
Side Door Latch Replacement

OWNER REFUNDS

- **This safety recall must be performed, even if the owner has paid for a previous repair. Claiming a refund will not close the recall on the vehicle.**
- Ford Motor Company is offering a refund for owner-paid repairs covered by this recall if the repair was performed prior to the date indicated in the reimbursement plan, which is posted with this bulletin. Owners are directed to seek reimbursement through authorized dealers or, at their option, directly through Ford Motor Company at P.O. Box 6251, Dearborn, MI 48121-6251.
- Dealers are also pre-approved to refund owner-paid emergency repairs that were performed away from an authorized servicing dealer after the end date specified in the reimbursement plan. Non-covered repairs, or those judged by Ford to be excessive, will not be reimbursed.
- Refunds will only be provided for the cost associated with side-door latch replacement.

RENTAL VEHICLES

Dealers are pre-approved for up to one day for a comparable rental vehicle. Follow Extended Service Plan (ESP) guidelines for dollar amounts. Rentals will only be reimbursed for the day(s) the vehicle is at the dealership for part replacement. Prior approval for more than one rental day is required from the SSSC via the SSSC Web Contact Site.

CLAIMS PREPARATION AND SUBMISSION

- Enter claims using Direct Warranty Entry (DWE) or One Warranty Solution (OWS).
 - DWE: refer to ACESII manual for claims preparation and submission information.
 - OWS: when entering claims in DMS software, select claim type 31: Field Service Action. The FSA number (16S30) is the sub code.
- Additional labor and/or parts must be claimed as related damage on a separate repair line from the FSA.
- For rental vehicle claiming, follow Extended Service Plan (ESP) guidelines for dollar amounts. Enter the total amount of the rental expense under Miscellaneous Expense code RENTAL.
- Submit refunds on a separate repair line.
 - Program Code: 16S30
 - Misc. Expense: ADMIN
 - Misc. Expense: REFUND
 - Misc. Expense: 0.2 Hrs.
- Multiple refunds should be submitted on one repair line and the invoice details for each repair should be detailed in the comments section of the claim.

NOTE: Parts will be replenished based upon paid claims, it is important for dealers to file and follow up on rejected claims in a timely manner.

DEMONSTRATION / DELIVERY HOLD - Safety Recall 16S30 - Supplement #6

Certain 2013-2015 Model Year C-MAX and Escape, 2012-2015 Focus,
2015 MKC and Mustang, and 2014-2016 Transit Connect Vehicles
Side Door Latch Replacement

LABOR ALLOWANCES

All claims with a repair date on or after August 1, 2017 must use updated labor times to reflect the updated service labor time standard process.

Description	Labor Operation	Labor Time
Replace both side door latches – Mustang	16S30L	1.3 Hours
Replace both sliding door latches – Transit Connect	16S30M	1.0 Hours
Replace all side door latches – C-MAX	16S30N	1.5 Hours
Replace all side door latches – Focus	16S30P	1.5 Hours
Replace all side door latches – Escape	16S30Q	1.4 Hours
Replace all side door latches – MKC	16S30R	1.5 Hours

The 5-minute video announcing Service Labor Time Standards (SLTS) development for Recalls and Technical Service Bulletins (TSBs) has been posted [here](#).

New! PARTS REQUIREMENTS / ORDERING INFORMATION

One kit contains all required latches for a vehicle repair. Only one kit should be claimed per VIN.

Part Number	Description	Order & Claiming Quantity
CJ5Z-54264A26-A	C-MAX / Escape / 2012-2014 Focus / MKC Door Latch Kit (contains 4 latches)	1
CJ5Z-54264A26-B	2015 Focus Door Latch Kit (contains 4 latches)	1
CJ5Z-54264A26-C	Mustang Door Latch Kit (contains 2 latches)	1
CJ5Z-54264A26-D	Transit Connect Door Latch Kit (contains 2 sliding door latches)	1

The DOR/COR number for this program is 51057.

As of August 24, 2017, all parts are now available through open ordering and the one-for-one replenishment plan has ended. The final one-for-one replenishment orders were submitted on August 23, 2017.

DEALER PRICE

For latest prices, refer to DOES II.

PARTS RETENTION AND RETURN

Follow the provisions of the Warranty and Policy Manual, Section 1 - WARRANTY PARTS RETENTION AND RETURN POLICIES.

EXCESS STOCK RETURN

Excess stock returned for credit must have been purchased from Ford Customer Service Division in accordance with Policy Procedure Bulletin 4000.



CERTAIN 2013-2015 MODEL YEAR C-MAX AND ESCAPE, 2012-2015 FOCUS, 2015 MKC AND MUSTANG, AND 2014-2016 TRANSIT CONNECT VEHICLES - SIDE DOOR LATCH REPLACEMENT

OVERVIEW

In the affected vehicles, the pawl spring tab in a side door latch may break, which may make the door difficult to latch. A door that opens while driving increases the risk of injury. Before demonstrating or delivering any new in-stock vehicles, dealers are to replace the following door latches:

- C-MAX, Escape, Focus, MKC - all four side door latches.
- Mustang - two side door latches.
- Transit Connect - two sliding door latches.

SERVICE PROCEDURE

NOTE: Videos demonstrating the complete repairs on Focus and Escape vehicles can be found below.
Focus  Escape 

Recommended Tool List:

1/4" Drive Sockets 5.5mm, 7mm, 10mm (Combination of Long and Short)
1/4" Drive Torx Bits T-20, T-25, T27, T-30, T35 (Combination of Long and Short)
1/4" Drive Extension 3 in (76 mm) to 6 in (152 mm)
1/4" Drive Cordless Impact Driver
1/4" Ratchet
1/4" Torque Wrench
Needle Nose Pliers
Plastic Trim Tools
Small Flathead Pocket Screwdriver
Large Flathead Screwdriver
Flash Light
Telescoping Magnet
Straight and Curved Pick
Long Reach Trim Pry Tool 15 in (381 mm)



IMPORTANT: If equipped, ensure that the blocking lever and blocking lever spring are transferred to the *new* door latch, along with all other components removed from the old door latch.
See Figure 1.



FIGURE 1

TABLE OF CONTENTS

C-MAX and Focus.....	Page 3
Escape and MKC	Page 3
Transit Connect	Page 4
Mustang.....	Page 8



C-MAX and Focus Vehicles

NOTE: For front door latch replacement, it is not necessary to remove the door modules, speakers, or water shield. To access components for removal, position aside the water shield as needed. See Figure 2.

1. Replace the front and rear side door latches. Please follow the Workshop Manual (WSM) procedures in Section 501-14.



FIGURE 2

Escape and MKC Vehicles

NOTE: For front door latch replacement, it is not necessary to completely remove the window regulator. Remove the two bolts and position aside the outer portion of the window regulator. See Figure 3.

1. Replace the front and rear side door latches. Please follow the WSM procedures in Section 501-14.

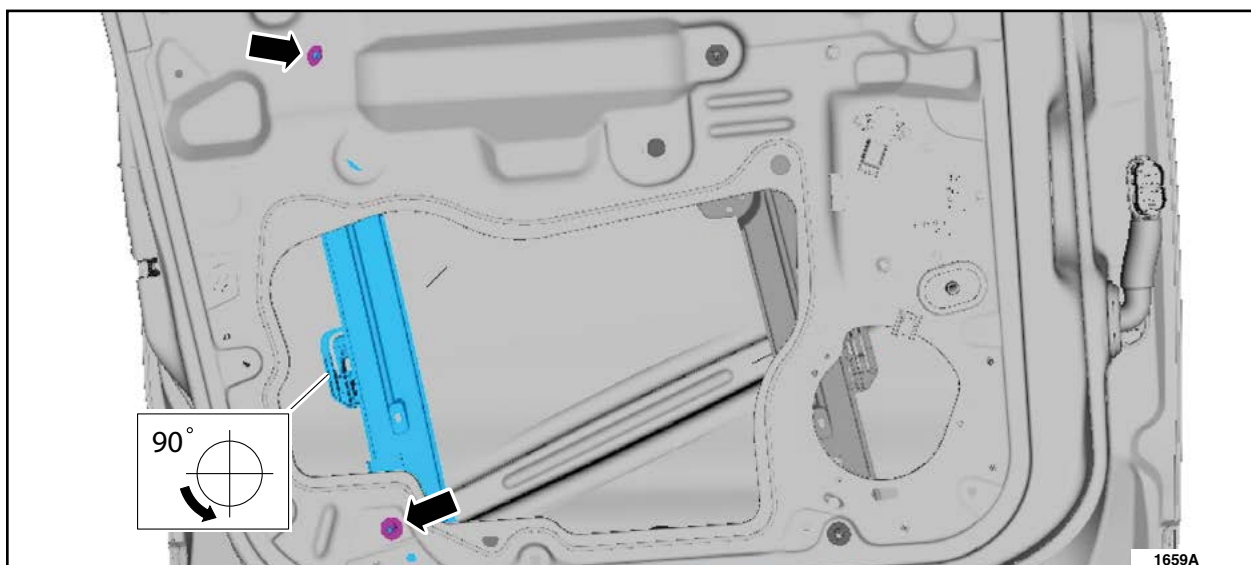

FIGURE 3



Transit Connect Vehicles

NOTE: Only the RH and LH sliding door latches are affected on Transit Connect Vehicles.

1. Remove the sliding door trim panel. Please follow the WSM procedures in Section 501-05.
2. Raise the sliding door glass to the full up position. See Figure 4.

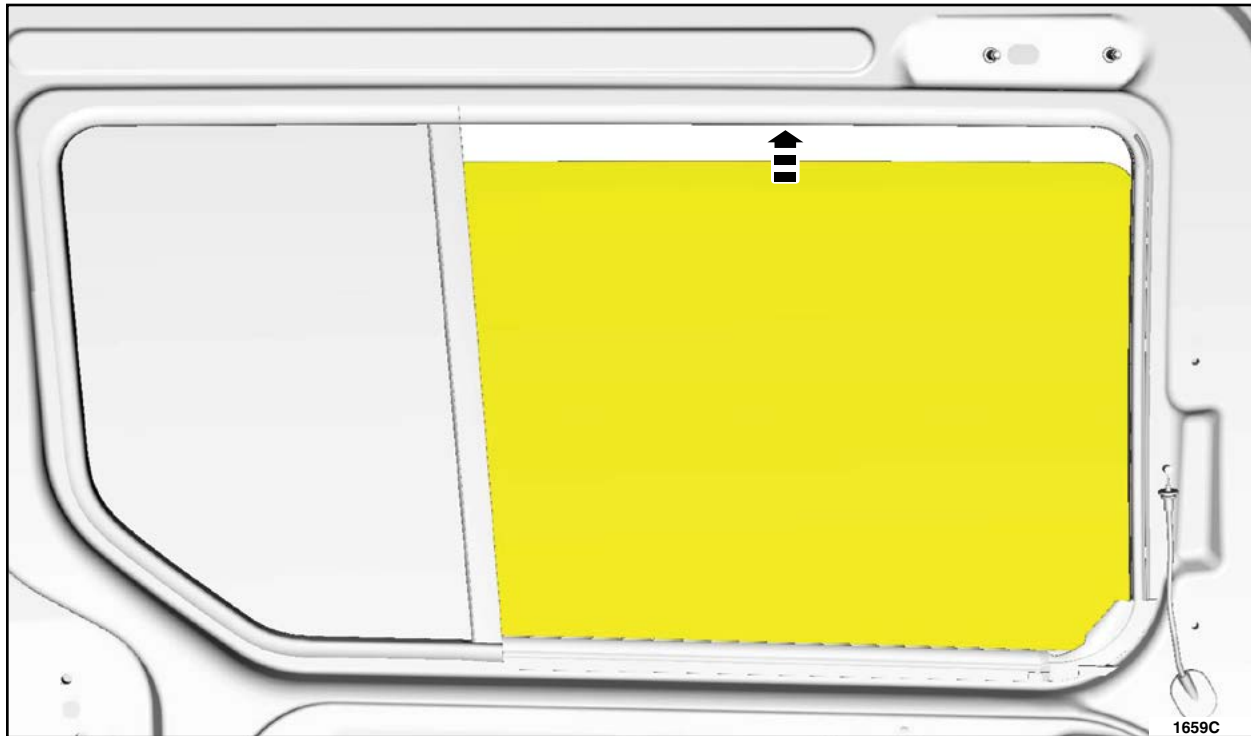

FIGURE 4



3. Remove the sliding door watershield using an interior trim remover tool. See Figure 5.

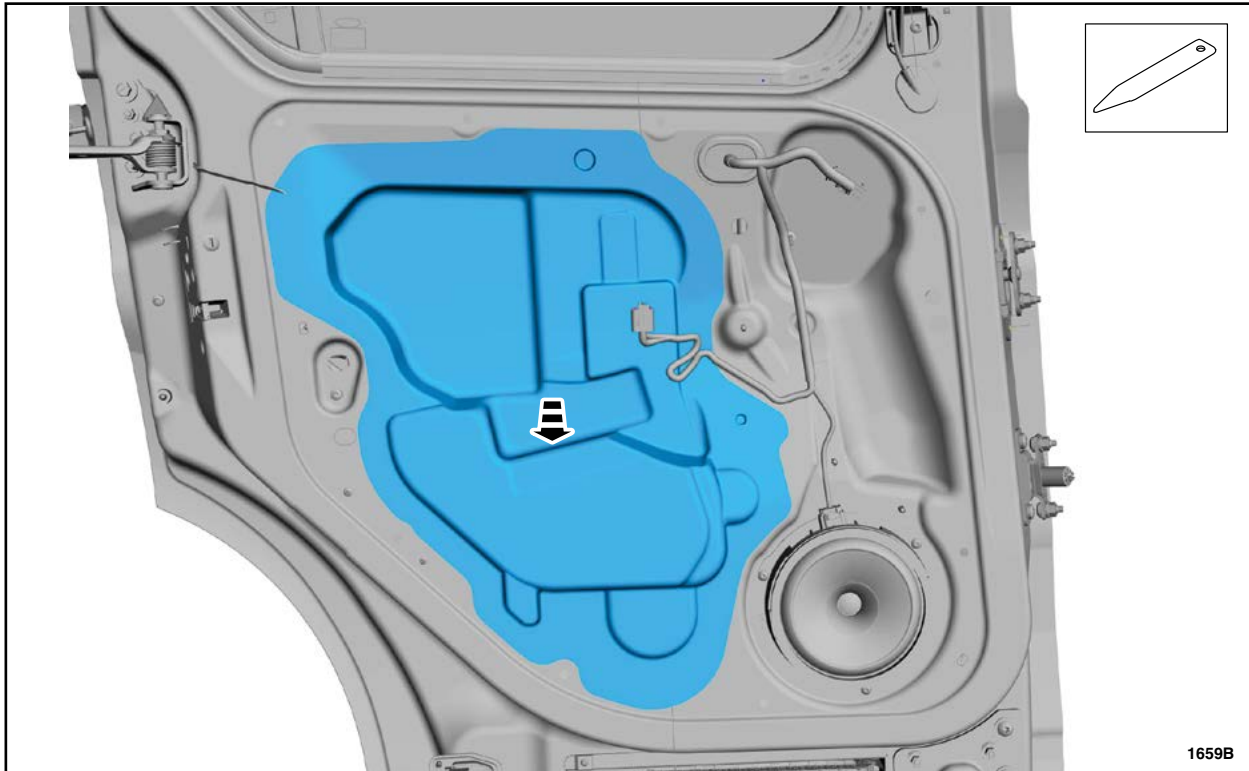

FIGURE 5

4. Remove the sliding door latch bolts. See Figure 6.

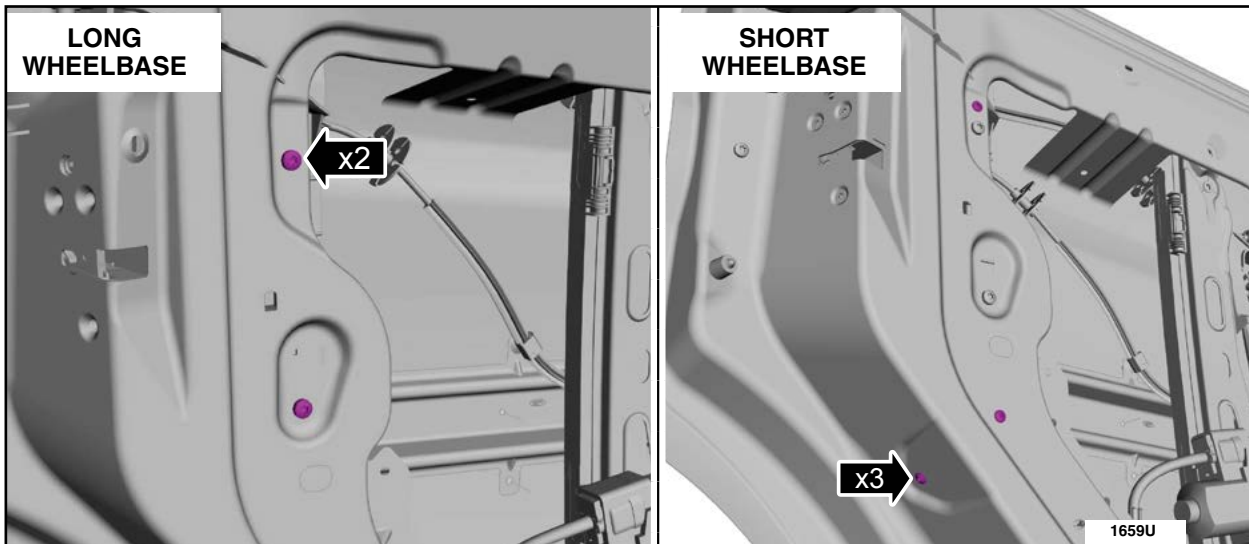

FIGURE 6



5. Remove the sliding door latch bolts. See Figure 7.

- Torque: 106 lb.in (12 Nm).

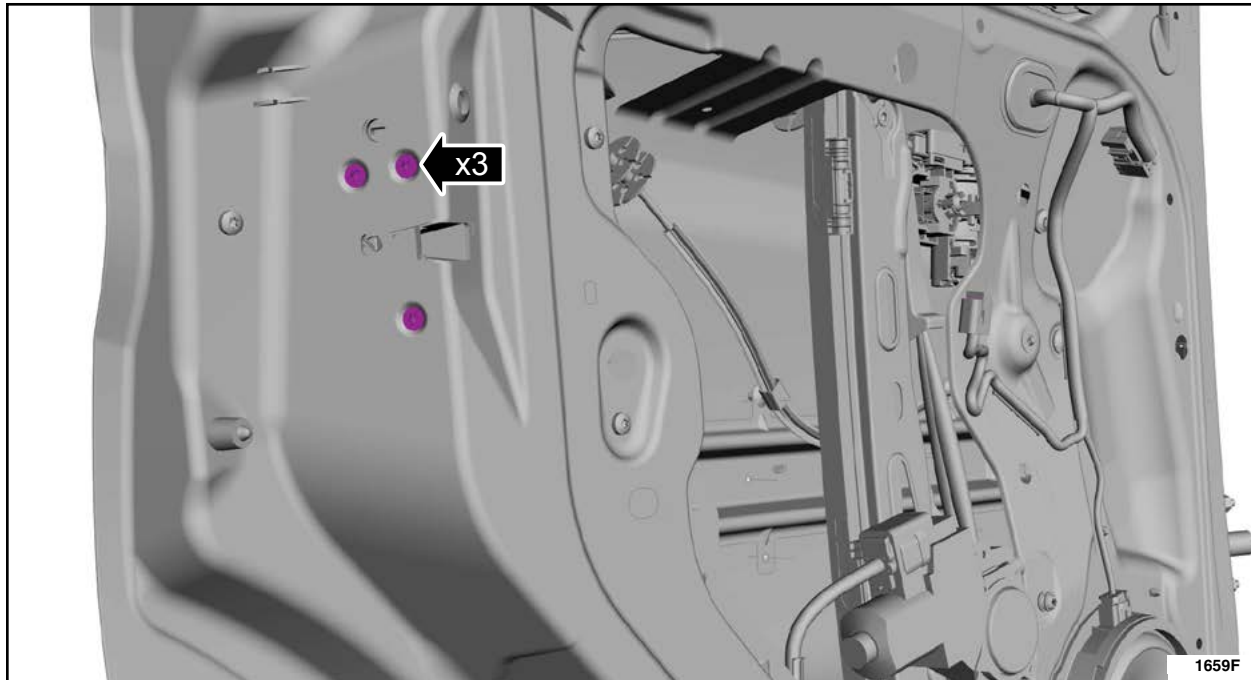

FIGURE 7

6. Disconnect the electrical connector from the sliding door latch. See Figure 8.

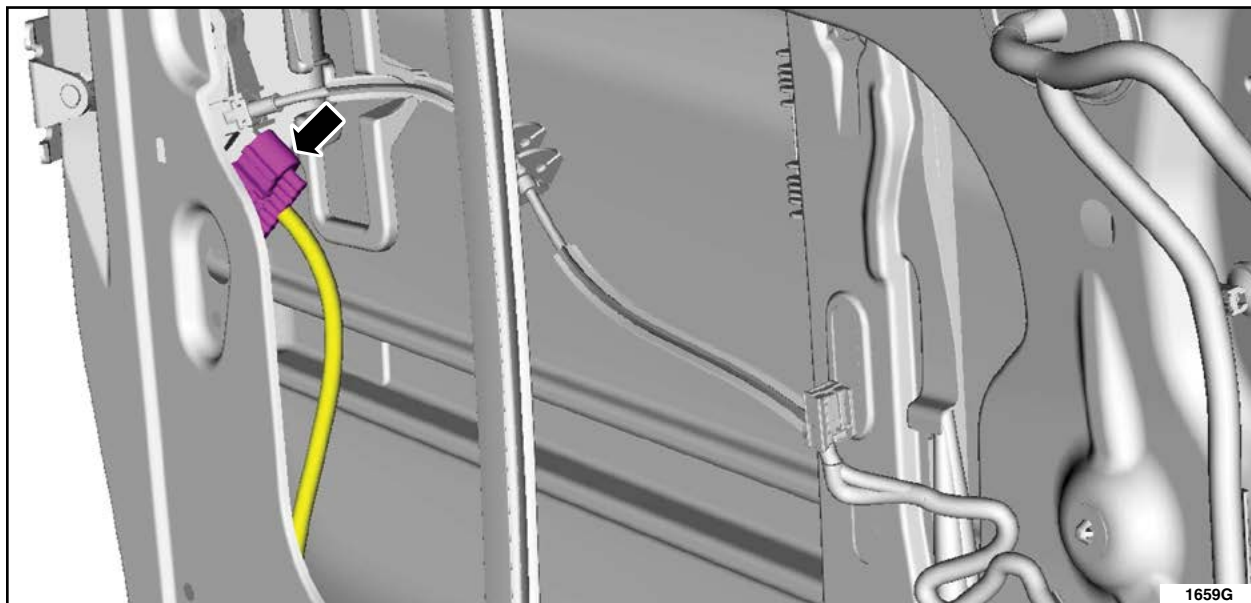

FIGURE 8



7. Position the sliding door latch out of the sliding door. See Figure 9.



FIGURE 9

8. Disconnect the interior and exterior sliding door latch cables. Remove and discard the sliding door latch. See Figure 10.

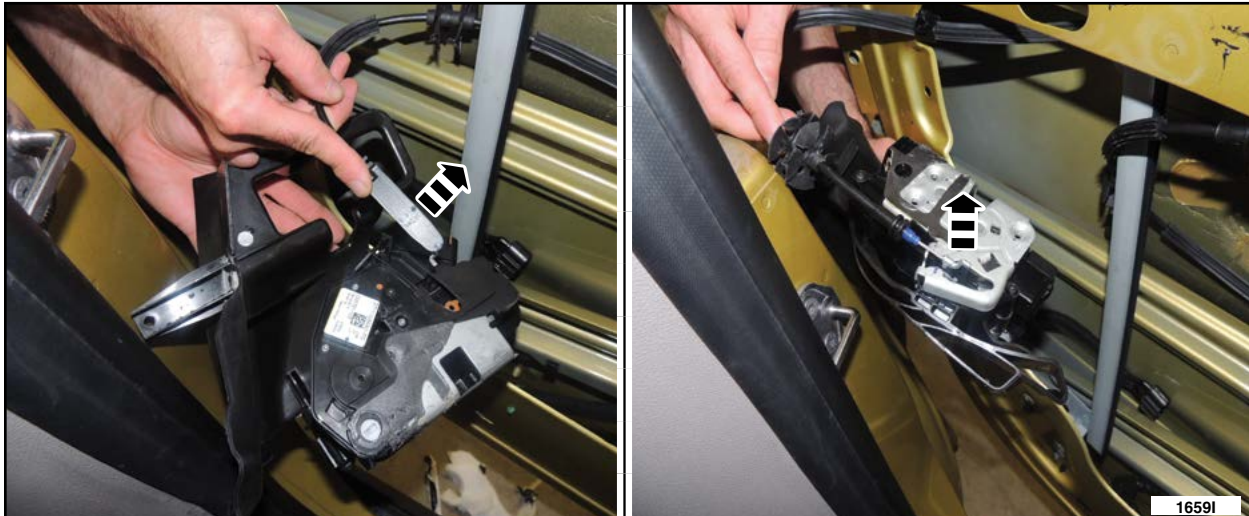

FIGURE 10

NOTE: When installing the *new* sliding door latches, align the child lock actuator with the slot in the sliding door before installing the sliding door latch bolts.

9. To install *new* sliding door latches, reverse the removal procedure.



Mustang Vehicles

NOTE: Use this procedure to service the side door latches.

1. Remove the front door trim panel. Please follow the WSM procedures in Section 501-05.
2. Align and apply masking tape or equivalent to window glass fore and aft along window seals as reference points for alignment during re-installation of the window glass. See Figure 11.

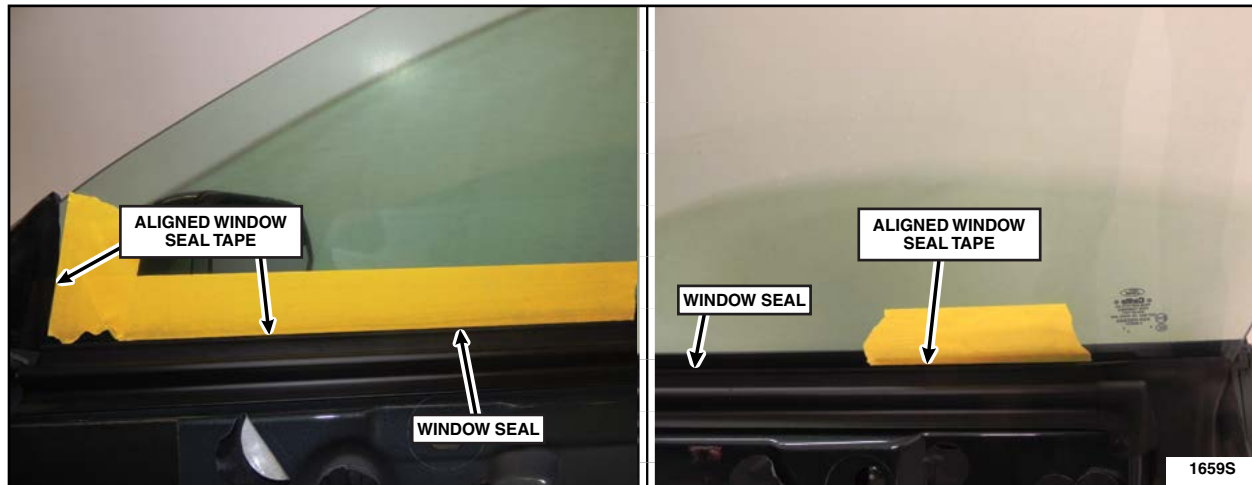

FIGURE 11

NOTE: BEFORE removing the fasteners, mark all of the fasteners for the aft front door glass run and front door window regulator with a paint pen or permanent marker. See Figure 12.

3. Replace both side door latches. Please follow the WSM procedures in Section 501-14.



FIGURE 12

NOTE: When reinstalling the window glass, align the tape with the window seal to ensure proper fit before tightening the fasteners. Door window glass adjustment is not necessary when following this procedure. See Figure 11.

