

CERTAIN 2017 MODEL YEAR FUSION TITANIUM, PLATINUM, SPORT, SE WITH LUXURY PACKAGE, AND ENERGI VEHICLES — HEADLAMP ASSEMBLY REPLACEMENT

OVERVIEW

All of the affected vehicles are equipped with LED headlamps which may exhibit dim daytime running lamp appearance after a short time of normal usage. Dealers are to replace both headlamp assemblies.

SERVICE PROCEDURE

1. Remove both front wheel and tire assemblies. Please follow the Workshop Manual (WSM) procedures in Section 204-04A.
2. Remove the five plastic rivets from the front of both front fender liners. See Figure 1.

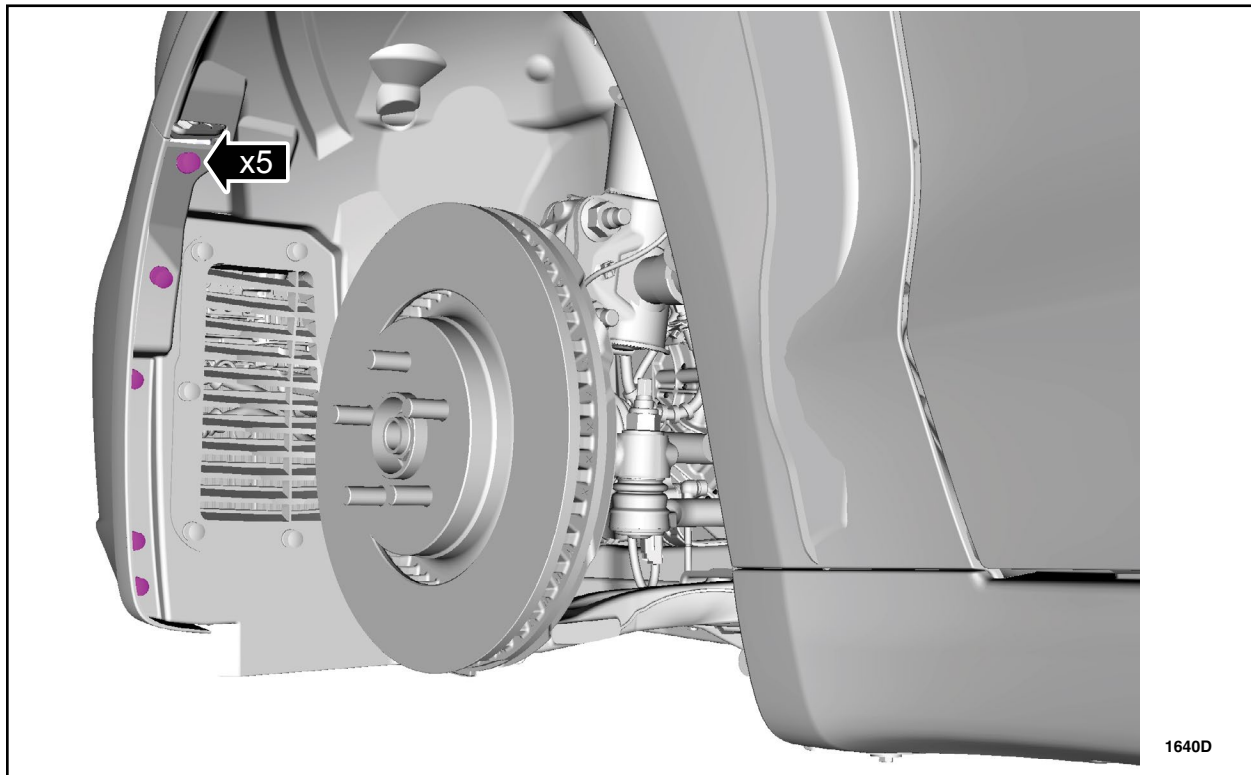

FIGURE 1



3. Remove the twelve front bumper cover-to-lower radiator closeout screws as shown in Figure 2.

- **Do not** remove the two center screws.

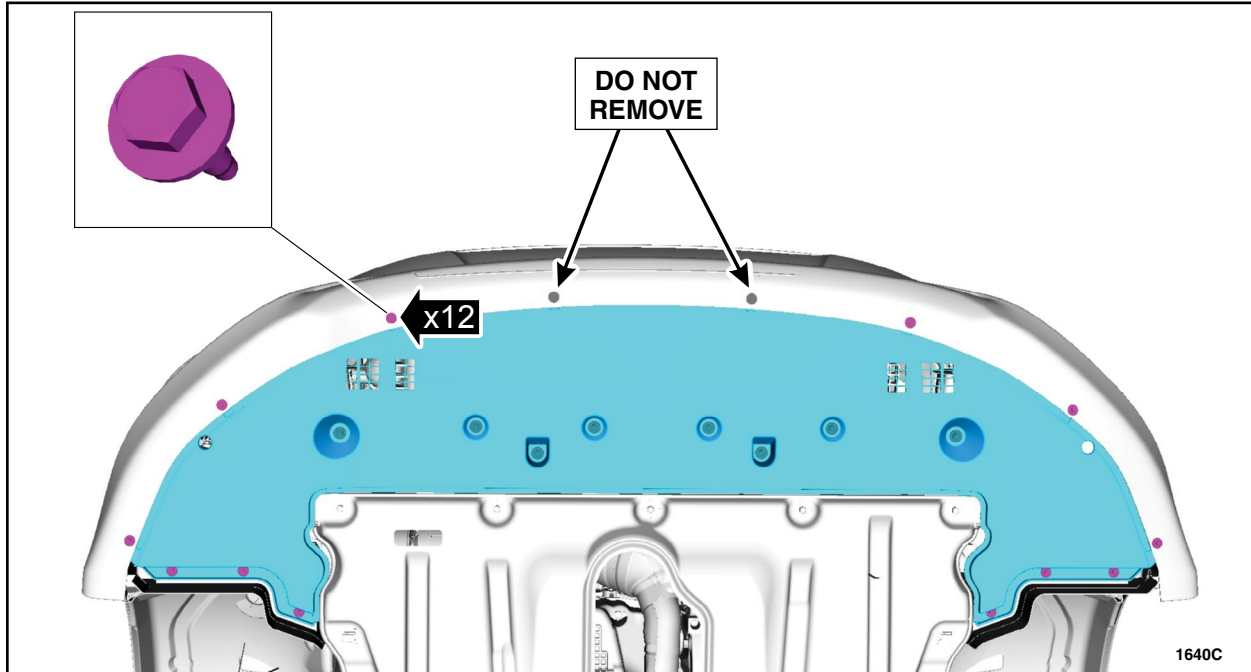

FIGURE 2

4. Remove the two nuts and position both front fender liners aside. See Figure 3.

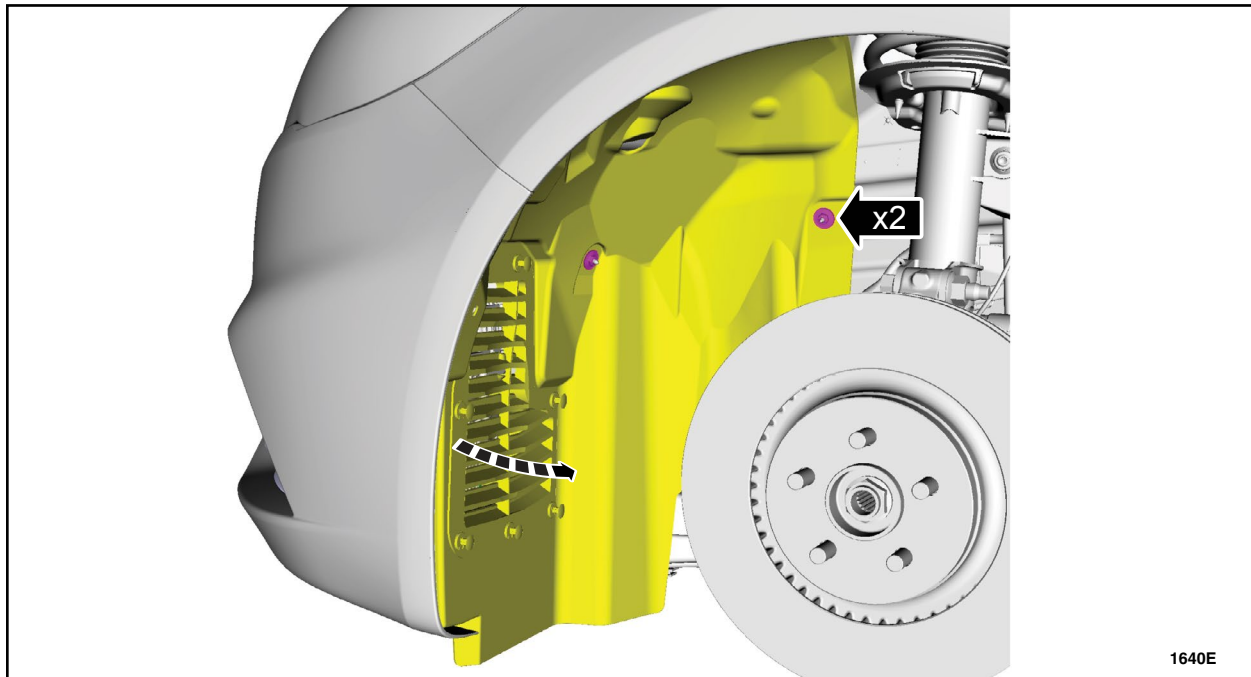

FIGURE 3



5. Remove the two front bumper cover-to-fender bolts on both sides of the vehicle. See Figure 4.

- To install, tighten to 55 lb.in (6.2 Nm).

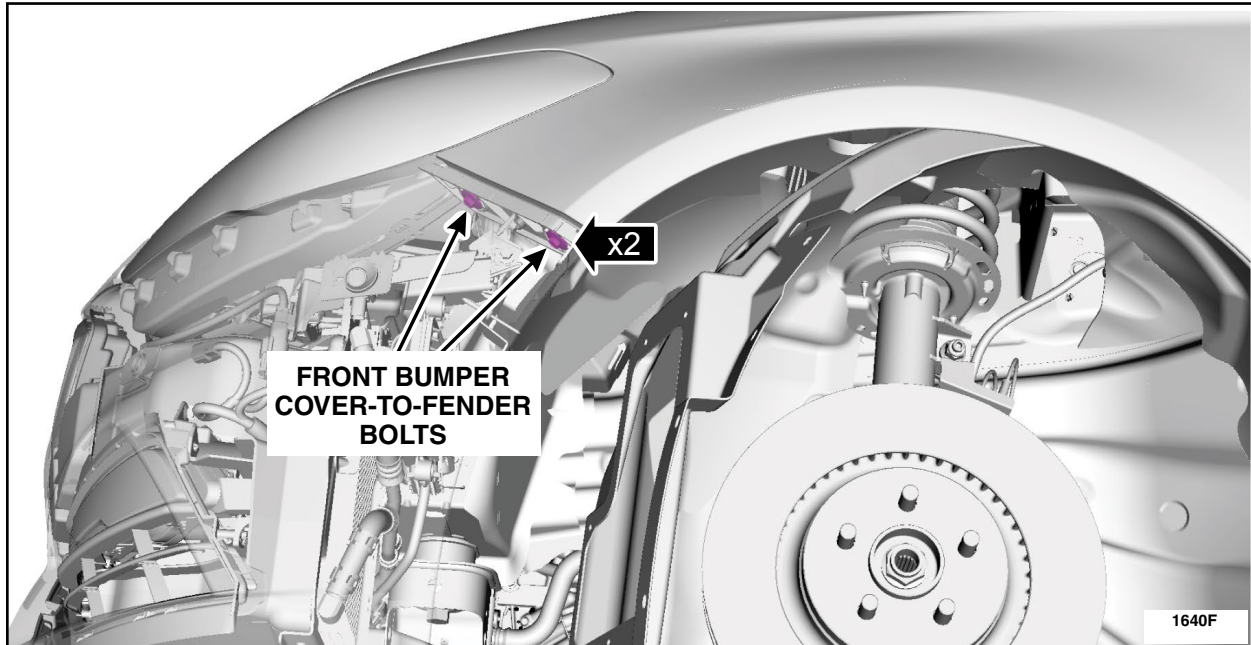

FIGURE 4

6. Remove the five upper front bumper cover bolts and four pin-type retainers. See Figure 5.

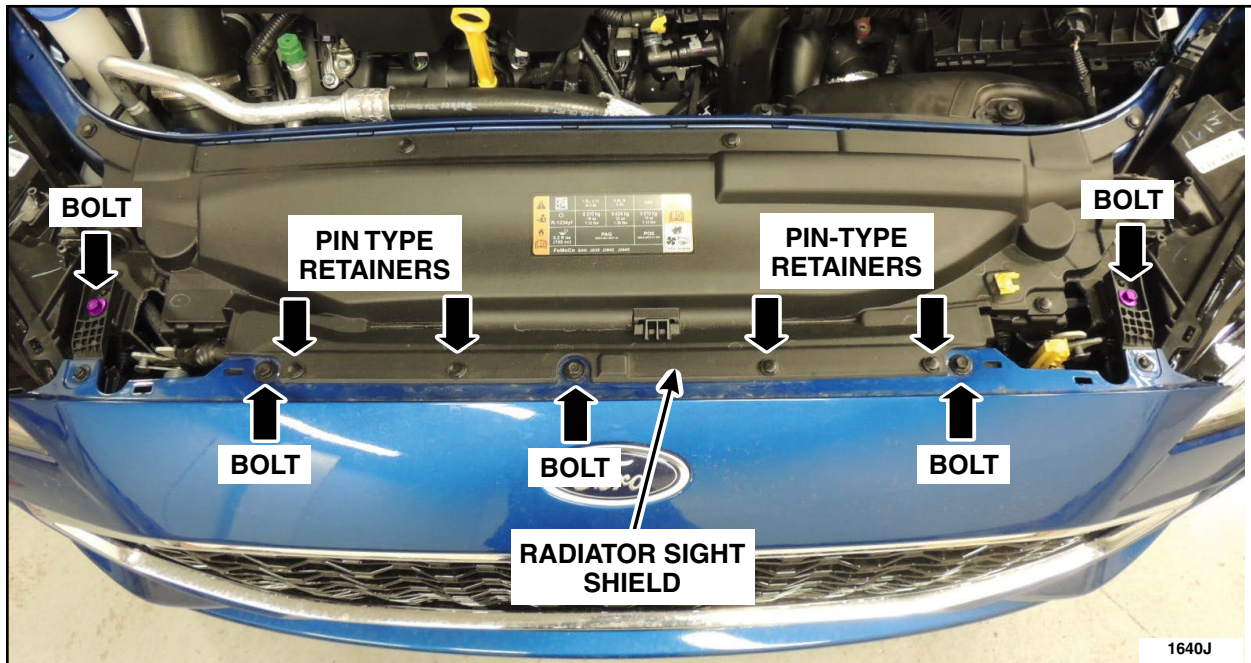

FIGURE 5



7. Position the bumper cover forward. See Figure 6.



FIGURE 6

8. Remove the headlamp bolt, two screws and disconnect the headlamp electrical connector from both headlamps. See Figure 7.

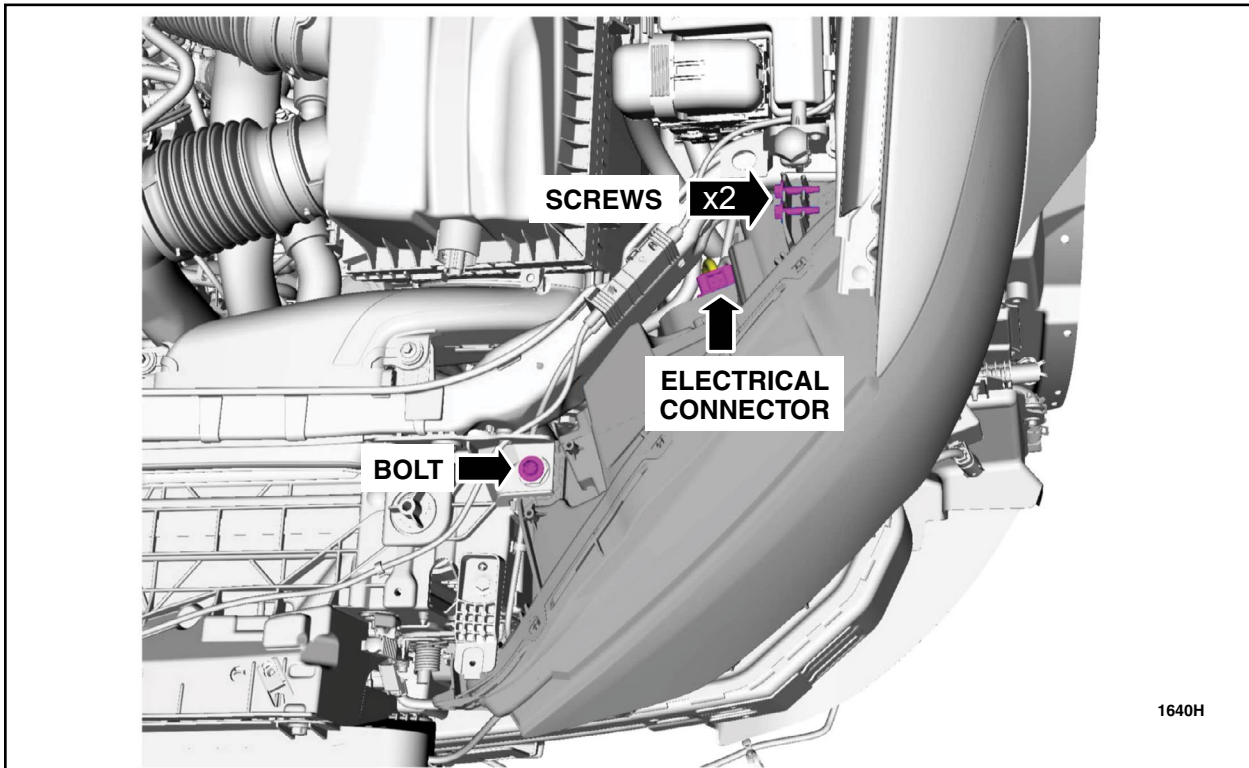

FIGURE 7



9. Remove both headlamp assemblies (See Figure 8):
 - a. Separate the headlamp assembly from the ball stud.
 - b. If equipped, separate the two wire harness guides from the headlamp assembly.

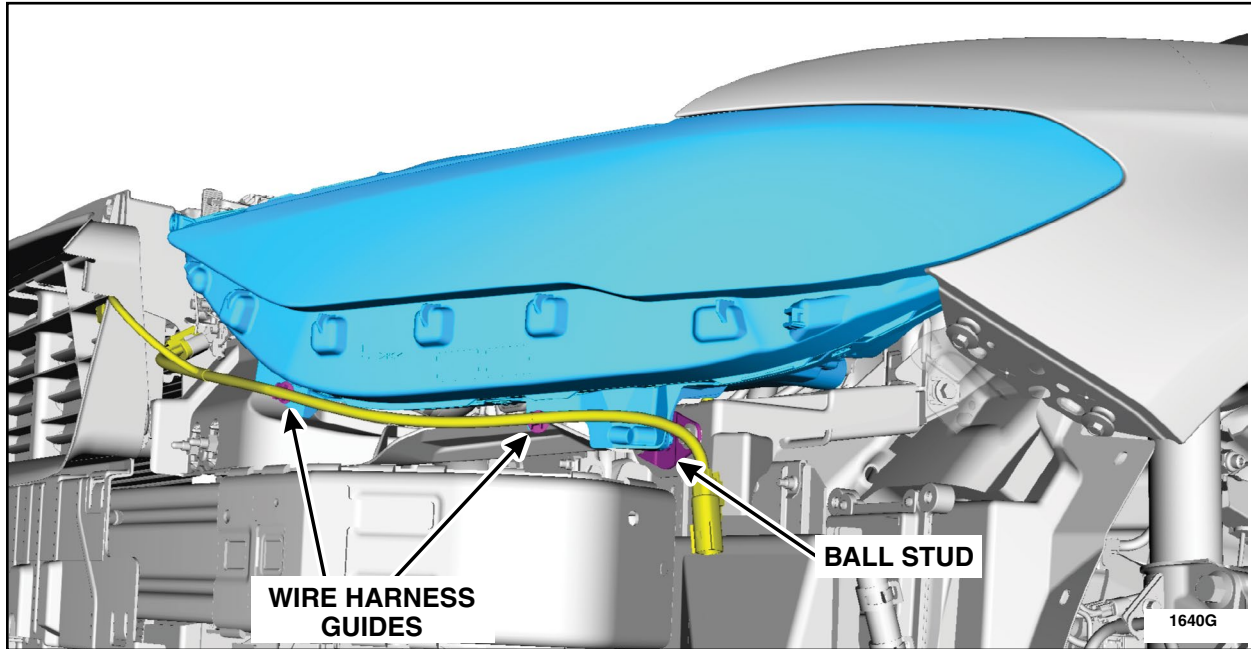

FIGURE 8

10. Transfer the LED control module from the old headlamps to the *new* headlamps. See Figure 9.

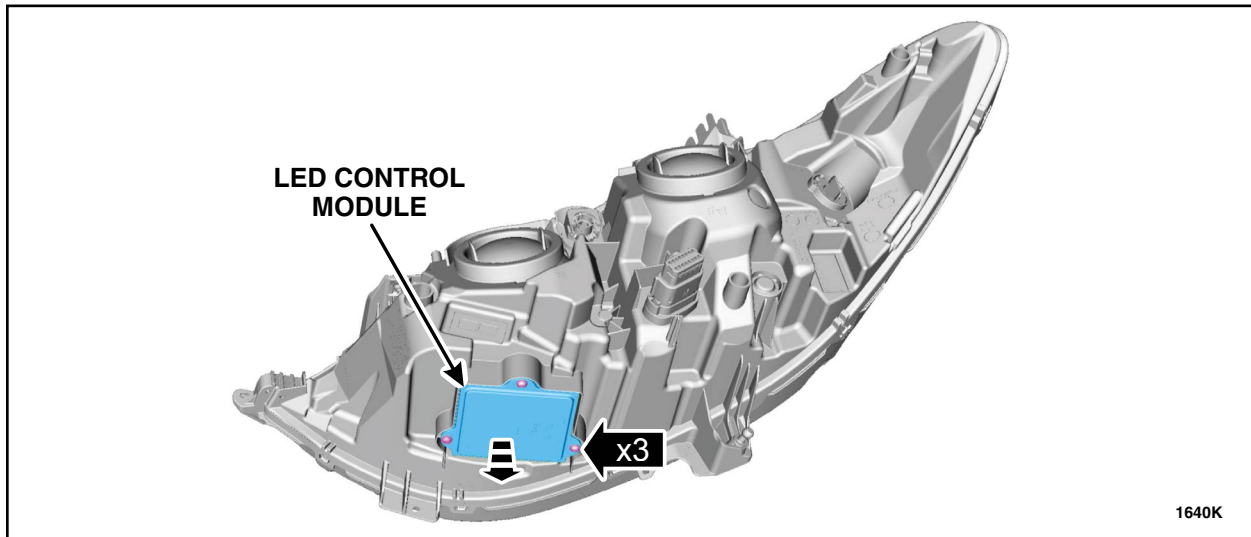

FIGURE 9

11. Install both headlamp assemblies onto the ball stud (See Figure 8):
 - a. If equipped, install the wiring harness guides to the headlamp assemblies. See Figure 8.
 - b. Install the headlamp bolt finger tight. See Figure 7.
 - c. Install the headlamp screws finger tight. See Figure 7.
 - d. Connect the headlamp electrical connector. See Figure 7.
 - e. Verify correct headlamp electrical operation.



12. Align the headlamp assemblies to the fender openings. See Figure 10.

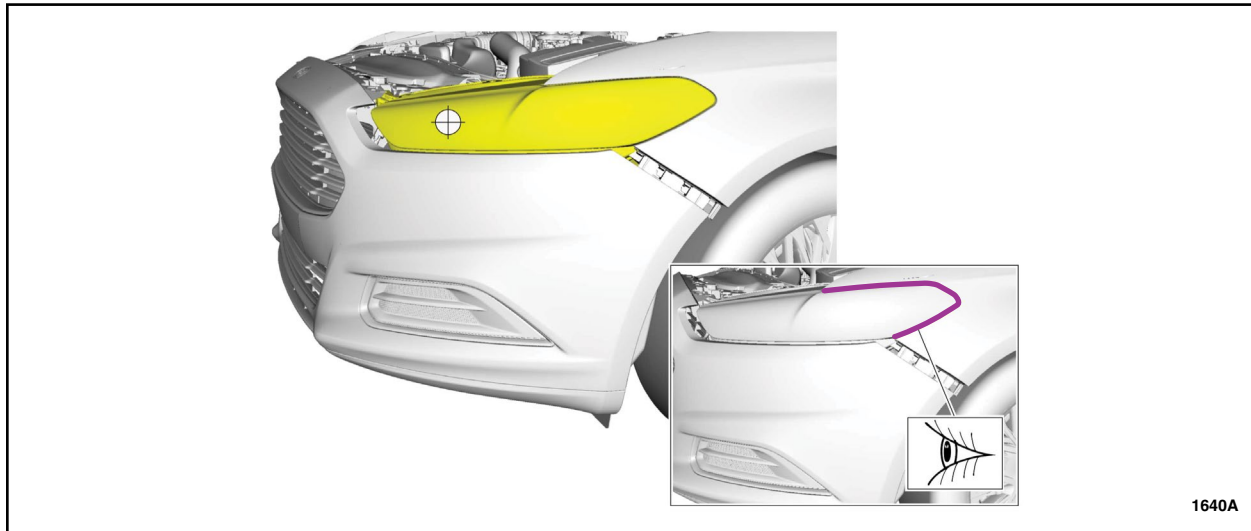

FIGURE 10

13. Tighten the bolt and screws for each headlamp assembly to 32 lb.in (3.6 Nm). See Figure 11.

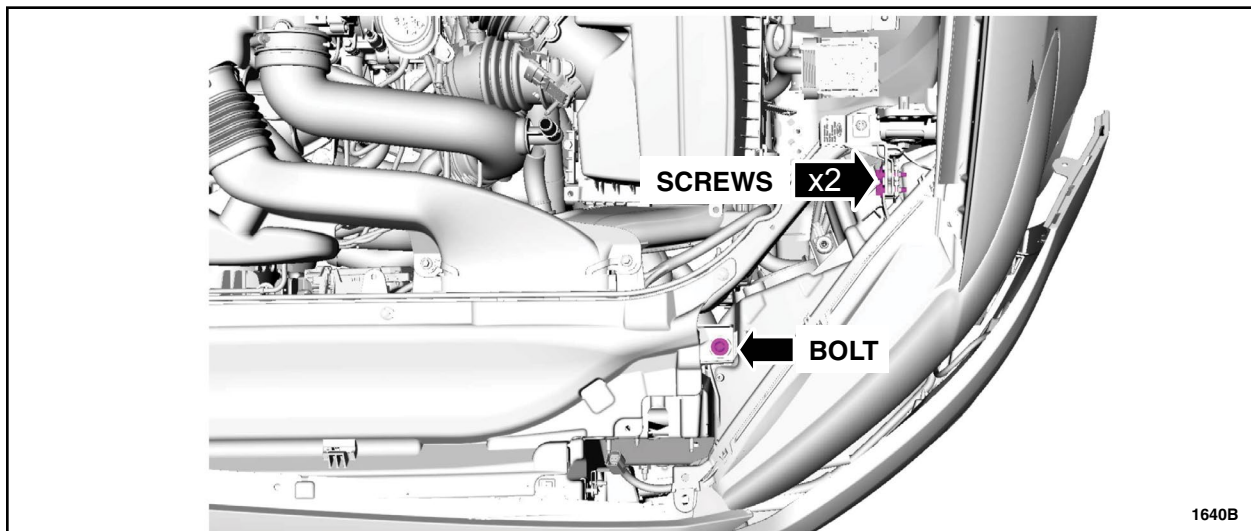

FIGURE 11

14. Reposition the bumper cover. See Figure 6.

- Make sure the bumper cover is positioned under the radiator sight shield. See Figure 5.

15. Reverse the removal procedure to complete the headlamp replacement.

16. Check headlamp adjustment on both headlamps. Please follow the WSM procedure in Section 417-01, General Procedures.

