



Bulletin No.: 14525-15036
Updated: May 2016

PRODUCT SAFETY RECALL

SUBJECT: Front Passenger Air Bag Inflator Replacement

MODELS: 2005 Saab 9-2X

UPDATE – May 2016: New and different inflators are available for affected 2005 Saab 9-2X vehicles. As a result there are different installation instructions depending on the inflator being installed. Please refer to the appropriate service procedure instructions and parts information which were updated to reflect the new parts.

CONDITION

Subaru of America has decided that a defect, which relates to motor vehicle safety, exists in certain 2005 model year Saab 9-2X vehicles currently registered or previously registered in Florida, Hawaii, Puerto Rico or U.S. Virgin Islands. These vehicles were manufactured by Subaru of America and marketed by General Motors. As a result, GM is conducting a safety recall.

These vehicles are equipped with front passenger air bag assemblies. When operated in areas with consistently high absolute humidity, the front passenger air bag inflator module could be susceptible to rupture and the front passenger air bag could deploy abnormally in a crash, increasing the risk of injury to the occupant.

CORRECTION

Saab Official Service Centers (OSCs) are to replace the front passenger air bag inflator module.

VEHICLES INVOLVED

All affected Saab 9-2X vehicles are identified by Vehicle Identification in the Orio Inquiry by Chassis screen. OSC service personnel should always check this site to confirm vehicle involvement prior to beginning any required inspections and/or repairs. It is important to routinely use this tool to verify eligibility because not all similar vehicles may be involved regardless of description or option content.



OWNER NOTIFICATION

Notification letters were sent to owners of all potentially affected vehicles.

PART INFORMATION

Parts are to be ordered through the normal parts order process. There will be no pre-shipment of parts. New and different inflators are available for affected Saab 9-2X vehicles. You may receive a different part number than ordered, and the inflator may physically look different from previous replacement parts. As a result, there are different installation instructions depending on which part number is being installed. The parts information listed below and the service procedure information were updated to reflect the new parts.

Saab Part Number	Description	Quantity-Vehicle
98279FE00 Or 98279FE07	INFLATOR ASM, I-P MDL AIR BAG *	1

*** Note to all Dealers:** Do not discard or destroy the box containing the new passenger air bag inflator module, it will be needed to return the used inflator module. The box contains special instructions for the packaging and shipment of the used inflator. The instructions must be followed without exception. **DO NOT DEPLOY ANY INFLATOR.**

PART RETURN PROCEDURES – U.S (48 States).

Each removed air bag inflator must be returned directly to the supplier, Takata USA.

Refer to the instructions included with the new inflator module. The used inflator modules must be returned Every 90 days or upon accumulation 200 kits.

- The shipping box contains a bar code label, which will be used by Takata USA to document the replacement of the old inflator with the new inflator. **Therefore, it is very important that the removed inflator be returned in the exact same box that contained the newly-installed inflator for that vehicle.** If the original box cannot be re-used, please refer to the shipping instructions under “Requesting a new box/shipping labels.”
- **IMPORTANT:** When affixing the shipping label to the shipping box do not obstruct the bar code label.

PART RETURN PROCEDURES – CANADA

Disregard the instructions and shipping forms included with the new inflator module. These instructions/forms are intended for US dealers only! Canadian dealers must refer to the instructions provided at the end of this bulletin!

- The shipping box contains a bar code label, which will be used by Takata USA to document the replacement of the old inflator with the new inflator. **Therefore, it is very important that the removed inflator be returned in the exact same box that contained the newly-installed inflator for that vehicle.** If the original box cannot be re-used, please refer to the shipping instructions under “Requesting a new box/shipping labels.”
- **IMPORTANT:** When sealing the shipping box do not obstruct the bar code label.
- A copy of the Repair Order must be included with the returned inflator. The Repair Order must contain the following information: claim number, repair date, full 17-digit VIN, and mileage.

SPECIAL TOOLS

The air bag mounting bracket, shown below, is required to perform the front passenger air bag inflator module replacement procedure described in this bulletin. A bracket will be sent to each Saab Official Service Center (OSC). These brackets are being provided at no charge. The first bracket is provided at no charge, however, there is a charge for any additional brackets.

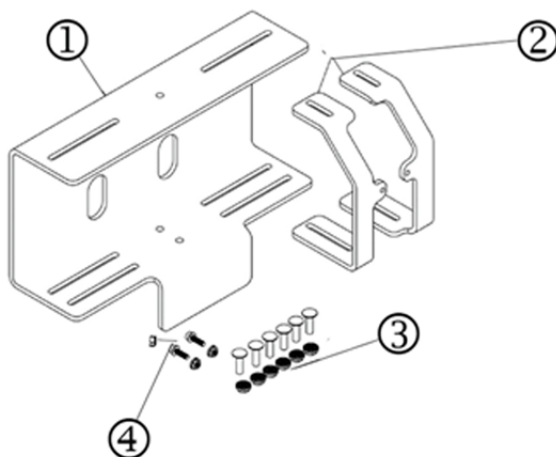

4006668

(1) Mounting Bracket (2) Support Bars (3) Support Bar Hardware (4) Air bag Mounting Hardware.



SERVICE PROCEDURE P/N 98279FE00

Note: Saab Official Service Centers are required to use the air bag mounting bracket to perform the front passenger air bag inflator module replacement procedure. If the air bag mounting bracket is not available, do not proceed with this repair.

Note: All involved vehicles are identified by Vehicle Identification Number on the Orio “Inquiry By Chassis” screen. Saab Official Service Center personnel should always check this site to confirm vehicle involvement prior to beginning any required inspections and-or repairs. It is important to routinely use this tool to verify eligibility because not all similar vehicles may be involved regardless of description or option content.

Note: This recall bulletin provides service repair and Labor time information for replacing the passenger side air bag inflator module. Other repairs, if required, are to be billed under warranty, goodwill assistance or customer pay.

1. Connect the scan tool and determine if any diagnostic trouble codes (DTCs) have been set. Record set DTCs, if present, on the Repair Order.
2. Remove the instrument panel (I-P) compartment. Refer to *Instrument Panel Compartment Replacement* in WIS.
3. Disconnect cable from negative battery terminal. Refer to *Battery Negative Cable Disconnection and Connection* in WIS.

Danger: Wait at least 90 seconds after disconnecting the cable from the negative battery terminal to prevent air bag and seat belt pretensioner deployment.

Caution: Avoid scratching or damaging the dashboard assembly. Place protective tape on the dashboard if needed.

4. Remove the instrument panel passenger air bag assembly. Refer to *Air bag Instrument Panel Module Replacement* in WIS.

Safety Precautions

Warning: If an air bag system is not handled using proper procedures and methods, it may be activated accidentally during work resulting in a life-threatening serious accident. If the service procedure is NOT performed correctly, the system may fail to activate when needed. Be sure to perform the proper work safely and according to the instructions in this service procedure.

1. **Eliminate Static Electricity.** Before start of work, touch a metallic portion of the vehicle with a bare hand to discharge static electricity charged on your body.
2. **DO NOT Measure Resistance.** DO NOT measure resistance of air bag components. Measuring current of a circuit tester may cause accidental activation.



3. **Handle The Air Bag Properly.** If an inflator is dropped, replace it with a **NEW** inflator.
4. **DO NOT Allow Foreign Objects Near Air bag.** Collect and account for all removed nuts-bolts to prevent them from landing in the air bag assembly. Any foreign objects in the air bag assembly may cause damage or injury if the air bag is activated.
5. **Wear Protective Equipment.** Always wear appropriate protective equipment when working on the air bag.

Front Passenger Air bag Inflator Module Replacement

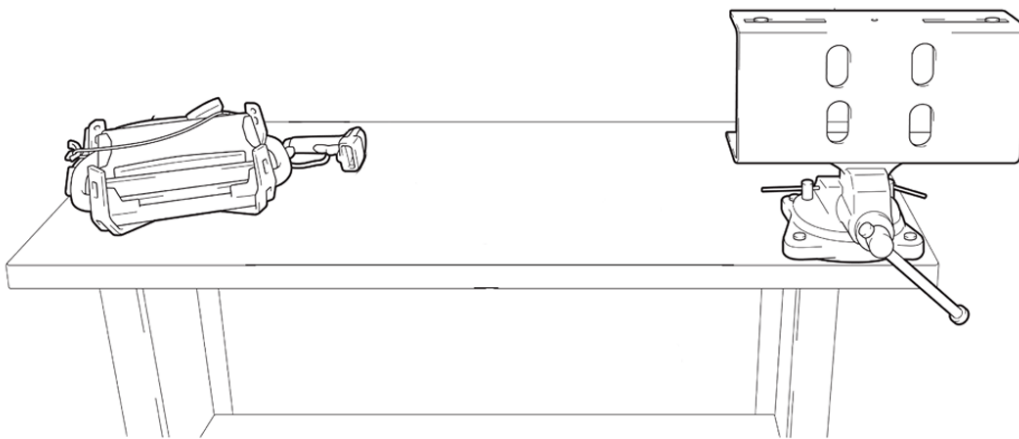

3607819

Danger: To avoid personal injury or death, it is critical to use an air bag module bracket when replacing an inflator module. Carefully read and follow the instructions below:

- Confirm the bracket assembly is installed securely in the vice.
 - Confirm there are no loose objects or people exposed to the back side of the bracket for safety in the unlikely event of air bag deployment due to improper work procedures. The air bag is NOT being replaced due to an inadvertent deployment concern.
 - Confirm that no objects, tools or people are within 3 feet (1 meter) of the back side of the bracket.
 - Confirm that no objects, tools or people are within 2 feet (0.6 meters) of the sides of the bracket.
 - BEFORE starting work and periodically while working on the air bag module, touch a metallic part of the work bench to discharge static electricity in the body.
1. Mount the bracket securely in a vice assembled as seen below. Note the position of the brackets and the orientation of the bolt heads.

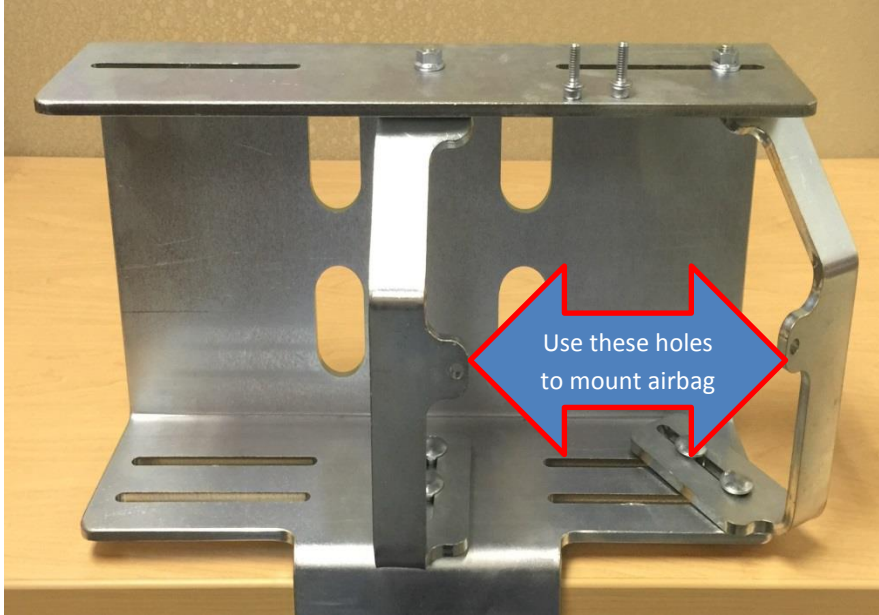

2. Position the airbag assembly into the holes on the bracket support bars. Use the 2 Allen head bolts supplied with bracket. Once the airbag is in position tighten all of the mounting bracket bolts.

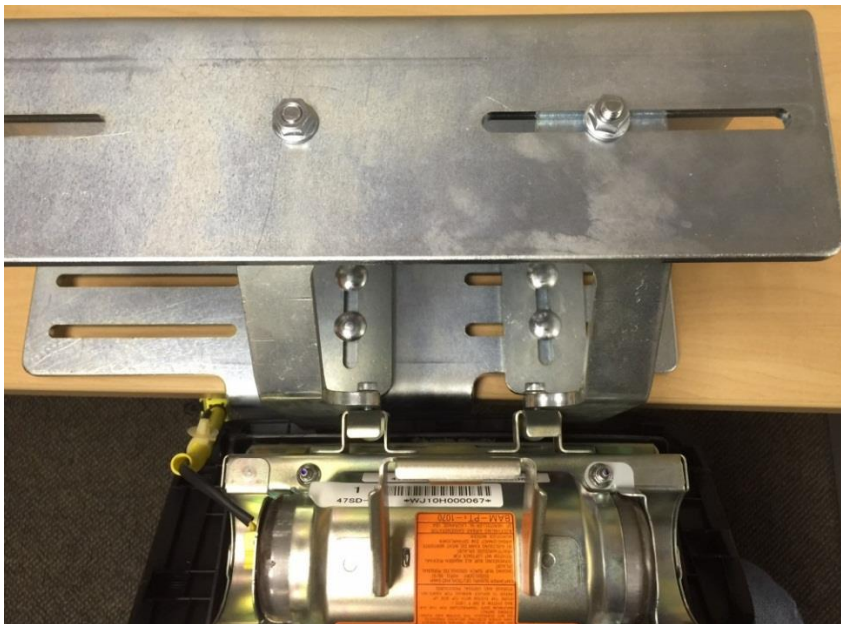

3. Next tighten the 2 Allen bolts (from the kit) holding the air bag to the support bars.
4. Confirm the following steps have been completed BEFORE proceeding to the next step:
 - The bracket is secure in the vise and the airbag is facing away from you.
 - The air bag module is secured to the support bars of the bracket.



- The support bars are secured on the mounting bracket using one (1) bolt-nut at the top of each support bar and two (2) nuts-bolts at the bottom of each support bar.

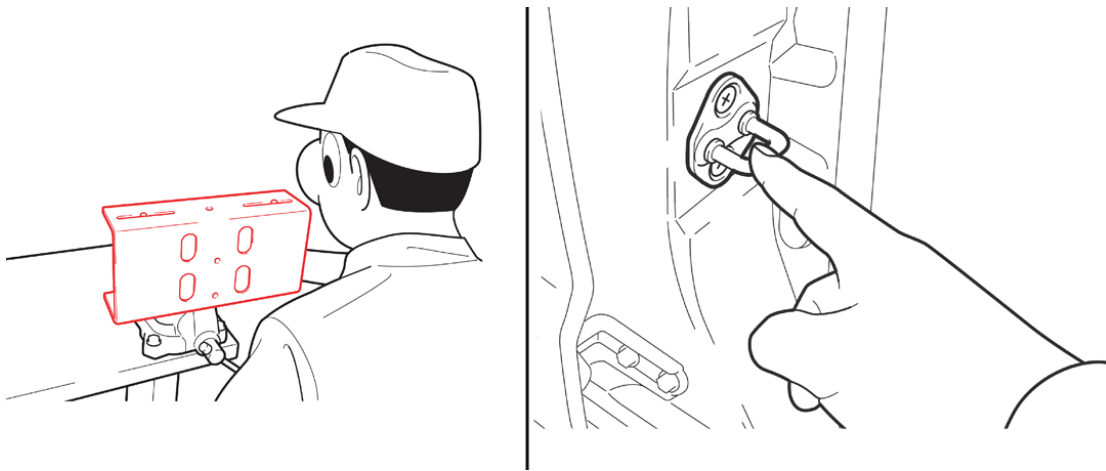

3607909

Danger: To avoid personal injury, *ALWAYS* keep as much of your body as possible in front of the bracket when working on the air bag assembly. Remember to periodically touch a metallic part of the vehicle or work bench to discharge static electricity in the body.

The Airbag should be mounted in the bracket as seen below with the bracket clamped securely in a table mounted vise as shown in the line drawing above. (3607909)

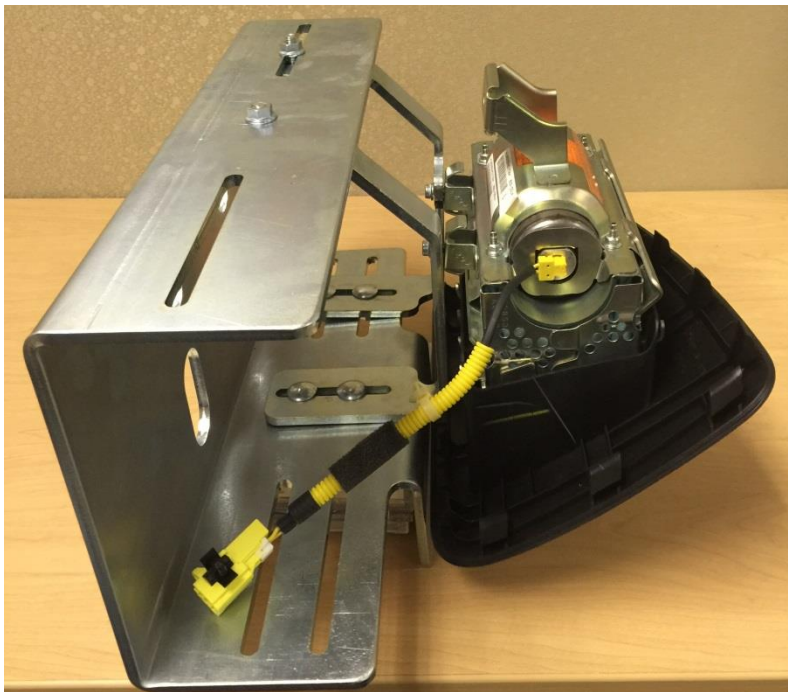

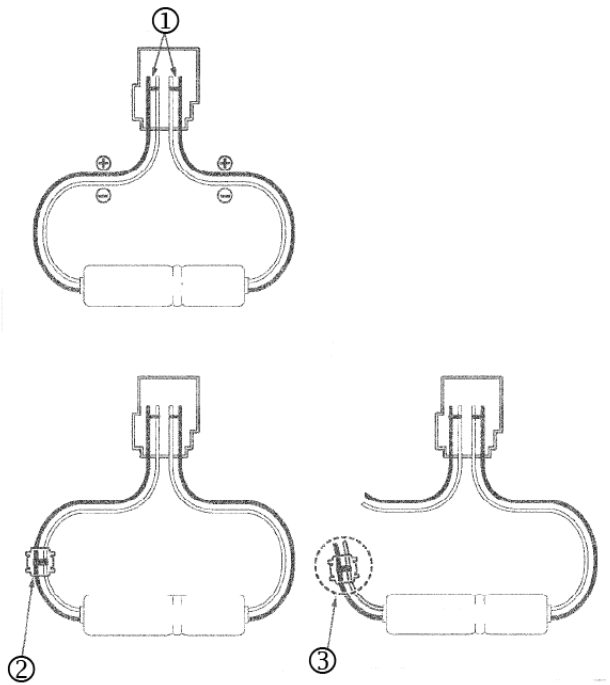

3470510

Note: The connector of an air bag inflator has a short-circuiting mechanism that eliminates voltage difference when disconnected (1). To allow for the replacement of the inflator module, a new short circuit using an electro tap (2) **MUST** be created **BEFORE** cutting the wires (3) and removing the inflator.

5. Create a short circuit before disconnecting the inflator wire harness.

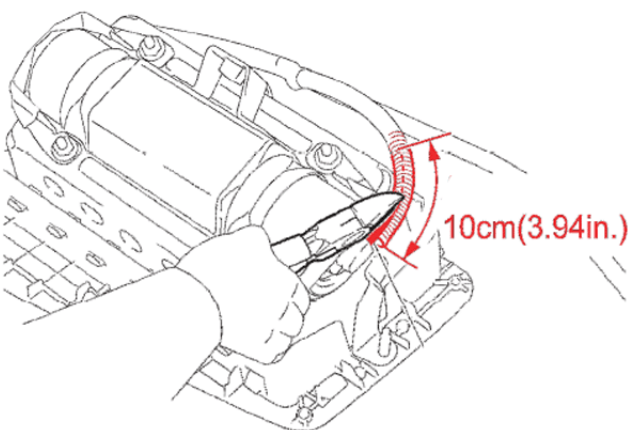

3470432

Caution: DO NOT damage the internal wires when cutting open the corrugate tube. DO NOT use a knife or razor blade to cut the tube to avoid damaging the wires. This step may be performed on either end if the inflator.

5.1 Cut open the corrugated tube on the yellow harness approximately 10 cm (4 in) using snipers.

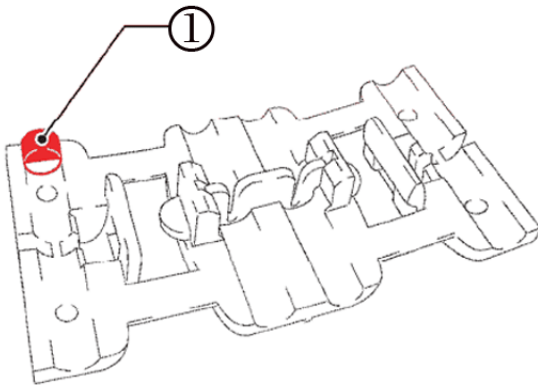

3470344

Danger: The tab on the electro tap must be removed to ensure a good short.

5.2 Cut off the tab of the electro tap (1) (included in the kit) shown in the illustration.

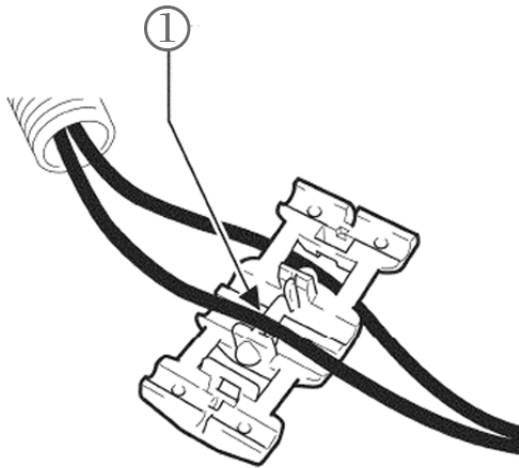

3470361

5.3 Short-circuit the two wires using the electro tap. Place one wire (1) in the electro tap as shown in the illustration.

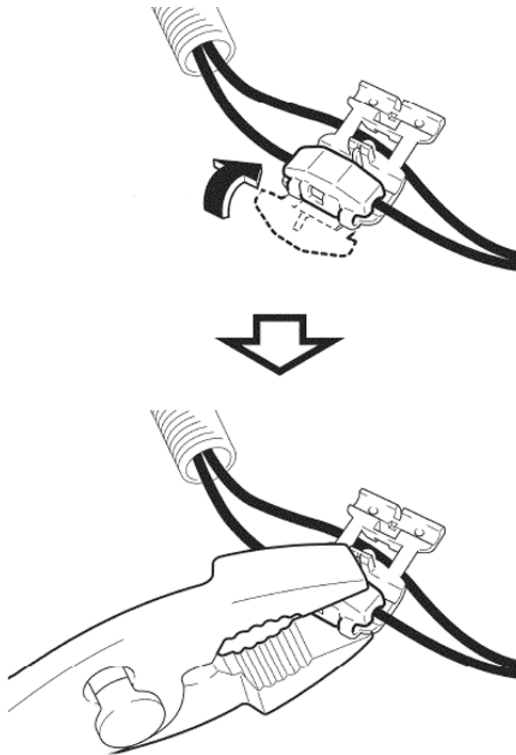

3470357

Note: Simultaneously working on the two wires tends to cause a mistake. Be sure to set the wire in the electro tap one wire at a time. Lock the electro tap firmly using pliers. If locked by hand, the electro tap may unfasten.

5.4 Fold and pinch the half of the electro tap where the first wire was just placed using pliers to lock firmly.

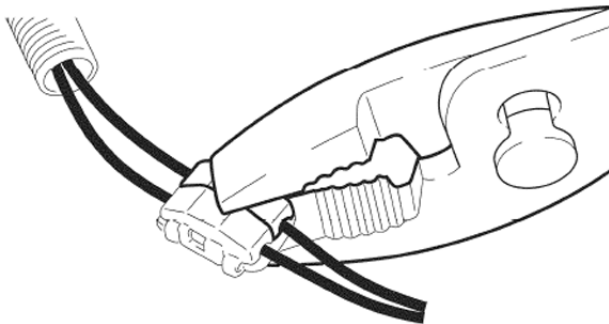

3470369

5.5 Set the other wire in the electro tap and lock in a similar way with pliers.

5.6 Cut wires to inflator.

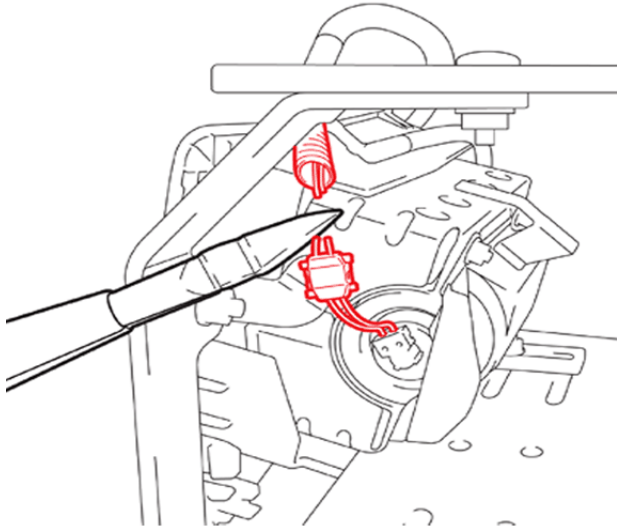

3607837

Danger: Do NOT measure resistance of the inflator wires. This may cause accidental activation of the inflator.

Caution: Make sure to cut the two wires at the correct location. Refer to the illustration.

6. Cut the two wires at the side of the electro tap opposite to the inflator (the side of the electro tap that is farthest away from the inflator).

Caution: DO NOT use power tools.

7. Remove the two 8mm self-locking nuts securing the stopper plate. Loosen but do not remove the other two nuts on the mounting bracket as leaving them in place will help keep the airbag assembly together.

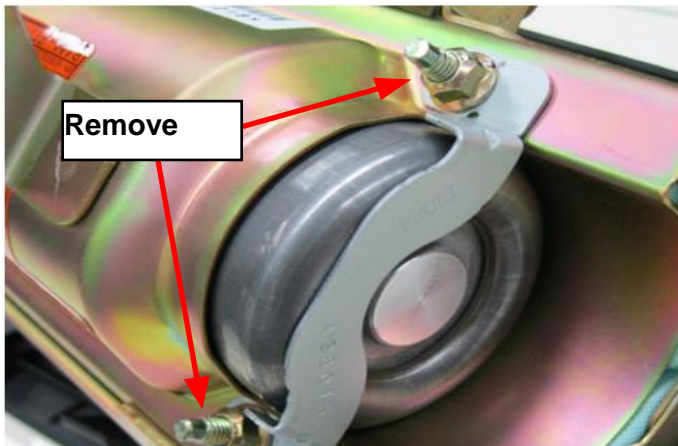

8. Remove the stopper plate.

9. Discard the 4 nuts as they are not to be reused.

10. Gently push in the 4 studs to loosen the inflator for removal

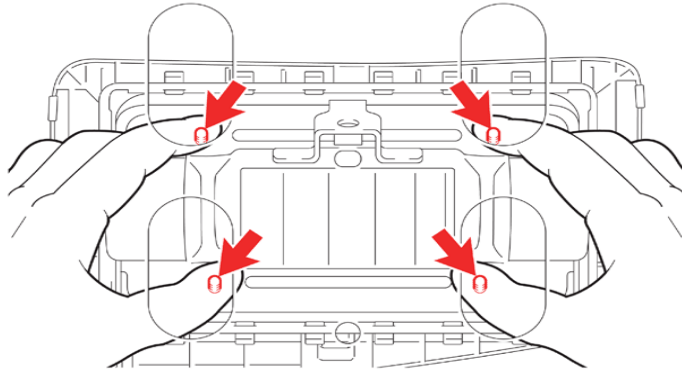

3607857

10.1 Remove the inflator. Use caution while guiding the harness through the stopper plate hole.



10.2 Remove the inflator from the air bag assembly and place it on a safe work surface.

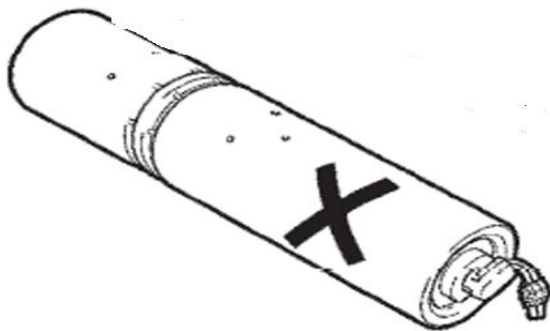

10.3 Put a mark on the removed inflator and store it in the provided replacement part box. Refer to the packaging instructions that were included with the new inflator module kit **and/or at the end of this bulletin.**

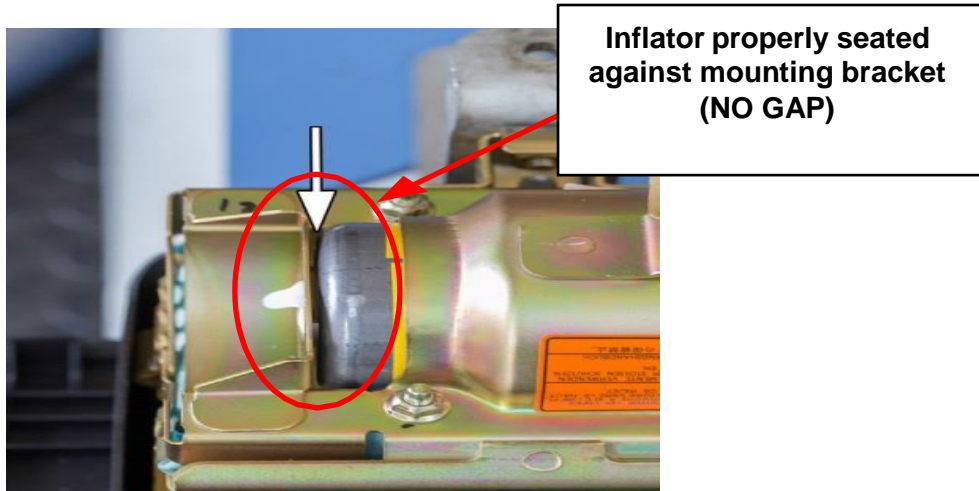

11. Carefully slide the new inflator into the air bag assembly, make sure to put the end with the harness connector in first and that the protective foil cover is still in place.

Warning: Confirm the flats on the stopper plate and inflator are aligned.

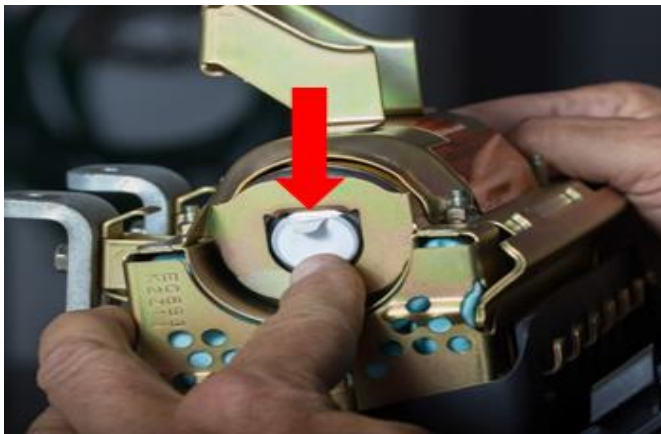

Note: DO NOT remove the seal until just before connecting the harness.

12. Confirm the inflator is flush mounted with no gap. Re-install the stopper bracket. Install the new nuts onto the 4 studs by hand. They will be torqued at a later step.

Note: DO NOT fully remove the seal until just before connecting the harness.

13. Fold the seal in order to prevent it from being caught under the position determining plate in the next step.

14. Tighten four (4) **NEW** plate nuts evenly in several increments in the order shown in the illustration below using a 10 mm socket driver while pushing the inflator. (You will encounter some resistance during tightening because these nuts are self-locking nuts.) **Torque Specification: 3.9 Nm (35 in-lb)**

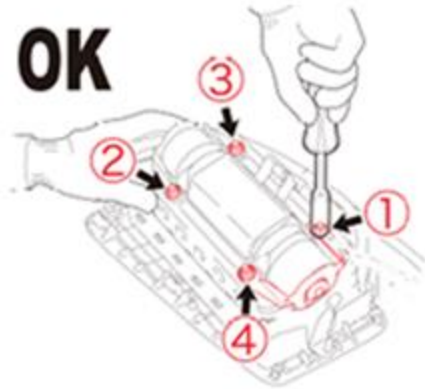

Caution: There will be some resistance when tightening the nuts because they are self-locking. Confirm the nuts are tightened correctly. **DO NOT** use a power tool, T-handle, or ratchet when tightening the nuts to avoid over-torquing.

Warning: The connector should be connected **IMMEDIATELY** after removing the seal. Once the connector is installed it **CANNOT** be removed. If the connector is installed in the incorrect orientation the terminals may be bent or the connector may not fully engage.

15. Connect the inflator connector (2).

15.1 Remove the connector seal from the inflator. Plug in the harness

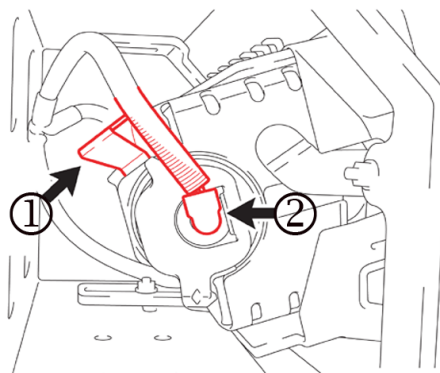

15.2 Confirm the alignment of the harness connector as shown in the illustration, and then connect the harness. The connector wires should lead toward the center mounting bracket (1) on the air bag assembly.

Reinstall the wiring harness retaining clip into its position on the mounting bracket.

16. Remove the air bag assembly from the bracket by removing the two Allen bolts and the air bag assembly. Place the air bag assembly on a cloth.

17. Peel the adhesive backing and install the new Sponge Tape onto the yellow harness tube first then adhere it to the airbag mounting bracket as shown in the illustration below.

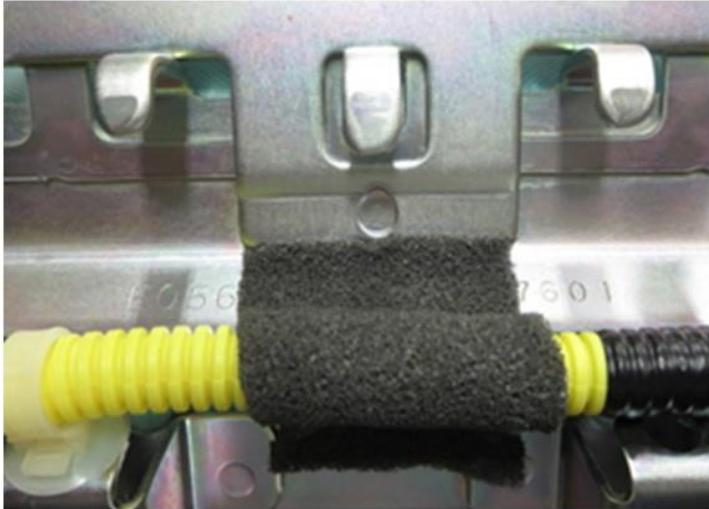

18. Inspect the air bag before installing it into the vehicle.
 - 18.1 Confirm that the 4 **NEW** plate nuts are installed and tight.
 - 18.2 Confirm the **NEW** stopper and position determining plates are installed.
 - 18.3 Confirm the flats on the position determining plate and inflator are aligned.
19. Confirm the orientation of the inflator; the yellow wires should face the right side of the vehicle.

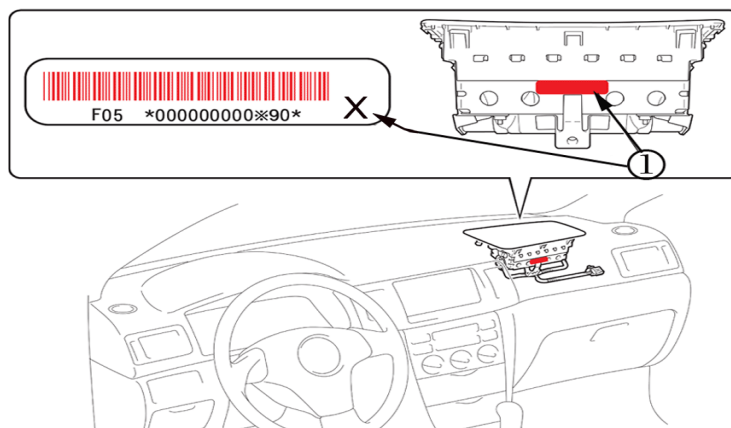

3610495

- 19.5 Using a pen or marker, put an 'X' in the lower right-hand corner of the air bag bar code label (1).
20. Install the instrument panel passenger air bag assembly. Refer to *Air bag Instrument Panel Module Replacement* in WIS.



Note: This field action bulletin provides service repair and Labor time information for replacing the passenger side air bag inflator module. Other repairs, if required, are to be billed under warranty, goodwill assistance or customer pay.

21. Connect scan tool and check for DTCs.

21.1 Clear DTCs, if present.

21.2 If DTCs are still present, record set DTCs on the job card.

22. Install the instrument panel (IP) compartment. Refer to Instrument Panel Compartment Replacement in WIS.

SERVICE PROCEDURE FOR SAAB 9-2X P/N 98279FE07

CAUTION: Refer to the “CAUTION” section in the General Description portion of Airbag System AB in the Body Section of the Service Manual before handling or servicing the airbag module!

STEP 1- PREPARATION:

- Turn the ignition “OFF” .
- Disconnect the Negative (ground) cable from the battery and wait **at least 20 seconds** before proceeding further
- Remove the glove box assembly following the procedure in the applicable Service Manual.

IMPORTANT: Whenever beginning to remove (or install) the airbag assembly, and periodically while performing the procedure or after stepping away, remove any possible static charge from your body by momentarily touching a clean, bare metal ground point on the vehicle (e.g. the door striker). Remove from your person all electronic devices including cellphones before proceeding.

- Disconnect the airbag module harness connector from the support beam bracket.

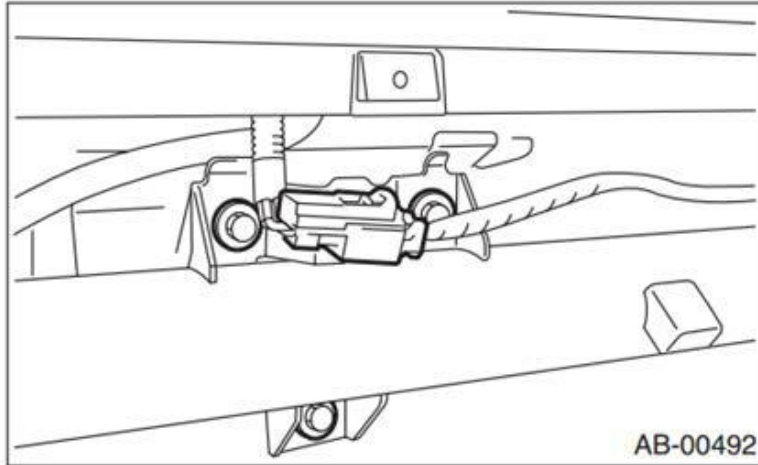

· Remove the 3 retaining bolts and **CAREFULLY** remove the airbag module from the vehicle and place it on a clean cloth to protect the dash trim surface portion from damage.

NOTE: There may be a Security Module secured with the lower airbag module mounting bolt on some models.

IMPORTANT: DO NOT destroy or damage the kit box as it **MUST** be used for the original inflator's return shipping.

- Open the Kit Box and confirm all the necessary components are included:
 - 4 Self-Locking nuts
 - New **Type 2** Inflator (pink collars on each end identify it as the replacement part)
 - New Inflator Harness
 - New Stopper Plate
 - Electro-Tap (red shorting crimp connector)
 - 1 ½" X 2 ¼" piece of self-adhesive Sponge Tape
 - Shipping Documentation and Instructions





IMPORTANT: The removed airbag module must be mounted to the Airbag Deployment Fixture (part number EL-51377) as shown in the photo below to better secure it during the inflator and wiring harness component replacement procedures. Always perform this work in an area away from others to reduce chances of inadvertent injury should any deployment occur. Take your surroundings into account to avoid possible hazards should inadvertent deployment occur or sources of static or other electricity that could potentially induce such a deployment.

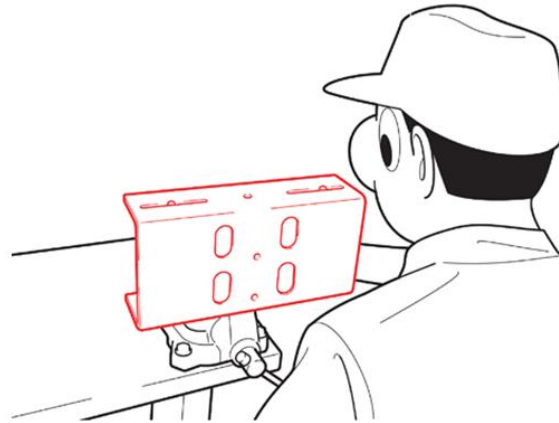
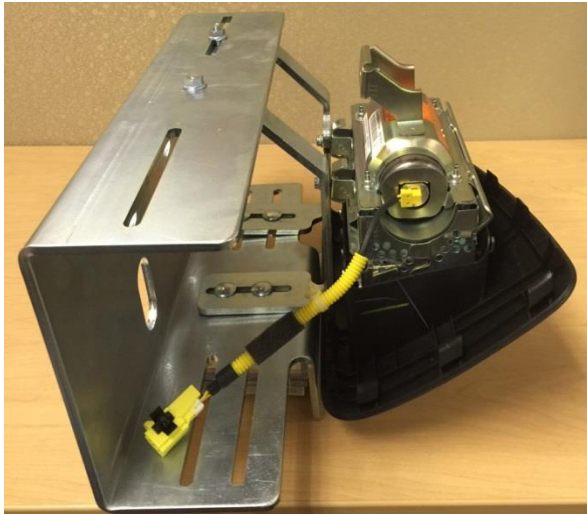

STEP 2- Peel the Sponge Tape and remove the harness clip from the retainer bracket by pushing the tangs inward with a flat-blade screwdriver as shown below. Always remove any Sponge Tape adhesive residue from the airbag mounting bracket using mild solvent on a clean shop cloth.

CAUTION: Never use any silicone-based products for this purpose.

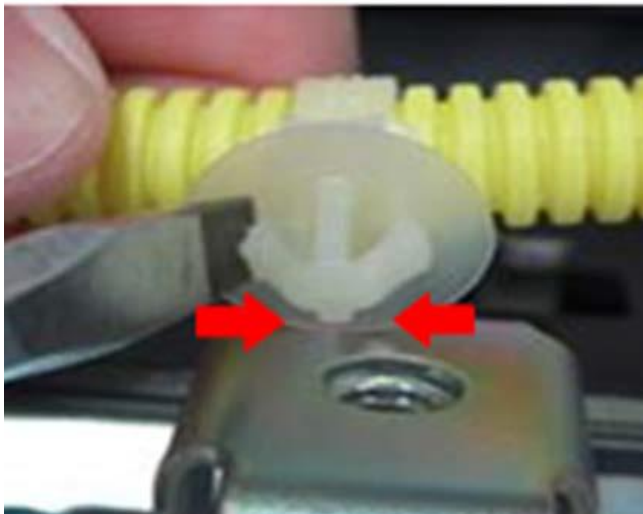



STEP 3- CAREFULLY cut the yellow harness cover enough (approximately 2 inches) to expose the 2 red (or yellow) wires inside and provide enough room to install the Electro- Tap (shorting) connector using a wire cutter or scissor (no knives or razors). **TAKE YOUR TIME AND BE CAREFUL TO NOT CUT THE 2 WIRES!**

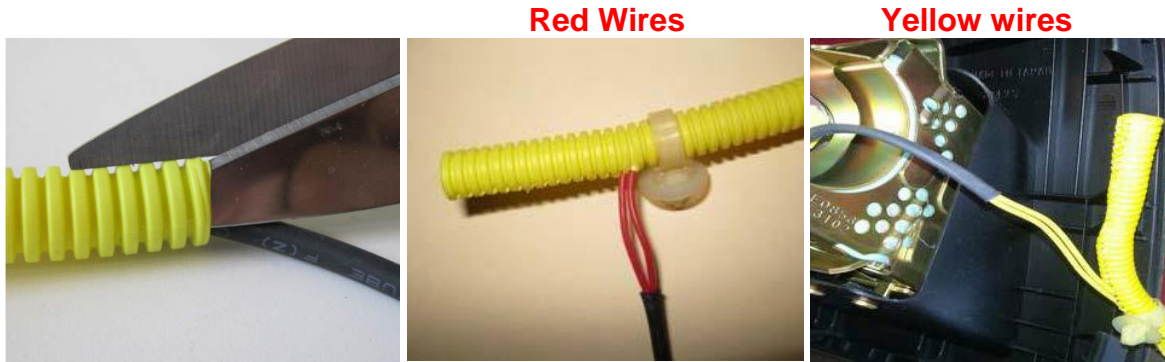

STEP 4- Short the 2 wires together by installing the Electro-Tap connector. The connector creates a short circuit which acts as a safeguard to prevent against static discharge that may deploy the removed inflator. The tab portion of the Electro-Tap connector **MUST** be cut off prior to use to insure a good short-circuit is made as shown in the illustration below. **Follow the sequence** below for installing the Electro-Tap connector. Use pliers to squeeze closed the two sections of the connector together, **one section at a time.**

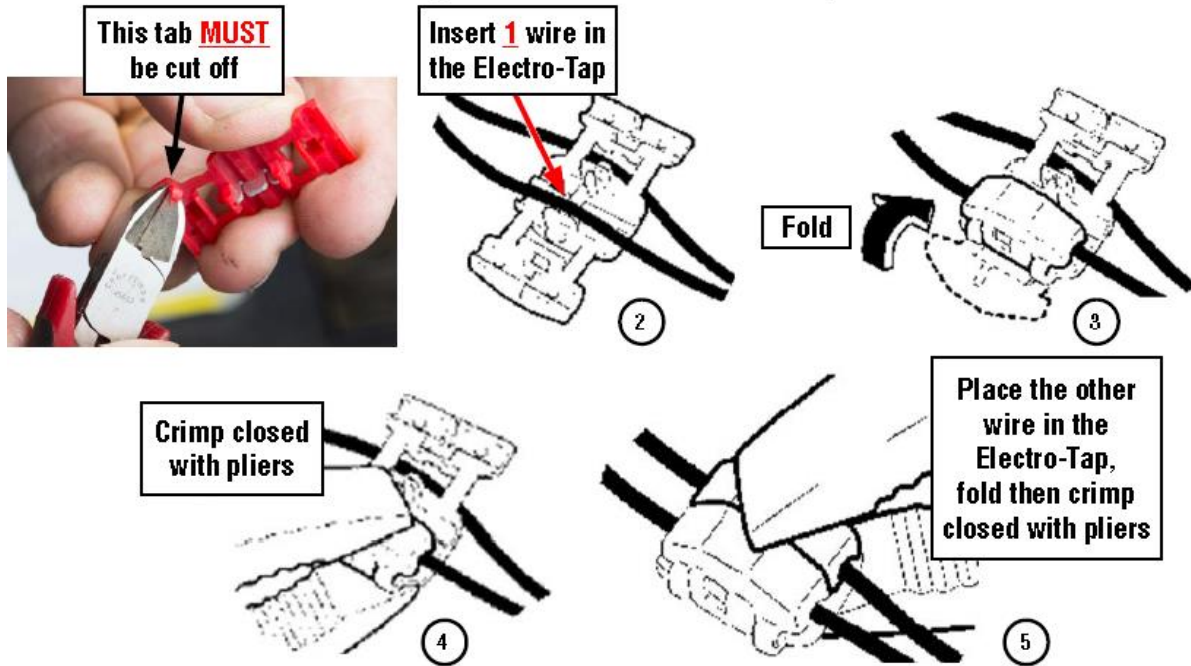

STEP 5- Once the Electro-Tap connector is fully crimped in place, cut the 2 wires on the body harness connector side of the Electro-Tap connector.

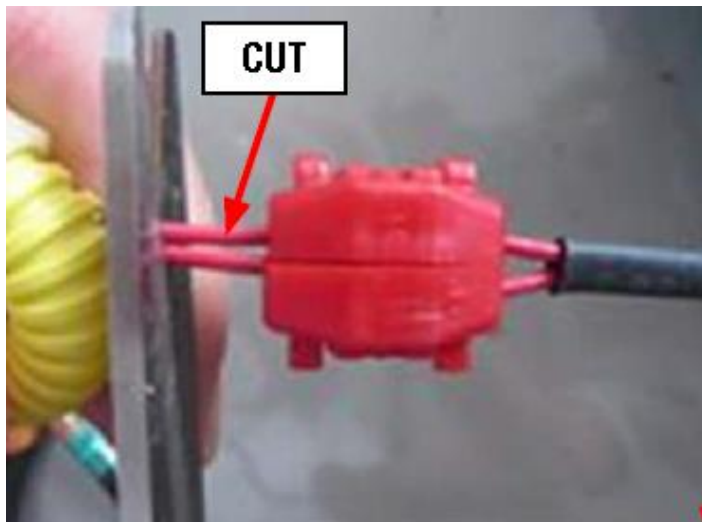

STEP 6- Remove the two 8mm self-locking nuts securing the stopper plate. Loosen but do not remove the other two nuts on the mounting bracket as leaving them in place will help keep the airbag assembly together.

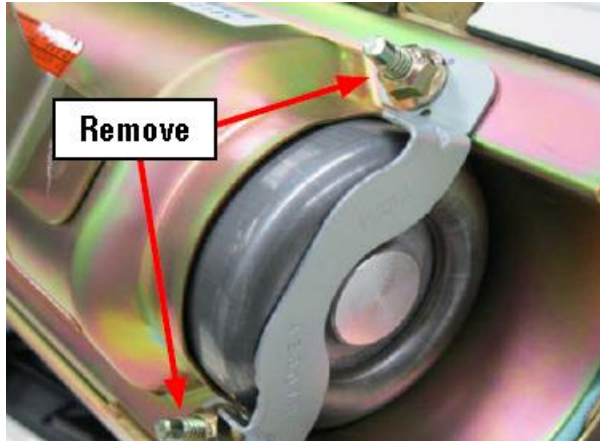

STEP 7- With the stopper plate removed and the other 2 self-locking nuts loosened, unseat the inflator off the mounting bracket end plate then rotate it slightly **CLOCKWISE** to make it easier to remove as shown in the photo to the right. Slide the inflator out of its mounting while feeding the cut off portion of the wiring harness through the “D-Shaped” hole in the end of the mounting bracket.

NEVER ATTEMPT TO REMOVE THE HARNESS FROM THE INFLATOR!

Place the removed original air bag inflator in the “cradle” of the Kit Box insert.



STEP 8- VERY IMPORTANT: Record the **11-digit alpha-numeric serial number for both the removed (Type 1) and 14-digit numeric serial number for the new (Type 2) inflator** on the Repair Order hard copy. This information will be required for completion of the Part Return Notice which will be forwarded by the retailer



to the PCC. The new 14 digit numeric serial number is also a requirement for claim entry.



STEP 9- Inspect the new **Type 2** inflator to confirm the locating protrusions on each of the pink collar portions are aligned as shown below. The “short” collar can be rotated as needed to align it with the protrusion on the “long” collar if necessary.

NOTE: The **Type 2** inflator is installed in the opposite direction of the original. This change puts the connector on the other end. The new harness has been extended approximately 2” to compensate.

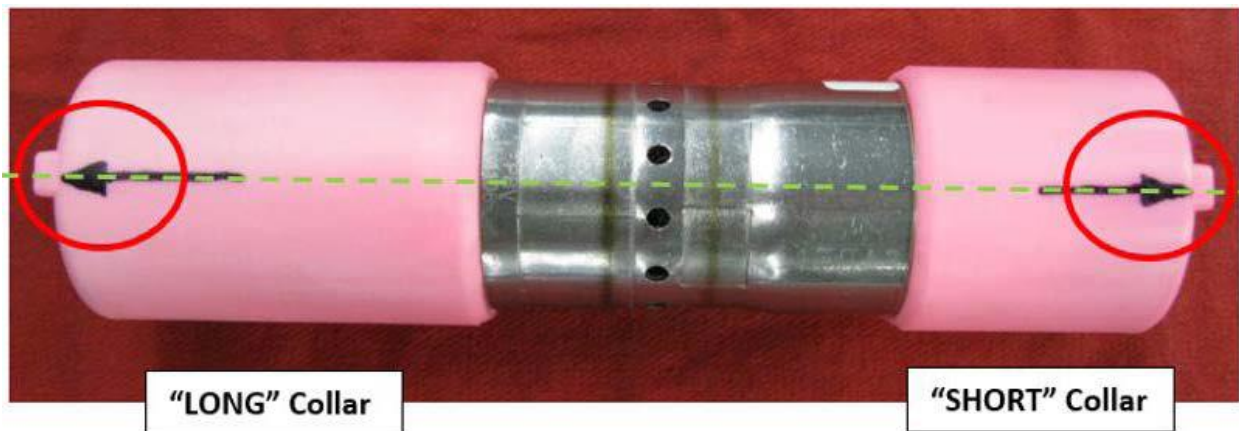

STEP 10- Install the new inflator into the mounting bracket, short collar with the “blank” (no harness connector) end going in first. The protrusion on the short collar will fit in the gap at the bottom of the fixed stopper plate portion. At the same time, the ridge portion of the inflator side of the

stopper plate will fit into the “notch” in the end of the collar. When properly installed, the end of the inflator will be seated tight against the mounting bracket with NO gap. DO NOT peel the white harness connection dust cover at this time.

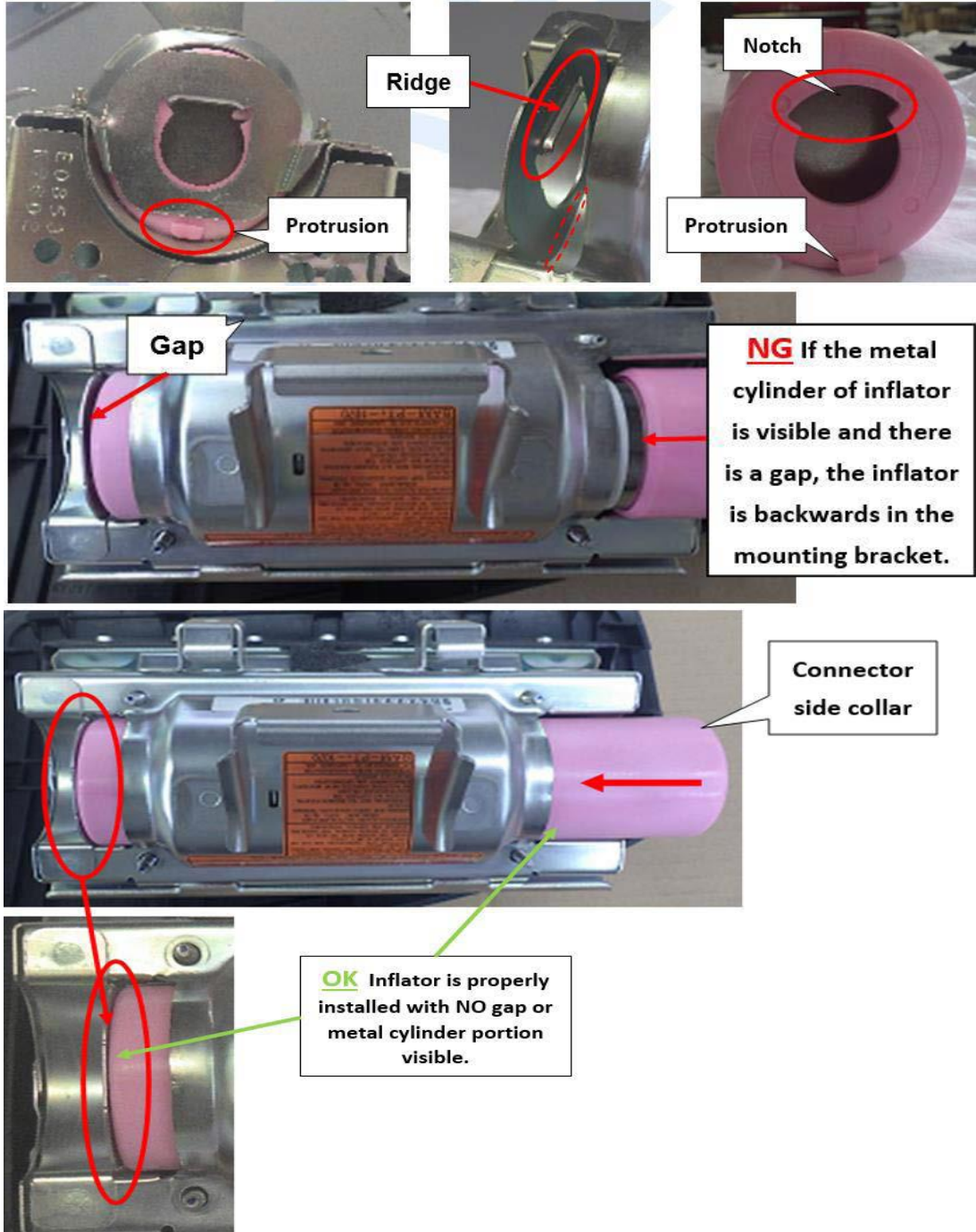

STEP 11- Install the new stopper plate over the harness connector end of the new inflator.

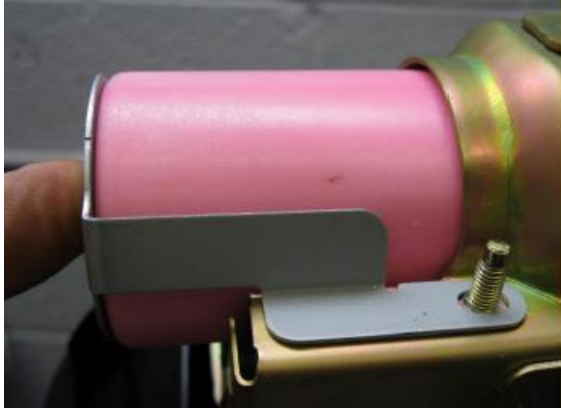

Always hold the stopper plate tight against the inflator as shown when installing and tightening the **NEW** self-locking nuts. **NEVER** reuse the original nuts.

Remove the 2 nuts still installed on the mounting bracket and replace them with 2 **NEW** self-locking nuts. Once all 4 **NEW** nuts are in place, torque to 31 - 38 inch pounds in the new sequence shown below. Use a marker to mark the nuts after torquing indicating they have been fully tightened.



STEP 12- Peel off the white dust cover and **CAREFULLY** align the tang of the new harness connector with the receiving slot in the inflator connector. This assures proper routing of the harness in relation to the airbag assembly mounting brackets.

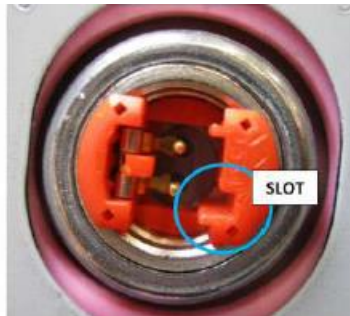



Once alignment is confirmed, push down firmly to engage the connector. When fully seated, press down on the yellow tab locking the connector to the inflator.

Step 13- Reinstall the wiring harness retaining clip into its position on the mounting bracket.

IMPORTANT: Confirm the harness is not twisted at the inflator connector as shown below.

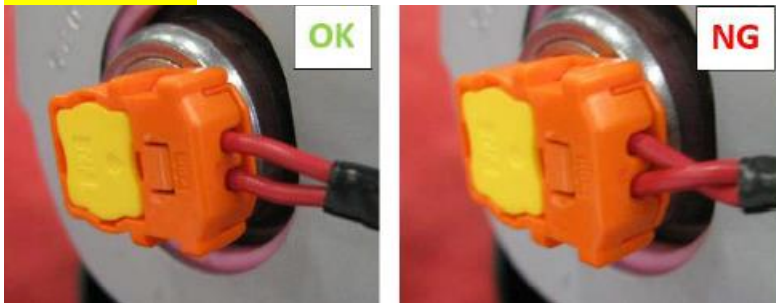

STEP 14- Peel the adhesive backing and install the new Sponge Tape onto the yellow harness tube first then adhere it to the airbag mounting bracket as shown in the illustrations below.

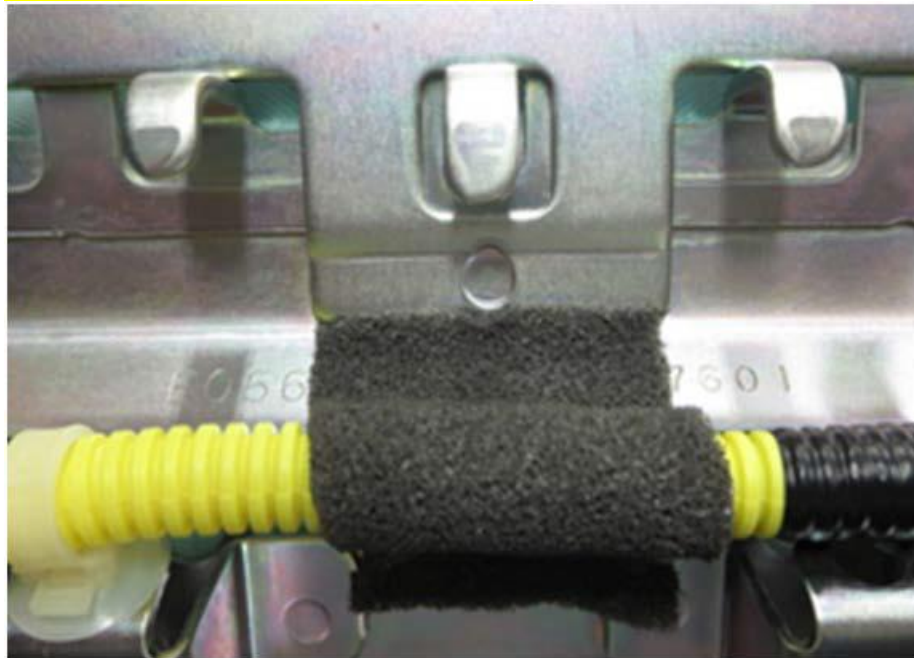

Placement of Sponge Tape

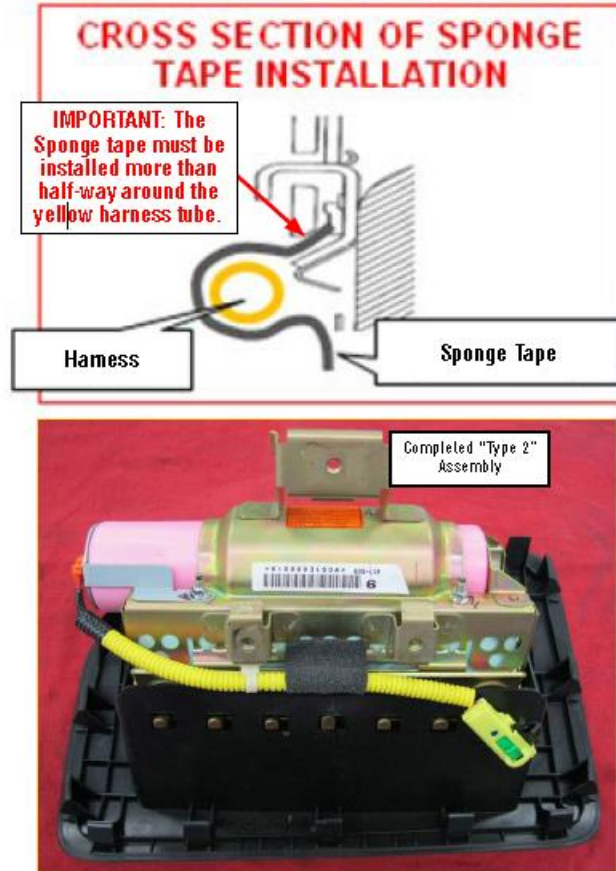

STEP 15- Reinstall the airbag assembly into the vehicle in reverse order of disassembly.

NOTE: If the accessory security module is installed to one of the airbag module mounting bolts, torque that specific bolt to 7.5 +/-1ft. lb. rather than the normal 5.4 ft. lb. specified in the Service Manual. Before installing the glove box assembly, reconnect the negative battery cable. Turn the ignition key "ON" and confirm the AIRBAG warning light comes on then cycles off properly. Once proper warning light operation is confirmed, reinstall the glove box assembly while making sure the cord loop for the opening dampener (if equipped) stays connected to complete the procedure.

STEP 16- Place the removed air bag inflator in the "cradle" of the Kit Box insert, with a completed SOA warranty parts tag (MSA5W402A) attached to it. The tag must contain the following information: **Claim Number, Repair Date, 17-digit VIN, and vehicle mileage.** Refer to the "PARTS RETURN PROCEDURES" section of this bulletin (page 4) for further return shipping instructions and information.

IMPORTANT: UNDER NO CIRCUMSTANCES SHOULD ANY AIR BAG INFLATORS BE RETURNED TO SAAB, ORIO or SUBARU OF AMERICA, INC.



WARRANTY TRANSACTION INFORMATION

Submit a claim using the table below.

CLAIM INFORMATION – US & Canada Saab Only

Labor Op.	Description	Failed Object	Fault-Reason Code	Loc. Code	Warr Type	Repair-Action Code	Labor Time	RAC
1503601	Replace Front Passenger Air Bag Inflator Module	15036	71	4	05	01	1.1	3



CUSTOMER NOTIFICATION – For U.S. and Canada

Saab-General Motors will notify customers of this recall on their vehicle.

The U.S. National Traffic and Motor Vehicle Safety Act provides that each vehicle that is subject to a recall of this type must be adequately repaired within a reasonable time after the customer has tendered it for repair. A failure to repair within sixty days after tender of a vehicle is prima facie evidence of failure to repair within a reasonable time. If the condition is not adequately repaired within a reasonable time, the customer may be entitled to an identical or reasonably equivalent vehicle at no charge or to a refund of the purchase price less a reasonable allowance for depreciation. To avoid having to provide these burdensome remedies, every effort must be made to promptly schedule an appointment with each customer and to repair their vehicle as soon as possible. In the recall notification letters, customers are told how to contact the U.S. National Highway Traffic Safety Administration if the recall is not completed within a reasonable time.

OSCs are to service all vehicles subject to this recall at no charge to customers, regardless of mileage, age of vehicle, or ownership, from this time forward. In summary, whenever a vehicle subject to this recall enters your vehicle inventory, or is in your facility for service in the future, you must take the steps necessary to be sure the recall correction has been made before selling or releasing the vehicle.

NOTE INFLATOR RETURNS

These Return Instructions are for the Continental US Saab OSC (48 States).

NOTE: Locations outside of the Continental United States (Hawaii, Alaska, Puerto Rico, Virgin Islands INCLUDING Mexico and Canada CANNOT follow below shipping instructions. Instead, Saab OSC in these locations MUST contact the following Takata/XPO USA representative directly for shipping instructions: Armando Gonzales- Tel#: 210-250-5039 or Email: Armando.Gonzales@xpo.com
SCTakataRestrains_International@XPO.com

1. Shipping Documents

a) Box Label

- Supplied with each Kit
- To be affixed to each box



b) Over-pack Label

- To be supplied by XPO.
- To be affixed to the outside of each pallet



c) Bill of Lading

- To be supplied by XPO.
- Print 2 copies: 1 for Saab OSC Records, 1 for LTL Driver



d) ERG Document

- To be supplied by XPO.
- To be provide by the Saab OSC to the LTL Driver for each shipment



2. Packing Instructions

a) Confirm box is in acceptable condition. If a new box is needed, follow the New Box instructions located in Box 8 of this page.

b) Place the un-deployed air bag inflator in the "cradle" of the box insert.



3. Closure Instructions

a) Close the top box flap, per box closure instructions located on front panel of box.



4a. Shipping Instructions - Label each Box

a) New Labels began shipping in each kit starting mid August, 2015

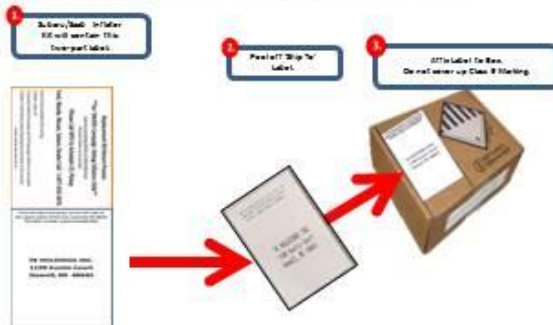

4b. Shipping Instructions - Label each Box

a) If you continue receiving Inflator Kits with the original Fedex Documentation:

1. Peel off the backing of the Fedex Ground PRP Shipping label and affix to top of box to left of the Class 9 label.
- Use the scribe line on the box as a guide
- The FedEx Ground PRP Shipping label must not touch any portion of the printing to the right of the scribe line.
2. Discard the remaining Documentation
3. **Do Not** contact FedEx



5. Shipping Instructions - Prepare the shipment or pallet

- Accumulate and package kits
- Arrange Kits on Pallet (if needed) as pictured here
 - 20 boxes per row/layer (5x4)
 - 10 rows/layers per pallet (200 boxes)
- Shrink-wrap Kits to Pallet if used
- Affix Over-pack Label on (1) side of Pallet (Not on Top)



6. Shipping Instructions - Schedule LTL Pickup

a) **Every 90 days** (or upon accumulating 200 kits 1 Over-pack/Pallet)
Call XPO at 1-877-650-3476

b) Have the following Information Available

- OSC #
- Quantity of kits/packs/pallets
- Quantity of Inflator Kits in each package/pallet
- Email Address where shipping Documentation can be received

7. Shipping Instructions - Ship

- Give 1 Copy of BOL and 1 Copy of ERG to Driver
- Retain 1 Copy of BOL for Saab OSC records and archive for 2 Years

8. Requesting a New Box / Shipping Labels

If a new box or replacement shipping labels are needed, please contact the representative listed below by phone or email to request replacement materials.

Primary Contact- XPO Customer service RepTel #: 210-250-5079

E-Mail: SCFieldAction.14305@xpo.com

To help expedite your request, please be prepared to provide the following information:

- Serial number on the original box
- What Type of shipping material needed
 - Replacement Box
 - Two Part Return Label
 - Bill of Lading
 - ERG Form
 - OSC Shipping Information
 - Contact name
 - OSC Address
 - Phone Number

