



Michael A. Berardi
 Director
 Service Engineering Operations
 Ford Customer Service Division

Ford Motor Company
 P. O. Box 1904
 Dearborn, Michigan 48121

January 17, 2017

TO: All U.S. Ford and Lincoln Dealers

SUBJECT: **Safety Recall 15S27 – Supplement #1**
 Certain 1998-2003 Model Year Windstar Vehicles Repaired Under Safety Recall 10S13 with Rear Axle Reinforcement Brackets
 Rear Axle Inspection

REF : **Safety Recall 10S13 – Supplement #12**
 Certain 1998-2003 Model Year Windstar Vehicles Operated in Corrosion States
 Rear Axle Inspection and Repair

New! REASON FOR THIS SUPPLEMENT

- *Removing references to Customer Satisfaction Program 15N02, which expired October 31, 2016.*

AFFECTED VEHICLES

Vehicle	Model Year	Assembly Plant	Build Dates
Windstar	1998-2003	Oakville	September 2, 1997 through Job Last 2003

Affected vehicles were repaired with rear axle reinforcement brackets under Safety Recall 10S13. Affected vehicles are identified in OASIS and FSA VIN Lists.

REASON FOR THIS SAFETY RECALL

In some of the affected vehicles the rear axle reinforcement brackets may not have been installed properly, which could allow the rear axle to completely fracture and may increase the risk of a crash.

New! SERVICE ACTION

Dealers are to inspect the rear axle reinforcement brackets for proper installation and potential axle cracks, including bracket position on the axle beam and evidence of adhesive use.

- *If brackets are installed properly, no further service action is required.*
- If brackets are not installed properly, dealers are to take photos of the improperly installed bracket(s), retain the photos with other repair documentation for future reference, and replace the rear axle under Safety Recall 15S27.

OWNER NOTIFICATION MAILING SCHEDULE

Owner Letters are expected to be mailed the week of October 19, 2015. Dealers should repair any affected vehicles that arrive at their dealerships, whether or not the customer has received a letter.

PLEASE NOTE:

Federal law requires dealers to complete this recall service before a new vehicle is delivered to the buyer or lessee. Violation of this requirement by a dealer could result in a civil penalty of up to \$7,000 per vehicle. Correct all vehicles in your new vehicle inventory before delivery.

ATTACHMENTS

Attachment I: Administrative Information
Attachment II: Labor Allowances and Parts Ordering Information
Attachment III: Technical Information
Owner Notification Letter

QUESTIONS & ASSISTANCE

For questions and assistance, contact the Special Service Support Center (SSSC) via the SSSC Web Contact Site. The SSSC Web Contact Site can be accessed through the Professional Technician Society (PTS) website using the SSSC link listed at the bottom of the OASIS VIN report screen or listed under the SSSC tab.

Sincerely,



Michael A. Berardi

Safety Recall 15S27 – Supplement #1

Certain 1998-2003 Model Year Windstar Vehicles Repaired Under Safety Recall 10S13 with
Rear Axle Reinforcement Brackets
Rear Axle Inspection

OASIS ACTIVATION

OASIS will be activated on September 30, 2015.

FSA VIN LISTS ACTIVATION

FSA VIN Lists will be available through <https://web.fsavinlists.dealerconnection.com> on September 30, 2015. Owner names and addresses will be available by October 30, 2015.

NOTE: Your FSA VIN Lists may contain owner names and addresses obtained from motor vehicle registration records. The use of such motor vehicle registration data for any purpose other than in connection with this recall is a violation of law in several states, provinces, and countries. Accordingly, you must limit the use of this listing to the follow-up necessary to complete this recall.

STOCK VEHICLES

Use OASIS to identify any affected vehicles in your used vehicle inventory.

SOLD VEHICLES

- Owners of affected vehicles will be directed to dealers for repairs.
- Immediately contact any of your affected customers whose vehicles are not on your VIN list but are identified in OASIS. Give the customer a copy of the Owner Notification Letter (when available) and schedule a service date.
- Correct other affected vehicles identified in OASIS which are brought to your dealership.

TITLE BRANDED / SALVAGED VEHICLES

Affected title branded and salvaged vehicles are eligible for this recall.

ADDITIONAL LABOR TIME AND/OR PARTS

Submit a request to the SSSC Web Contact Site prior to the repair if you have any of the following:

- Damage that you believe was caused by the covered condition.
- A condition that requires additional labor and/or parts to complete the repair.
- Aftermarket equipment or non-Ford modifications to the vehicle which might prevent the repair of the covered condition.

Requests for approval after completion of the repair may not be granted. Ford Motor Company reserves the right to deny coverage for related damage in cases where the vehicle owner has not had this recall performed on a timely basis. Additional related damage parts are subject to random selection for return to the Ford Warranty Parts Analysis Center (WPAC).

Safety Recall 15S27 – Supplement #1

Certain 1998-2003 Model Year Windstar Vehicles Repaired Under Safety Recall 10S13 with
Rear Axle Reinforcement Brackets
Rear Axle Inspection

New! OWNER REFUNDS

Refunds are not approved under Safety Recall 15S27.

RENTAL VEHICLES

The use of rental vehicles is not approved for this program.

CLAIMS PREPARATION AND SUBMISSION

- Enter claims using Direct Warranty Entry (DWE) or One Warranty Solution (OWS).
 - DWE: refer to ACESII manual for claims preparation and submission information.
 - OWS: when entering claims in DMS software, select claim type 31: Field Service Action. The FSA number (15S27) is the sub code.
- Additional labor and/or parts must be claimed as related damage on a repair line that is separate from the repair line on which the FSA is claimed. Additional labor and/or parts require prior approval from the SSSC via the SSSC Web Contact Site.

Safety Recall 15S27 – Supplement #1

Certain 1998-2003 Model Year Windstar Vehicles Repaired Under Safety Recall 10S13 with
Rear Axle Reinforcement Brackets
Rear Axle Inspection

New! LABOR ALLOWANCES

Description	Labor Operation	Labor Time
<i>Inspect Rear Axle – PASS – no further service action is required</i>	15S27A	0.2 Hours
Replace Rear Axle (includes inspection and photograph)	15S27B	1.1 Hours

PARTS REQUIREMENTS / ORDERING INFORMATION

Part Number	Description	Order Quantity
2F2Z-4B435-AB	Rear Axle	1

The DOR/COR number for this recall is 51003.

Order your parts through normal order processing channels.

Less than 1% of the affected vehicle population that received rear axle reinforcement brackets under Safety Recall 10S13 are expected to require rear axle replacement.

DEALER PRICE

For latest prices, refer to DOES II.

PARTS RETENTION AND RETURN

Follow the provisions of the Warranty and Policy Manual, Section 1 “WARRANTY PARTS RETENTION AND RETURN POLICIES.”

EXCESS STOCK RETURN

Excess stock returned for credit must have been purchased from Ford Customer Service Division in accordance with Policy Procedure Bulletin 4000.

CERTAIN 1998-2003 MODEL YEAR WINDSTAR VEHICLES REPAIRED UNDER SAFETY RECALL 10S13 WITH REAR AXLE REINFORCEMENT BRACKETS – REAR AXLE INSPECTION AND REPAIR

NEW ! OVERVIEW

Determine if repairs completed under Safety Recall 10S13 were performed properly. If repairs were not completed properly, the rear axle must be replaced under Safety Recall 15S27. If repairs were completed properly under Safety recall 10S13, *no further service action is required.*

NEW ! AXLE REINFORCEMENT BRACKET INSPECTION

1. Inspect and verify both rear axle reinforcement brackets are positioned within 0 to 38 mm (0 to 1.5 in) from the top of the rear axle weld on each side of the axle. Inspect for evidence that adhesive was used during rear axle reinforcement bracket installation. See Figures 1 and 2.

- *If both rear axle reinforcement brackets are positioned within 0 to 38 mm (0 to 1.5 in) from the top of the rear axle weld and the use of adhesive is evident, this inspection has passed. No further service is required.*
- If either rear axle reinforcement bracket is not positioned within 0 to 38 mm (0 to 1.5 in) from the top of the rear axle weld and/or the use of adhesive is not evident, the inspection has failed. Photograph the rear axle reinforcement bracket(s) and/or missing adhesive for dealer records. Use a tape measure to illustrate the incorrect rear axle reinforcement bracket-to-axle weld distance in the photograph. Proceed to Rear Axle Replacement on [Page 2](#).

NOTE: RH rear axle reinforcement bracket shown, LH similar.

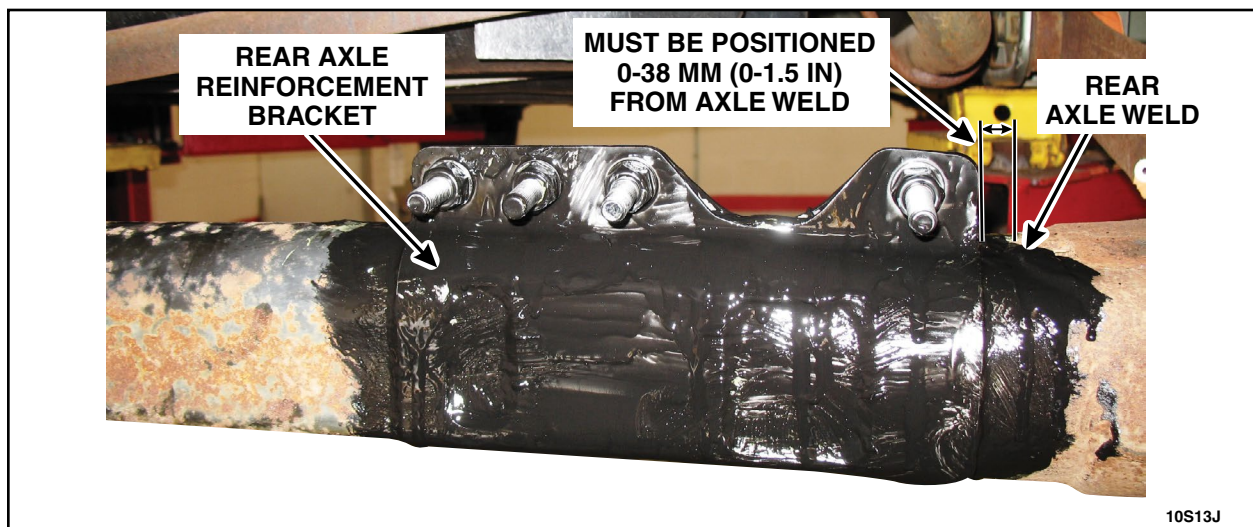

FIGURE 1



NOTE: RH rear axle reinforcement bracket shown, LH similar.

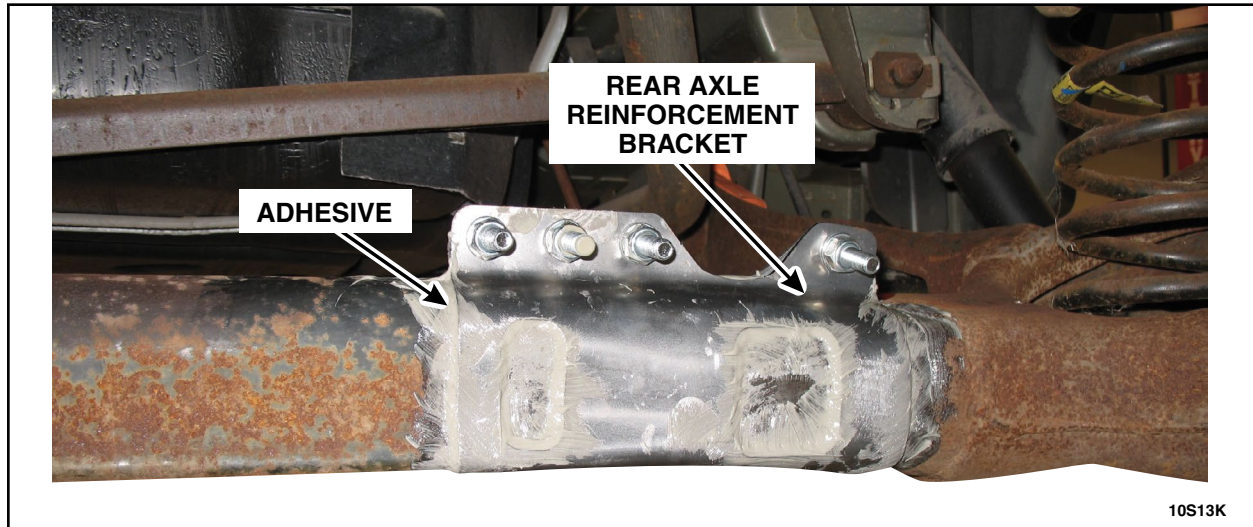

FIGURE 2

NEW ! REAR AXLE REPLACEMENT

Removal

NOTICE: Suspension fasteners affect performance of vital components and systems. The failure of suspension fasteners can result in major service expense. If replacement is necessary, they must be replaced with the same part number, or an equivalent part. Do not use a replacement part of lesser quality or substitute design. Torque values must be used as specified during reassembly to ensure proper retention of these parts.

NOTE: The following rear axle replacement procedure is different than the procedure described in the Workshop Manual (WSM). The procedure was revised because the emergency brake cable and service brakes do not need to be disconnected in order to remove and replace the rear axle.

1. **NOTE:** To prevent the brake drum from sliding off the hub, reinstall one wheel nut on each hub. Remove both rear wheel and tire assemblies. Please follow WSM procedures in Section 204-04.



2. Remove the parking brake cable bracket nuts and position the parking brake cable brackets aside.
See Figure 3.

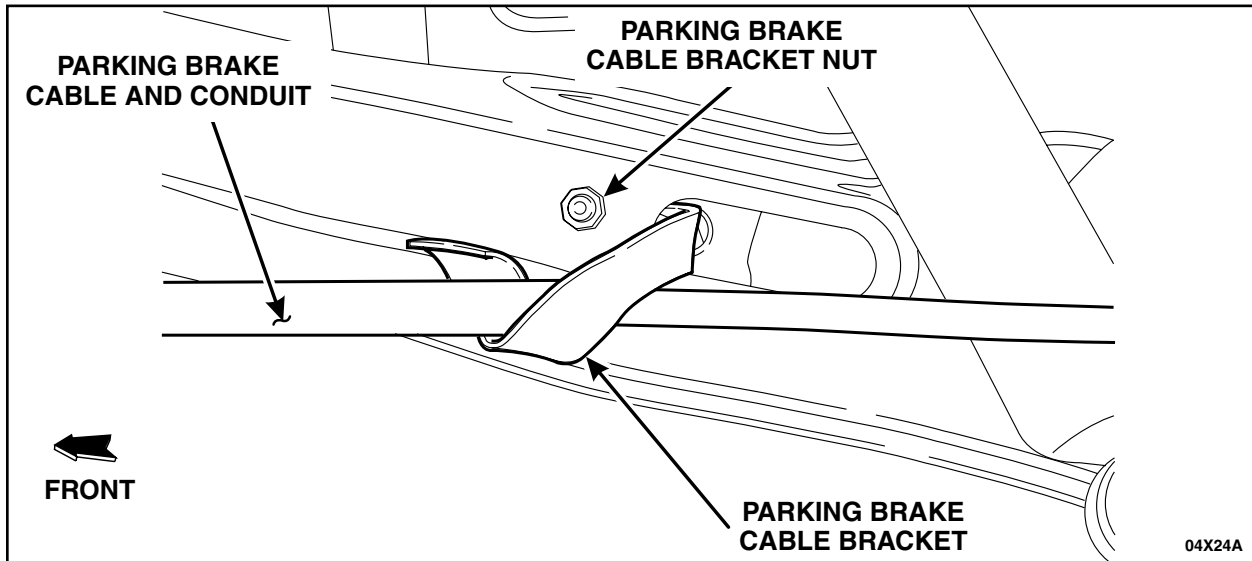

FIGURE 3

3. Secure the rear axle to High Lift Transmission Jack 014-00942 or equivalent.
4. Disconnect the track bar from the rear axle. *See Figure 4.*
 - a. Remove the track bar bolt.
 - b. Remove the track bar from the rear axle track bar mounting bracket.
 - c. Remove the J-nut from the rear axle track bar mounting bracket. The bolt and J-nut will be reused on the **new** rear axle. If the bolt or J-nut has been damaged, replace as necessary.

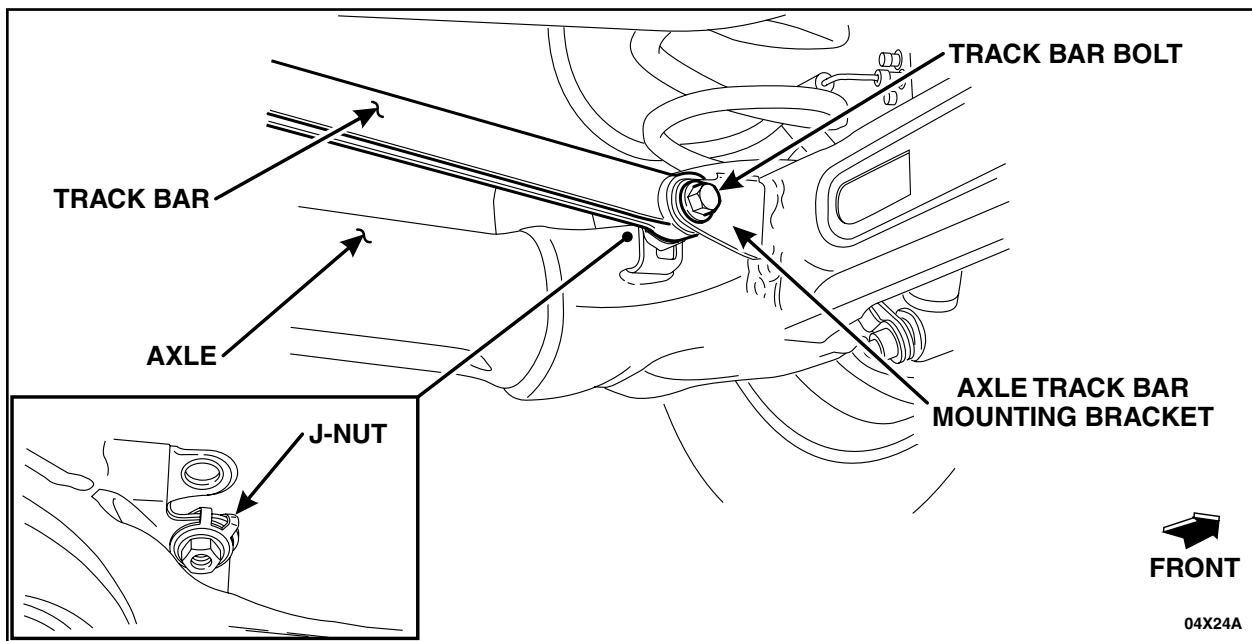

FIGURE 4



5. Remove the shock absorber lower bolts.

6. **NOTE:** The spring insulators may come out with the spring when the spring is removed.

Carefully lower the rear axle assembly enough to remove the rear springs. *See Figure 5.*

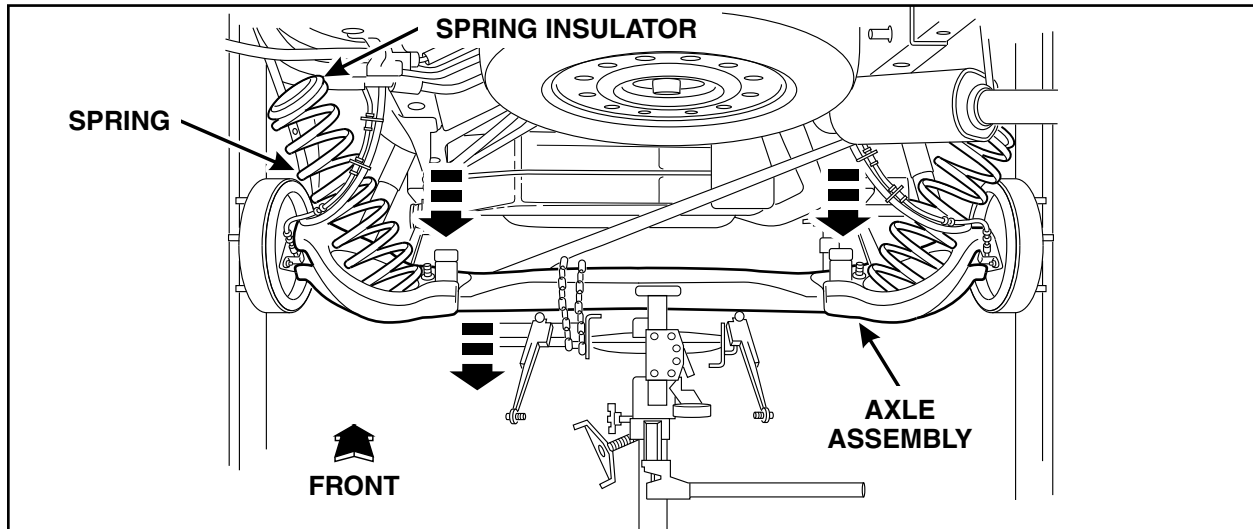

FIGURE 5

7. Remove the four spindle retaining nuts. *See Figure 6.*

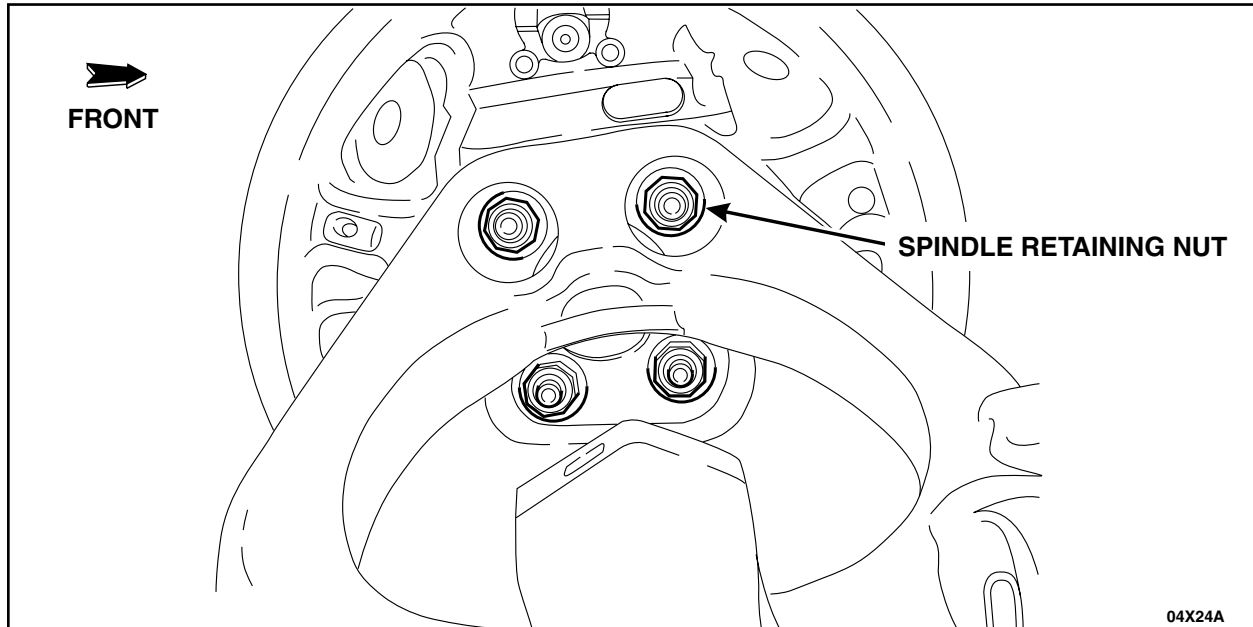

FIGURE 6

04X24A



8. **NOTICE:** When removing the spindle, hub and brake assembly, never allow it to hang from the brake caliper flexible hose. To prevent damage to the flexible hose, provide suitable support.

Position the spindle, hub and brake assemblies aside. *See Figure 7.*

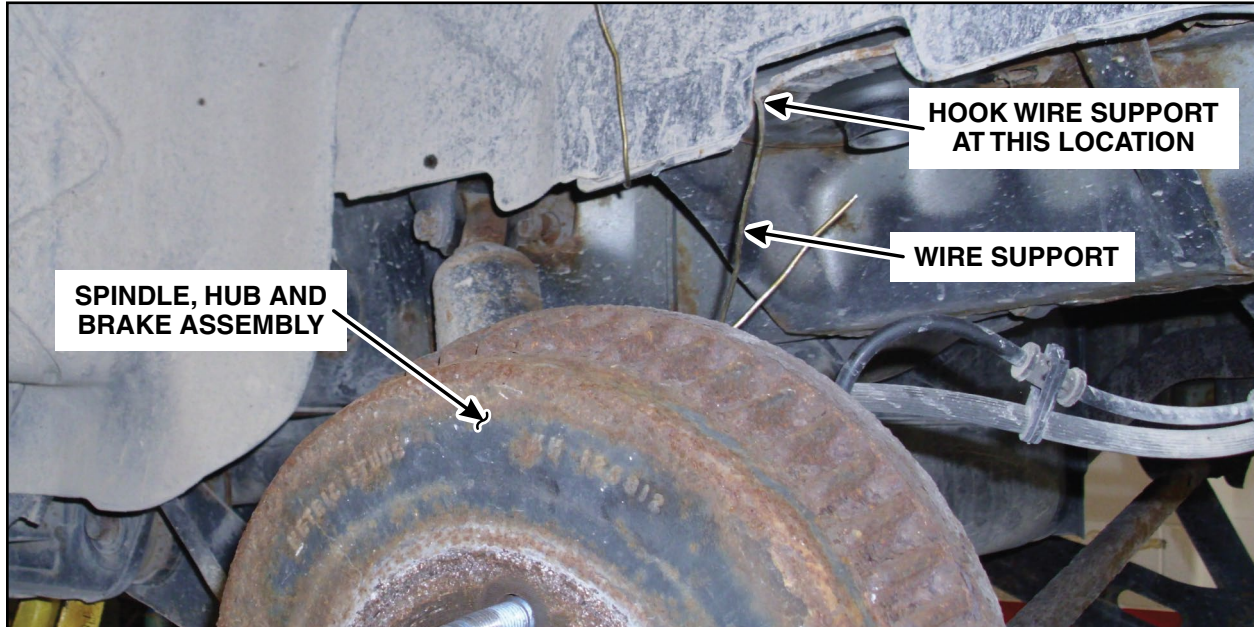

FIGURE 7

9. Remove the trailing arm-to-subframe bolts. *See Figure 8.*

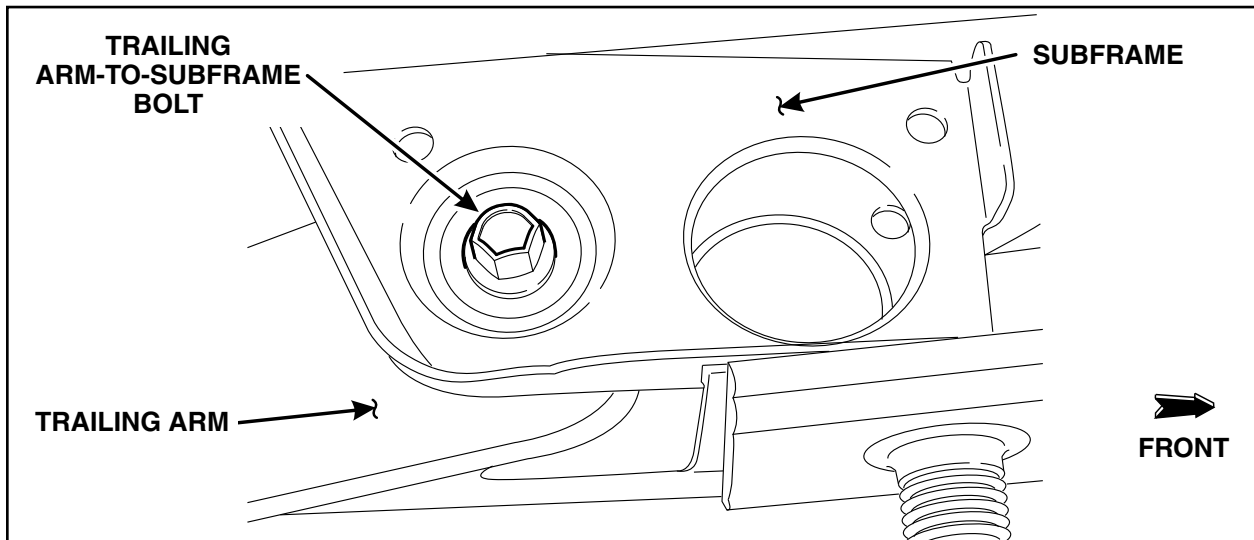

FIGURE 8



10. Carefully lower the rear axle and remove it from the vehicle.
11. **NOTE:** If the spring lower insulators did not come out with the springs, remove the insulators from the rear axle assembly.

Remove the jounce bumper bolts and bumpers, and if necessary, the spring lower insulators. The jounce bumpers and the spring lower insulators will be reused with the **new** rear axle.

Installation

NOTICE: Do not tighten the rear suspension fasteners until the rear axle has been raised and the rear suspension has been loaded. By lifting the rear axle and loading the rear suspension, it will simulate the vehicle's ride height. Failure to follow these instructions may result in incorrect clamp load and bushing damage may occur.

12. Install the jounce bumpers, and if necessary, the spring lower insulators on the **new** rear axle.
 - Tighten to 25 Nm (18 lb-ft).
13. Using a High Lift Transmission Jack 014-00942 or equivalent, raise the rear axle assembly in position and install the trailing arm-to-subframe bolts. *See Figure 8.*
14. Position the spindle, hub and brake assemblies in place. *See Figure 7.*
15. Install the four spindle retaining nuts. *See Figure 6.*
 - Tighten to 70 Nm (52 lb-ft).
16. **NOTE:** Make sure the spring upper insulators are positioned correctly on the springs.

Install the springs on the rear axle assembly. Make sure the springs are correctly seated.
17. Raise the rear axle assembly and position the shock absorbers on the rear axle. Install the shock absorber lower bolts.
18. Install the J-nut on the rear axle track bar mounting bracket. Position the track bar on the rear axle track bar mounting bracket and install the track bar bolt. *See Figure 4.*
19. Load the rear suspension by raising the axle assembly. Once the rear suspension has been loaded, tighten the following components:
 - a. Tighten the trailing arm-to-subframe bolts to 133 Nm (98 lb-ft).
 - b. Tighten the shock absorber lower bolts to 80 Nm (59 lb-ft).
 - c. Tighten the track bar bolt to 80 Nm (59 lb-ft).



20. Remove High Lift Transmission Jack 014-00942 or equivalent.
21. Position the parking brake cable brackets in place and install the parking brake cable bracket nuts.
See Figure 3.
 - Tighten to 25 Nm (18 lb-ft).
22. Install both rear wheel and tire assemblies. Please follow WSM procedures in Section 204-04.
23. Lower the vehicle.

