

Quick Guide
WRX
WRX STI
2019



Love. It's what makes a Subaru, a Subaru.



© 2018 Subaru of America, Inc. All rights reserved.

Contents may not be reproduced in whole or in part without prior written permission of publisher. Specifications in this Guide are based on the latest product information available at the time of publication. Some images shown are for illustration purposes only. Some equipment shown in photography within this Guide is optional at extra cost. Specific options may be available only in combination with other options. Specific combinations of equipment or features may vary from time to time, and by geographic area. Subaru of America, Inc. reserves the right to change or discontinue at any time, without notice: Prices, colors, materials, equipment, accessories, specifications, models and packages, without incurring any obligation to make the same or similar changes on vehicles previously sold. Colors shown may vary due to reproduction and printing processes. Subaru of America, Inc. is not responsible for typographical errors.

Aha™ is a trademark of Harman International Industries, Inc. Alcantara® is a registered trademark of Alcantara S.p.A., and Alcantara is produced by the Toray Group. App Store® is a registered trademark of Apple, Inc. Apple® is a registered trademark of Apple, Inc. BBS® is a registered trademark of BBS Kraftfahrzeugtechnik, AG. Bluetooth® is a registered trademark of Bluetooth SIG, Inc. Brembo® is a registered trademark of Freni Brembo, S.p.A. GreenEdge® is a registered trademark of Harman International Industries, Inc. Harman Kardon® is a registered trademark of Harman International Industries, Inc. HD Radio® is a registered trademark of iBiquity Digital Corporation. HomeLink® is a registered trademark of Prince Corporation, a wholly owned subsidiary of Johnson Controls. iHeart® Radio is a registered trademark of iHeartMedia, Inc. iPod® is a registered trademark of Apple, Inc. iTunes® is a registered trademark of Apple, Inc. Metal-Matrix Diaphragm (MMD®) is a registered trademark of Harman International Industries, Inc. MirrorLink™ is a trademark of Car Connectivity Consortium, LLC. Pandora® is a registered trademark of Pandora Media, Inc. Siri® is a registered trademark of Apple, Inc. Smart Way® is a registered trademark of the U.S. Environmental Protection Agency. Stitcher™ is a trademark of Stitcher™, Inc. TORSEN LSD® is a registered trademark of JTEKT TORSEN North America, Inc. SiriusXM® All Access Radio is a registered trademark of SiriusXM Radio, Inc. SiriusXM Traffic® and SiriusXM Travel Link® are registered trademarks of SiriusXM Radio, Inc. Added Security, Crosstrek, Forester and Outback are registered trademarks of Subaru of America, Inc. BRZ, EyeSight, Impreza, Lineartronic, Legacy, Subaru, SUBARU BOXER, WRX, STI and X-MODE are registered trademarks of Subaru Corporation. Confidence in Motion and SUBARU STARLINK are trademarks of Subaru Corporation.

Table of Contents

2-5	Getting Started
6-7	Instrument Panel
8-9	Gauges
10-11	Personalize
12-17	Controls
18-23	While Operating
24-25	Safety/In Case of Emergency
26-28	Additional Information

Remote Keyless Entry

1 Lock/Arm

- Press to lock all doors and trunk.
- If any of the doors or the trunk are not fully closed, five rapid chirps will sound and the hazard lights will flash to alert you that the doors or the trunk are not properly closed.
- To activate the vehicle finder function, press three times (within five seconds). If you are within 30 feet of the vehicle, the horn will sound one time and the hazard lights will flash three times.

2 Unlock/Disarm

- Press once to unlock the driver's door.
- Press twice (within five seconds) to unlock all doors.
- When the "Unlock/Disarm" button is pressed, the dome and map lights will illuminate if the dome light switch is in the middle position and the map light switch is in the "on" position.

3 Unlocking the Trunk

- Press to unlock the trunk.

4 Panic Alarm

- Press once and the horn will sound and the hazard lights will flash.
- Press any button on the remote to deactivate.



Keyless Access and Push-Button Start (if equipped)

By simply carrying the access key in your pocket, you can lock and unlock doors, open the trunk and start your car without ever having to take the key fob out of your pocket.



Seating

Power Driver's Seat (if equipped)

Do not adjust the seat while driving.

① Forward/Backward, Angle and Height

Move the switch toward the front or rear to move the seat forward or backward. Pull the switch up or push down on the front of the switch to adjust the angle of the seat cushion. Pulling the switch straight up or pushing the switch straight down will adjust the height of the entire seat cushion.

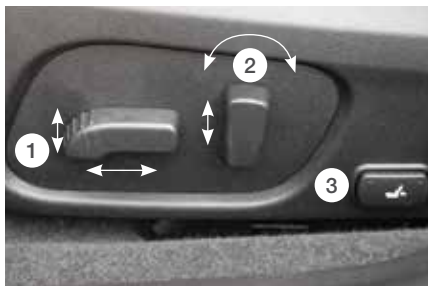

② Seatback

Move the switch in the corresponding direction to adjust the angle of the seatback.

③ Lumbar Support

Press the front part of the switch to increase lumbar support; press the rear part of the switch to decrease lumbar support.

Instrument Panel

Gauges

Personalize

Controls

While Operating

Safety/In Case of Emergency

Additional Information

Seating

Seat Controls

Do not adjust the seat while driving.

① Forward/Backward

Pull up on the lever below the front of the driver's seat to move the seat forward or backward.

② Raise/Lower Seat Cushion

To adjust the height of the driver's seat, pull up or push down the seat height adjustment lever, located on the lower left side front of the seat.

③ Recline Seatback

To adjust the seatback to the desired position, pull up on the recline lever, located on the lower left rear of the driver's seat or lower right rear of the passenger's seat.



Heated Seats (if equipped)

The switches are located on the center console between the driver and passenger seats. Choose low (bottom of switch) for normal heating or high (top of switch) for rapid heating. Choose the center position to turn off the seat heaters.



Folding the Rear Seats

Lower the headrests. Pull up on the release knob on the seat side that you want to fold down. To return the seatback to its original position, raise the seatback until it locks into place, making sure that it is securely locked.



Instrument Panel

Gauges

Personalize

Controls

While Operating

Safety/In Case of Emergency

Additional Information

Instrument Panel

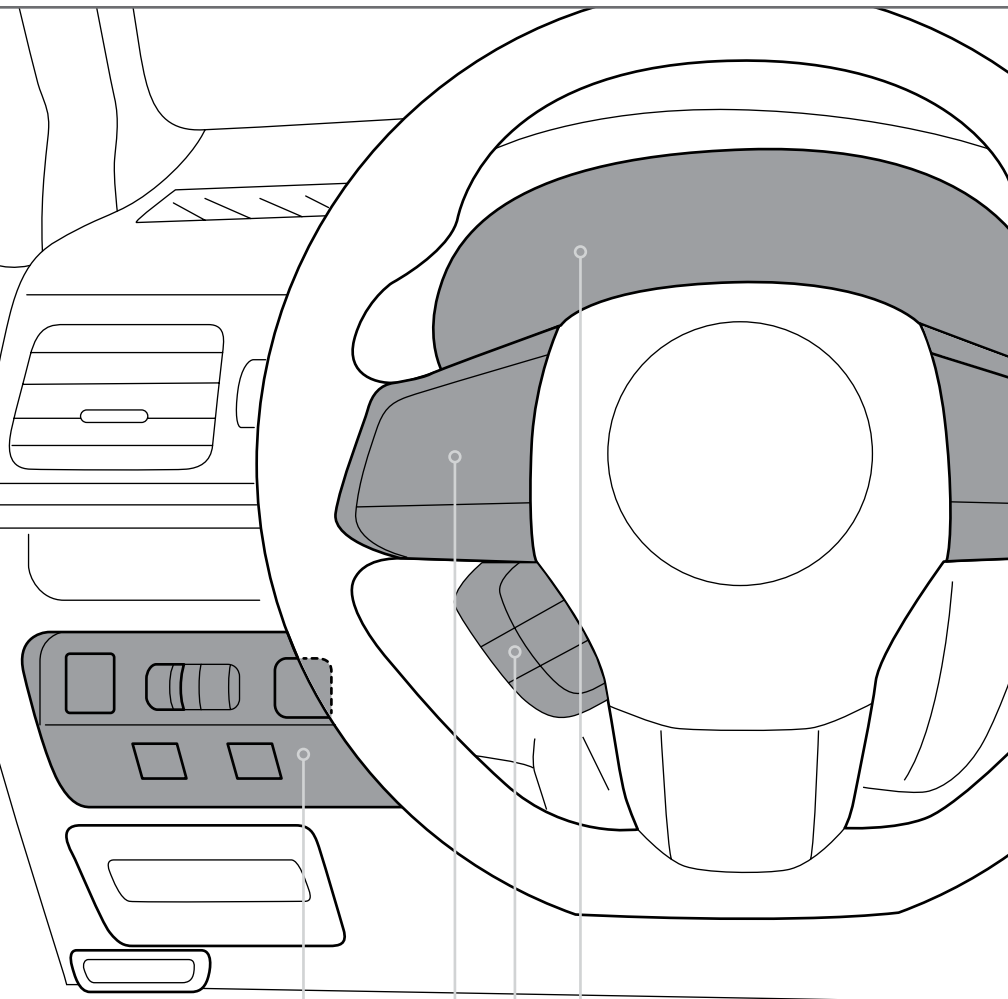

PAGE
NUMBER

12, 18

16

10

8-9

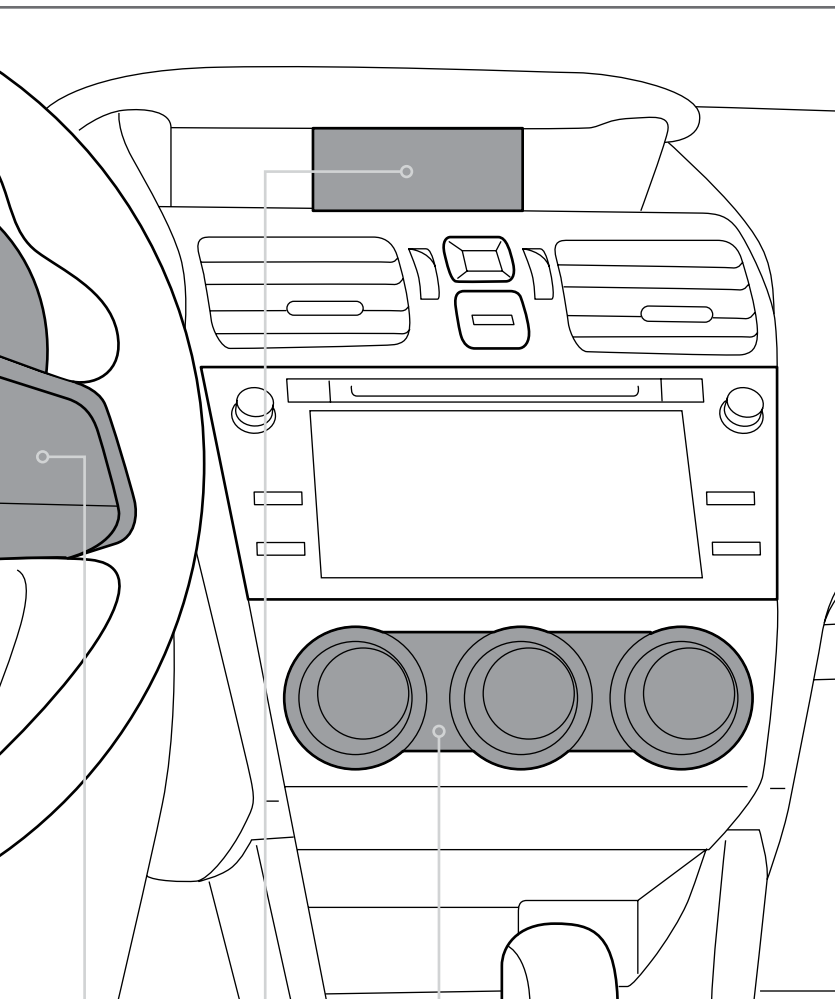

17

14-15

Clock

Use the multi-function display controls to set the time. Vehicles with a navigation system, please refer to the separate "Operating Instructions for Navigation System."

Gauges

- Immediate Attention
- Caution
- ■ Informational

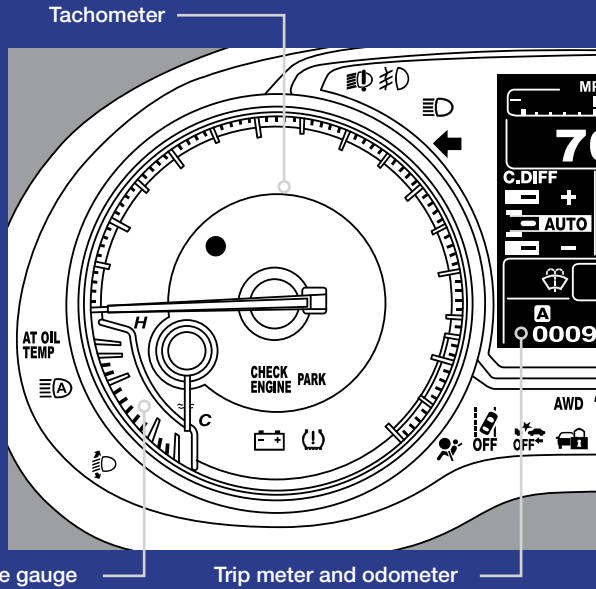

Seatbelt warning



Brake system



Front passenger seatbelt warning



High beam indicator light



SRS airbag system



AT OIL TEMP (Automatic Transmission)



Security indicator light



ABS warning



Door open



Low fuel



Charge warning



All-Wheel Drive (Automatic Transmission)



Oil pressure warning



Tire pressure warning light



Power steering warning



Headlight leveler (if equipped)

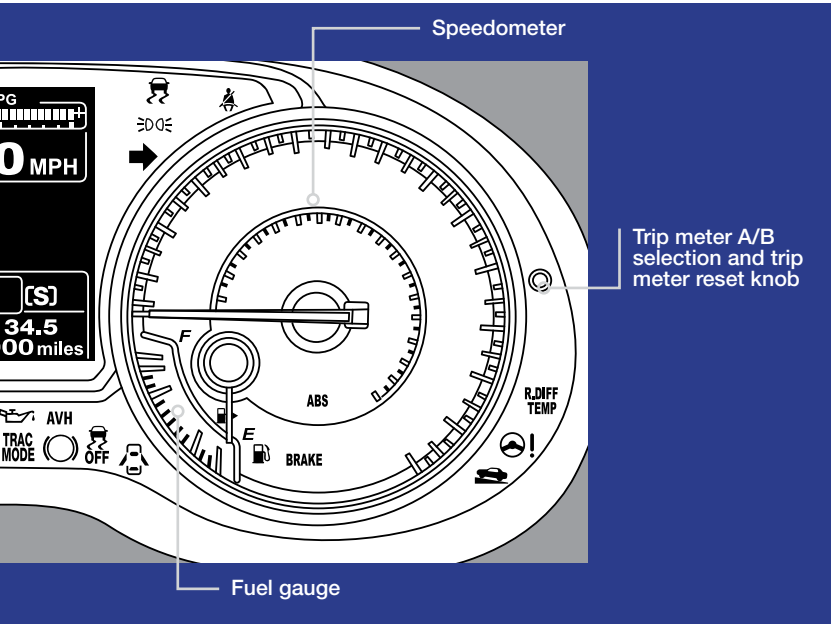

Vehicle Dynamics/Traction and Stability Control operation



Pre-Collision Braking System OFF light



Vehicle Dynamics Control OFF



Lane Departure Warning OFF light



CHECK ENGINE/
Malfunction indicator



Incline start assist (vehicles without Auto Vehicle Hold)



Tire pressure warning light



Auto Vehicle Hold ON



Front passenger airbag ON
(Located on overhead console)



Turn signals

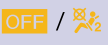

Front passenger airbag OFF
(Located on overhead console)



Front fog light indicator light
(if equipped)



Auto Vehicle Hold operation



Headlight indicator light



Rear Differential Oil
Temperature light

Personalize

Tilt and Telescopic Steering Column

Pull the lever down firmly to adjust the height and lengthwise position of the column; firmly push the lever back up to lock the column in place. Do not adjust while driving.



Power Exterior Mirrors

Turn the knob to the "L" side to adjust the left-hand mirror or to the "R" side to adjust the right-hand mirror. Move the knob in the direction you want to move the mirror. Then return the knob to the neutral/center position.



i/SET Combination Meter Display Controls

Use the i/SET controls to display and switch selected items in the Combination Meter Display located between the tachometer and speedometer. Please refer to your Owner's Manual for details on these controls.



Power Moonroof (if equipped)

With the moonroof in the fully closed position, press the switch (2) to tilt the rear of the moonroof up. Press and hold the switch (1) to lower the moonroof. Press the switch (4) to open the moonroof to the midway position; press it again to fully open it. Press the switch (3) to close the moonroof. To stop the moonroof in a midway position while opening or closing, momentarily press either switch (3) or (4).



HomeLink® 5 Accessory Mirror (if equipped)

The HomeLink 5 accessory mirror provides three buttons to replace up to three hand-held radio frequency remotes used to activate devices such as garage door openers, gate openers, entry door locks, security systems and home lighting. Please see your Owner's Manual for programming instructions or visit www.subaru.com/homelink to view a how-to video.



Controls

Light Controls

Push forward to change from low beam to high beam. Pull the lever back to center to return to low beam.

Turns on headlights, instrument panel illumination, parking lights, tail lights and license plate lights.

Push slightly up for lane change or fully up for right turn signal.

Push slightly down for lane change or fully down for left turn signal.

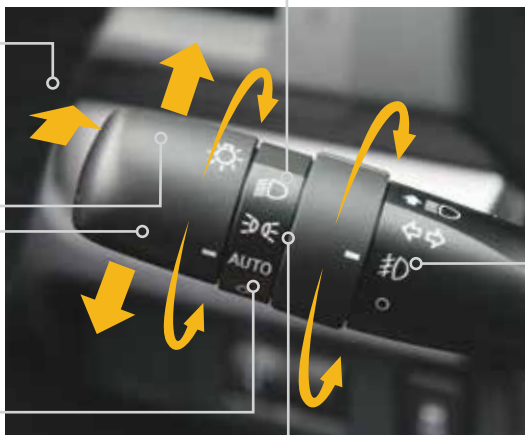

Rotate to turn on fog lights (if equipped).

AUTO (if equipped): The vehicle's lights are automatically on or off, depending on the level of outside light.

Turns on instrument panel lights, tail lights, parking lights and license plate lights.

While the light switch is on, rotate the dial downward to dim the instrument panel illumination. Rotate the dial upward to make the illumination brighter. When the dial is fully rotated upward (dots aligned), the instrument panel illumination stays at full brightness.





Windshield Wipers

To turn on the wipers, press the wiper control lever down one level for intermittent, two levels for low, or three levels for high speed. Return the lever to the "OFF" position to stop the wipers. For a single wipe, move the lever up. To spray washer fluid, pull and hold the lever toward you. Rotate the dial to adjust the intermittent wiper speed.

Daytime Running Lights

Daytime running lights are standard on your vehicle. Only the front daytime running lights will be automatically turned on when the engine has started, the parking brake is fully released and the light switch is in the "OFF" or "DOE" position. The brightness of the illumination of the high beam headlights is reduced by the daytime running light system. You must always switch on your headlights when it is dark outside by turning the light switch to the "☰" position or have the switch in the "AUTO" position (if equipped).

Controls



Automatic Climate Control System (WRX Only)

- 1 Automatic On and Off**

This system automatically controls outlet air temperature, fan speed, air flow distribution, air inlet control, and air conditioner compressor operation. Press "AUTO" to activate. Press "OFF" to turn off the system.
- 2 Temperature Control Dial**

Rotate the dial clockwise to increase the temperature or rotate the dial counterclockwise to decrease the temperature and maintain a comfortable climate within the driver and passenger compartment. The temperature is displayed digitally on the screen.

Operation in Manual Mode

- 3 Recirculated/Outside Air Button**

Press the air inlet selection button to prevent outside air from being drawn into the passenger compartment. Press the button again to allow outside air into the compartment. TO PREVENT WINDSHIELD FOGGING, DO NOT REMAIN IN THE RECIRCULATED MODE FOR AN EXTENDED PERIOD OF TIME.



Located in the multi-function display; top center of dash

- 4 Fan Speed Control Knob**

Rotate the fan speed control knob to select the desired fan speed.
- 5 Air Flow Mode Selection Dial**

Turn the "MODE" dial to select the desired air flow mode. The selected air flow mode – either ventilation, bi-level, heat or heat-defrost – is shown on the display.
- 6 Air Conditioner Button**

Press the "A/C" button to activate the air conditioning. Press it again to turn off the air conditioning.
- 7 Defroster Button**

Press the button to defrost or dehumidify the windshield and front door windows.
- 8 Rear Window Defogger Button**

Press the button to turn on the defogger. It will automatically shut off after about 15 minutes. If the window clears before that time, you can press the button again to turn it off. If equipped, the outside mirror defogger and windshield wiper deicer will also activate.



Located in the multi-function display; top center of dash

Dual Zone Automatic Climate Control System (WRX STI only)

- ① Automatic On and Off**
This system automatically controls outlet air temperature, fan speed, air flow distribution, air inlet control, and air conditioner compressor operation. Press “AUTO” to activate. Press “OFF” to turn off the system.
- ② Temperature Control Dial**
Rotate the dial clockwise to increase the temperature or rotate the dial counterclockwise to decrease the temperature and maintain a comfortable climate within the driver and passenger compartment. The temperature is displayed digitally on the screen.

Separate temperature settings can be adjusted for the driver's side and passenger's side.
- ③ Recirculated/Outside Air Button**
Press the air inlet selection button to prevent outside air from being drawn into the passenger compartment. Press the button again to allow outside air into the compartment.
TO PREVENT WINDSHIELD FOGGING, DO NOT REMAIN IN THE RECIRCULATED MODE FOR AN EXTENDED PERIOD OF TIME.
- ④ Fan Speed Control Knob**
Rotate the fan speed control knob to select the desired fan speed.
- ⑤ Air Flow Mode Selection Button**
Press the “MODE” button to select the desired air flow mode. The selected air flow mode – either ventilation, bi-level, heat or heat-defrost – is shown on the display.
- ⑥ Dual Button**
Press the “DUAL” button to activate or deactivate the dual mode. Dual mode makes it possible to have separate temperature settings for the driver's side and passenger's side.
- ⑦ Air Conditioner Button**
Press the “A/C” button to activate the air conditioning. Press it again to turn off the air conditioning.
- ⑧ Defroster Button**
Press the button to defrost or dehumidify the windshield and front door windows.
- ⑨ Rear Window Defogger Button**
Press the button to turn on the defogger. It will automatically shut off after about 15 minutes. If the window clears before that time, you can press the button again to turn it off. If equipped, the outside mirror defogger and windshield wiper deicer will also activate.

Controls

Steering Wheel Audio Controls

Push the top (+) of the switch to increase volume or the bottom (-) of the switch to decrease volume.

Press the button to show the list screen.

With any of the radio modes selected, push the switch left or right to toggle through your presets. In CD mode, push the switch left or right to skip forward or back a track.



Press the button to return to the previous screen.

Press the button to turn audio ON/OFF or to select the cursor entry.

Press the button to select the desired audio mode – FM, AM, SXM, CD, AUX, MEDIA.

Voice recognition switch; please refer to your Starlink Owner's Manual.

USB Port



The USB port is located in the center console. You can connect a USB-equipped portable music player to the USB port and hear the music stored on it through the vehicle speakers. Press the "SOURCE" button located on the audio system repeatedly until the USB mode is selected.



Auxiliary Input Jack

The 3.5mm auxiliary input jack is located in the center console. You can connect a portable music player to the auxiliary jack and hear the music stored on it through the vehicle speakers. Press the "SOURCE" button located on the audio system to select the auxiliary mode.

Cruise Control

To activate the cruise control, press the “” button. The indicator light on the instrument panel will turn on. To deactivate cruise control, press the “” button again.

To resume your speed after canceling, push the switch to the “RES” side.



To cancel the cruise control, push the brake pedal or press the “CANCEL” button. If you have a manual transmission, you can push in the clutch pedal.

SI-DRIVE (WRX only; if equipped): Press S#/I for Sport Sharp mode, S/I for Sport mode, or either button for Intelligent mode.

Press the accelerator pedal until your vehicle reaches the desired speed. Push the switch to the “SET” side and release. Ease off the accelerator pedal. Your vehicle will maintain the desired speed.

Increase Speed

Push up the “RES/SET” switch to the “RES” side; hold until your vehicle reaches the desired speed and release. To increase speed using the accelerator pedal, press the pedal until you reach the desired speed. Push down the “RES/SET” switch to the “SET” side to set the speed.

Decrease Speed

Push down the “RES/SET” switch to the “SET” side; hold until your vehicle slows to the desired speed and release. To decrease the speed using the brake pedal, press the pedal to release cruise control temporarily. When the speed decreases to the desired speed, push down the “RES/SET” switch to the “SET” side to set the speed.

While Operating



Instrument Panel Switches (lower left)

Please refer to your Owner's Manual for details on these switches.

- ① Traction Mode/Vehicle Dynamics Control OFF Switch
- ② Trunk lid opener switch

Paddle Shift Control Switches (if equipped)

- Temporary use: Even when the selector is in the “D” (Drive) position, you can temporarily shift the gear by pulling the “+” or “-” paddle shift control switch. The transmission will automatically switch back to Normal Mode.
- When the selector lever is in Manual Mode, shift to the next higher gear by pulling the “+” paddle shift control switch on the steering wheel. Pull the “-” paddle shift control switch to shift into the next lower gear.



Manual Shifting Operation

Arrow-shaped lights in the center of the instrument panel show whether an upshift is possible and whether a downshift is possible.



Automatic Transmission Shift Modes (if equipped)

The automatic transmission gives you vehicle control with two different driving modes: Normal Mode and Manual Mode.

Normal Mode

When the selector lever is in the “D” (Drive) position, the transmission is in Normal shift mode. The shift position indicator on the instrument panel shows “D”, and the transmission automatically shifts into a suitable forward gear.

Manual Mode

In Manual Mode, you select the desired gear position to obtain necessary acceleration and engine braking. Moving the selector lever left into the manual gate ① from the “D” (Drive) position causes the transmission to change into Manual Mode. To shift, use the paddle shift control switches. The shift position indicator shows the selected gear position.

While Operating

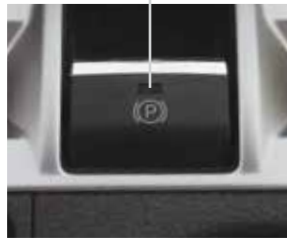

Auto Vehicle Hold Function (if equipped)

The Auto Vehicle Hold function will automatically keep the vehicle stopped even after releasing the brake pedal when the vehicle is stopped, such as at traffic signals. To activate, press the Auto Vehicle Hold switch. The Auto Vehicle Hold ON indicator light on the instrument panel will illuminate. To deactivate, press the switch again. While the Auto Vehicle Hold function is operating, the Auto Vehicle Hold operation indicator light on the instrument panel will illuminate.

Electronic Parking Brake (if equipped)

To apply, depress the brake pedal and pull up the parking brake switch. The brake system warning light on the instrument panel and the indicator light on the parking brake switch will illuminate.

To release, make sure all doors are closed and your seatbelt is fastened, then gently push the accelerator pedal. Or, while the ignition switch is in the ON position and the brake pedal is depressed, push down the parking brake switch.

REV Alarm System (WRX STI only)

The REV alarm system automatically issues a warning using the REV indicator light whenever the tachometer needle enters the red zone. This feature can be turned on or off using the multi-information display. The REV alarm level can be set manually to an engine speed of your choosing between 2,000 and 6,700 rpm using the multi-information display. The multi-information display is also used to select a warning alarm buzzer in addition to the light. Please refer to your Owner's Manual for more detailed instructions on setting the engine speed alarm level and selecting the warning buzzer.



6-Speed Manual Transmission

This manual transmission is a fully synchromeshed 6-forward and 1-reverse speed transmission. Before you can shift into reverse gear, you must raise the slider ring and hold it in that position. Only pull the slider ring up when shifting into reverse gear.



While Operating

Front Hood and Hood Scoop

Due to the lightweight material, a slight vibration is normal at higher speeds and will not affect the durability of the hood. To avoid deforming the front hood when closing, do not press down on the hood with your hands. You can release your hold on the front hood approximately 12 inches above the closing position and its weight should cause it to close securely.



Limited Slip Rear Differential (WRX STI only)

The Limited Slip Rear Differential provides optimum distribution of power according to the difference in revolution between the right and left rear wheels that may be caused by certain driving conditions, thereby improving driving stability on snow-covered, muddy or other slippery roads or during high-speed driving. Due to the nature of this mechanical Limited Slip Rear Differential, the differential gears may emit a vibration and/or noise when making turns. When servicing, use only specified gear oil.

SI-Drive (WRX STI only)

Turn the selector toward S for Sport mode or toward S# for Sport Sharp mode. Press down on the selector for Intelligent mode.



Driver Control Center Differential (DCCD) (WRX STI only)

This electronically controlled system adjusts the power-distribution ratio between the front and rear wheels. The system is designed to provide optimum differential control for improved vehicle cornering, stability, and handling control to suit driving and road surface conditions. The DCCD can be operated automatically or manually. When the system is in the automatic mode, the "AUTO" indicator light in the combination meter comes on. The DCCD can be taken out of "AUTO" mode and used manually by pressing the "AUTO MANU" switch located on the center console. Use the DCCD control switch located on the center console for manual operation.

Pressing the "AUTO MANU" switch again will return the system to "AUTO" mode. When using the system manually, if the control switch is set closer to or at the "Lock" position, the powertrain may make a vibration or noise when the vehicle is in tight turns at slow speeds (system binding). In addition, if the rear differential oil exceeds a certain temperature, the DCCD will automatically cancel the current torque-distribution ratio setting and adopt its minimum ratio.

Safety/In Case of Emergency



Child Restraint System

Your vehicle is equipped with Lower Anchors and Tethers for CHildren (LATCH). For maximum safety, first carefully read the LATCH system instructions from the device manufacturer, as well as the installation instructions in your Owner's Manual, to properly install the LATCH compatible restraint system. Use the appropriate seatbelts or anchorages provided in your vehicle. Children age 12 and under must properly occupy the rear seat at all times.

Child Safety Locks

The child safety locks are located on the inside edges of the rear doors. In the locked position, the rear doors can only be opened from the outside.



Internal Safety Trunk Release with Self-Illuminating Handle

In the event that children or adults become locked inside the trunk, this luminescent handle allows them to open the lid from inside the trunk. To open, simply pull the yellow handle downward as indicated by the arrow on the handle, and then push up on the lid.



Location of Spare Tire and Jack

A jack and other maintenance tools are stored in the tool bucket in the center of the spare tire, located in the trunk or cargo area.



Emergency Towing Your All-Wheel Drive Vehicle

Since Subaru Symmetrical All-Wheel Drive distributes engine power to all four wheels, improper towing will severely damage your AWD system. A flatbed truck is the only recommended way to properly transport your AWD vehicle. If towing is necessary, it is best done by your Subaru Retailer or a commercial towing service.

Subaru Roadside Assistance

Subaru Roadside Assistance is free and standard on your vehicle. Coverage is automatic; there are no forms to complete. Subaru Roadside Assistance is available anytime during the 3-year/36,000-mile Subaru Limited Warranty, whichever comes first.* A Subaru Roadside Assistance decal has been affixed to the driver's door window.

Subaru Roadside Assistance: 1-800-261-2155

Exclusions

Specifically excluded from Subaru Roadside Assistance coverage are service requests or claims resulting from: accidents, vandalism, acts of God, violation of any laws, misuse and abuse, or vehicle modifications not recommended by the manufacturer.

*See your Retailer for details.

Additional Information

Fuel

- For WRX, use premium unleaded gasoline with an octane rating of 91 AKI or higher. If 91 AKI fuel is not readily available, regular unleaded gasoline with an octane rating of 87 AKI or higher may be temporarily used. However, depending on your driving habits and conditions, you may notice a decrease in engine performance, fuel economy and slight engine vibration or knocking. Consult the Owner's Manual for more detailed information.
- For WRX STI, use premium unleaded gasoline with an octane rating of 93 AKI or higher. If 93 AKI fuel is not readily available in your area, premium unleaded gasoline with an octane rating of 91 AKI may be used with no detriment to engine durability or driveability. However, you may notice a slight decrease in maximum engine performance while using 91 AKI fuel. Consult the Owner's Manual for more detailed information.

Fuel Capacity

- 15.9 US gal (60 liters, 13.2 Imp gal)
- When the low fuel indicator light is displayed on the instrument panel, approximately 2.6 US gallons (10.0 liters, or 2.2 Imp gal) of fuel remain.
- If you have recently fueled your vehicle, the check engine light on the instrument panel may stay on due to a missing or loose fuel filler cap (the cap should be tightened until a click is heard).

Fuel Filler Lid Release

The fuel filler lid release is located on the floor to the left of the driver's seat. To open the fuel filler lid, pull the fuel filler lever up and release.



Engine Oil

Use only the following oils:

- 5W-30 synthetic, replacement interval 6,000 miles under normal driving conditions. No requirement at the first 3,000 miles.
- ILSAC GF-5, which can be identified with the ILSAC certification mark (Starburst mark).
- Or API classification SN with the words “RESOURCE CONSERVING”.

Engine Oil Capacity

- For WRX: 5.4 US qt (5.1 liters, 4.5 Imp qt)
- For WRX STI: 4.5 US qt (4.3 liters, 3.8 Imp qt)

Engine Compartment

Please refer to your Owner's Manual for more information.

WRX Engine



Note: Callouts apply to both engines.

- | | |
|--------------------------|---|
| ① Brake Fluid Reservoir | ⑥ Engine Coolant Reservoir |
| ② Main Fuse Box | ⑦ Radiator Cap |
| ③ Battery | ⑧ Engine Oil Dipstick |
| ④ Windshield Washer Tank | ⑨ Air Cleaner Element |
| ⑤ Engine Oil Filler Cap | ⑩ Power Steering Fluid Reservoir (WRX STI only) |

WRX STI Engine



One Subaru Drive
Camden, NJ 08103-9800



MSA5B1905A
Issued July 2018
Printed in USA 07/18

