

Forester

2017

Quick Reference Guide



Love. It's what makes a Subaru, a Subaru.

 **SUBARU**
Confidence in Motion

Complete U.S. specifications and illustrations may not have been available at time of publication. Specifications are based on the latest product information available at time of publication. Some images shown are for illustration purposes only. Some equipment shown may be optional at extra cost. Specific options may be available only in combination with other options. Specific combinations of equipment or features may vary from time to time and by geographic area. Certain accessories and equipment may not be available at the time of publication.

This Quick Reference Guide applies to all Forester models. Therefore, some explanations may be for equipment not installed on your vehicle. Subaru of America, Inc., reserves the right to change or discontinue at any time, without notice, prices, colors, materials, equipment, accessories, specifications, models and packages without incurring any obligation to make the same or similar changes on vehicles previously sold. Colors shown may vary due to reproduction process.

For detailed operating and safety information, please consult the Owner's Manual.

Subaru, Outback, Legacy, Forester, Impreza, WRX, WRX STI, BOXER, SI-DRIVE, Lineartronic, Alcantara, EyeSight, HD Radio, Aha Radio, and SiriusXM are registered trademarks. SUBARU STARLINK is a trademark of Fuji Heavy Industries, Ltd.

All rights reserved. Contents may not be reprinted or electronically reproduced in whole or in part without prior written approval of Subaru of America, Inc.

© 2016 Subaru of America, Inc.

Table of Contents

2-5	Getting Started
6-7	Instrument Panel
8-11	Gauges
12-13	Personalize
14-21	Controls
22-23	While Operating
24-25	Safety/In Case of Emergency
26-28	Additional Information

Remote Keyless Entry

1. Lock/Arm

- Press to lock all doors and the rear gate.
- If any of the doors or the rear gate are not fully closed, an electronic chirp will sound and the hazard lights will flash to alert you that the doors or the rear gate are not properly closed.
- To activate the vehicle finder function, press three times (within five seconds). If you are within 30 feet of the vehicle, the horn will sound one time and the hazard lights will flash three times.

2. Unlock/Disarm

- Press once to unlock the driver's door.
- Press twice (within five seconds) to unlock all doors.
- When the "Unlock/Disarm" button is pressed, the dome and map lights will illuminate if the dome light switch is in the middle position.

3. Unlocking the Rear Gate

- Press the button to unlock the rear gate.

4. Panic Alarm

- Press once and the horn will sound and the hazard lights will flash.
- Press any button on the remote to deactivate.



Keyless Access with Push-Button Start System (if equipped)

By simply carrying the access key in your pocket, you can lock and unlock doors, open the rear gate and start your car without ever having to take the key fob out of your pocket.



Seating

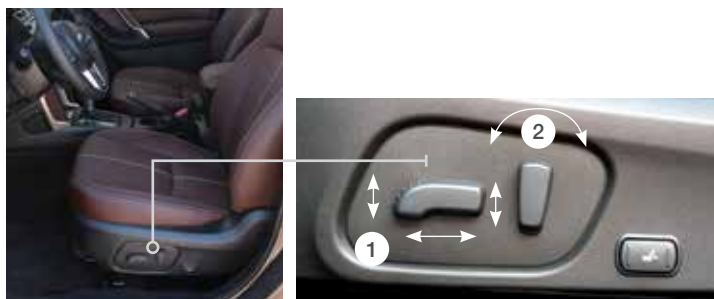

10-Way Power Driver's Seat (if equipped)

1. Forward/Backward, Angle and Height

Move the switch toward the front or rear to move the seat forward or backward. Pull the switch up or push down on the front of the switch to adjust the angle of the seat cushion. Pulling the switch straight up or pushing the switch straight down will adjust the height of the entire seat cushion.

2. Seatback

Move the switch in the corresponding direction to adjust the angle of the seatback.

3. Lumbar Support ³

Press the front part of the switch to increase lumbar support; press the rear part of the switch to decrease lumbar support.



Memory Driver's Seat (if equipped)

While pressing the "SET" button, press and hold the desired button "1" or "2". A beep sounds when the seat position is registered. Press button "1" or "2" to retrieve the seat positions.

Seating

Seat Controls

1. Forward/Backward

Pull up on the lever below the front of the driver's seat to move the seat forward or backward.

2. Raise/Lower Seat Cushion

To adjust the height of the driver's seat, pull up or push down the seat height adjustment lever, located on the lower left side front of the seat.

3. Recline Seatback

To adjust the seatback to the desired position, pull up on the recline lever, located on the lower left rear of the driver's seat or lower right rear of the passenger's seat. Do not adjust seats while driving.



Heated Seats (if equipped)

Press the switch in the corresponding direction for the desired seat temperature. To turn off the seat heater, slightly press in the opposite direction of the current position.



Folding the Rear Seat

Lower the headrests. Pull up on the release knob on the seat side that you want to fold down. To return the seatback to its original position, raise the seatback until it locks into place, making sure that it is securely locked.



Instrument Panel

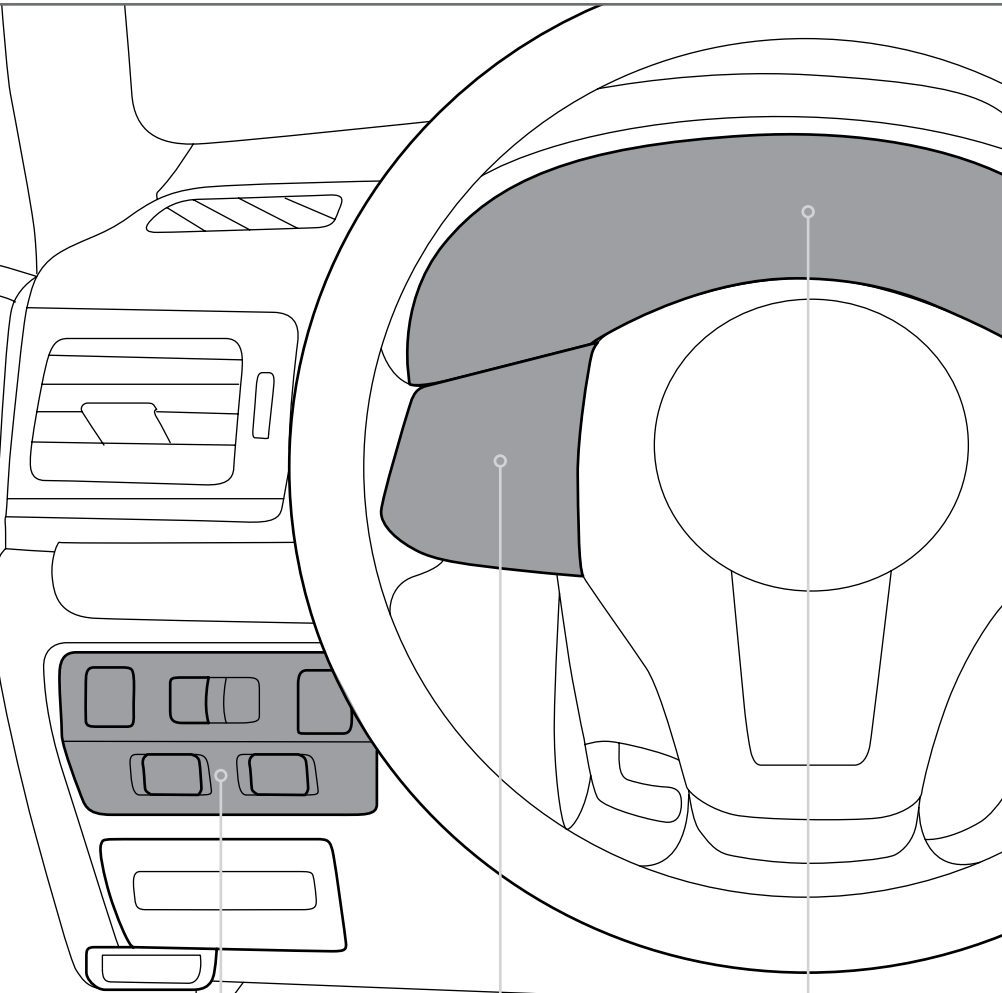

PAGE
NUMBER

14, 22

20

8-11

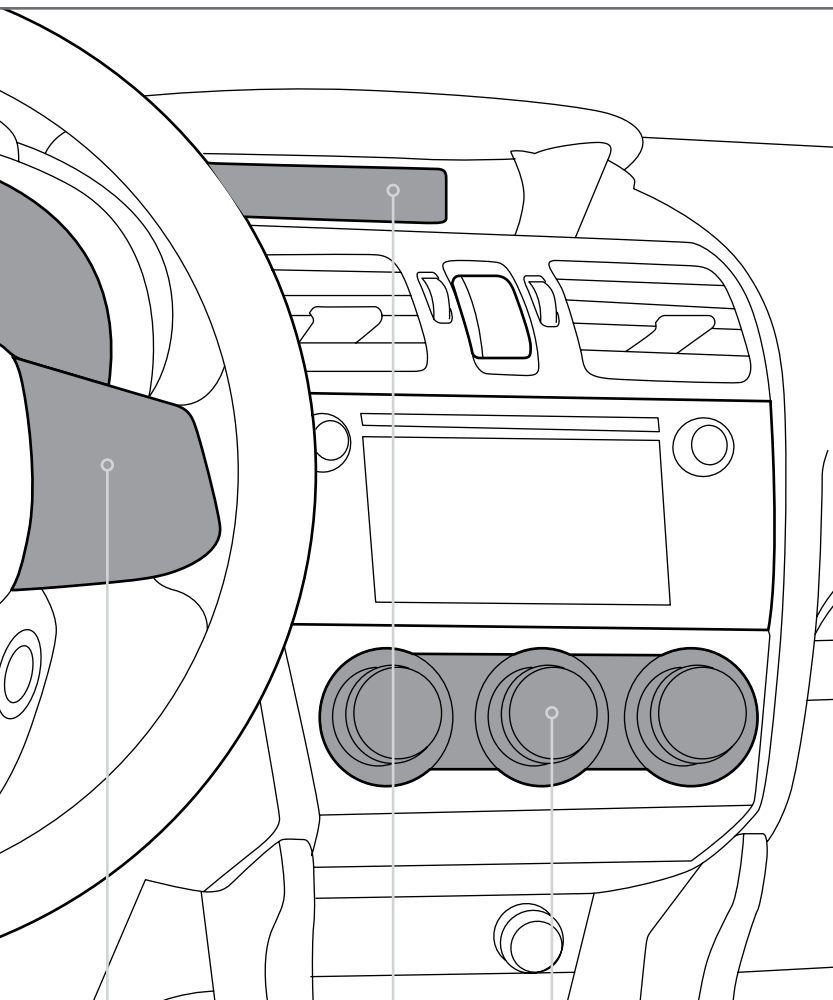

21

16-19

Clock

Press the "+" button to advance time or the "-" button to reverse the time. For vehicles with a navigation system, please refer to the separate "Operating Instructions for Navigation System."

Gauges

Forester 2.5i
Forester 2.5i Premium

- Immediate Attention
- Caution
- ■ Informational

Trip meter A/B
selection and trip
meter reset knob

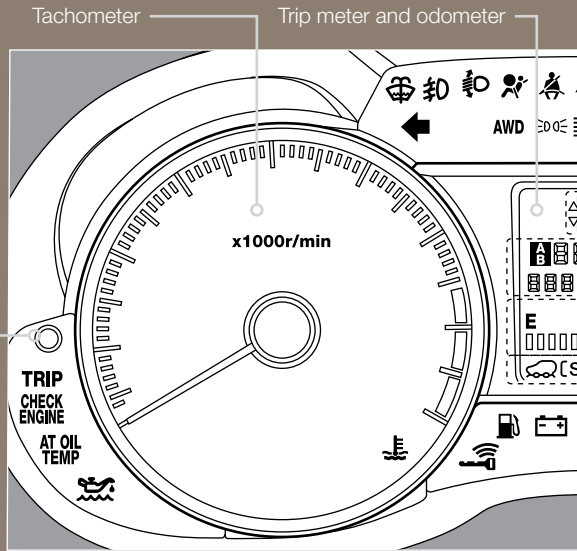

Seatbelt warning

BRAKE / Brake system



Front passenger
seatbelt warning



Hot coolant temperature /
Cold coolant temperature



SRS airbag system



High beam indicator light



Security indicator light



AT OIL
TEMP
AT OIL TEMP
(Automatic Transmission)



Door open



ABS / ABS warning



Charge warning



Low fuel



Oil pressure warning



All-Wheel Drive
(Automatic Transmission)



Power steering warning



Windshield washer
fluid warning

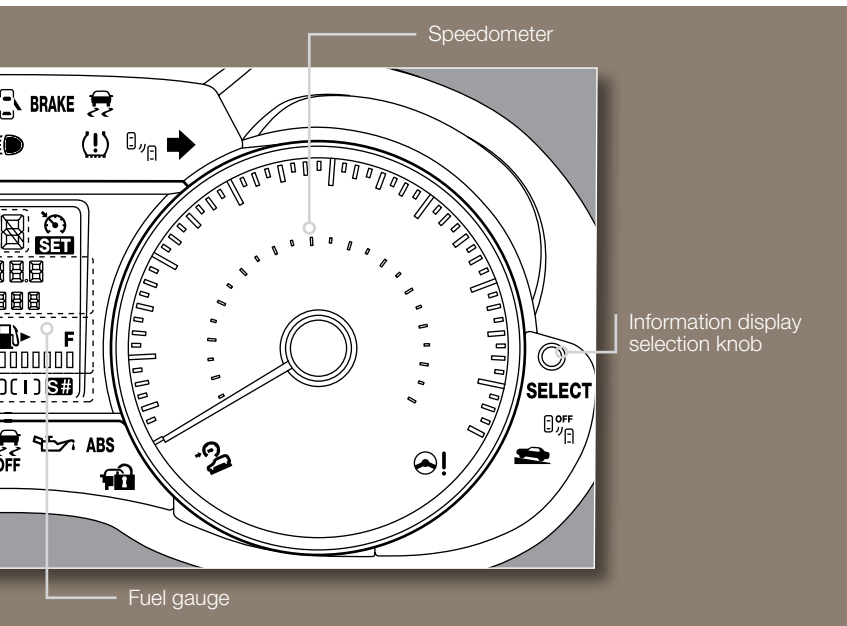

Vehicle Dynamics Control / Vehicle Dynamics Control operation



Keyless Access with Push Button Start System (if equipped)



Vehicle Dynamics Control OFF



Turn signals



CHECK ENGINE / Malfunction indicator



Front fog light indicator light (if equipped)



Tire pressure warning light



Headlight indicator light



Front passenger airbag ON (Located on overhead console)



Cruise control indicator light



Front passenger airbag OFF (Located on overhead console)



Cruise control set indicator light



Incline start assist



Engine oil level warning light

Gauges

Forester 2.5i Limited
 Forester 2.5i Touring
 Forester 2.0i XT Premium
 Forester 2.0i XT Touring

- Immediate Attention
- Caution
- ■ Informational

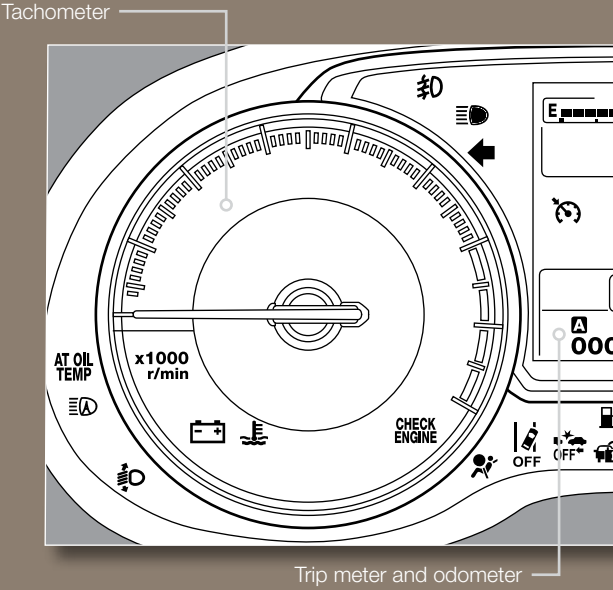

Seatbelt warning



Brake system



Front passenger seatbelt warning



Hot coolant temperature / Cold coolant temperature



SRS airbag system



High beam indicator light



Security indicator light



AT OIL TEMP (Automatic Transmission)



Door open



ABS warning



Charge warning



Low fuel



Oil pressure warning



All-Wheel Drive (Automatic Transmission)



Power steering warning



Headlight leveler (if equipped)

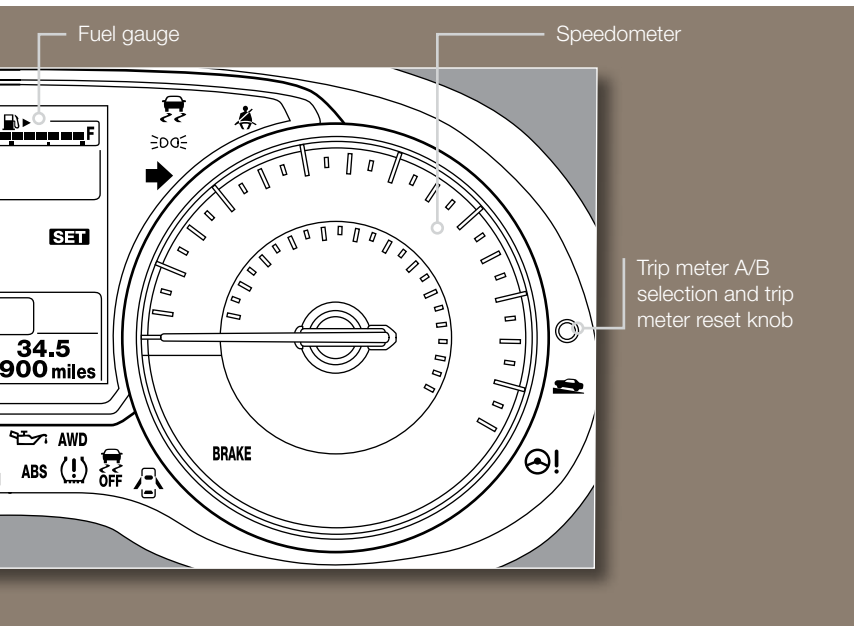

Vehicle Dynamics Control / Vehicle Dynamics Control operation



Windshield washer fluid warning



Vehicle Dynamics Control OFF



Keyless Access with Push Button Start System (if equipped)



CHECK ENGINE / Malfunction indicator



Turn signals



Tire pressure warning light



Front fog light indicator light (if equipped)



Front passenger airbag ON (Located on overhead console)



Headlight indicator light



Front passenger airbag OFF (Located on overhead console)



Cruise control indicator light



Incline start assist



Cruise control set indicator light



Engine oil level warning light



Hill descent control (if equipped)

Personalize

Tilt and Telescopic Steering Column

Push the lever down firmly to adjust the height and lengthwise position of the column; firmly push the lever back up to lock the column in place. Do not adjust while driving.



Power Exterior Mirrors

Turn the knob to the “L” side to adjust the left-hand mirror or to the “R” side to adjust the right-hand mirror. Move the knob in the direction you want to move the mirror. Then return the knob to the neutral/center position.



Heated Steering Wheel System (if equipped)



To activate, pull the Heated Steering Wheel switch while the ignition is in the ON position. The indicator light on the switch will illuminate.

To deactivate, pull the Heated Steering Wheel switch again.

Power Moonroof (if equipped)

With the moonroof in the fully closed position, press the switch ① to fully open the moonroof. Press the switch ② to close the moonroof. To stop the moonroof in a midway position while opening or closing, momentarily press the switch to the ① side or ② side.



Vehicles equipped with EyeSight



HomeLink® 5 Accessory Mirror (if equipped)

The HomeLink 5 accessory mirror provides three buttons to replace up to three hand-held radio frequency remotes used to activate devices such as garage door openers, gate openers, entry door locks, security systems and home lighting. Please see your Owner's Manual for programming instructions or visit www.subaru.com/homelink to view a how-to video.



Controls

Light Controls

Push forward to change from low beam to high beam. Pull the lever back to center to return to low beam.

Turns on headlights, instrument panel illumination, parking lights, tail lights and license plate lights.

Push up for right turn signal.

Push down for left turn signal.

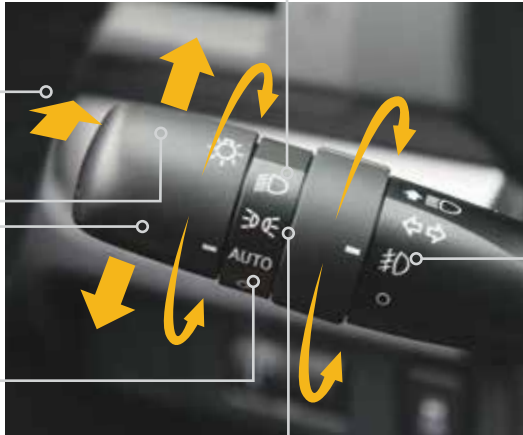

Turns on fog lights (if equipped).

AUTO (if equipped): The vehicle's lights are automatically on or off, depending on the level of outside light.

Turns on instrument panel lights, tail lights, parking lights and license plate lights.

While the light switch is on, rotate the dial downward to dim the instrument panel illumination. Rotate the dial upward to make the illumination brighter. When the dial is fully rotated upward, the instrument panel illumination becomes fully bright.





Windshield Wipers

To turn on the wipers, press the wiper control lever down one level for intermittent, two levels for low, or three levels for high speed. Return the lever to the "OFF" position to stop the wipers. For a single wipe, move the lever up. To spray washer fluid, pull and hold the lever toward you.

To operate the rear wiper, rotate the end of the knob upward to the intermittent, continuous, or wash position. When the rear wiper is off, rotate the knob downward to wash and wipe the rear window.

Daytime Running Lights

Daytime running lights are standard on your vehicle. Only a reduced brightness high beam will be automatically turned on when the engine has started, the parking brake is fully released and the light switch is in the "OFF" or "☰☑" position. The brightness of the illumination of the high beam headlights is reduced by the daytime running light system. You must always switch on your headlights when it is dark outside by turning the light switch to the "☰●" position.

Controls



Manual HVAC System (if equipped)

1. Temperature Control Dial

Rotate the temperature control dial from blue for cool, to red for warm.

2. Air Conditioning Button

Press the "A/C" button to activate the air conditioning. Press it again to turn off the air conditioning.

3. Recirculated/Outside Air Button

Press the air inlet selection button to prevent outside air from being drawn into the passenger compartment. If the button is pushed in, press it again to draw outside air into the compartment. TO PREVENT WINDSHIELD FOGGING, DO NOT REMAIN IN THE RECIRCULATED MODE FOR AN EXTENDED PERIOD OF TIME.

4. Fan Speed Control Dial

Rotate the fan speed control dial to select one of four fan speeds.

5. Rear Window Defogger Button

Press the rear window defogger button to turn on the defogger. The defogger will automatically shut off after about 15 minutes. If the window clears before that time, you can press the button again to turn it off.

6. Air Flow Control Dial

The air flow control dial allows you to choose the direction of air flow. Rotate the dial for the desired air flow position.

Defrost/Defog

To clear the windshield and front door windows of fog or frost, rotate the air flow control dial to the defrost position, set the temperature control to the red position, and set the fan speed control to the fastest speed.



Located in the multi-function display; top center of dash

Automatic Climate Control System (if equipped)

1. Automatic On and Off

This system automatically controls outlet air temperature, fan speed, air flow distribution, air inlet control, and air conditioner compressor operation. Press "AUTO" to activate. Press "OFF" to turn off the system.

2. Temperature Control Dial

Rotate the dial clockwise to increase the temperature or rotate the dial counterclockwise to decrease the temperature and maintain a comfortable climate within the driver and passenger compartment. The temperature is displayed digitally on the screen.

Operation in Manual Mode

3. Recirculated/Outside Air Button

Press the air inlet selection button to prevent outside air from being drawn into the passenger compartment. Press the button again to allow outside air into the compartment. TO PREVENT WINDSHIELD FOGGING, DO NOT REMAIN IN THE RECIRCULATED MODE FOR AN EXTENDED PERIOD OF TIME.

4. Fan Speed Control Knob

Rotate the fan speed control knob to select one of seven different fan speed positions.

5. Air Flow Mode Selection Dial

Turn the "MODE" dial to select the desired air flow mode. The selected air flow mode – either ventilation, bi-level, heat or heat-defrost – is shown on the display.

6. Air Conditioner Button

Press the "A/C" button to activate the air conditioning. Press it again to turn off the air conditioning.

7. Defroster Button

Press the button to defrost or dehumidify the windshield and front door windows.

8. Rear Window Defogger Button

Press the button to turn on the defogger. It will automatically shut off after about 15 minutes. If the window clears before that time, you can press the button again to turn it off.

Controls



Dual Zone Automatic Climate Control System (if equipped)

1. Automatic On and Off

This system automatically controls outlet air temperature, fan speed, air flow distribution, air inlet control, and air conditioner compressor operation. Press "AUTO" to activate. Press "OFF" to turn off the system.

2. Temperature Control Dial

Rotate the dial clockwise to increase the temperature or rotate the dial counterclockwise to decrease the temperature and maintain a comfortable climate within the driver and passenger compartment. The temperature is displayed digitally on the screen.

Separate temperature settings can be adjusted for the driver's side and passenger's side.

Operation in Manual Mode

3. Recirculated/Outside Air Button

Press the air inlet selection button to prevent outside air from being drawn into the passenger compartment. Press the button again to allow outside air into the compartment. TO PREVENT WINDSHIELD FOGGING, DO NOT REMAIN IN THE RECIRCULATED MODE FOR AN EXTENDED PERIOD OF TIME.

4. Fan Speed Control Knob

Rotate the fan speed control knob to select one of seven different fan speed positions.

5. Air Flow Mode Selection Button

Press the "MODE" button to select the desired air flow mode. The selected air flow mode – either ventilation, bi-level, heat or heat-defrost – is shown on the display.



Located in the multi-function display; top center of dash

6. Dual Button

Press the “DUAL” button to activate or deactivate the dual mode. Dual mode makes it possible to have separate temperature settings for the driver’s side and passenger’s side.

7. Air Conditioner Button

Press the “A/C” button to activate the air conditioning. Press it again to turn off the air conditioning.

8. Defroster Button

Press the button to defrost or dehumidify the windshield and front door windows.

9. Rear Window Defogger Button

Press the button to turn on the defogger. It will automatically shut off after about 15 minutes. If the window clears before that time, you can press the button again to turn it off.

Controls

Steering Wheel Audio Controls

Push the top (+) of the switch to increase or the bottom (-) of the switch to decrease volume.

With any of the radio modes selected, push the switch left or right to skip through your presets. In CD mode, push the switch left or right to skip forward or back a track.



Press the button to show the list screen.

Press the button to return to the previous screen.

Press the button to turn audio ON/OFF or to select the cursor entry.

Press the button to select the desired audio mode – FM, AM, SAT, CD, AUX, MEDIA.

Talk switch; please refer to the “Bluetooth audio” section in your Owner’s Manual.

USB Port

The USB port is located in the center console. You can connect a portable music player to the USB port and hear the music stored on it through the vehicle speakers. Press the “SOURCE” button located on the audio system repeatedly until the USB mode is selected.



Auxiliary Input Jack

The 3.5mm auxiliary input jack is located in the center console. You can connect a portable music player to the auxiliary jack and hear the



music stored on it through the vehicle speakers. Press the “SOURCE” button located on the audio system to select the auxiliary mode.

Cruise Control

To activate the cruise control, press the “” button. The indicator light on the instrument panel will turn on. To deactivate cruise control, press the “” button again.

To resume your speed after canceling, push the switch to the “RES” side.



To cancel the cruise control, push the brake pedal or press the “CANCEL” button. If you have a manual transmission, you can push in the clutch pedal.

Press the accelerator pedal until your vehicle reaches the desired speed. Push the switch to the “SET” side and release. Ease off the accelerator pedal. Your vehicle will maintain the desired speed.

Increase Speed

Push up the “RES/SET” switch to the “RES” side; hold until your vehicle reaches the desired speed and release. To increase speed using the accelerator pedal, press the pedal until you reach the desired speed. Push down the “RES/SET” switch to the “SET” side to set the speed.

Decrease Speed

Push down the “RES/SET” switch to the “SET” side; hold until your vehicle slows to the desired speed and release. To decrease the speed using the brake pedal, press the pedal to release cruise control temporarily. When the speed decreases to the desired speed, push down the “RES/SET” switch to the “SET” side to set the speed.

While Operating



Instrument Panel Switches (lower left)

Please refer to your Owner's Manual for details on these switches.

1. Steering Responsive Headlights OFF switch (if equipped)
2. Traction Mode / Vehicle Dynamics Control OFF switch
3. Blind Spot Detection / Rear Cross Traffic Alert OFF switch (if equipped)
4. Power rear gate switch (if equipped)
5. Rear gate memory switch (if equipped)

Paddle Shift Control Switches (if equipped)

- Temporary use: Even when the selector is in the “D” (Drive) position, you can temporarily shift the gear by pulling the “+” or “-” paddle shift control switch. The transmission will automatically switch back to Normal Mode.
- When the selector lever is in Manual Mode, shift to the next higher gear by pulling the “+” paddle shift control switch on the steering wheel. Pull the “-” paddle shift control switch to shift into the next lower gear.



When Manual Shifting Operation is Possible

- Arrow-shaped lights in the center of the instrument panel show whether an upshift is possible and whether a downshift is possible.



Automatic Transmission Shift Mode

The automatic transmission gives you ultimate control with two different driving modes: Normal Mode and Low Mode.

Normal Mode

When the selector lever is in the “D” (Drive) position, the transmission is in Normal shift mode. The shift position indicator on the instrument panel shows “D”, and the transmission automatically shifts into a suitable forward gear.

Low Mode

Low Mode is for using engine braking when going down hill, etc. Moving the selector lever left into the low gate ① from the “D” (Drive) position causes the transmission to change into Low Mode. The shift position indicator show “L” as the selected gear position.

Safety/In Case of Emergency



Child Restraint System

For maximum safety, first carefully read the LATCH system instructions from the device manufacturer, as well as the installation instructions in your Owner's Manual, to properly install the LATCH compatible restraint system. Use the appropriate seatbelts or anchorages provided in your vehicle. Children age 12 and under must properly occupy the rear seat at all times.

Child Safety Locks

The child safety locks are located on the inside edges of the rear doors. In the locked position, the rear doors can only be opened from the outside.





Location of Spare Tire and Jack

A jack and other maintenance tools are stored in the tool bucket in the center of the spare tire, located in the trunk or cargo area. Raise the center lid and remove the bucket from the center of the spare tire. Take the jack out of the bucket. The jack handle is stowed on the back of the center lid of the cargo area.

Emergency Towing Your All-Wheel Drive Vehicle

Since Subaru Symmetrical All-Wheel Drive distributes engine power to all four wheels, improper towing will severely damage your AWD system. A flatbed truck is the only recommended way to properly transport your AWD vehicle. If towing is necessary, it is best done by your Subaru retailer or a commercial towing service.

Subaru Roadside Assistance

Subaru Roadside Assistance is free and standard on every 2017 Subaru vehicle. Coverage is automatic; there are no forms to complete. Subaru Roadside Assistance is available anytime during the 3-year/36,000-mile Subaru Limited Warranty, whichever comes first.* A Subaru Roadside Assistance decal has been affixed to the driver's door window.

Subaru Roadside Assistance:
1-800-261-2155

Exclusions

Specifically excluded from Subaru Roadside Assistance coverage are service requests or claims resulting from: accidents, vandalism, acts of God, violation of any laws, misuse and abuse, or vehicle modifications not recommended by the manufacturer.

**See your retailer for details.*

Additional Information

Fuel

- 2.5 liter DOHC Non-turbo models use regular unleaded gasoline with an octane rating of 87 AKI or higher. Consult the Owner's Manual for more detailed information.
- 2.0 liter DOHC Turbo model's engine is designed to operate at maximum performance using unleaded gasoline with an octane rating of 93 AKI or higher. If 93 AKI fuel is not readily available, unleaded gasoline with an octane rating of 91 AKI or higher may be temporarily used. However, you may notice a slight decrease in maximum engine performance while using 91 AKI fuel.

Regular unleaded gasoline with an octane rating of 87 AKI or higher may also be used. Using regular unleaded gasoline will not be detrimental to engine durability, nor will it affect your warranty coverage. However, depending on your driving habits and conditions, you may notice a decrease in maximum engine performance, fuel economy or slight engine vibration or knocking. It is not recommended to use 87 AKI when towing. Consult the Owner's Manual for more detailed information.

Fuel Capacity

- 15.9 US gal (60 liters, 13.2 Imp gal)
- When the low fuel indicator light is displayed on the instrument panel, approximately 2.6 US gallons of fuel remain.
- If you have recently fueled your vehicle, the Check Engine light on the instrument panel may stay on due to a missing or loose fuel filler cap (the cap should be tightened until a click is heard).

Fuel Filler Lid Release

Located on the floor to the left of the driver's seat. To open the fuel filler lid, pull the fuel filler lever up and release.



Engine Oil

Use only the following oils:

- ILSAC GF-5, which can be identified with the ILSAC certification mark (Starburst mark).
- Or API classification SN with the words “RESOURCE CONSERVING”.
 - 2.5 liter DOHC Non-turbo models use 0W-20 synthetic, replacement interval 6,000 miles under normal driving conditions. No requirement at the first 3,000 miles.
 - 2.0 liter DOHC Turbo models use 5W-30 synthetic, replacement interval 6,000 miles under normal driving conditions. No requirement at the first 3,000 miles.

Engine Oil Capacity

- 2.5 liter DOHC Non-turbo models: 5.1 US qt (4.8 liters, 4.2 Imp qt)
- 2.0 liter DOHC Turbo models: 5.4 US qt (5.1 liters, 4.5 Imp qt)

Engine Compartment

Please refer to your Owner's Manual for more information.

2.5i Engine



Note: Callouts apply to both engines.

1. Air Cleaner Element
2. Engine Oil Dipstick
3. Radiator Cap
4. Engine Oil Filter
5. Engine Oil Filler Cap

6. Engine Coolant Reservoir
7. Windshield Washer Tank
8. Battery
9. Main Fuse Box
10. Brake Fluid Reservoir

2.0 XT Engine



Vehicle Delivery Checklist

Delivery Information

V.I.N. _____

Delivery Date _____

Owner(s) _____

Phone: _____

Email: _____

Registration & Appointment

MySubaru Enrolled

SUBARU STARLINK™ Registration Declined

1st Service Appointment Initiated

Manuals & Warranties

Review vehicle manuals & maintenance schedule

Review warranty information
(Basic, Powertrain, Tire, Wear Items & Adjustments)

Review Subaru Roadside Assistance 1 (800) 261-2155

Retailer Orientation

Parts & Service departments locations & hours

Service Advisor introduction and/or business card

Service appointment & Early Bird
drop-off procedures

Vehicle Condition

Exterior/Interior is clean and undamaged

Verify that all equipment, accessories and options
are present

Note any exceptions: _____

Steering Wheel & Instrument Panel

- Master and Valet Keys, Keyless Access System* operation, Push Button Start* and Remote Start*
- Tilt/Telescopic Steering Column Adjustments and Paddle Shift operation*
- Steering Wheel Controls
- Headlights, DRL, Parking Lights, Hazard Lights, Interior Lights, Fog Lights*, Autolights* and Welcome / Goodbye Lighting*
- Front & Rear* Wiper and Washer Controls
- Gauges, Warning Lights, Multi Function Display*, Information Display settings and Parking Brake operation

STARLINK Audio System, Bluetooth & Safety / Security

- Bluetooth - Pair owner's phone(s) & show operation (Download SUBARU STARLINK and MySubaru Apps*)
- STARLINK Audio and Navigation* system controls (Sources, Presets, List & Back buttons)

Safety, Comfort & Convenience

- All Wheel Drive System, Emergency towing of AWD, VDC, X-Mode* and Hill Holder* operation
- Rear Vision Camera
- All Weather Package operation - Heated Seats, Exterior Mirrors & Windshield Wiper De-icer
- Review operation of climate control system
- Power windows, locks, exterior mirrors, seat including Memory Function* and Power Moonroof* operation
- Hood Release and fluid reservoir locations
- Fuel Filler Door, Trunk Release, Rear Gate operation and location of Spare Tire*, Jack & Tools

Driver Assist Technology

- Subaru EyeSight™ System*, Steering Responsive Foglights* and Steering Responsive Headlights*
- Reverse Automatic Braking System*
- Blind Spot Detection*, Lane Change Assist* and Rear Cross Traffic Alert*
- High Beam Assist*

*If Applicable

Owner Signature(s) _____

Subaru Sales Consultant _____

Subaru Sales Manager _____

Subaru of America, Inc., Subaru Plaza,
P.O. Box 6000, Cherry Hill, NJ 08034-6000



MSA5B1702A
Issued June 2016
Printed in USA 06/16

