

Foreword

This supplement contains explanations and instructions for correctly operating the following systems.

- Audio and Visual System
- Handsfree System
- APPS

If your vehicle contains one of the systems above, be sure to check the contents of this supplement carefully.

If you transfer the ownership of the vehicle to another person, make sure that this supplement is provided with the Owner's Manual inside the vehicle.

The information, specifications and illustrations in this supplement are valid at the time of publication. Fuji Heavy Industries reserves the right to change the specifications and design without prior notice, with no obligation to perform the same or equivalent changes to vehicles sold in the past.

This Owner's Manual supplement applies to all models, and describes all devices, including manufacturer-installed options. This means that information may be included about devices that are not installed in your vehicle.



SUBARU

STARLINK

Subaru STARLINK is the “in-car connectivity system” available on select Subaru vehicles.

FUJI HEAVY INDUSTRIES LTD., TOKYO, JAPAN

 **SUBARU** is a registered trademark of FUJI HEAVY INDUSTRIES LTD.

© Copyright 2015 FUJI HEAVY INDUSTRIES LTD.

Table of contents

Antenna system	2	USB memory	50
FM reception	2	iPod	53
Installation of accessories.....	2	Bluetooth audio	57
Audio set	2	aha™ by HARMAN	61
Audio set	3	AUX	70
Basic information before use.....	4	Pandora® (if equipped).....	73
Initial screen	4	Bluetooth® settings	78
Loading and unloading a disc.....	4	Registering/connecting Bluetooth® device	78
Connecting and disconnecting a USB memory/ portable device	5	Setting Bluetooth details.....	81
Touch screen gestures	6	Phone operation (Hands-free system for cellular phones).....	84
Touch screen operation.....	6	Quick reference	84
Entering letters and numbers/list screen operation	7	Some basics.....	85
Screen adjustment	8	Calling on the Bluetooth phone.....	88
Other settings.....	9	Receiving on the Bluetooth phone.....	94
Basic operation	11	Talking on the Bluetooth phone.....	95
Some basics	11	Setup	97
Tips for operating the audio/visual system.....	17	Phone settings	97
Operating information.....	17	What to do if.....	100
Useful information.....	25	Troubleshooting.....	100
SiriusXM Data Service (if equipped)	25	Voice command system operation	104
STARLINK.....	27	Voice command system	104
Radio operation.....	30	Command list.....	107
AM/FM radio.....	30	Appendix	111
SiriusXM Satellite Radio (if equipped)	42	Certification.....	111
Media operation.....	47	Certification for the Hands-free system.....	112
CD	47	Certification for Mexico models.....	112

Antenna system

■ FM reception

Although FM is normally static free, reception can be affected by the surrounding area, atmospheric conditions, station strength and transmitter distance. Buildings or other obstructions may cause momentary static, flutter or station interference. If reception continues to be unsatisfactory, switch to a stronger station.

Installation of accessories

Always consult your SUBARU dealer before installing a citizen band radio or other transmitting device in your vehicle. Such devices may cause the electronic control system to malfunction if they are incorrectly installed or if they are not suited for the vehicle.

Audio set

NOTE

- If a cell phone is placed near the audio set, it may cause the audio set to emit noise when the phone receives calls. This noise does not indicate an audio set malfunction. Note that a cell phone should be placed as far as possible from the audio set.
- Some functions may not be available depending on the market and specifications of your vehicle.
- The images shown in this Owner's Manual are sample images. The actual images may vary depending on the market and specifications of your vehicle.

■ Audio set

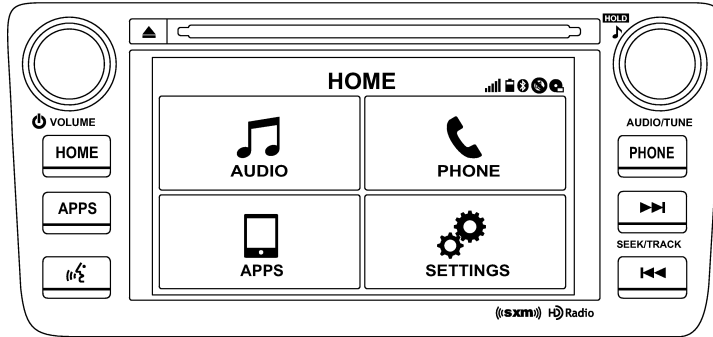

S02115

The audio set will operate only when the ignition switch is in the "ACC" or "ON" position.

NOTE

HD Radio Technology should be included as feature.

Basic information before use

■ Initial screen

▼ Initial screen

1. When the ignition switch is in the “ACC” or “ON” position, the initial screen will be displayed and the system will begin operating.



- When using the STARLINK function, the display screen may be different from the screen above.
- After a few seconds, the “Caution (Caution)” screen will be displayed.
- After about 5 seconds, the “Caution (Caution)” screen automatically switches to the next screen.

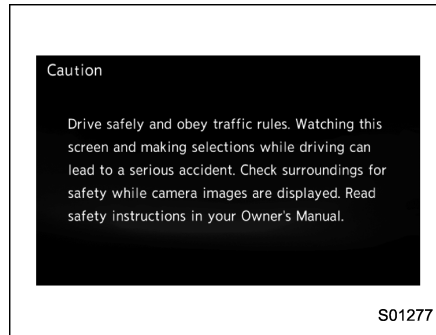

■ Loading and unloading a disc

▼ Loading a disc



1. Insert a disc into the disc slot.

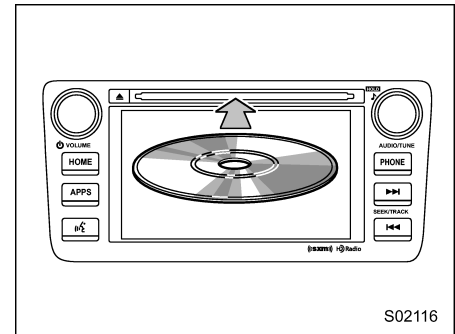

- After insertion, the disc is automatically loaded.

NOTE

- For compatible discs, refer to “CD player and disc” 18.
- When inserting a disc, gently insert it with the label facing up.

▼ Unloading a disc

1. Press  and remove the disc.

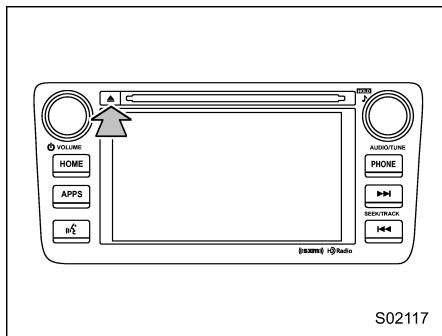

■ Connecting and disconnecting a USB memory/portable device

▼ Connecting a device

1. Open the center console and connect a device.

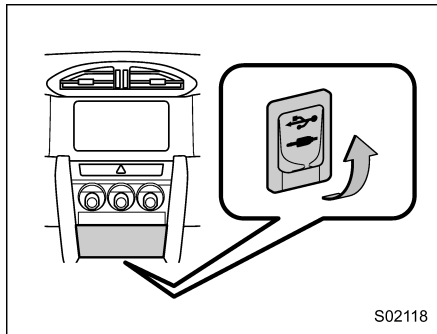

- Turn on the power of the device when it is not turned on.

NOTE

- This unit does not support commercially available USB hubs.
- This device has a USB port for USB memory/portable device.
- For compatible USB memory devices, refer to “USB memory device” 20.

- For compatible iPod models, refer to “iPod” 20.
- Even if a USB hub is used to connect more than two USB devices, only the last connected device will be recognized.

■ Touch screen gestures

Operations are performed by touching the touch screen directly with your finger.

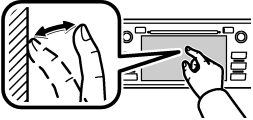
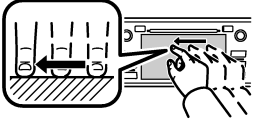
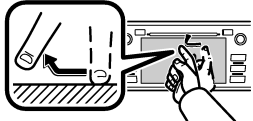
Operation method	Outline	Main use
	Touch Quickly touch and release once.	Changing and selecting various settings
	Drag* Touch the screen with your finger, and move the screen to the desired position.	Scrolling the lists
	Flick* Quickly move the screen by flicking with your finger.	Scrolling the main screen page

*: The above operations may not be performed on all screens.

NOTE

There may be a delayed response to flick operation that are performed at high altitudes.

■ Touch screen operation

This system is operated mainly by the buttons on the screen. (These are referred to as screen buttons in this manual.)

- When a screen button is touched, a beep sounds. (You can set the beep sound.) Refer to “Other settings” 9.



CAUTION

- To prevent damaging the screen, touch the screen buttons with your finger lightly.
- Do not use objects other than your finger to touch the screen.
- Wipe off fingerprints using a glass cleaning cloth. Do not use chemical cleaners to clean the screen, as they may damage the touch screen.

NOTE

- If the system does not respond to touching a screen button, move your finger away from the screen and touch

it again.

- Grayed-out screen buttons cannot be operated.
- The displayed image may become darker and moving images may be slightly distorted when the screen is cold.
- In extremely cold conditions, the screen may not be displayed correctly. Also, the screen keys may be less responsive than usual when pressed.
- When you look at the screen through polarized material such as polarized sunglasses, the screen may be dark and hard to see. If so, look at the screen from different angles, adjust the screen settings on the “Display Settings (Display Settings)” screen or take off your sunglasses.

■ Entering letters and numbers/list screen operation

▼ Entering letters and numbers

When entering the Bluetooth device name or PIN-code, or the phone number, letters and numbers can be entered via the screen.

In-Car-Device setting

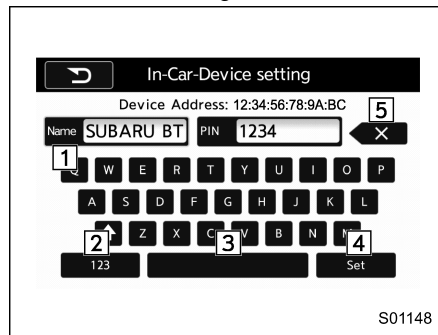

No.	Function
1	Enter the desired characters (alphabet key mode).
2	Display the number keys (change to number key mode).
3	Enter a space.
4	Set the characters/numbers entered into the window.
5	Delete a character/number entered into the window.

Dialpad



No.	Function
1	Enter the desired numbers.
2	Delete a number entered into the window.

▼ List screen

Two types of list are available on this device.

- Multimedia playlists
- Contacts list

Multimedia playlists (Example: iPod playlist)

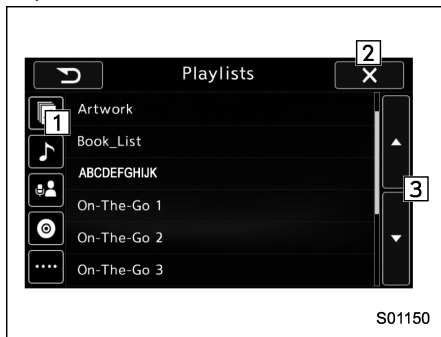

No.	Function
1	Graphic tab: Select a category that wants to play back.
2	Return to the playback display of each mode.
3	Select to skip to the next or previous page.

Contacts list (Example: phone book)

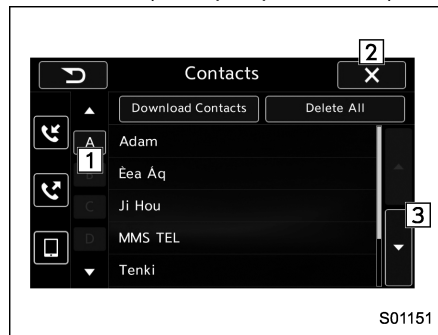

No.	Function
1	Alphabet button: Jump to list entries that begin with the same letter.
2	Return to the PHONE (Menu) screen.
3	Select to skip to the next or previous page.

■ Screen adjustment

The contrast and brightness of the screen display and the image of the camera display can be adjusted.

1. Select **HOME**.
2. Select **SETTINGS** (SETTINGS).
3. Select the items to be set.

In setting display, the Day/Night Mode and the Brightness can be changed.

SETTINGS display

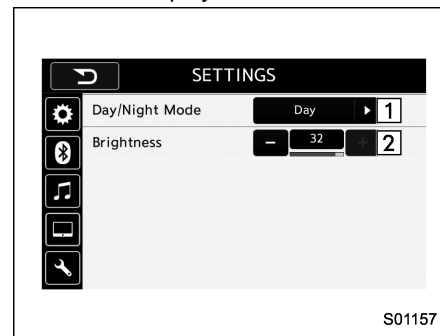

No.	Function
1	Select "Day/Night Mode". "Auto", "Day", or "Night" can be selected on the pop-up screen. When "Auto" is selected, the screen changes to day or night mode depending on the position of the headlight switch.
2	Select "Brightness". Press "+" or "-" to adjust the brightness.

NOTE

- When the screen is viewed through polarized sunglasses, a rainbow pattern may appear on the screen due to optical characteristics of the screen. If this is disruptive, please operate the screen without polarized sunglasses.
- If the screen is set to "Day" mode with the headlight switch turned on, this condition is memorized even with the engine turned off.
- When the vehicle is in motion, camera display cannot be adjusted.

In Camera display, the brightness, tint, color, and black level of the screen can be adjusted.

1. Set the selector lever in the R range.
2. Touch the items to be set after the rear camera monitor is displayed.

NOTE

The Camera display can be accessed when the rear camera monitor is displayed.

Camera display

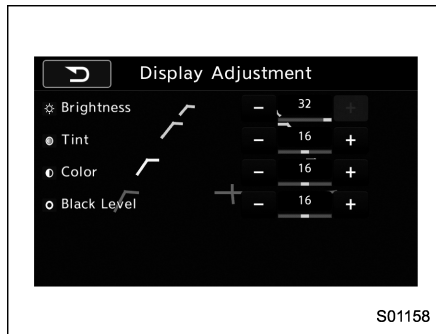

WARNING

When adjusting camera display screen, make sure to depress the brake pedal fully to avoid the vehicle from moving. Failure to do so may lead to a serious accident.

Other settings

1. Select **HOME**.

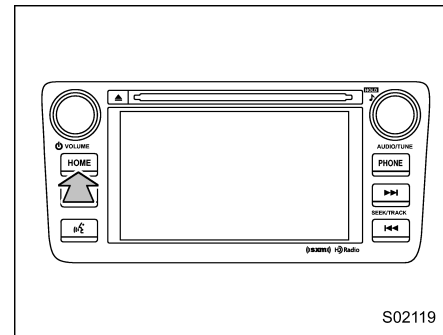

2. Select **SETTINGS** (SETTINGS).
3. Select the items to be set.

Gear wheel symbol tab

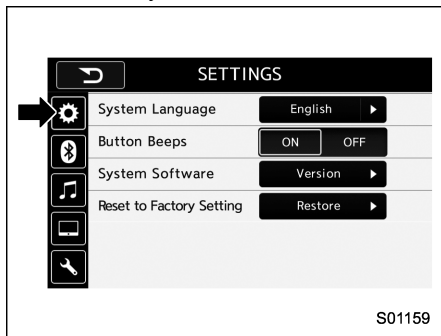

Item	Function
System Language	Select to change the language.
Button Beeps	Select to set the sound beeps on/off.
System Software	Select to update software versions. This menu is not used in usual operation.
Reset to Factory Setting	Select to reset the device to factory settings. This menu is not used in usual operation. When reset to factory setting, turn ignition off and on again.

Bluetooth symbol tab

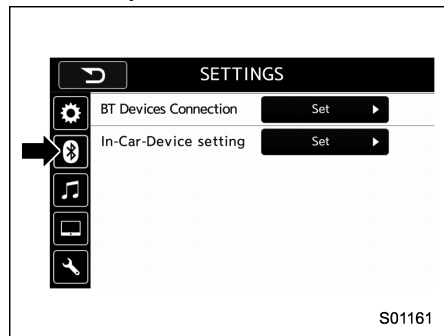

Item	Function
BT Devices Connection	Select to pair/connect the Bluetooth devices.
In-Car-Device setting	Select to enter the Bluetooth device name or PIN-code.

Note symbol tab

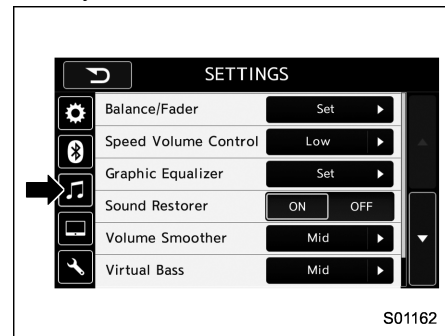

Item	Function
Balance/Fader	Select to adjust speaker volume balance (right/left and front/rear).
Speed Volume Control	Select to adjust speaker volume coupled to vehicle speed.
Graphic Equalizer	Select to adjust sound quality in each frequency band.
Sound Restorer	Select to add high-pitched tone to the compressed audio file.
Volume Smoother	Select to adjust volume difference between audio sources.
Virtual Bass	Select to add harmonic tone so that low-pitched tone is strengthened.

Item	Function
Vocal Image Control	Select to pick-up vocal sound signal from the sound data, and adjust it to left/right or front/rear.

Monitor symbol tab

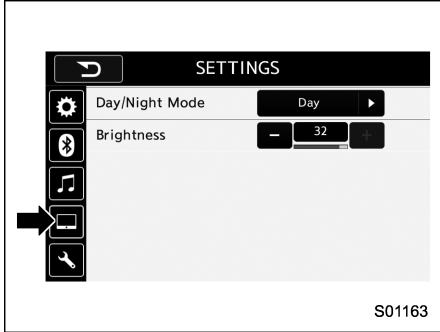

Item	Function
Day/Night Mode	Select "Day/Night Mode". "Auto", "Day", or "Night" can be selected on the pop-up screen. When "Auto" is selected, the screen changes to day or night mode depending on the position of the headlight switch.
Brightness	Select "Brightness".

Spanner symbol tab



Item	Function
Browser cache	Select to initialize cache files that the browser stores.

Basic operation

■ Some basics

This section describes some of the basic features of the audio/visual system. Some information may not pertain to your system.

Your audio/visual system works when the ignition switch is turned to the "ACC" or "ON" position.

CAUTION

To prevent the battery from being discharged, do not leave the audio/visual system on longer than necessary when the engine is not running.

▼ Turning the system on and off

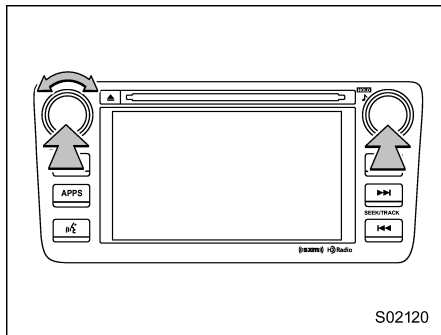

“**POWER/VOLUME**” knob: Press to turn the audio/visual system on and off. When the system turns on, the last mode is displayed. Press and hold the knob approx. 1.5 seconds or more, turn the display to off.

Turn this knob to adjust the volume.

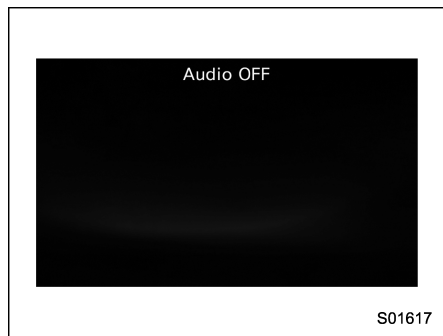

“**AUDIO/TUNE**” knob: Press to display screen buttons for the audio/visual system.

▼ Selecting an audio source

1. Press the “AUDIO/TUNE” knob.

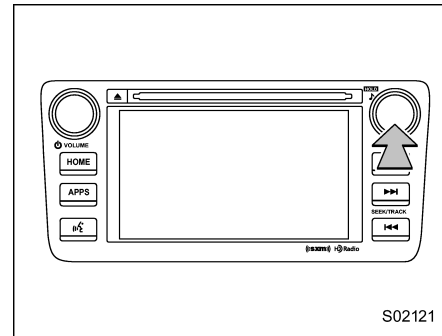

- The audio control screen can also be displayed by pressing HOME followed by “AUDIO”.

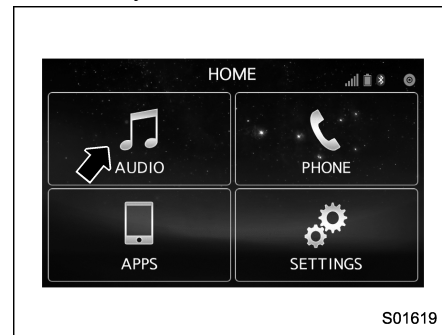

- If the audio control screen appears, select **Source** (Source) on the audio screen or press the “AUDIO/TUNE” knob again.
- Press the “AUDIO/TUNE” knob during lists are displayed, the audio play back screen appears. Press and hold the “AUDIO/TUNE” knob approx. 1.5 seconds or more, the graphic equalizer screen is displayed.

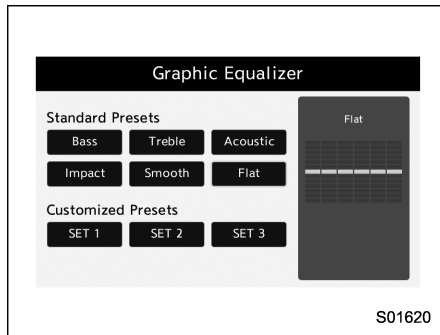

2. Select the desired source.

Source select display (for USA)

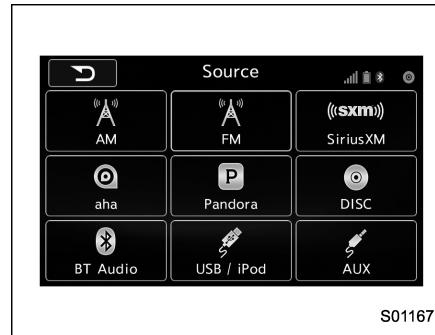

▼ Audio settings

1. Select **HOME**.
2. Select **SETTINGS** (SETTINGS).
3. Select the note symbol tab.
4. Select the desired item to be adjusted.

Setting ranges

Item	Step	Default
Audio volume	0-40	15
Balance	L9-R9	0 (Center)
Fader	F9-R9	0 (Center)
Vocal Image Control	Left/Right: R9-L9 Front/Rear: R9-F9	Left/Right: R3 Front/Rear: 0 (Center)
Speed Volume Control	OFF, Low, High	Low
Graphic Equalizer, SET1-3	-6--+6	0 (Flat)
Sound Restorer	ON, OFF	ON
Volume Smoother	OFF, Low, Mid, High	Mid
Virtual Bass	OFF, Low, Mid, High	Mid

▽ “Balance/Fader”

A good balance of the left and right stereo channels and of the front and rear sound levels is important for good quality audio program listening.

Keep in mind that when listening to a stereo recording or broadcast, changing the right/left balance will increase the volume of 1 group of sounds while decreasing the volume of another.

1. Touch the “Set” button of the Balance/Fader function.

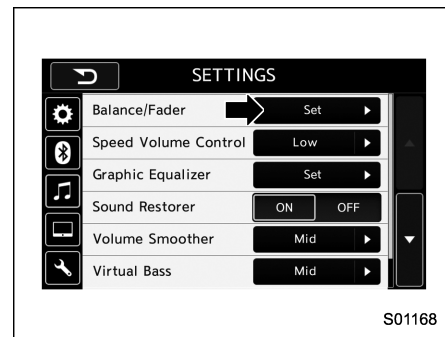

2. Select the “Volume Balance Control” menu.

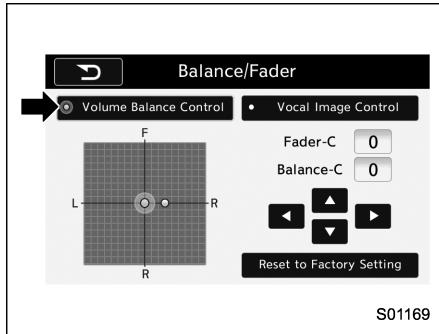

3. Adjust the balance by pressing “◀” or “▶” button.
4. Adjust the fader by pressing “▲” or “▼” button.
5. Select the “Vocal Image Control” menu.

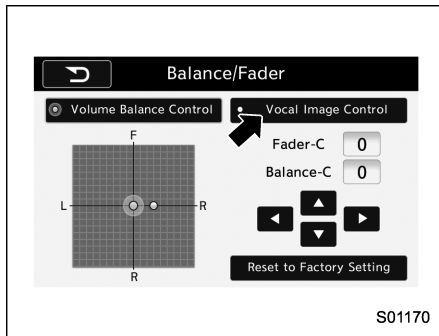

6. Adjust the balance by pressing “◀” or “▶” button.
7. Adjust the fader by pressing “▲” or “▼” button.

▽ “Speed Volume Control”

The system adjusts to the optimum volume and tone quality according to vehicle speed to compensate for increased vehicle noise.

1. Touch the right side button of the Speed Volume Control function, and select “OFF”, “Low”, or “High” menu. “High” comes to have a bigger effect.

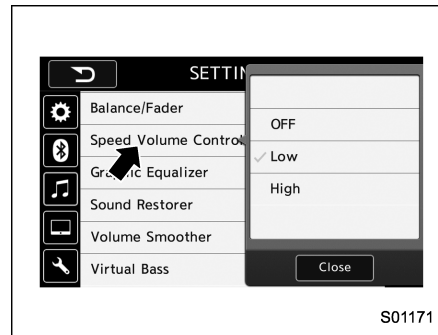

2. When select “OFF”, speed volume control function is cancelled.

▽ “Graphic Equalizer”

1. Touch the “Set” button of the Graphic Equalizer function.

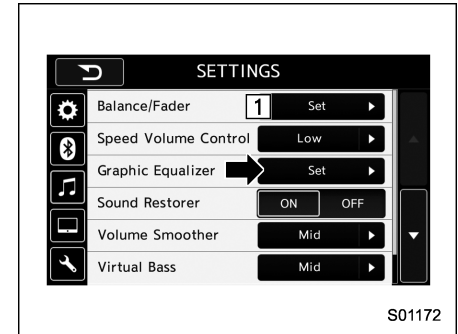

2. In this mode, 6 preset equalizer patterns and 3 customized patterns are available.

6 preset patterns: “Bass”, “Treble”, “Acoustic”, “Impact”, “Smooth”, “Flat”

3 customized patterns: “SET 1” - “SET 3”

3. When customizing the equalizer pattern, press one of SET button and then press “Adjust” button.

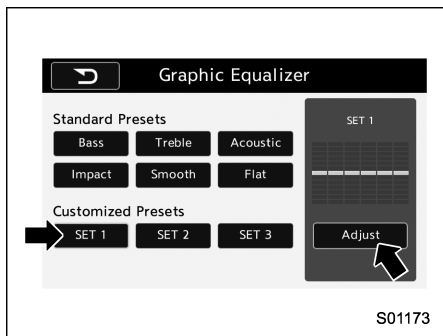

4. Adjust the level of each frequency band by pressing “▲” or “▼” button.

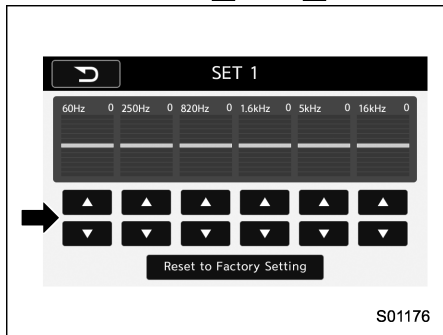

▽ “Sound Restorer”

Select “ON” or “OFF” by the right side button of the Sound Restorer function.

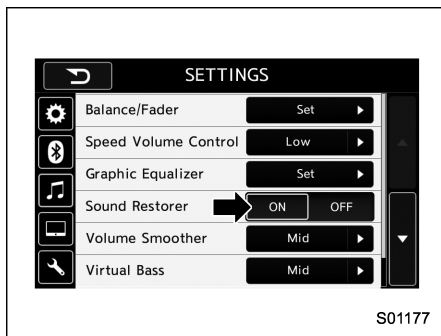

▽ “Volume Smoother”

1. Touch the right side button of the Volume Smoother function, and select “OFF”, “Low”, “Mid” or “High” menu. “High” comes to have a bigger effect.

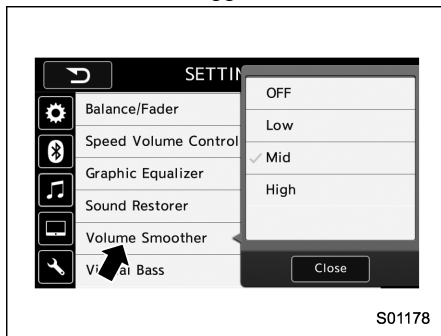

2. When select “OFF”, volume smoother function is cancelled.

▽ “Virtual Bass”

1. Touch the right side button of the Virtual Bass function, and select “OFF”, “Low”, “Mid” or “High” menu. “High” comes to have a bigger effect.

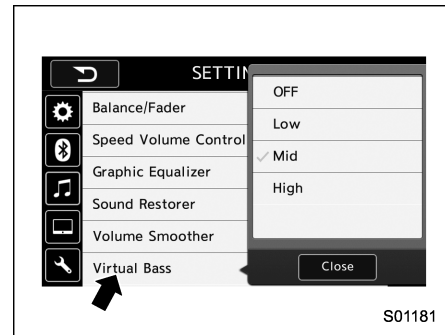

2. When select “OFF”, virtual bass function is cancelled.

▼ Voice command system

1. Press this button to operate the voice command system.

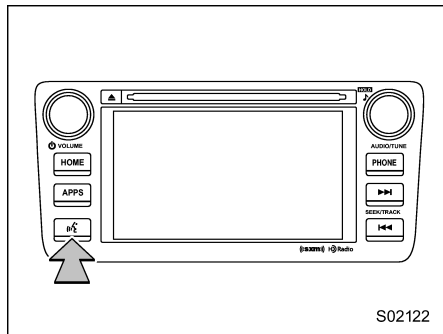

- The voice command system and its list of commands can be operated. Refer to “Voice command system operation” 104.

Tips for operating the audio/visual system

■ Operating information

⚠ CAUTION

- To avoid damage to the audio/visual system:
 - Be careful not to spill beverages over the audio/visual system.
 - Do not put anything other than an appropriate disc into the disc slot.

NOTE

The use of a cellular phone inside or near the vehicle may cause a noise from the speakers of the audio/visual system which you are listening to. However, this does not indicate a malfunction.

▼ Radio

Usually, a problem with radio reception does not mean there is a problem with the radio — it is just the normal result of conditions outside the vehicle.

For example, nearby buildings and terrain

can interfere with FM reception. Power lines or phone wires can interfere with AM signals. And of course, radio signals have a limited range. The farther the vehicle is from a station, the weaker its signal will be. In addition, reception conditions change constantly as the vehicle moves.

Here, some common reception problems that probably do not indicate a problem with the radio are described.

▽ FM

Fading and drifting stations: Generally, the effective range of FM is about 25 miles (40 km). Once outside this range, you may notice fading and drifting, which increase with the distance from the radio transmitter. They are often accompanied by distortion.

Static and fluttering: These occur when signals are blocked by buildings, trees or other large objects. Increasing the bass level may reduce static and fluttering.

Station swapping: If the FM signal being listened to is interrupted or weakened, and there is another strong station nearby on the FM band, the radio may tune in the second station until the original signal can be picked up again.

▽ AM

Fading: AM broadcasts are reflected by the upper atmosphere — especially at night. These reflected signals can interfere with those received directly from the radio station, causing the radio station to sound alternately strong and weak.

Station interference: When a reflected signal and a signal received directly from a radio station are very nearly the same frequency, they can interfere with each other, making it difficult to hear the broadcast.

Static: AM is easily affected by external sources of electrical noise, such as high tension power lines, lightning or electrical motors. This results in static.

▽ SiriusXM (if equipped)

- Cargo loaded on a roof luggage carrier, especially metal objects, may adversely affect the reception of SiriusXM Satellite Radio.
- Alternation or modifications carried out without appropriate authorization may invalidate the user's right to operate the equipment.

▼ CD player and disc

- This CD player is intended for use with 4.7 in. (12 cm) discs only.
- Extremely high temperatures can keep the CD player from working. On hot days, use the air conditioning system to cool the inside of the vehicle before using the player.
- Bumpy roads or other vibrations may make the CD player skip.
- If moisture gets into the CD player, the discs may not be able to be played. Remove the discs from the player and wait until it dries.



WARNING

CD players use an invisible laser beam which could cause hazardous radiation exposure if directed outside the unit. Be sure to operate the player correctly.

Audio CDs		

- Use only discs marked as shown above. The following products may not

be playable on your player:

- SACD
- dts CD
- Copy-protected CD
- Video CD

Special shaped discs

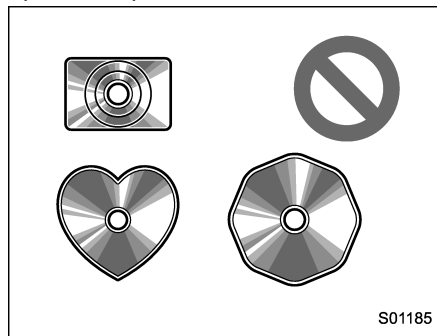

S01185

Transparent/translucent discs

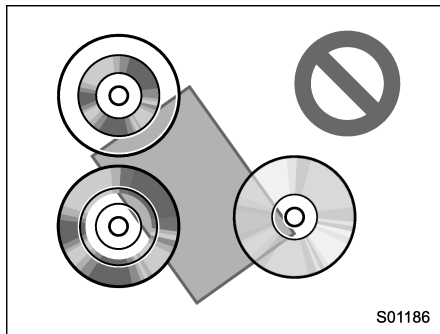

S01186

Low quality discs

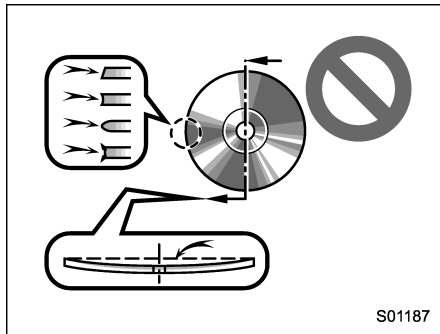

S01187

Labeled discs

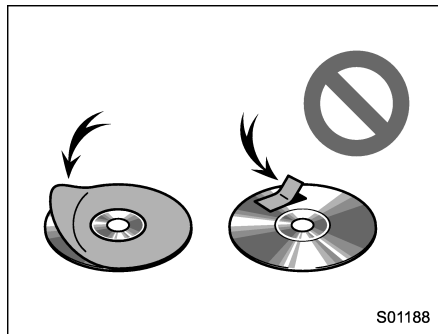

S01188

CAUTION

- Do not use special shaped, transparent/translucent, low quality or labeled discs such as those shown in the illustrations. The use of such discs may damage the player, or it may be impossible to eject the disc.
- This system is not designed for use of Dual Discs. Do not use Dual Discs because they may cause damage to the player.
- Do not use discs with a protection ring. The use of such discs may damage the player, or it may be impossible to eject the disc.

- Do not use printable discs. The use of such discs may damage the player, or it may be impossible to eject the disc.

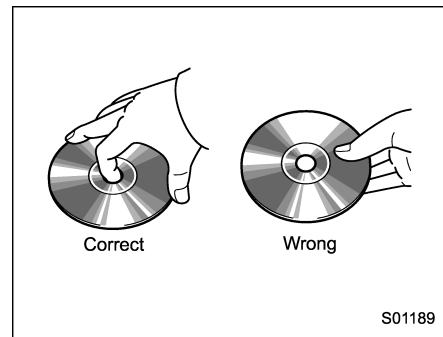

S01189

- Handle discs carefully, especially when inserting them. Hold them on the edge and do not bend them. Avoid getting fingerprints on them, particularly on the shiny side.
- Dirt, scratches, warping, pin holes or other disc damage could cause the player to skip or to repeat a section of a track. (To see a pin hole, hold the disc up to the light.)
- Remove discs from the players when not in use. Store them in their plastic cases away from moisture, heat and direct sunlight.

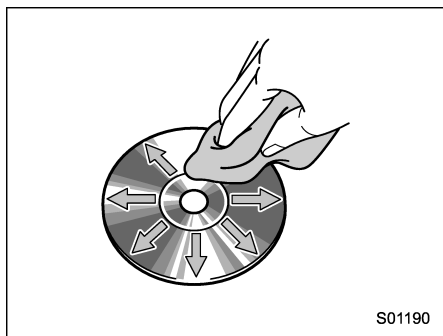

To clean a disc: Wipe it with a soft, lint-free cloth that has been dampened with water. Wipe in a straight line from the center to the edge of the disc (not in circles). Dry it with another soft, lint-free cloth. Do not use a conventional record cleaner or anti-static device.

▽ CD-R/RW discs

- CD-R/CD-RW discs that have not been subject to the “finalizing process” (a process that allows discs to be played on a conventional CD player) cannot be played.
- It may not be possible to play CD-R/CD-RW discs recorded on a music CD recorder or a personal computer because of disc characteristics, scratches or dirt on the disc, or dirt, condensation, etc. on the

lens of the unit.

- It may not be possible to play discs recorded on a personal computer depending on the application settings and the environment. Record with the correct format. (For details, contact the appropriate application manufacturers of the applications.)
- CD-R/CD-RW discs may be damaged by direct exposure to sunlight, high temperatures or other storage conditions. The unit may be unable to play some damaged discs.
- If you insert a CD-RW disc into the player, playback will begin more slowly than with a conventional CD or CD-R disc.
- Recordings on CD-R/CD-RW cannot be played using the DDCD (Double Density CD) system.

▼ USB memory device

- USB communication formats: USB 1.1/2.0 HS (480 Mbps) and FS (12 Mbps)
- File formats: FAT 16/32
- Correspondence class: Mass storage class

▼ iPod

The following iPod, iPod nano, iPod classic, iPod touch and iPhone devices can be used with this system.

Made for

- iPod touch (5th generation)*
- iPod touch (4th generation)
- iPod touch (3rd generation)
- iPod touch (2nd generation)
- iPod touch (1st generation)
- iPod classic
- iPod nano (7th generation)*
- iPod nano (6th generation)*
- iPod nano (5th generation)
- iPod nano (4th generation)
- iPod nano (3rd generation)
- iPod nano (2nd generation)*
- iPod nano (1st generation)*
- iPhone 5s*
- iPhone 5c*
- iPhone 5*
- iPhone 4s
- iPhone 4
- iPhone 3GS
- iPhone 3G
- iPhone

*: iPod video not supported

Depending on differences between models or software versions etc., some models might be incompatible with this system.

▼ File information

Compatible compressed files (Audio)

Item	USB	DISC
Compatible file format	MP3/WMA/AAC	
Folders in the device	Maximum 512	Maximum 255
Files in the device	Maximum 8000	Maximum 512
Files per folder	Maximum 255	—

Corresponding sampling frequency (Audio)

File type	Frequency (kHz)
MP3 files: MPEG 1 LAYER 3	32/44.1/48
MP3 files: MPEG 2 LSF LAYER 3	16/22.05/24
WMA files: Ver. 7, 8, 9 (9.1/9.2)	32/48/64/80/96/128/ 160/192
AAC files: MPEG4/AAC-LC	48/44.1/32/24/22.05/ 16/12/11.025/8

Corresponding bit rates (Audio)

File type	Bit rate (kbps)
MP3 files: MPEG 1 LAYER 3	32 - 320
MP3 files: MPEG 2 LSF LAYER 3	8 - 160
WMA files: Ver. 7, 8	CBR 48 - 192
WMA files: Ver. 9 (9.1/9.2)	CBR 32 - 192
AAC files: MPEG4/AAC-LC	16 - 320

(Variable Bit Rate (VBR) compatible)

- MP3 (MPEG Audio Layer 3), WMA (Windows Media Audio) and AAC (Advanced Audio Coding) are audio compression standards.
- This system can play MP3/WMA/AAC files on CD-R, CD-RW discs, USB memory, and Bluetooth device.
- This system can play disc recordings compatible with ISO 9660 level 1 and level 2 and with the Romeo and Joliet file system.
- When naming an MP3/WMA/AAC file, add an appropriate file extension (.mp3/.wma/.m4a).
- This system plays back files with .mp3/.wma/.m4a file extensions as MP3/WMA/AAC files respectively. To prevent noise

and playback errors, use the appropriate file extension.

- This system can play only the first session when using multi-session compatible CDs.
- MP3 files are compatible with the ID3 Tag Ver. 1.0, Ver. 1.1, Ver. 2.2 and Ver. 2.3 formats. This system cannot display disc title, track title and artist name in other formats.
- WMA/AAC files can contain a WMA/AAC tag that is used in the same way as an ID3 tag. WMA/AAC tags carry information such as track title and artist name.
- The emphasis function is available only when playing MP3/WMA files recorded at 32, 44.1 and 48 kHz.
- This system can play back AAC files encoded by iTunes.
- The sound quality of MP3/WMA files generally improves with higher bit rates. In order to achieve a reasonable level of sound quality, discs recorded with a bit rate of at least 128 kbps are recommended.
- The MP3/WMA player does not play back MP3/WMA files from discs recorded using packet write data transfer (UDF format). Discs should be recorded using “pre-mastering” software rather than “packet write” software.

- M3u playlists are not compatible with the audio device.
- MP3i (MP3 interactive) and MP3PRO formats are not compatible with the audio device.
- The player is compatible with VBR (Variable Bit Rate).
- When playing back files recorded as VBR (Variable Bit Rate) files, the play time will not be correctly displayed if the fast forward or reverse operations are used.
- It is not possible to check folders that do not include MP3/WMA/AAC files.
- MP3/WMA/AAC files in folders up to 8 levels deep can be played. However, the start of playback may be delayed when using discs containing numerous levels of folders. For this reason, we recommend creating discs with no more than 2 levels of folders.

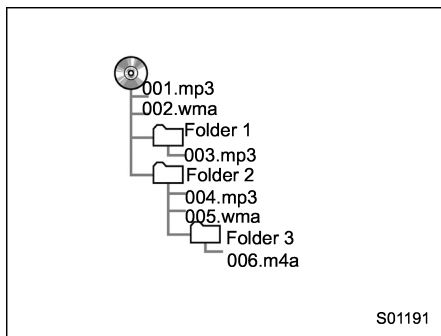

- The play order of the compact disc with the structure shown above is as follows:

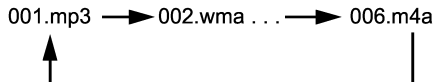

- The order changes depending on the personal computer and MP3/WMA/AAC encoding software you use.

▼ Terms

▽ Packet write

- This is a general term that describes the process of writing data on-demand to CD-R, etc., in the same way that data is written to floppy or hard discs.

▽ ID3 tag

- This is a method of embedding track-related information in an MP3 file. This embedded information can include the track number, track title, the artist's name, the album title, the music genre, the year of production, comments, cover art and other data. The contents can be freely edited using software with ID3 tag editing functions. Although the tags are restricted to a number of characters, the information can be viewed when the track is played back.

▽ WMA tag

- WMA files can contain a WMA tag that is used in the same way as an ID3 tag. WMA tags carry information such as track title and artist name.

▽ ISO 9660 format

- This is the international standard for the formatting of CD-ROM folders and files. For the ISO 9660 format, there are 2 levels of regulations.
 - Level 1: The file name is in 8.3 format (8 character file names, with a 3 character file extension. File names must be composed of one-byte capital letters and numbers. The “_” symbol may also be included.)

- Level 2: The file name can have up to 31 characters (including the separation mark “.” and file extension). Each folder must contain fewer than 8 hierarchies.

▽ MP3

- MP3 is an audio compression standard determined by a working group (MPEG) of the ISO (International Standard Organization). MP3 compresses audio data to about 1/10 the size of that on conventional discs.

▽ WMA

- WMA (Windows Media Audio) is an audio compression format developed by Microsoft®. It compresses files into a size smaller than that of MP3 files. The decoding formats for WMA files are Ver. 7, 8 and 9.
- This product is protected by certain intellectual property rights of Microsoft Corporation and third parties. Use or distribution of such technology outside of this product is prohibited without a license from Microsoft or an authorized Microsoft subsidiary and third parties.

▽ AAC

- AAC is short for Advanced Audio Coding and refers to an audio compression technology standard used with

MPEG2 and MPEG4.

▼ Error messages

Mode	Message	Explanation
CD	"Disc read error."	<ul style="list-style-type: none"> This indicates that no MP3/WMA/AAC files are included in the disc. This indicates that the disc is dirty, damaged, or it was inserted upside down. Clean the disc or insert it correctly. It indicates a disc which is not playable is inserted.
	"Please eject disc."	There is a trouble inside the system. Eject the disc.
USB	"Media not connected. Press AUDIO/TUNE knob to exit."	This indicates a problem in the USB memory or its connection. Refer to "Connecting and disconnecting a USB memory/portable device"  5.
	"No audio file."	This indicates that no MP3/WMA/AAC files are included in the USB memory.
	"Unplayable file"	This indicates that the accessed file cannot play back.
iPod	"Media not connected"	This indicates that a USB device/iPod is not connected to the system.
	"No audio file"	This indicates that there is no audio file in the connected iPod.
	"Unplayable file"	This indicates that the accessed file cannot play back.

NOTE

If the malfunction is not rectified: Take your vehicle to your SUBARU dealer.

Useful information

■ SiriusXM Data Service (if equipped)

Data service information, which is comprised of traffic information and weather information, can be received via the SiriusXM Radio.

To receive the data service information in the vehicle, a subscription to the SiriusXM Satellite Radio service is necessary. Refer to "SiriusXM Satellite Radio" 42.

Content set to use the SiriusXM data service is reset when personal information is initialized.

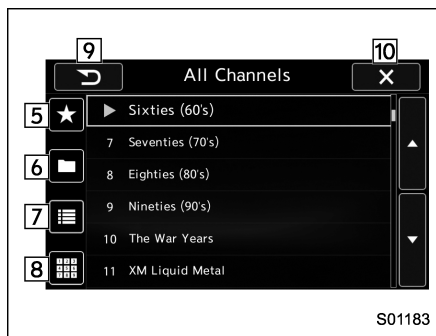
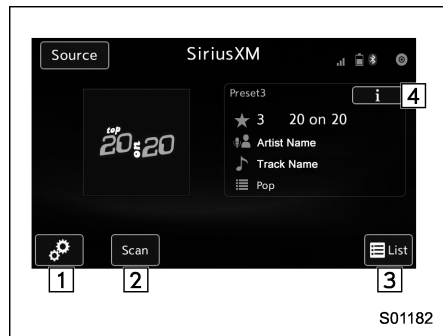

No.	Function
1	Option key: Perform the SXM setting. See below.
2	Scan key: Search for a channel which the direction of higher frequency from current frequency. Reproduce the channel that can receive by five seconds.
3	List key: A list is displayed. There are three types of lists ("Presets", "Categories", or "All Channels") are available. "Presets": Preset channels are displayed in a list. "Categories": The channels of the selected category are displayed in a list. "All Channels": All selectable channels are displayed in a list.
4	Info key: Display the contents information of a channel receiving.

No.	Function
5	Presets tab: Presets list (30 channels max.) is displayed.
6	Categories tab: Categories list is displayed.
7	All Channels tab: All channels list is displayed.
8	Direct Tune tab: Change to the Direct Tune display. See below.
9	Return to the previous display.
10	Return to the playback display.

▼ SXM setting option

1. A option menu screen is displayed when touch the Option key.

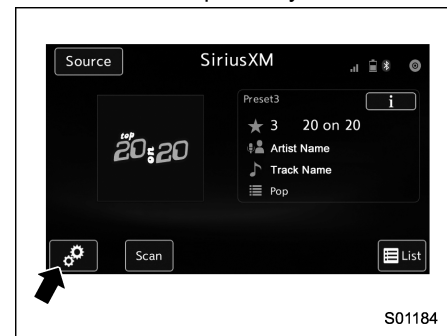

Option menu screen

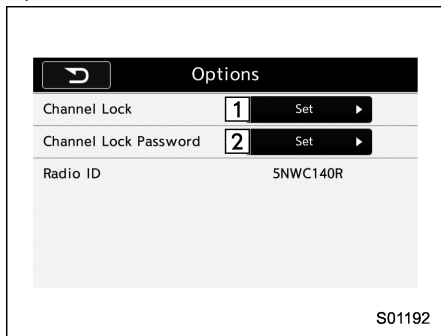

No.	Function
1	Channel Lock: Set the lock function of each channel. Input the password is necessary for operation.
2	Channel Lock Password: Set the password of the lock function.

2. A password input screen is displayed when touch the “Set” button of the Channel Lock function.

Password input screen

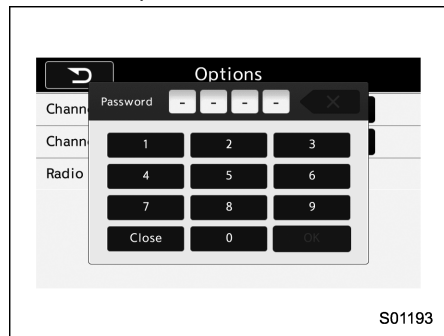

3. When the input password is approved, change to the lock channel selection screen.

Lock channel selection screen

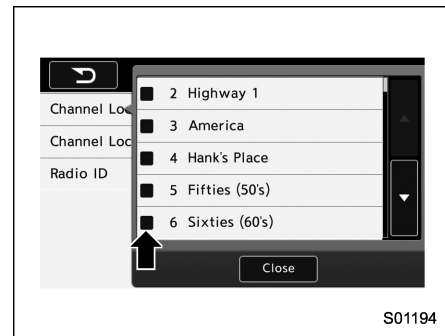

4. In the channel list, touch the channel that should be locked.

▼ Direct Tune

1. A channel input screen is displayed when touch the Direct Tune tab.

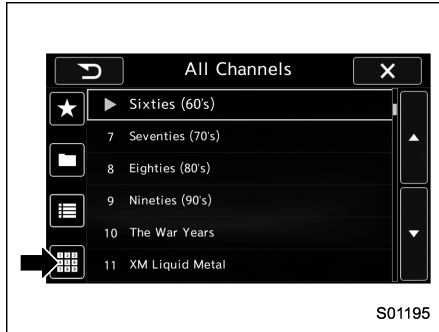

2. Input any number and press OK, receive the channel which input.

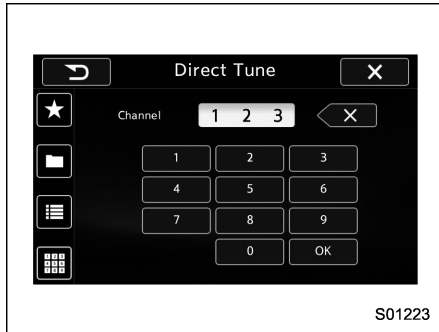

■ STARLINK

The STARLINK function allows the system to link with a smartphone using Bluetooth.

▼ Displaying STARLINK information

1. Press APPS key on the home screen, or press APPS button, the APPS screen is displayed.

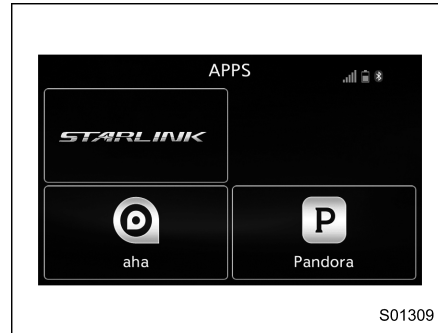

2. If you press "STARLINK" on the APPS screen, the STARLINK disclaimer screen or the error screen is displayed.

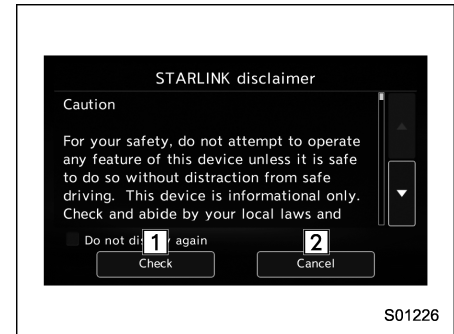

No.	Function
1	Check: Go to APPS screen.
2	Cancel: STARLINK disclaimer screen is disappeared and return to the previous screen.

STARLINK disclaimer error screen

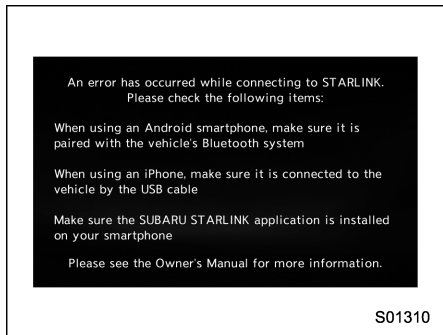

The error screen will be displayed due to one of the following possible reasons.

- Your smartphone and the system has not been connected via USB (for iPhone) or Bluetooth (for Android).
 - STARLINK APPS has not been activated.
3. If you press **Check** (Check) on the STARLINK disclaimer screen, the APPS main screen will be displayed.

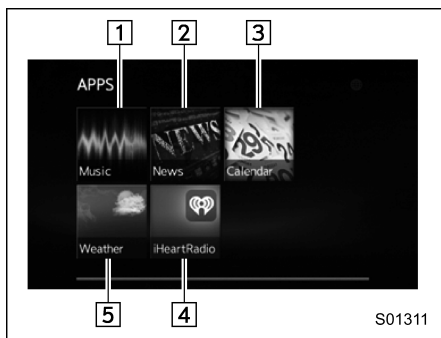

No.	Function
1	Select to go to the Music APPS screen.
2	Select to go to the News APPS screen.
3	Select to go to the Calendar APPS screen.
4	Select to go to the Weather APPS screen.
5	Select to go to the iHeartRadio APPS screen.

NOTE

The APPS icons shown here are sample images. The actual appearance of APPS may differ.

Error screen that is displayed while using STARLINK

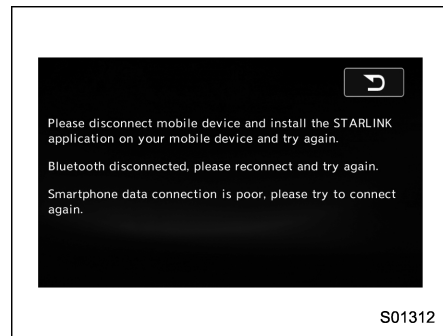

The error screen will be displayed while using STARLINK due to one of the following possible reasons.

- When your smartphone has no service or the Bluetooth communication is not possible.
- When your smartphone is turned off.
- When the STARLINK APPS is quit.
- When connection to the STARLINK server is not possible.
- When a problem occurs other than a server error.

NOTE

When using the STARLINK function, a disclaimer screen will be displayed. Be sure to fully read the contents before

using the function.

NOTE

Connection method

iPhone: USB

Android: Bluetooth

Supported devices

**iPhone: iPhone 4/iPhone 4s/iPhone 5
(iOS Ver. 5.1 or later)**

Android: (OS Ver. 4.0 or later)

Radio operation

■ AM/FM radio

▼ Overview

Select **AM** (AM) or **FM** (FM) on the “Select Audio Source (Select Audio Source)” screen. Refer to “Selecting an audio source” [12](#).

Control screen

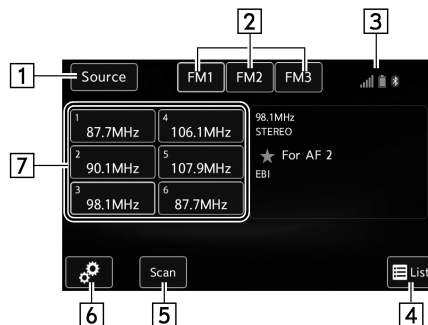

S01278

Control panel

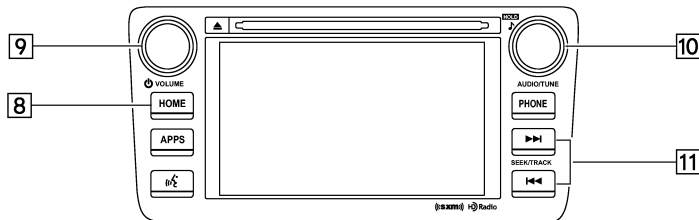

S02123

No.	Function
1	Select to display the audio source selection screen.
2	Select to change the FM band.
3	HD Radio indicator. The indicator on the top right of the screen changes according to the reception condition of HD Radio.
4	Select to display a station list.
5	Select to scan radio channels. This function enables searching for receivable stations automatically, and tunes in to a frequency for 5 seconds if a station is found. When the 5-second period has elapsed, the system searches for the next receivable station again, and tunes in to the frequency for 5 seconds.
6	Option key. Select to open the Option screen.
7	If you press a key for less than 1.5 seconds, the system tunes to the stored frequency. If you press a key for more than 1.5 seconds, the system stores the frequency to the selected preset channel. Refer to "Presetting a station" 34.
8	Select to display the sound setting screen. Refer to "Basic operation" 11.
9	Turn to adjust volume. Press to turn the audio system on/off.

No.	Function
10	Turn to step up/down frequencies. Press to select an audio mode.
11	Select to seek for a station/channel. Select and hold for continuous seek.

NOTE

- The radio automatically changes to stereo reception when a stereo broadcast is received.
- The radio automatically blends to an HD Radio signal in AM or FM where available.

Digital Sound

- Digital, CD-quality sound. HD Radio Technology enables local radio stations to broadcast a clean digital signal. AM sounds like today's FM and FM sounds like a CD.

▽ HD caution list

The following caution messages appear.

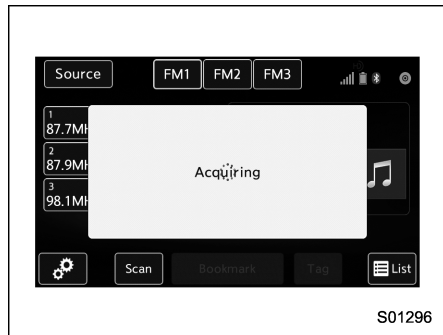

The message “Acquiring” appears in the following situations.

Caution Contents	Case	Conditions when caution disappears
This caution message appears when the system tries the digital reception.	When acquiring digital data while receiving a digital broadcast and SPS station.	<ul style="list-style-type: none"> • When the reception in digital of the SPS station is confirmed. • When the system determined that the SPS station could not be received. • When the SPS broadcast is ended (stopped) by the radio station while receiving SPS.

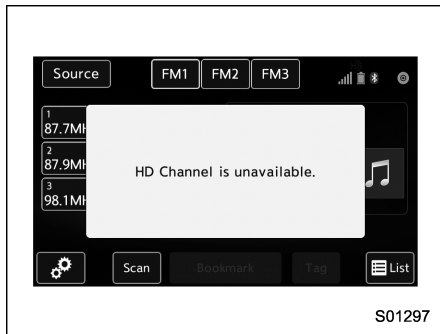

The message "HD Channel is unavailable" appears in the following situations.

Caution Contents	Case	Conditions when caution disappears
<p>This caution message appears when the digital reception is not possible.</p>	<ul style="list-style-type: none"> • When the system determined that the SPS station could not be received while receiving a digital broadcast and SPS station. • When the SPS broadcast is ended (stopped) by the radio station while receiving SPS. 	<ul style="list-style-type: none"> • When the status is changed to acquiring digital data because the reception condition of SPS station has improved. • When the received station is changed.

▼ Presetting a station

The AM band can store up to 12 stations (AM1 and AM2, 6 stations each).

The FM band can store up to 18 stations (FM1, FM2 and FM3, 6 stations each).

- AM2 and FM3 can store up to 6 stations when performing the auto store function.

The SAT band can store up to 30 stations. Refer to “Presetting a channel” 45.

1. Tune in the desired station.
2. If you press a key for more than 1.5 seconds, the system stores the frequency to the selected preset channel.

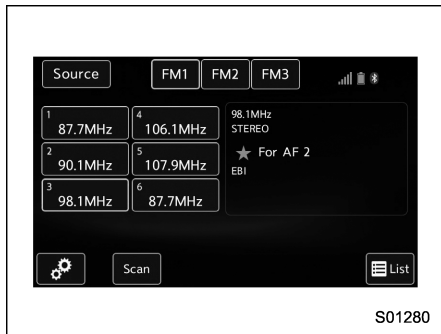

- To change the preset station to a different one, select and hold the preset station.

▼ Selecting a station from the list

A station list can be displayed.

1. Select **List**.

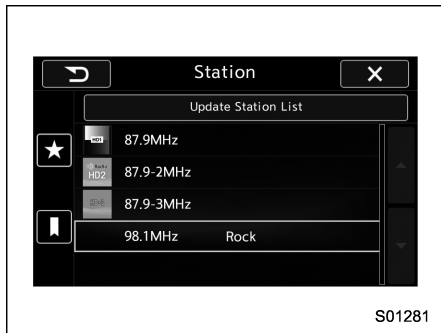

2. Select the desired station and then select **Back** (Back) or **Close** (Close).

▼ Update the station list

1. Select **Update Station List** (Update Station List) on the station list screen and the following screen will be displayed.



- **Cancel** (Cancel): Select to cancel the manual update.
- **OK** (OK): Select to execute the manual update.

NOTE

- The audio system sound is muted during refresh operation.
- In some situations, it may take some time to update the station list.

▼ Bookmark the list

1. Select **Bookmark** (Bookmark) on the station list screen and the following screen will be displayed.

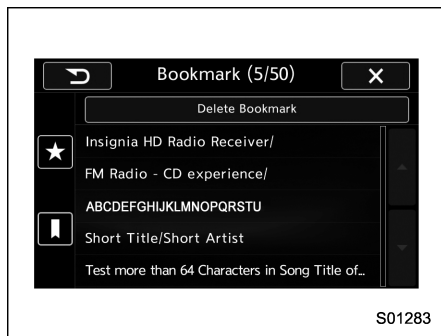

2. If you select an item from the bookmark list, the following image will be displayed.

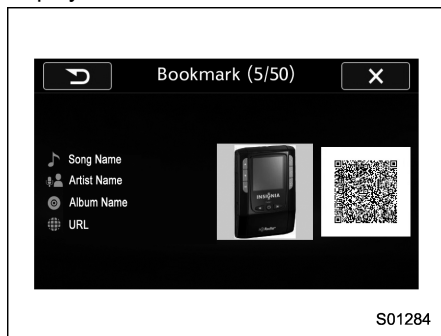

3. When you call up bookmark information, a QR code converted from the bookmark information will be displayed

on the screen. You can access a URL by reading the QR code using a smartphone, etc.

▼ Delete bookmark from the list

1. Select **Delete Bookmark** (Delete Bookmark) on the station list screen and the following screen will be displayed.

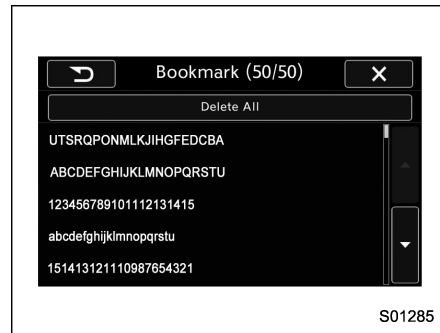

2. If you select an item from the bookmark list, the item will be deleted from the bookmark list.

3. If you select **Delete All** (Delete All), all bookmark items in the bookmark list will be deleted.

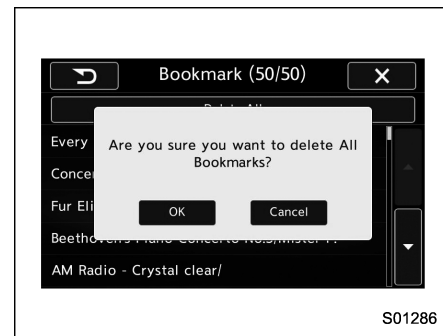

HD2/HD3

- FM stations can provide additional digital-only audio programming on HD2/HD3 Channels.

▼ Radio broadcast data system

This audio system is equipped with Radio Broadcast Data Systems (RBDS). RBDS mode allows text messages to be received from radio stations that utilize RBDS transmitters.

When RBDS is on, the radio can

- only select stations of a particular program type,
- display messages from radio stations,
- search for a stronger signal station.

▽ Selecting a desired program type list

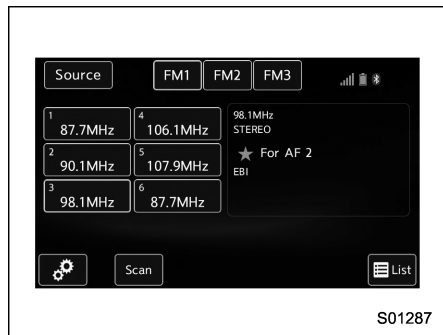

1. Select **Option** (Option).

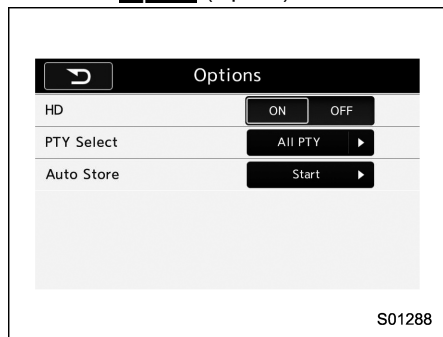

2. FM radio only: Select a desired program type list of station and select a desired station.

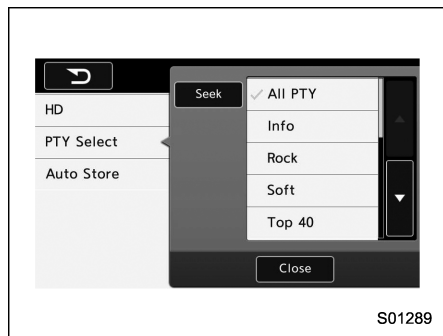

3. The program type list is in the following order:

- All PTY (All program type)
- Info
- Rock
- Soft
- Top 40
- Country
- Oldies
- Jazz
- Classical
- R & B (Rhythm and Blues)
- Religious
- Misc
- Weather

▽ Selecting a desired auto store

1. Select **Start** (Start) on the option screen and the following screen will be displayed.

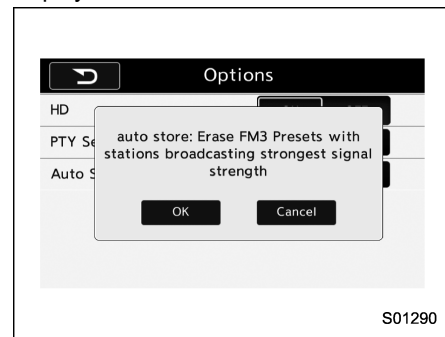

2. If you press a key for less than **OK** (OK), this function enables searching for receivable stations automatically, and pre-set of 6 stations whose signal strength is best, sorted by frequencies.

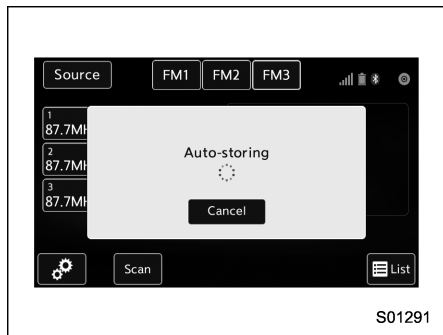

S01291

▼ About HD Radio™ technology

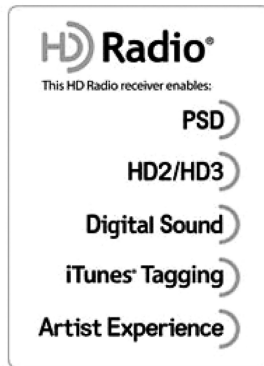

HD Radio Technology manufactured under license from iBiquity Digital Corporation. Foreign Patents. HD Radio™ and the HD, HD Radio, and “Arc” logos are proprietary trademarks of iBiquity Digital Corp.

HD Radio™ Technology is the digital evolution of analog AM/FM radio. Your radio product has a special receiver which allows it to receive digital broadcasts (where available) in addition to the analog broadcasts it already receives. Digital broadcasts have better sound quality than analog broadcasts as digital broadcasts provide free, crystal clear audio with no static or distortion. For more information,

and a guide to available radio stations and programming, refer to www.hdradio.com.

▼ Available HD Radio™ technology

▽ Multicast

On the FM radio frequency most digital stations have “multiple” or supplemental programs on one FM station.

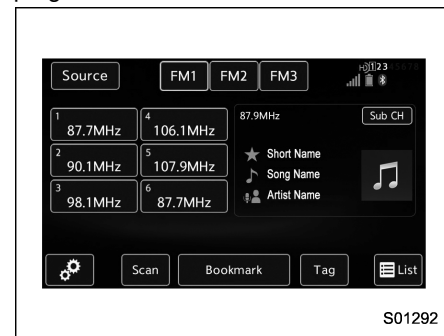

S01292

1. Select **Sub CH** (Sub CH) on the control screen and the following screen will be displayed.

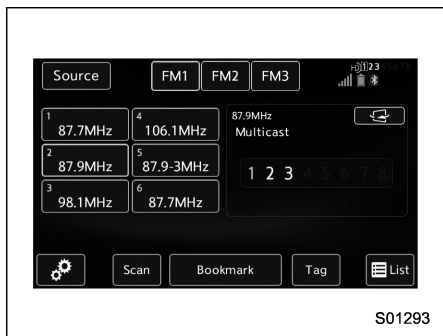

2. The indication that shows whether the current broadcast is digital or analog is displayed on the top right of the control screen.

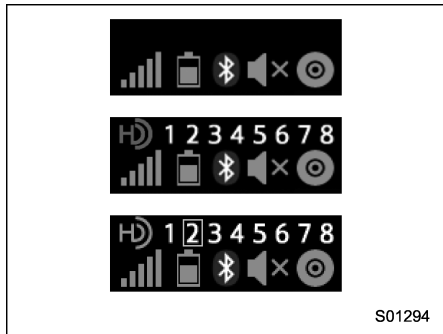

3. Select the desired channel.

- Turning the “AUDIO/TUNE” knob

can also select the desired multicast channel.

▽ Preserving a music information

Tag information in the music broadcasting is preserved in the system and transmits to an iPod.

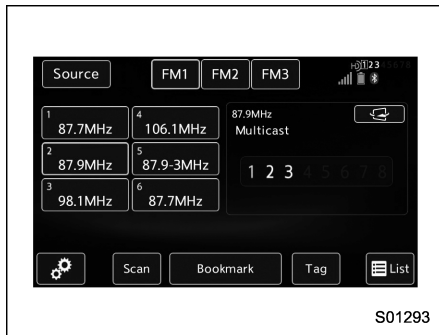

1. If you select a tag in the control screen while receiving HD Radio, the tag setting screen will be displayed.

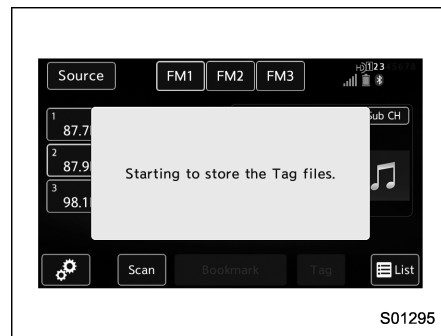

2. Connect an iPod. Refer to “Connecting and disconnecting a USB memory/portable device” 5.

- Turn on the power of the iPod if it is not turned on.
- Once an iPod is connected, the music tag moves from the radio into the iPod.
- When the iPod is connected to iTunes, the “tagged” information of the songs which were tagged while listening to the radio can be viewed. Then a user may decide to purchase the song or CD/Album which had been listened to on their radio.

In addition, the following caution messages appear.

Caution Contents	Display Message
If there is not enough memory in the digital audio	"Tag storage full"
If the same information is stored in the digital audio	"Already Stored"
If the store process in the digital audio failed	"Storing Failed"
If there is not enough memory in the iPod	"iPod full Tags cannot be stored"
If the system starts to transmit music information to an iPod	"Starting to transfer the Tag files."
If the transmitting process of music information to an iPod failed	"Transferring Failed"
If the transmitting process of music information to an iPod is successful	"X Tag(s) Sent" (X = number of transmitted information) will be displayed.

NOTE

- The tag information can not be preserved while scanning or caching the radio station.
- If tagging the music information fails, "Saving the HD Radio tag was unsuccessful. (Saving the HD Radio tag was unsuccessful.)" will be displayed on the screen. If this occurs, tag the information again.
- HD Radio™ stations can be preset.
- An orange **HD** (HD)) will be displayed on the screen when in digital. The **HD** (HD)) will first appear in a gray color indicating the station is indeed (an analog and) a digital station. Once the digital signal is acquired, the logo will change to a bright orange color.
- The song title and artist name will appear on the screen when available by the radio station. The radio station can send album pictures when available.
- As a user works through the analog radio stations, (where applicable) the radio receiver will automatically tune from an analog signal to a digital signal within 5 seconds.

PSD)

- Program Service Data: Presents song name, artist, station IDs, and other relevant data streams.

iTunes® Tagging)

- iTunes Tagging provides you the opportunity to discover a wide range of content and the means to “tag” that content for later review and purchase from the iTunes Store. Also refer to the Apple Automotive specifications for implementing iTunes Tagging.

Artist Experience)

- Visual information related to content being played on your HD Radio receiver, such as Album Art, historical photographs, still art from live broadcasts, among other related content.

▼ Troubleshooting guide

Experience	Cause	Action
Mismatch of time alignment - a user may hear a short period of programming replayed or an echo, stutter or skip.	The radio stations analog and digital volume is not properly aligned or the station is in ballgame mode.	None, radio broadcast issue. A user can contact the radio station.
Sound fades, blending in and out.	Radio is shifting between analog and digital audio.	Reception issue, may clear-up as the vehicle continues to be driven. Turning the indicator of the "HD Radio™" button off can force radio in an analog audio.
Audio mute condition when an HD2/HD3 multicast channel had been playing.	The radio does not have access to digital signals at the moment.	This is normal behavior, wait until the digital signal returns. If out of the coverage area, seek a new station.
Audio mute delay when selecting an HD2/ HD3 multicast channel preset.	The digital multicast content is not available until HD Radio™ broadcast can be decoded and make the audio available. This takes up to 7 seconds.	This is normal behavior, wait for the audio to become available.
Text information does not match the present song audio.	Data service issue by the radio broadcaster.	Broadcaster should be notified. Complete the form; www.ibequity.com/automotive/report_radio_station_experiences .
No text information shown for the present selected frequency.	Data service issue by the radio broadcaster.	Broadcaster should be notified. Complete the form; www.ibequity.com/automotive/report_radio_station_experiences .

■ SiriusXM Satellite Radio (if equipped)

▼ Overview

Select **SiriusXM** (SiriusXM) on the “Select Audio Source (Select Audio Source)” screen. Refer to “Selecting an audio source” 12.

Control screen

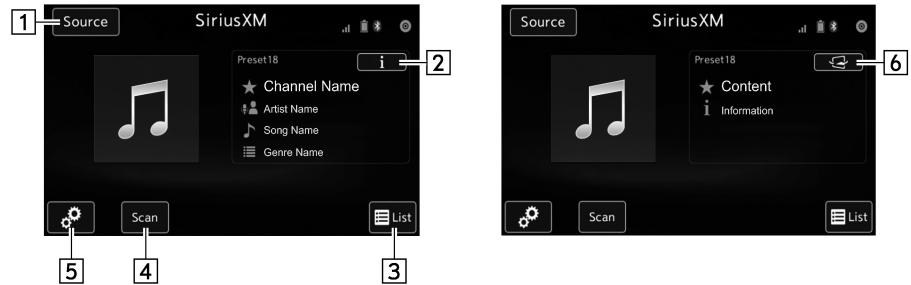

S01303

Control panel

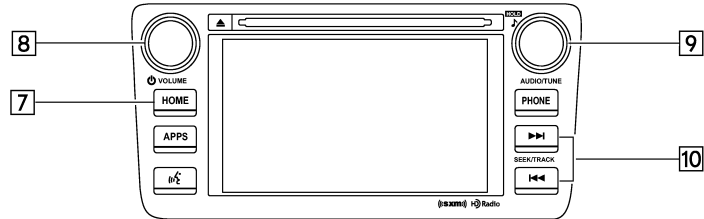

S02124

No.	Function
1	Select to display the audio source selection screen.
2	Display the contents information of a channel receiving.
3	Select to display each list.
4	Search for a channel from the direction of a higher frequency than the current frequency and play each channel that can be received for five seconds.
5	Option key. Select to open the Option screen.
6	Return to the control screen.
7	Select to display the sound setting screen. Refer to "Basic operation" 11.
8	Turn to adjust volume. Press to turn the audio system on/off.
9	Turn right to step up channels and turn left to step down channels.
10	Select to step up/down channels. Select and hold to step up/down channels fast.

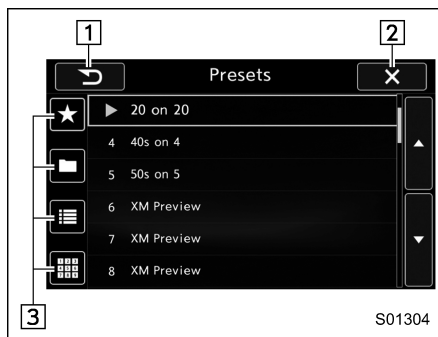

No.	Function
1	Return to the previous screen.
2	Return to the control screen.
3	Press each tab key to switch the list screen. Presets tab: Presets list is displayed. Categories tab: Categories list is displayed. All Channels tab: All channels list is displayed. Direct Tune tab: Change to the Direct Tune display.

▼ How to subscribe to SiriusXM Satellite Radio

To listen to a satellite radio broadcast in the vehicle, a subscription to the SiriusXM Satellite Radio service is necessary.

A SiriusXM Satellite Radio is a tuner designed exclusively to receive broadcasts provided under a separate subscription.

▽ How to subscribe

It is necessary to enter into a separate service agreement with SiriusXM Satellite Radio in order to receive satellite broadcast programming in the vehicle. Additional activation and service subscription fees apply that are not included in the purchase price of the vehicle and digital satellite tuner.

- For complete information on subscription rates and terms, or to subscribe to SiriusXM Satellite Radio:

- U.S. customers:
Refer to www.siriusxm.com or call 1-866-635-2349

**WARNING**

- **SiriusXM Satellite Radio Services — Legal Disclaimers and Warnings**
 - Fees and Taxes — Subscription fee, taxes, one time activation fee, and other fees may apply. Subscription fee is consumer only. All fees and programming subject to change. Subscriptions subject to Customer Agreement available at www.siriusxm.com (U.S.). SiriusXM U.S. satellite and data services are available only in the contiguous USA and DC.
 - Explicit Language Notice — Channels with frequent explicit language are indicated with an “XL” preceding the channel name. Channel blocking is available for SiriusXM Satellite Radio receivers by notifying SiriusXM at:
- **U.S. customers:**
Visit www.siriusxm.com or call 1-866-635-2349

**CAUTION**

- It is prohibited to copy, decompile, disassemble, reverse engineer, hack, manipulate, or otherwise make available any technology or software incorporated in receivers compatible with the SiriusXM Satellite Radio System or that support the XM website, the Online Service or any of its content. Furthermore, the AMBE[®] voice compression software included in this product is protected by intellectual property rights including patent rights, copyrights, and trade secrets of Digital Voice Systems, Inc.
- **Note:** this applies to SiriusXM Satellite Radio receivers only and not XM Ready devices.

NOTE

- **SiriusXM Satellite Services — Descriptions**
 - Only SiriusXM Satellite Radio[®] brings you more of what you love, all in one place. Get over 175 channels, including commercial-free music, plus the best sports, news, talk, comedy and entertain-

ment. Welcome to the world of satellite radio. More information about SiriusXM Satellite Radio is available online at www.siriusxm.com (U.S.).

- **SiriusXM Satellite Services — Subscription Instructions**
 - For SiriusXM Services requiring a subscription (such as SiriusXM Satellite Radio, and some Infotainment & data services), the following paragraph shall be included. Required SiriusXM Satellite Radio and some Infotainment & data services monthly subscriptions sold separately after trial period. Subscription fee is consumer only. All fees and programming subject to change. Subscriptions are subject to the Customer Agreement available at www.siriusxm.com (U.S.). Sirius, XM and all related marks and logos are trademarks of Sirius XM Radio Inc. All other marks, channel names and logos are the property of their respective owners.

For more information, program schedules, and to subscribe or extend subscription after complimentary trial period; more information is available at:

- U.S. customers:

Visit www.siriusxm.com or call 1-866-635-2349

- SiriusXM Satellite Radio is solely responsible for the quality, availability and content of the satellite radio services provided, which are subject to the terms and conditions of the SiriusXM Satellite Radio customer service agreement.

- Customers should have their radio ID ready; the radio ID can be found by tuning to “Ch 000” on the radio. For details, see “DISPLAYING THE RADIO ID” below.

- All fees and programming are the responsibility of SiriusXM Satellite Radio and are subject to change.

▼ Displaying the Radio ID

Each SiriusXM tuner is identified with a unique radio ID. The radio ID is required when activating an SiriusXM Satellite Services or when reporting a problem.



S01307

1. If “Ch 000” is selected using the “AUDIO/TUNE” knob, the ID code, will be displayed.

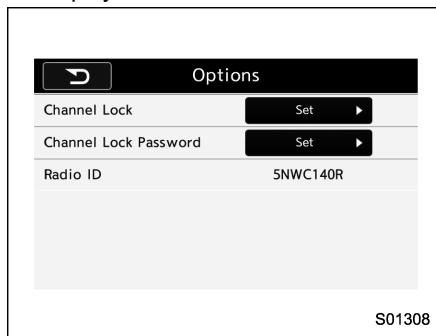

S01308

2. If you touch the Option key, the Radio ID will be displayed on the Option screen.

▼ Presetting a channel

1. The Presets list is displayed via either of the following procedures.

- When you press the List key in the SiriusXM main screen (if the list that was displayed the last time is Presets).
- When you select the Categories tab (star icon) in each list screen.

2. The current channel is stored if you press and hold the Preset list key for 1.5 seconds. You can store up to 30 channels (A beep sounds when a channel stored).

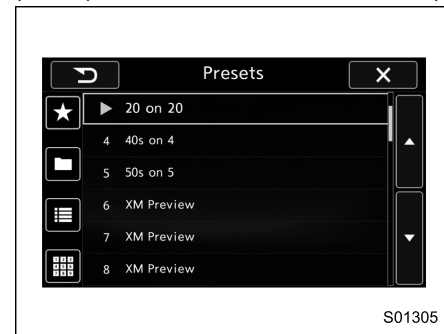

S01305

- The “Playing” icon is displayed for the currently selected channel.

▼ Selecting a channel from the list

- The Categories list is displayed via either of the following procedures.
 - When you press the List key in the SiriusXM main screen (if the list that was displayed the last time is Categories).
 - When you select the Categories tab (folder icon) in each list screen.
- Each channel list is displayed when you select each category item.

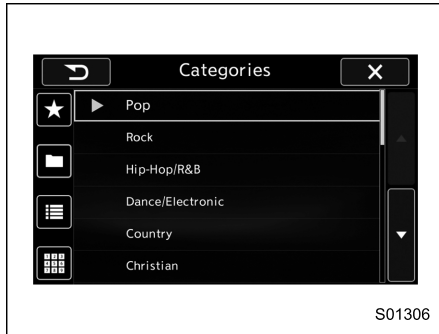

In addition, the following caution messages appear.

Caution Contents	Display Message
An update to your SiriusXM subscription has been received by the SiriusXM tuner. Press any button to continue.	Subscription Update Press OK to Continue
This channel is not a valid SiriusXM channel. The channel number has been entered incorrectly, or the channel was removed from the SiriusXM channel lineup.	Channel XXX Not Available ("XXX" refers to the selected channel number.)
This channel is not included in your SiriusXM subscription plan.	Channel XXX not subscribed. Call SiriusXM to subscribe. ("XXX" refers to the selected channel number.)
The selected channel has been locked by the parental controls. A prompt to enter the unlock code will appear.	Ch Locked Lock Code?
Ensure the SiriusXM antenna cable is connected to the SiriusXM tuner correctly. Check the SiriusXM antenna wire for breaks or sharp bends. Replace the antenna if necessary.	Check Antenna
The vehicle must be outside, and the antenna must have a clear view of the southern sky.	No Signal

NOTE

Contact SiriusXM Listener Care Center (U.S. customers): 1-866-635-2349

Media operation

■ CD

▼ Overview

The CD operation screen can be reached by the following methods:

- Insert a disc. Refer to “Loading and unloading a disc” 4.
- Select **DISC** (DISC) on the “Select Audio Source (Select Audio Source)” screen. Refer to “Selecting an audio source” 12.

Control screen

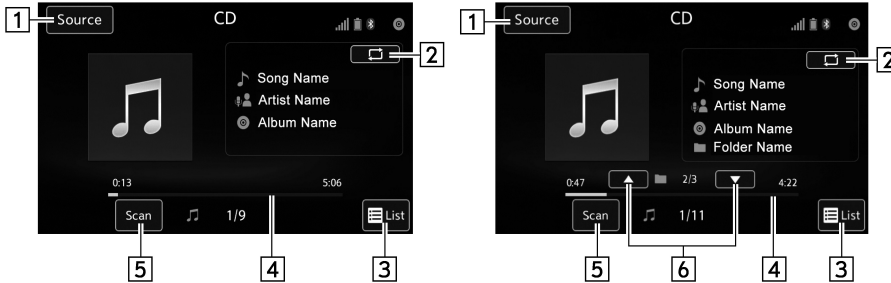

S01196

Left: Audio CD, Right: MP3/WMA/AAC disc

Control panel

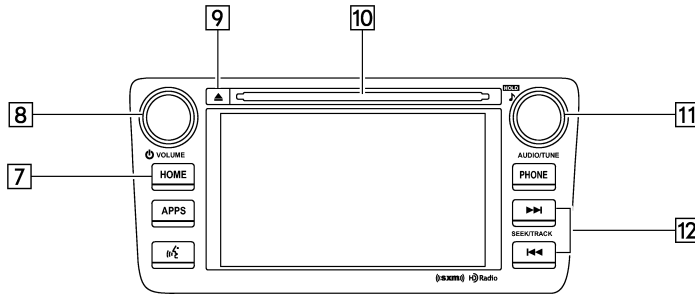

S02125

No.	Function
1	Select to display the audio source selection screen.
2	Select to display Trick Play Settings screen.
3	Audio CD Select to display a track list. MP3/WMA/AAC disc Select to display a folder list
4	Shows progress.
5	The tracks in the disc are played back for ten seconds each from the beginning of the track.
6	MP3/WMA/AAC disc Select to choose a folder.
7	Select to display the sound setting screen. Refer to "Basic operation" 11.
8	Turn to adjust volume. Press to turn the audio system on/off.
9	Press to eject a disc.
10	Disc slot
11	Turn to select a track/file. Press to select an audio mode.
12	Select to select a track/file. Select and hold to fast forward/rewind.

Control screen (Trick Play)

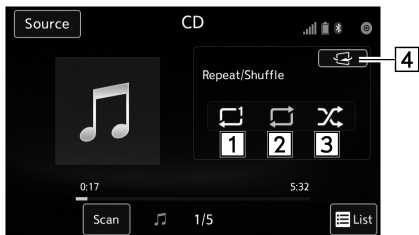

S01198

Left: Audio CD, Right: MP3/WMA/AAC disc

No.	Function
1	Select to start 1 Track Repeat.
2	Select to start Repeat All.
3	Select to start Shuffle All.
4	Return to the control screen.
5	Select to start Folder Repeat.
6	Select to start Shuffle Folder.

NOTE

- If a disc contains CD-DA files and MP3/WMA/AAC files, only the CD-DA files can be played back.
- If a CD-TEXT disc is inserted, the title of the disc and track will be displayed. Up to 32 characters can be displayed.
- If the disc contains no CD-TEXT, only the track number would be displayed on the screen.

■ USB memory

Audio files on the USB memory can be played back.

▼ Overview

The USB Audio playback screen can be reached by the following methods:

- Connect a USB memory. Refer to “Connecting and disconnecting a USB memory/portable device” 5.
- Select **USB/iPod** (USB/iPod) on the “Select Audio Source (Select Audio Source)” screen. Refer to “Selecting an audio source” 12.

Control screen



Control panel

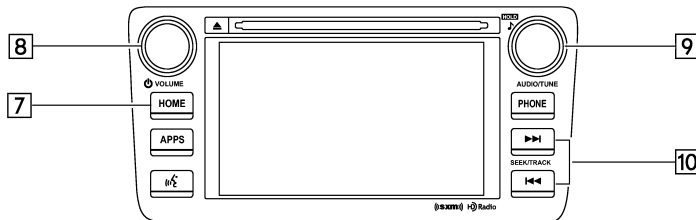

S01199

S02124

No.	Function
1	Select to display the audio source selection screen.
2	Select to display Trick Play Settings screen.
3	Select to display Folders List.
4	Shows progress.
5	The tracks in the disc are played back ten seconds each from the beginning of the track.
6	Select to choose a folder.
7	Select to display the sound setting screen. Refer to "Basic operation" ¶ 11.
8	Turn to adjust volume. Press to turn the audio system on/off.
9	Turn to select a file/track. Press to select an audio mode.
10	Select to select a file/track. Select and hold to fast forward/rewind.

Control screen (Trick Play)



S01201

No.	Function
1	Select to start 1 Track Repeat.
2	Select to start Folder Repeat.
3	Select to start Repeat All.
4	Return to the control screen.
5	Select to start Shuffle All.
6	Select to start Shuffle Folder.

**WARNING**

Do not operate the player's controls or connect the USB memory while driving.

**CAUTION**

- Do not leave your portable player in the car. In particular, high temperatures inside the vehicle may damage the portable player.
- Do not push down on or apply unnecessary pressure to the portable player while it is connected as this may damage the portable player or its terminal.
- Do not insert foreign objects into the port as this may damage the portable player or its terminal.

■ iPod**▼ Overview**

The iPod operation screen can be reached by the following methods:

- Connect an iPod. Refer to “Connecting and disconnecting a USB memory/portable device” 5.
- Select **USB/iPod** (USB/iPod) on the “Select Audio Source (Select Audio Source)” screen. Refer to “Selecting an audio source” 12.

Control screen

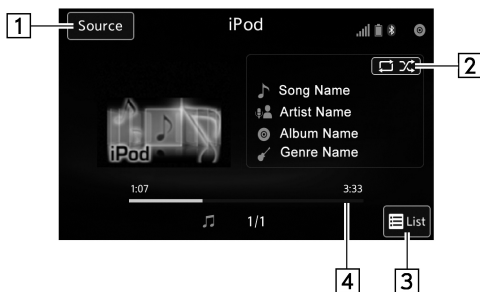

Control panel

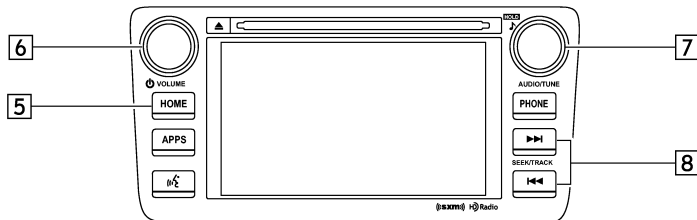

S01202

S02126

No.	Function
1	Select to display the audio source selection screen.
2	Select to display Trick Play Settings screen.
3	Select to display iPod List.
4	Shows progress.
5	Select to display the sound setting screen. Refer to "Basic operation"  11.
6	Turn to adjust volume. Press to turn the audio system on/off.
7	Turn to select a track/file. Press to select an audio mode.
8	Select to select a track/file. Select and hold to fast forward/rewind.

Control screen (Trick Play)

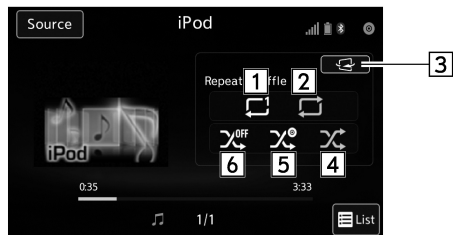

S01204

No.	Function
1	Select to start 1 Track Repeat.
2	Select to start Repeat All.
3	Return to the control screen.
4	Select to start Shuffle Track.
5	Select to start Shuffle Album.
6	Select to turn off Shuffle.

Control screen (Play List)

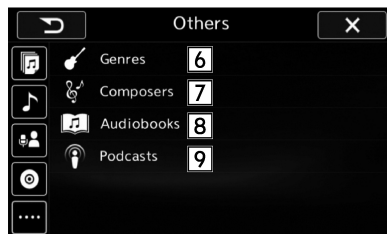
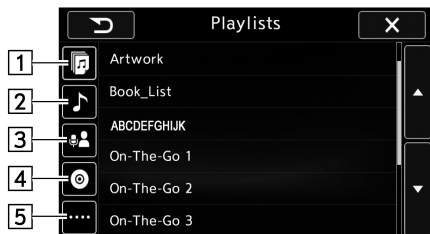

S01205

No.	Function
1	Select to display the Playlist.
2	Select to display Song List.
3	Select to display Artists List.
4	Select to display Albums List.
5	Select to open Others List.
6	Select to open Genres List.
7	Select to open Composers List.
8	Select to open Audiobooks List.
9	Select to open Podcasts List.

**WARNING**

Do not operate the player's controls or connect the iPod while driving.

**CAUTION**

- Do not leave your portable player in the car. In particular, high temperatures inside the vehicle may damage the portable player.
- Do not push down on or apply unnecessary pressure to the portable player while it is connected as this may damage the portable player or its terminal.
- Do not insert foreign objects into the port as this may damage the portable player or its terminal.

NOTE

- When an iPod is connected using a genuine iPod cable, the iPod starts charging its battery.
- When an iPod is connected and the audio source is changed to iPod mode, the iPod will resume playing from the same point it was last used.
- Depending on the iPod that is connected to the system, certain functions

may not be available.

- Files/tracks selected by operating a connected iPod may not be recognized or displayed properly.

Bluetooth audio

The Bluetooth audio system enables users to enjoy listening to music that is played on a portable player on the vehicle speakers via wireless communication.

This audio system supports Bluetooth, a wireless data system capable of playing portable audio music without cables. If your device does not support Bluetooth, the Bluetooth audio system will not function.

▼ Overview

Select **BT Audio** (BT Audio) on the "Select Audio Source (Select Audio Source)" screen. Refer to "Selecting an audio source" 12.

Depending on the type of portable player connected, some functions may not be available and/or the screen may look differently than shown in this manual.

Control screen

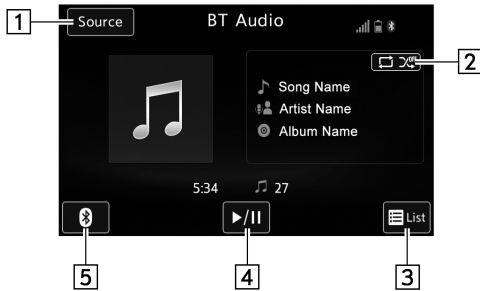

S01206

Control panel

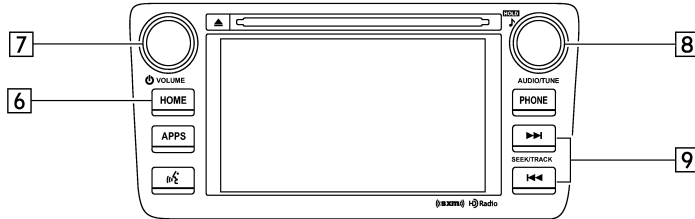

S02127

No.	Function
1	Select to display the audio source selection screen.
2	Select to display Trick Play Settings screen.
3	Select to display as a list (for the models with AVRCP Ver. 1.4 or higher).
4	Select to play back or pause a track. The track pauses when pressed during playback and plays back when pressed during pause.
5	Select to open Bluetooth Settings.
6	Select to display the sound setting screen. Refer to "Basic operation" 11.
7	Turn to adjust volume. Press to turn the audio system on/off.
8	Turn to select a track. Press to select an audio mode
9	Select to select a track. Select and hold to fast forward/rewind.

Control screen (Play List)

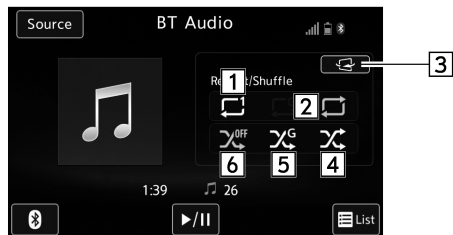

S01208

No.	Function
1	Select to start 1 Track Repeat.
2	Select to start Repeat All.
3	Return to the control screen.
4	Select to start Shuffle Track.
5	Select to start Group Shuffle.
6	Select to turn off Shuffle.



**WARNING**

- Do not operate the player's controls or connect to the Bluetooth audio system while driving.
- Your audio unit is fitted with Bluetooth antennas. People with implantable cardiac pacemakers, cardiac resynchronization therapy-pacemakers or implantable cardioverter defibrillators should maintain a reasonable distance between themselves and the Bluetooth antennas. The radio waves may affect the operation of such devices.
- Before using Bluetooth devices, users of any electrical medical device other than implantable cardiac pacemakers, cardiac resynchronization therapy-pacemakers or implantable cardioverter defibrillators should consult the manufacturer of the device for information about its operation under the influence of radio waves. Radio waves could have unexpected effects on the operation of such medical devices.

**CAUTION**

Do not leave your portable player in the vehicle. In particular, high temperatures inside the vehicle may damage the portable player.

NOTE

- Depending on the Bluetooth device that is connected to the system, the music may start playing when selecting  while it is paused. Conversely, the music may pause when selecting  while it is playing.
- In the following conditions, the system may not function:
 - The Bluetooth device is turned off.
 - The Bluetooth device is not connected.
 - The Bluetooth device has a low battery.
- It may take time to connect the phone when Bluetooth audio is being played.
- For operating the portable player, see the instruction manual that comes with it.
- If the Bluetooth device is disconnected due to poor reception from the Bluetooth network when the ignition

switch is in the “ACC” or “ON” position, the system will automatically reconnect to the portable player.

- If the Bluetooth device is disconnected on purpose, such as it was turned off, this does not happen. Reconnect the portable player manually.

- Bluetooth device information is registered when the Bluetooth device is connected to the Bluetooth audio system. When selling or disposing of the vehicle, remove the Bluetooth audio information from the system. Refer to “Other settings”  9.

▼ Connecting a Bluetooth device

To use the Bluetooth audio system, it is necessary to register a Bluetooth device with the system.

Registering an additional device

1. Select the Bluetooth Setting Key on the BT Audio menu screen.
2. Select **Add** (Add) on the BT Devices Connection screen.
3. Register a Bluetooth device.
4. For more information: Refer to “Registering a Bluetooth device”  81.

Selecting a registered device

1. Select the Bluetooth Setting Key on the BT Audio menu screen.

2. Select **Select** (Select) on the BT Devices Connection screen.
3. For more information: Refer to “Connecting a Bluetooth device” 82.

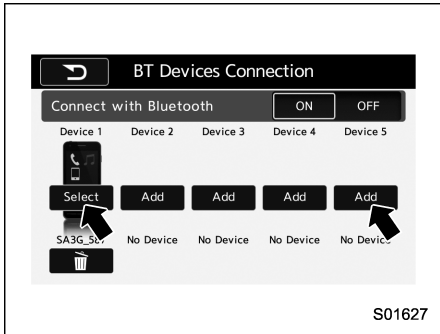
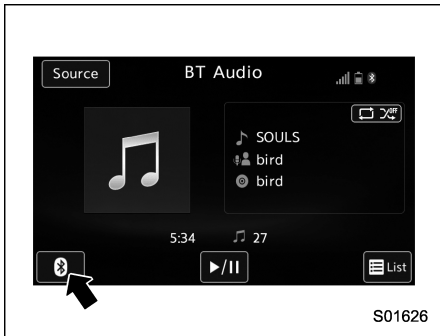

■ aha™ by HARMAN

aha is a cloud-based application that connects to the system and gives you access to your favorite web content safely and easily. There are over 30,000 stations spanning internet radio, personalized music, audiobooks, Facebook, Twitter, restaurant and hotel searches, weather and more. For more information about aha, go to the aha site (<http://www.aharadio.com>).

aha™ and the aha logo are the trademarks of HARMAN International Industries, Incorporated



When connecting iPhone and iPod touch or Android devices with the aha application installed, you can control, view, and hear aha content through the system.

In order to connect to this system, use a USB port for an iPhone or iPod touch and Bluetooth for Android devices.

In this chapter, iPhone and iPod touch or Android devices will be referred to as a smartphone.

▼ Overview

Control screen



S01209

Control panel

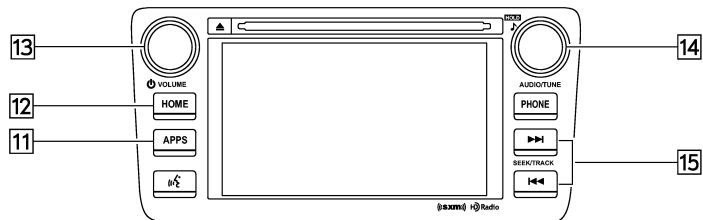

S02128

No.	Function
1	Select to display the audio source selection screen.
2	Select to open Station List.
3	Select to fast forward the current content item by 30 seconds.
4	Select to display the Contents List of the selected station.
5	Select to make a phone call to the current content item. A phone number is distributed depending on content items. This feature is available only in these cases.
6	Select to play back or pause a track. The track pauses when pressed during playback and plays back when pressed during pause.
7	Select to set "Like".
8	Select to set "Dislike".
9	Select to start the playback from the beginning of the content in the target station.
10	Select to rewind the current content item by 15 seconds.
11	To display the APPS menu screen, select the "STARLINK". Or, to display the aha screen, select "aha" or to display the Pandora screen, select "Pandora".

No.	Function
12	Select to display the sound setting screen. Refer to "Basic operation"  11.
13	Turn to adjust volume. Press to turn the audio system on/off.
14	Turn to display the next/previous content item. Press to select an audio mode
15	Select to display the next/previous content item.

Control screen (Station Display)

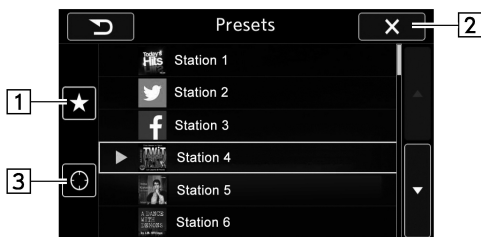

No.	Function
1	Select to display Preset List.
2	Return to the control screen.
3	Select to display Nearby List.

S01211

**WARNING**

- Do not connect or operate the smartphone while driving.
- Be sure to park the vehicle in a safe location before connecting or operating the smartphone.

**CAUTION**

- Do not leave your smartphone in the car. In particular, high temperatures inside the vehicle may damage the smartphone.
- Do not push down on or apply unnecessary pressure to the smartphone while it is connected as this may damage the smartphone or its terminal.
- Do not insert foreign objects into the port as this may damage the smartphone or its terminal.

NOTE

- For safety reasons, certain functions are not available while your vehicle is in motion.
- In order to maximize signal reception, performance and precision of the smartphone, please ensure the smart-

phone is placed as close to the system as possible, while ensuring it is stowed and secure while driving.

- Use USB cables of iPhone/iPod touch accessories.
- When the ignition switch is in the “ACC” or “ON” position, the battery of the connected iPhone/iPod touch is charged.
- iPhone/iPod touch may not be recognized when the ignition switch is in the “ACC” or “ON” position. In this case, remove the iPhone/iPod touch and reconnect it.
- The accuracy of the displayed information or the signal reception performance depends on the smartphone or the connected device, and it’s wireless connection.
- Since the aha application uses signals from GPS satellites and wireless communication lines, it may not work properly in the following locations.
 - In a tunnel
 - In underground parking lots
 - Outside wireless communication range, such as some countryside areas
 - Where the wireless communication network is congested, or where communications are restricted
- Depending on the circumstances

and environment, the signal may be weak or not be received. In such cases, an error may occur.

- Top 35 entries in the preset station list on the smartphone are displayed. When there are more than 35 entries in the preset station list, change the order of the entries in the list on the smartphone. You can change the priority of your preset stations within the aha application (after disconnected from this system) to modify the station list shown on the screen. Please see your smartphone aha application “Edit Presets (in Main menu)” to modify this list.
- For operating the smartphone, see the instruction manual that comes with it.
- If there are multiple music files stored on your iPhone or iPod touch, it may take some time until playback starts.
- Playback may be intermittent when you switch to streaming Bluetooth audio from aha on your smartphone device.
- When connecting the device via Bluetooth, the communication speed may become slower than via USB.

▼ Before using aha application

In order to use the aha application on this system, the application must be installed on the smartphone.

▽ Settings required to use aha application

- Search and download the aha application from your smartphone app store.
 - iPhone and iPod touch: Apple App Store via iTunes
 - Android device: Google Play Store
- Create an account and login to the aha application on the smartphone.

NOTE

Please use the latest version of the aha application.

▽ About app-based connected content

Requirements for using the connected content services of the aha application on this system.

- Latest version of the system is compatible with connected content application(s) for the smartphone, available from aha, downloaded to your smartphone.
- A current account with a wireless content service provider.
- A smartphone data plan: If the data plan for your smartphone does not provide

for unlimited data usage, additional charges from your carrier may apply for accessing app-based connected content via 3G, 4G, Wi-Fi, or 4G LTE wireless networks.

- Connection to the internet via 3G, 4G, Wi-Fi, or 4G LTE networks.

NOTE

- **Changes to product specifications may result in differences between the content of the manual and features of the product.**
- **Be careful not to exceed the data usage limits for your smartphone. Doing so will result in additional data usage charges from your phone carrier.**
- **Access to app-based connected content will depend on the availability of wireless cellular and/or Wi-Fi network coverage for the purpose of allowing your smartphone to connect to the internet.**
- **Service availability may be geographically limited by region. Consult the wireless connected content service provider for additional information.**
- **Ability of this product to access connected content is subject to change without notice and could be affected by any of the following: compatibility**

issues with future firmware versions of the smartphone; compatibility issues with future versions of the connected content application(s) for the smartphone; changes to or discontinuation of the connected content application(s) or service by its provider.

- **Communication and phone call charges for smartphones should be paid by the wireless subscriber.**
- **If you lose the data in a smartphone or other device while using it with the system, no compensation will be given for the lost data.**
- **Fuji Heavy Industries makes no guarantee regarding the content provided by aha.**
- **aha may not work due to factors on smartphones, smartphone applications or stations. Fuji Heavy Industries is not responsible for it.**

▽ **About the supported devices**

This system supports the following devices.

For iPhone/iPod touch users

Type	Generation	Firmware version or OS
iPhone	iPhone 3G	iOS 4.2.x
	iPhone 3GS	iOS 6.1.x
	iPhone 4	iOS 7.0.x
	iPhone 4s	iOS 7.0.x
	iPhone 5	iOS 7.0.x
	iPhone 5c	iOS 7.0.x
	iPhone 5s	iOS 7.0.x
iPod touch	iPod touch	iOS 3.1.x
	iPod touch 2	iOS 4.2.x
	iPod touch 3	iOS 5.1.x
	iPod touch 4	iOS 6.1.x
	iPod touch 5	iOS 7.0.x

NOTE

Note that the warranty does not apply if an unsupported iPhone/iPod touch is connected.

For Android device users

Android OS	Specification	Profile
Android Ver. 2.2 or Ver. 2.3	Bluetooth Specification Ver. 1.1 or higher (Ver. 2.0 + EDR or higher is recommended)	<ul style="list-style-type: none">• aha Connect Binary API over SPP• Digital audio by A2DP

NOTE

The available functions may vary depending on the type of Android device.

▼ Using aha application

If you connect a smartphone to this system after starting a supported aha application on the smartphone, you can display and operate the aha application displayed on the smartphone on the system screen.

NOTE

- Connect a smartphone to the USB port before turning the ignition switch to the “ACC” or “ON” position.
- When it is not played back normally, press the POWER/VOLUME knob twice while a USB cable is connected.

1. Run the aha application on your smartphone.
2. Connect the iPhone/iPod touch to the USB port or connect the Android device by utilizing the Bluetooth connection (SPP and A2DP profile).
 - For details about connecting an iPhone/iPod touch: Refer to “Connecting and disconnecting a USB memory/portable device” 5.
 - For details about registering or connecting an Android device: Refer to “Registering/connecting Bluetooth® device” 78.
3. Select “aha” on the “Select Audio Source (Select Audio Source)” screen.

Refer to “Basic operation” 11.

Select “aha” on the “Apps (APPS)” screen. Refer to “STARLINK” 27.

4. Check that the top screen is displayed.

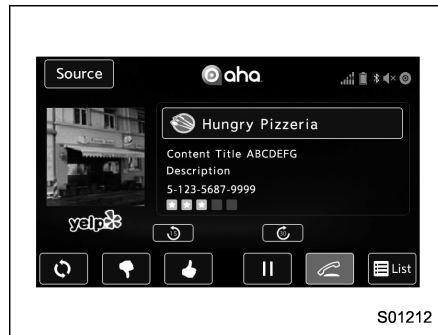

5. Select the desired station.
6. Check that the station operation screen is displayed.

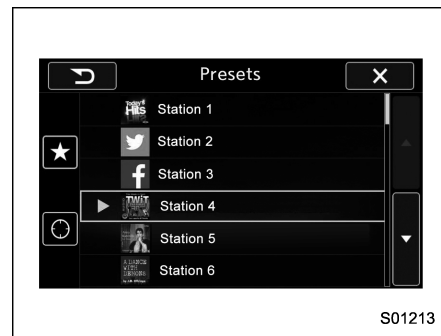

- Main functions of the station operation screen button: Refer to “Station operation screen buttons” 70.
- For details on the services or the operations, check the aha site (<http://www.aharadio.com>) on the internet.









NOTE

- When iPhone/iPod touch and Android devices are connected at the same time, iPhone/iPod touch is prioritized.
- The following operations are not available on this system. Perform these operations on the smartphone.
 - Add/Reorder/Delete stations
 - Login to Facebook/Twitter

● For the aha function, the following touch screen gestures are not available.

- Multi-touch operation
- Double-tap

▽ Station operation screen buttons

Button	Function
	Select to start playback.
	Select to pause playback.
	Select to stop playback.
	Select to upload "Like" information to the application server. To cancel "Like" information that is being uploaded to the server, select this button again.
	Select to upload "Dislike" information to the application server. To cancel "Dislike" information that is being uploaded to the server, select this button again.
	Select to make a phone call to the current content item.
	Select to start the playback from the beginning of the content in the target station.
	Select to rewind the current content item by 15 seconds.
	Select to fast forward the current content item by 30 seconds.

NOTE

The button display will vary depending on each station or content item.

■ AUX

▼ Overview

The AUX operation screen can be reached by the following methods:

- Connect a portable audio device. Refer to "Connecting and disconnecting a USB memory/portable device" 5.
- Select **AUX** (AUX) on the "Select Audio Source (Select Audio Source)" screen. Refer to "Selecting an audio source" 12.

Control screen

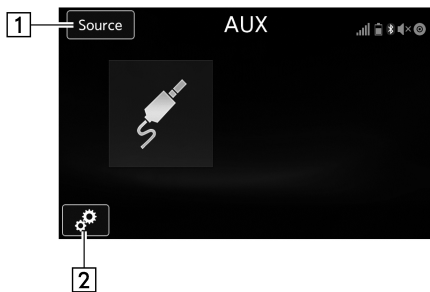

S01214

Control panel

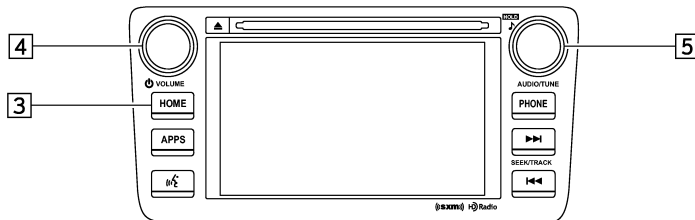

S02129

No.	Function
1	Select to display the audio source selection screen.
2	Select to open the Options screen.
3	Select to display the sound setting screen. Refer to "Basic operation" 11.
4	Turn to adjust volume. Press to turn the audio system on/off.
5	Press to select an audio mode.

Control screen (Option Display)

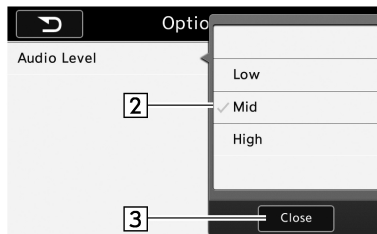

S01216

No.	Function
1	Select to adjust the audio gain level.
2	Select High, Mid, or Low for the audio gain level. The High setting has greater effect.
3	Select to close the list.

**WARNING**

Do not operate the player's controls or connect the portable audio device while driving.

**CAUTION**

- **Do not leave portable audio device in the vehicle. The temperature inside the vehicle may become high, resulting in damage to the player.**
- **Do not push down on or apply unnecessary pressure to the portable audio device while it is connected as this may damage the portable audio device or its terminal.**
- **Do not insert foreign objects into the port as this may damage the portable audio device or its terminal.**

■ Pandora® (if equipped)

Pandora is an application for a smartphone. This can automatically select and play recommended tracks.

By rating the track currently playing, tracks that better match your preference will be recommended.

In order to connect to this system, use a USB port for an iPhone or iPod touch and Bluetooth for Android devices.

Depending on differences between models or software version etc., some models might be incompatible with this system.

This function is not available if the Pandora application has not been installed on the smartphone.

NOTE

- **Connect a smartphone to the USB port before turning the ignition switch to the "ACC" or "ON" position.**
- **When it is not played back normally, press the POWER/VOLUME knob twice while a USB cable is connected.**

▼ Overview

The Pandora operation screen can be reached by the following methods:

- Connecting a Pandora device. Refer to "Connecting a Bluetooth device" 82 or

"Connecting and disconnecting a USB memory/portable device" 5.

- Select **Pandora** (Pandora) on the "Select Audio Source (Select Audio Source)" screen. Refer to "Selecting an audio source" 12.

- Select **Pandora** (Pandora) on the "APPS (APPS)" screen. Refer to "STARLINK" 27.

Control screen

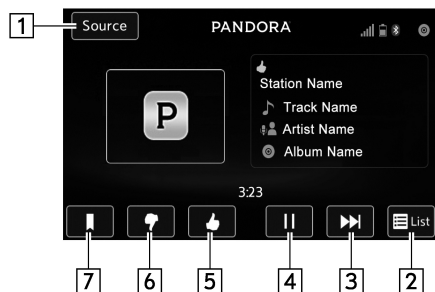

Control panel

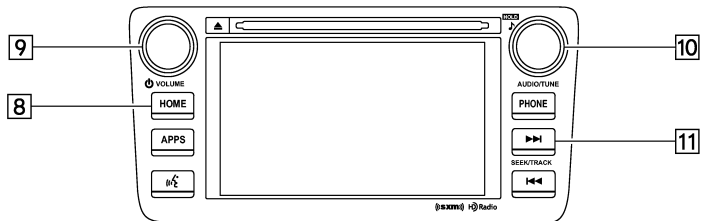

S01217

S02130

No.	Function
1	Select to display the audio source selection screen.
2	Select to open Station List.
3	Select to skip the current track.
4	Select to play back or pause a track. The Pause icon is displayed in the "Play/Pause" key during playback and the Playback icon is displayed in the "Play/Pause" key during pause.
5	Select to set Thumbs Up. This gives a high rating to the current song. All other similar songs will be played back more frequently.
6	Select to set Thumbs Down. This gives a low rating to the current song. All other similar songs will be played back less frequently. When you select Thumbs Down, the current track is skipped.
7	During playback of a station, you can use the "Bookmark Key" to bookmark a song or artist. The Bookmark Type Selection screen is displayed.
8	Select to display the sound setting screen. Refer to "Basic operation" 11.
9	Turn to adjust volume. Press to turn the audio system on/off.

No.	Function
10	Turn clockwise to skip to the next track.
11	Select  to skip to the next track/cover art.

Bookmark Type Selection screen

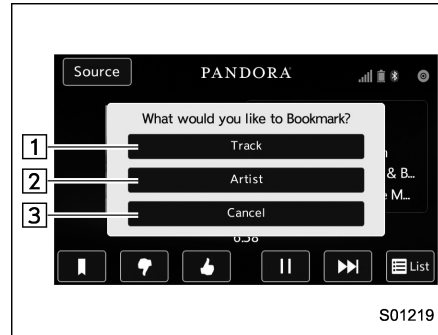

No.	Function
1	When selected after the Bookmark key is pressed, the current track is bookmarked.
2	When selected after the Bookmark key is pressed, the current artist is bookmarked.
3	Select to cancel the bookmark operation.

Control screen (Station list)

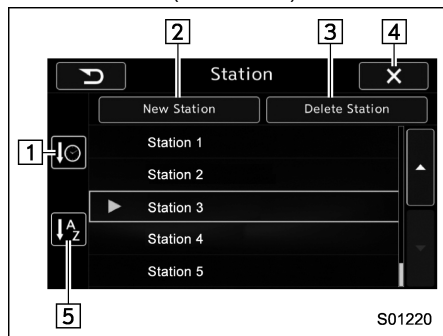

Control screen (New station)

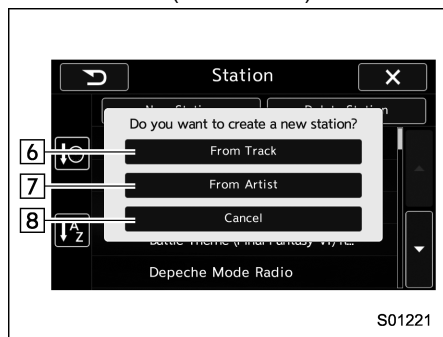

No.	Function
1	Select to sort the list in the chronological order of when the Station List was created.
2	Select to create a station. The station can be created using track names or artist names.
3	Select to delete a station.
4	Return to the control screen.
5	Select to sort the list based on the alphabetical order of the station names.
6	Select to create a station using a track name.
7	Select to create a station using an artist name.
8	Select to cancel the operation to create a station.

Control screen (Delete Station)

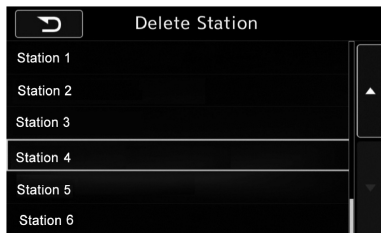

1

2

S01222

No.	Function
1	Select to delete the selected item from the list.
2	Select to cancel the operation to delete a station.

**WARNING**

Do not operate the player's controls or connect the smartphone while driving.

**CAUTION**

Do not leave your smartphone in the car. In particular, high temperatures inside the vehicle may damage the smartphone.

NOTE

Follow the specific operation procedures for the smartphone application.

Bluetooth® settings

■ Registering/connecting Bluetooth® device



The Bluetooth® word mark and logos are registered trademarks owned by Bluetooth SIG, Inc.

▼ Registering a Bluetooth phone for the first time

To use the hands-free system, it is necessary to register a Bluetooth phone with the system.

Once the phone has been registered, it is possible to use the hands-free system.

This operation cannot be performed while driving.

For details about registering a Bluetooth device: Refer to “Registering a Bluetooth device” 81.

1. Turn the Bluetooth connection setting of your cellular phone on.
 - This function is not available when Bluetooth connection setting of your cellular phone is set to off.
2. Select **HOME** and select **SETTINGS** (SETTINGS) to display the SETTINGS

screen.

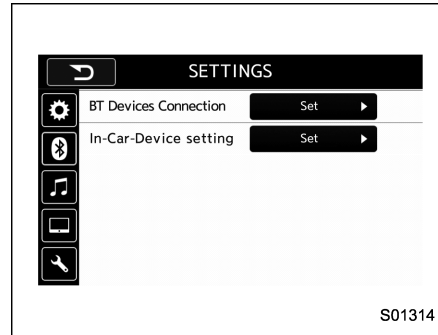

Settings (When selecting the “BT” tab)

3. To register a device, select “Add” on “BT Devices Connection”.

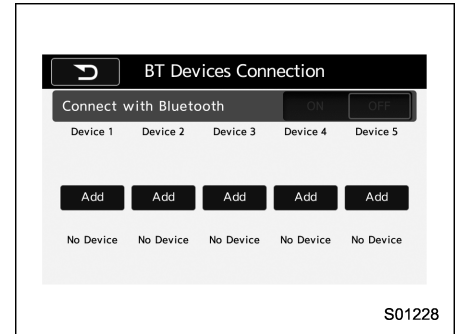

“BT Devices Connection” screen (At the initial startup and when no device is registered.)

4. When this screen is displayed, search for the device name displayed on this screen on the screen of your Bluetooth device.

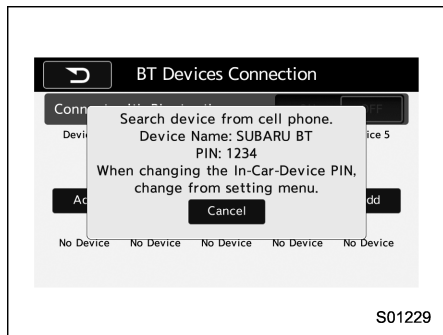

When “Add” is selected (Waiting for the connection request from a device).

- For details about operating the Bluetooth device, see the manual that comes with it.
 - To cancel the registration, select **Cancel** (Cancel).
5. Register the Bluetooth device using your Bluetooth device.
 - A PIN-code is not required for SSP (Secure Simple Pairing) compatible Bluetooth devices. Depending on the type of Bluetooth device being connected, a message confirming registration may be displayed on the Bluetooth device’s screen. Respond and operate the Bluetooth device according to the confirmation message.
 6. Check that the screen is displayed

when registration is complete.

- The system waits for connection requests coming from the registered device.
- At this stage, the Bluetooth functions are not yet available.

▼ Registering a Bluetooth Audio device for the first time

To use the Bluetooth Audio, it is necessary to register an audio device with the system.

Once the player has been registered, it is possible to use the Bluetooth Audio.

This operation cannot be performed while driving.

For details about registering a Bluetooth device: Refer to “Registering a Bluetooth device” 81.

The device registration procedure is the same for both the hands-free system and Bluetooth audio.

▼ Profiles

This system supports the following services.

Bluetooth Device	Spec.	Function	Requirements	Recommendations
Bluetooth Phone/Bluetooth Audio Device	Bluetooth Specification	Registering a Bluetooth device	Ver. 1.1	Ver. 2.1 + EDR

Bluetooth Device	Profile	Function	Requirements	Recommendations
Bluetooth Phone	HFP (Hands-Free Profile)	Hands-free system	Ver. 1.0	Ver. 1.5
	OPP (Object Push Profile)	Transferring the contacts	Ver. 1.1	Ver. 1.1
	PBAP (Phone Book Access profile)		Ver. 1.0	Ver. 1.0
	MAP (Message Access Profile)	Bluetooth phone message	—	Ver. 1.0
	SPP (Serial Port Profile)	Connecting a Bluetooth phone	—	Ver. 1.1
Bluetooth Audio Device	A2DP (Advanced Audio Distribution Profile)	Bluetooth audio system	Ver. 1.0	Ver. 1.2
	AVRCP (Audio/Video Remote Control Profile)		Ver. 1.0	Ver. 1.4

NOTE

- If your cellular phone does not support HFP, registering the Bluetooth phone or using OPP, PBAP, MAP or SPP profiles individually will not be possible.
- If the connected Bluetooth device version is older than recommended or incompatible, the Bluetooth device function may not work properly.
- For USA customers, please visit www.subaru.com for details. Outside of the USA customers, contact your local dealer to arrange a demonstration in order to confirm whether or not the device can be paired with the vehicle.

■ Setting Bluetooth details

1. Select **HOME**.

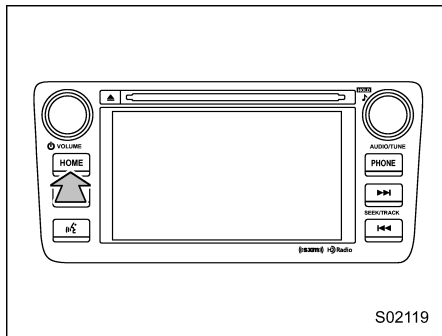

2. Select **SETTINGS** (SETTINGS).
3. To register a device, select “Add” on “BT Devices Connection”.

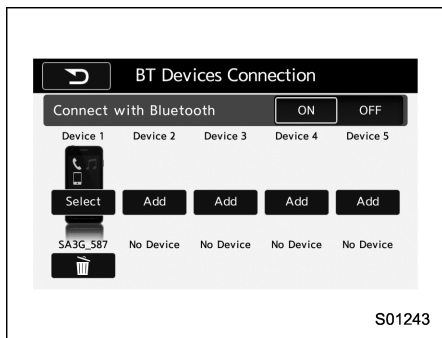

▼ BT Devices Connection screen

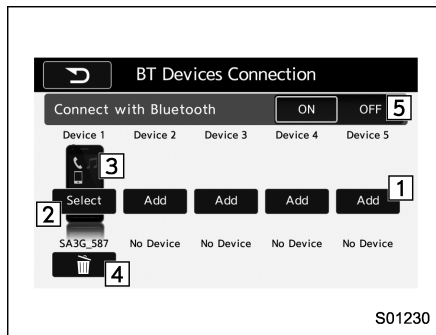

“BT Devices Connection” screen (One device is registered.)

No.	Function
1	“Add” key: Registers the device.
2	“Select” key: Makes the connection to the registered device.
3	This shows the status of the device connection profile. (The icon illuminates while connected.)
4	“Delete (Trash box)” key: Deletes the registered device.
5	Bluetooth ON/OFF key: Switches to connect/disconnect the Bluetooth communication.

Function	Page
Registering a Bluetooth device	81
Deleting a Bluetooth device	82
Connecting a Bluetooth device	82

▼ Registering a Bluetooth device

You can register up to five devices, regardless of whether they are Bluetooth phones or audio devices.

This operation cannot be performed while driving.

1. Display the “BT Devices Connection” screen. Refer to “Registering a Bluetooth phone for the first time” 78.

2. Select **Add** (Add).

The “Add” button is not displayed when five devices are already registered.

To add another device, you need to delete one of the registered devices.

Press and hold the Trash box icon for the device to be deleted, and then select “OK”.

3. Register the Bluetooth device using your Bluetooth device.

- A PIN-code is not required for SSP (Secure Simple Pairing) compatible Bluetooth devices. Depending on the type of Bluetooth device being connected, a message confirming regis-

tration may be displayed on the Bluetooth device's screen. Respond and operate the Bluetooth device according to the confirmation message.

4. Check that the screen is displayed when registration is complete.

- The system waits for connection requests coming from the registered device.
- At this stage, the Bluetooth functions are not yet available.

▼ Deleting a Bluetooth device

1. Display the "BT Devices Connection" screen. Refer to "Registering a Bluetooth phone for the first time" 78.

2. Select the desired device.

Press and hold the Trash box icon for the device to be deleted, and then select "OK".

NOTE

When deleting a Bluetooth phone, the contact data will be deleted at the same time.

▼ Connecting a Bluetooth device

Up to 5 Bluetooth devices (Phones (HFP) and audio devices (AVP)) can be registered.

If more than 1 Bluetooth device has been registered, select which device to connect to.

1. Display the "BT Devices Connection" screen. Refer to "Registering a Bluetooth phone for the first time" 78.

2. Select the device to be connected.

- Supported profile icons will be displayed.

–  : Phone

–  : Audio device

–  : Smartphone Application

- Supported profile icons for currently connected devices will illuminate.

- The Audio icon illuminates only when in the Bluetooth audio mode.

- All icons are dimmed when Bluetooth is set to OFF or when the connection cannot be made with the device.

NOTE

- It may take time if the device connection is carried out during Bluetooth audio playback.

- Depending on the type of Bluetooth device being connected, it may be necessary to perform additional steps on the device.

- It is not possible to establish a Bluetooth connection with iOS devices

currently connected with a USB cable.

▼ Bluetooth ON/OFF

1. Display the "BT Devices Connection" screen. Refer to "Registering a Bluetooth phone for the first time" 78.

2. Select the "Bluetooth ON/OFF" key.

- Select "ON" or "OFF" to connect/disconnect the Bluetooth communication. "ON" establishes a connection, and "OFF" disconnects the connection.

- The setting is fixed as "OFF" when no device is registered.

▼ "In-Car-Device setting" screen

The Bluetooth settings can be confirmed and changed.

1. Display the "SETTINGS" screen. Refer to "Registering a Bluetooth phone for the first time" 78.

2. On the SETTINGS for In-Car-Device setting select "set" key.

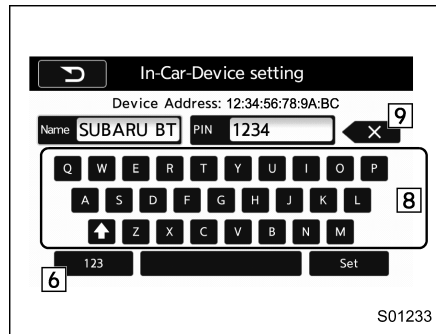
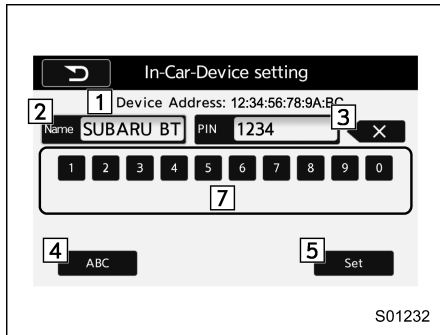
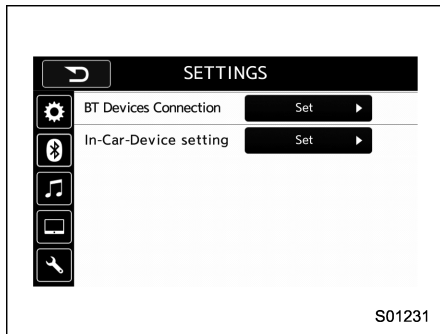

No.	Function
1	BT device address: Displays the Bluetooth device address of the in-vehicle equipment.
2	BT device name: Displays the Bluetooth device name of the in-vehicle equipment. The default name is "SUBARU BT", which can be changed by selecting it and entering alphanumeric characters.
3	PIN code: Displays the PIN code of the in-vehicle equipment. The default code is "1234", which can be changed by selecting it and entering numbers.
4	"ABC" key: Switches the screen to input alphabet characters. This key cannot be selected when entering the PIN code.
5	"Set" key: Saves the current BT device name and PIN code.

No.	Function
6	"123" key: Switches the screen to input numbers.
7	Numeric input keys.
8	Alphabet input keys. The up arrow key toggles the input between upper case and lower case characters.
9	"Delete" key: Deletes one character from the currently selected item (BT device name of the PIN code).

▽ Editing the Bluetooth Name

1. Select a BT device name.
2. Enter a name and then select "Set".

▽ Editing the PIN-Code

1. Select "PIN-Code".
2. Enter a PIN-code and then select "Set".

▽ Common operations

- Press the "Alphabet" key or "Number" key to make the changes.
- Press the "Set" key to set the entered value. The screen changes to the "Settings Bluetooth" screen.
- Press the "Back" key to discard the entered value. The screen returns to the "Settings Bluetooth" screen.

▽ **When the cursor is at the “Device Name Display Area”**

- The device name can be set or changed.
- Press the “PIN” key to enter a passcode.
- If the “PIN” key is already selected, the “Alphabet” key is cross-hatched and disabled.

▽ **When the cursor is at the “Passcode Display Area”**

- The passcode can be set/changed.
- Press the “Name” key to enter a device name.

Phone operation (Hands-free system for cellular phones)

■ Quick reference

The phone top screen can be used to make a phone call. To display the hands-free operation screen, select **PHONE** (PHONE), or press the **PHONE** button.

Several functions are available to operate on each screen that is displayed by selecting the 4 tabs.

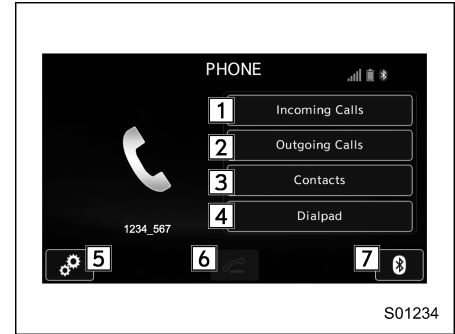

S01234

PHONE (Menu) screen



S01235

PHONE (Dialpad) screen

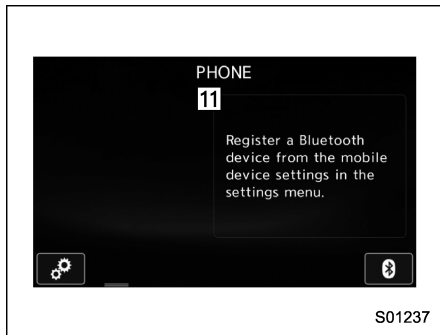
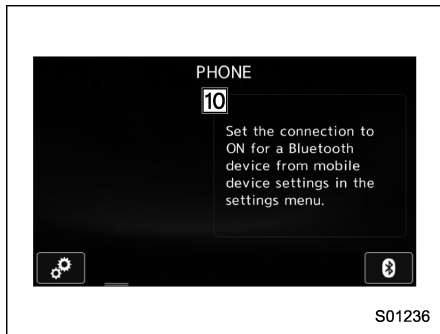

No.	Function
1	“Incoming Calls” key: Opens the Incoming Calls screen.
2	“Outgoing Calls” key: Opens the Outgoing Calls screen.
3	“Contacts” key: Opens the Contacts screen.
4	“Dialpad” key: Changes the screen from the Menu screen to the Dialpad screen.
5	“Option” key: Opens the phone volume setting screen.
6	“OFF Hook” key: Use to make a phone call. You cannot press this key until you open the Dialpad screen and enter a phone number.
7	“Bluetooth Setting” key: Opens the BT Devices Connection screen.
8	Enter the phone number that you want to call.
9	“Switch Screen” key: Switches the screen to the Phone (Menu) screen.
10	If no device is registered, a message is displayed instead of menu items.
11	

■ Some basics

The hands-free system enables calls to be made and received without having to take your hands off the steering wheel.

This system supports Bluetooth. Bluetooth

is a wireless data system that enables cellular phones to be used without being connected by a cable or placed in a cradle.

The operating procedure of the phone is explained here.



WARNING

- While driving, do not use a cellular phone or connect the Bluetooth phone.
- Your audio unit is fitted with Bluetooth antennas. People with implantable cardiac pacemakers, cardiac resynchronization therapy-pacemakers or implantable cardioverter defibrillators should maintain a reasonable distance between themselves and the Bluetooth antennas. The radio waves may affect the operation of such devices.
- Before using Bluetooth devices, users of any electrical medical device other than implantable cardiac pacemakers, cardiac resynchronization therapy-pacemakers or implantable cardioverter defibrillators should consult the manufacturer of the device for information about its opera-

tion under the influence of radio waves. Radio waves could have unexpected effects on the operation of such medical devices.

CAUTION

Do not leave your cellular phone in the vehicle. The temperature inside may rise to a level that could damage the phone.

NOTE

- If your cellular phone does not support Bluetooth, this system cannot function.
- In the following conditions, the system may not function:
 - The cellular phone is turned off.
 - The current position is outside the communication area.
 - The cellular phone is not connected.
 - The cellular phone has a low battery.
- When using the hands free function and other Bluetooth functions at the same time, the following problems may occur:
 - The Bluetooth connection may

be cut.

– Noise may be heard when playing back voice with the Bluetooth function.

▼ Registering/connecting a Bluetooth phone

To use the hands-free system for cellular phones, it is necessary to register a cellular phone with the system. Refer to “Registering/connecting Bluetooth® device” 78.

▽ Bluetooth phone condition display

The condition of the Bluetooth phone appears on the upper right side of the screen. Refer to “Bluetooth phone condition display” 86.

▼ Using the phone button/microphone

Phone button

By pressing the **PHONE** button, a call can be received or ended.

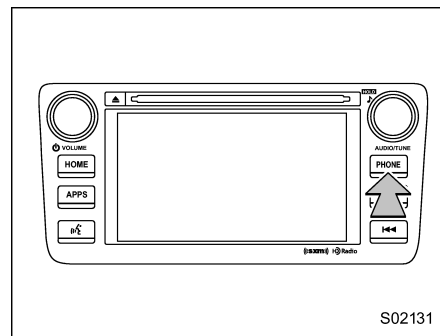

Microphone

The microphone is used when talking on the phone.

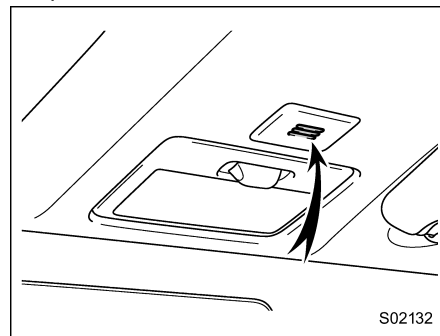

▼ Voice command system

Press this button to operate the voice command system.

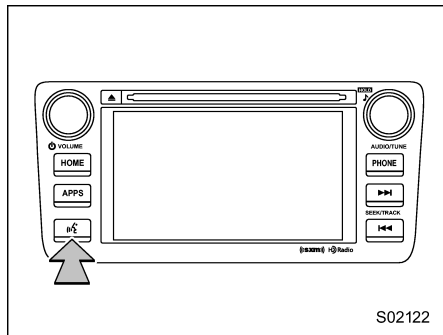

- The voice command system and its list of commands can be operated. Refer to “Voice command system operation” 105.

NOTE

- **The other party’s voice will be heard from the front speakers. The audio/visual system will be muted during phone calls or when hands-free voice commands are used.**
- Talk alternately with the other party on the phone. If both parties speak at the same time, the other party may not hear what has been said. (This is not a malfunction.)

- **Keep call volume down. Otherwise, the other party’s voice may be audible outside the vehicle and voice echo may increase. When talking on the phone, speak clearly towards the microphone.**
- **The other party may not hear you clearly when:**
 - Driving on an unpaved road. (Making excessive traffic noise.)
 - Driving at high speeds.
 - The roof or windows are open.
 - The air conditioning vents are pointed towards the microphone.
 - The sound of the air conditioning fan is loud.
 - There is a negative effect on sound quality due to the phone and/or network being used.

▼ About the contacts in the contact list

- The following data is stored for every registered phone. When another phone is connected, the following registered data cannot be read:
 - Contact data

NOTE

When a phone’s registration is deleted, the above-mentioned data is also deleted.

▼ When selling or disposing of the vehicle

A lot of personal data is registered when the hands-free system is used. When selling or disposing of the vehicle, initialize the data. Refer to “Other settings” 9.

- The following data in the system can be initialized:
 - Contact data

NOTE

Once initialized, the data and settings will be erased. Pay much attention when initializing the data.

■ Calling on the Bluetooth phone

After a Bluetooth phone has been registered, a call can be made using the hands-free system. There are several methods by which a call can be made, as described below.

1. Press **PHONE** button.

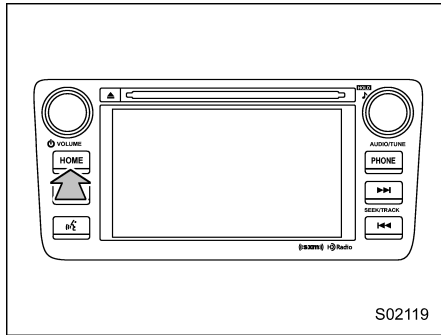

2. Select the desired tab to call from.

- On the PHONE screen, select “Incoming Calls” to open the Incoming Calls screen. Refer to “Quick reference” 84.

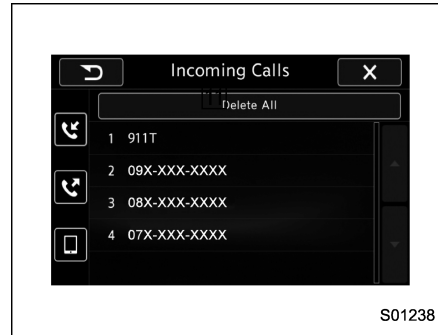

Incoming Calls screen

- On the PHONE screen, select “Outgoing Calls” to open the Outgoing Calls screen. Refer to “Quick reference” 84.

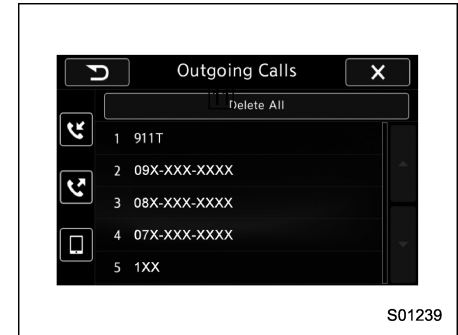

Outgoing Calls screen

- On the PHONE screen, select “Contacts” to open the Contacts screen. Refer to “Quick reference” 84.

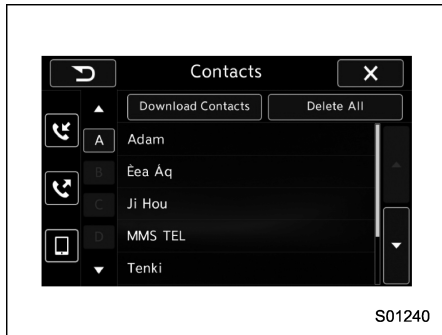

Contacts screen

- On the PHONE screen, select “Dialpad” to open the Dialpad screen. Refer to “Quick reference” 84.

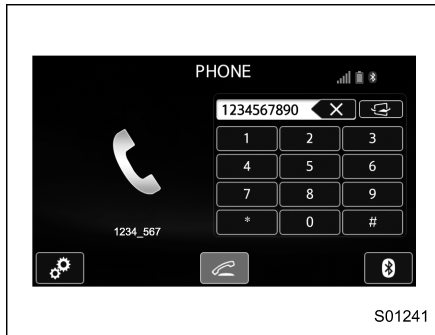

PHONE (Dialpad) screen

How to make a call list	Page
By call history	89
By contacts list	91
By dialpad ^{*1}	94
“OFF_hook” key	94
By voice command system	105

^{*1}: The operation cannot be performed while driving.

▼ By call history

▽ Incoming Calls

- On the PHONE screen, select “Incoming Calls” to open the Incoming Calls screen.
- Up to ten items in the incoming call history are listed. Scroll the screen to see items that are not on the screen.
- You can make a call by selecting an item in the incoming call history list.

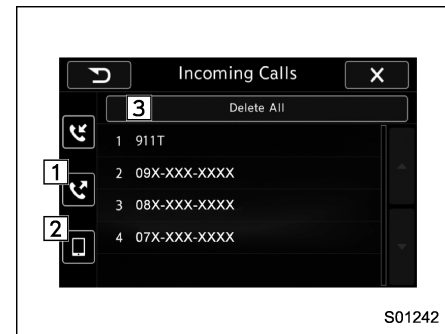

Incoming Calls screen

- If there is no incoming call history, a message appears to indicate that there is no incoming call history data.

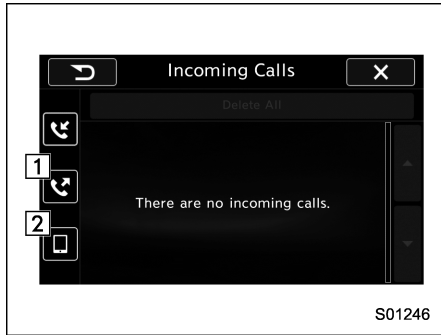

Incoming Calls screen (No incoming call history)



Incoming Calls screen (Confirmation to delete incoming call history)

No.	Function
1	"Outgoing Calls" key: Opens the Outgoing Calls screen.
2	"Contacts" key: Opens the Contacts screen.
3	"Delete All" key: Deletes all incoming call history data. The "Delete All" key is disabled when there is no incoming call history.
4	"OK" key: Deletes incoming call history.
5	"Cancel" key: Cancels the deletion of incoming call history. The screen returns to the Incoming Calls screen.

NOTE

- When making a call to the same number continuously, only the most recent call is listed in call history.
- When a phone number registered in the contact list is received, the name is displayed.
- Number-withheld calls are also memorized in the system.
- International phone calls may not be made depending on the type of cellular phone you have.
- The list should group together consecutive entries with the same phone number and same call type.

▽ Outgoing Calls

- On the PHONE screen, select "Outgoing Calls" to open the Outgoing Calls screen.
- Up to ten items in the outgoing call history are listed. Scroll the screen to see items that are not on the screen.
- You can make a call by selecting an item in the outgoing call history list.
- If there is no outgoing call history, a message appears to indicate that there is no outgoing call history data.

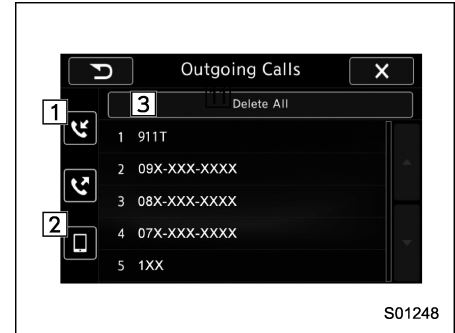

Outgoing Calls screen

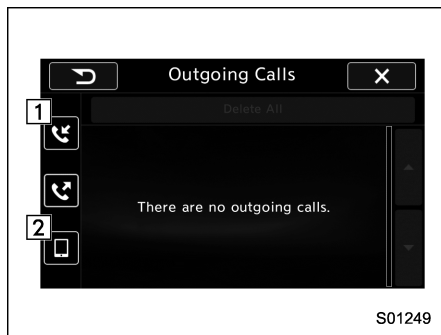

Outgoing Calls screen (No outgoing call history)

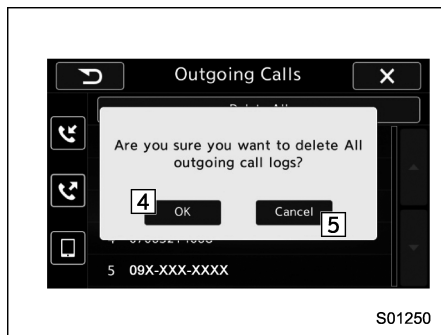

Outgoing Calls screen (Confirmation to delete outgoing call history)

No.	Function
1	“Incoming Calls” key: Opens the Incoming Calls screen.
2	“Contacts” key: Opens the Contacts screen.
3	“Delete All” key: Deletes all outgoing call history data. The “Delete All” key is disabled when there is no outgoing call history.
4	“OK” key: Deletes outgoing call history.
5	“Cancel” key: Cancels to delete outgoing call history. The screen will go back to the Outgoing Calls screen.

NOTE

- When making a call to the same number continuously, only the most recent call is listed in call history.
- When a phone number registered in the contact list is received, the name is displayed.
- Number-withheld calls are also memorized in the system.
- International phone calls may not be made depending on the type of cellular phone you have.
- The list should group together consecutive entries with the same phone number and same call type.

▼ By contacts list

- Up to 1000 items in the contact data are listed. Scroll the screen to see items that are not on the screen.
- Select an item in the contact list to open the Phone Number List screen.
- You can make a call by selecting an item in the phone number list (up to five phone numbers are listed).
- If there is no contact data, a message is displayed to indicate that there is no contact data.

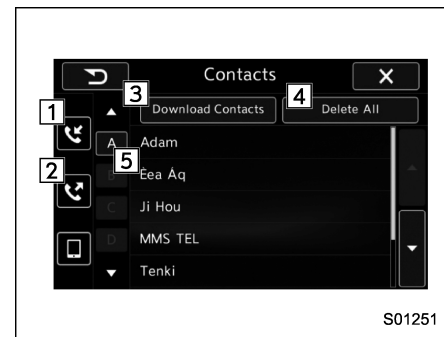

Contacts screen



S01252

Phone Number List screen (Example when “Adam” is selected)

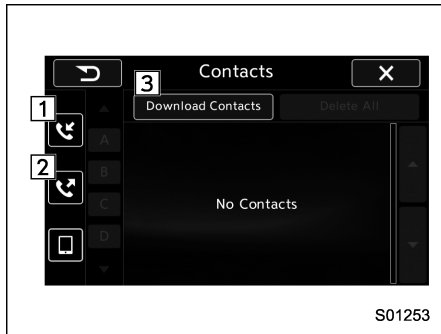

S01253

Contacts screen (When there is no data)

No.	Function
1	“Incoming Calls” key: Opens the Incoming Calls screen.
2	“Outgoing Calls” key: Opens the Outgoing Calls screen.
3	“Download Contacts” key: Opens a pop-up screen for starting the download of contact data.
4	“Delete All” key: Deletes all contact data. The “Delete All” key is disabled when there is no contact data.
5	“Search” key: Opens a list of contacts that starts with the selected character. This key is cross-hatched and cannot be selected if there is no contact data that starts with the selected character,

Select the up/down arrow key to scroll the “Search” key.

▽ When the contact is empty For PBAP incompatible but OPP compatible Bluetooth phones

- On the Contacts screen, select “Download Contacts”. A screen where you can select how to download contacts opens.
- You can select to download all items or download one item.

*: To download all items, you may need to change the settings in your cellular phone beforehand.

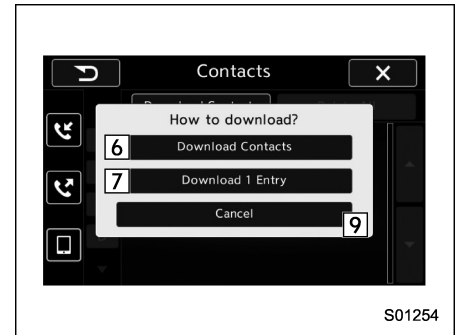

S01254

Contacts screen (Download selection)



S01255

Contacts screen (Download confirmation)

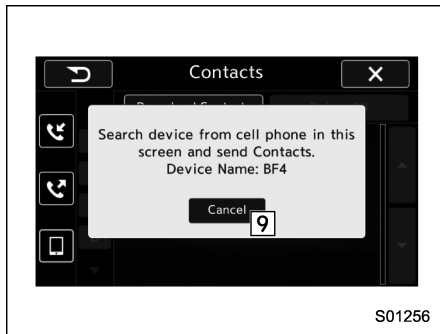

S01256

Contacts screen (Download confirmation)

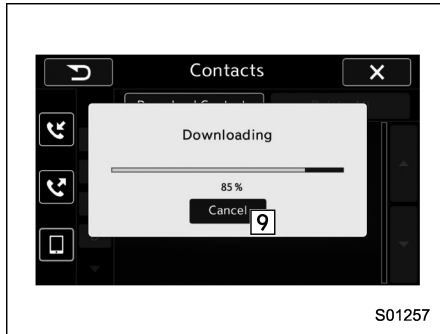

S01257

Contacts screen (Download in progress)

No.	Function
6	“Download Contacts” key: Opens the Download Confirmation screen. Confirm whether or not to download. If the downloaded contact(s) already exist(s), confirm whether or not to overwrite the existing data.
7	“Download 1 Entry” key: Downloads one set of contact data. To download the data, you need to operate from the connected device.
8	“OK” key: Starts downloading all contacts.
9	“Cancel” key: Cancels the download. The screen returns to the Contacts screen. (The pop-up screen disappears.)

- All contact data downloaded into the in-vehicle equipment will be deleted.



S01263

Contacts screen (Confirmation to delete contact data)

No.	Function
10	“OK” key: Deletes all downloaded contact data.
11	“Cancel” key: Cancels the deletion. The screen returns to the Contacts screen.

NOTE

- Manual transfer operation cannot be performed while driving.
- If your cellular phone is neither PBAP nor OPP compatible, the contacts cannot be transferred.
- Depending on the type of Bluetooth phone:
 - It may be necessary to perform additional steps on the phone when

– CONTINUED –

transferring contact data.

▼ By Dialpad

The Outgoing Call screen opens when you perform the following operations.

- When you enter a phone number on the PHONE (Dialpad) screen and select the “OFF_Hook” key, the Outgoing Call screen opens.
- When you select an item in the incoming call history list on the Incoming Calls screen, the Outgoing Call screen opens.
- When you select an item in the outgoing call history list on the Outgoing Call screen, the Outgoing Call screen opens.
- When you select a phone number on the Contacts (Phone Number List) screen, the Outgoing Call screen opens.

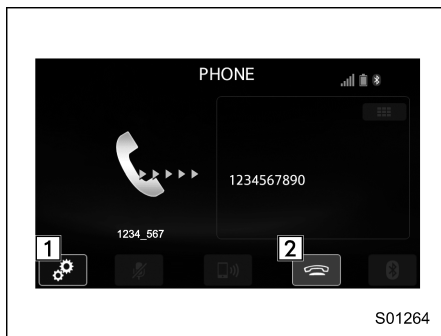

Outgoing Call screen

No.	Function
1	“Option” key: Opens the Options (volume settings) screen.
2	“ON_Hook” key: Aborts the call. The screen returns to the Phone (Menu) screen.

NOTE

Depending on the type of Bluetooth phone being connected, it may be necessary to perform additional steps on the phone.

▼ By phone button

1. Press the **PHONE** button to display the phone top screen.
2. Check that the “Call (Call)” screen is displayed.

■ Receiving on the Bluetooth phone

▼ Incoming calls

When a call is received, the incoming call screen is displayed with a sound.

- When you are on the Outgoing Call screen, the screen changes to the Call screen when the other party answers the call.
- The “Mute”, “Speaker”, and “Bluetooth” keys are disabled on the Outgoing Call screen.
- When you receive a phone call while the cellular phone is connected, the screen changes to the Incoming Call screen.

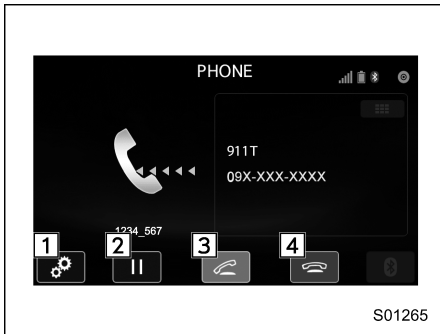

Incoming Call screen



Unable to put call on hold screen

No.	Function
1	“Option” key: Opens the Options (volume settings) screen.

No.	Function
2	“Hold” key: Puts the incoming call on hold. This function may not work on some cell phone models.
3	“OFF_Hook” key: Opens the Call screen.
4	“ON_Hook” key: Rejects the incoming call.

NOTE

- During international phone calls, the other party’s name or number may not be displayed correctly depending on the type of cellular phone you have.
- The call and ringtone volume that has been adjusted in the **Sound Settings** (Sound Settings) screen sounds when there is an incoming call. Depending on the type of Bluetooth phone, both the system and Bluetooth phone may sound simultaneously when there is an incoming call. Refer to ““Sound Settings (Sound Settings)” screen” 97.

■ Talking on the Bluetooth phone

While talking on the phone, this screen is displayed. The operations outlined below can be performed on this screen.

- When the Incoming Call screen is displayed and you accept the call, the screen changes to the Call screen. The screen stays on the Incoming Call screen if you reject the call.
- The “Dialpad” and “Bluetooth Setting” keys are disabled on the Incoming Call screen.

The Call screen opens when you perform the following operations.

- When you accept a call on the Incoming Call screen (by selecting the “OFF_Hook” key), the Call screen opens.
- When you are on the Outgoing Call screen, the screen changes to the Call screen when the other party answers the call.

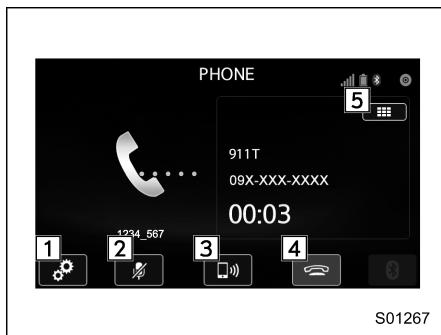

Call screen

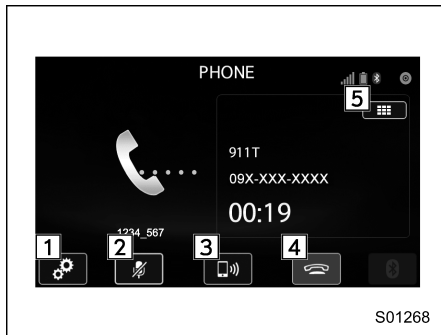

Call screen (Your voice Mute ON)

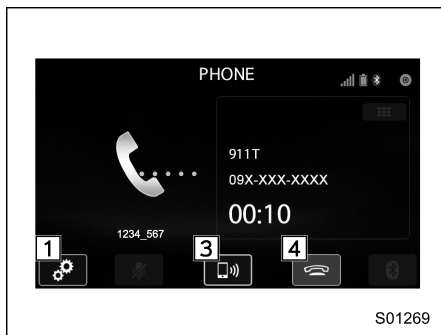

Call screen (Private ON)



Call (Dialpad) screen (DTMF)

No.	Function
1	“Option” key: Opens the Options (volume settings) screen.

No.	Function
2	“Mute” key: Mutes your voice to the other party. Press the “Mute” key again to deactivate the Mute mode. This key is disabled in the Private mode.
3	“Speaker” key: Changes the mode to Private mode. The other party’s voice emits from the cell phone. Press the “Speaker” key again to deactivate the Private mode.
4	“ON Hook” key: Ends the call. You return to the Phone (Menu) screen when ending outgoing calls and the previous screen when ending incoming calls.
5	“Dialpad” key: Opens the Call (Dialpad) screen.
6	“Switch Screen” key: Switches the screen to the Phone (Menu) screen.
7	“Dialpad” key: Allows you to make DTMF (Dual Tone Multi Frequency) calls. The numbers you enter are sent as tone signals.

NOTE

- When cellular phone call is changed to hands-free call, the hands-free screen will be displayed and its functions can be operated on the screen.
- Changing between cellular phone call and hands-free call can be performed by operating the cellular phone directly.

- Transferring methods and operations will be different depending on the type of cellular phone you have.
- For the operation of the cellular phone, see the manual that comes with it.

- On the PHONE (Menu) screen, the screen changes to the Phone (Dialpad) screen when you select “Dialpad”.
- After entering the phone number on the keypad, the call is made when you select the “OFF_Hook” key.

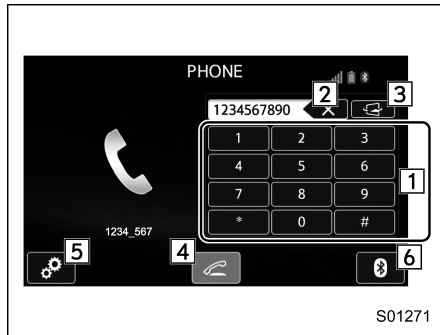

Phone (Dialpad) screen

No.	Function
1	“Dialpad” keys: Allows you to enter numbers from 0 to 9 and *, #, and +. To enter “+”, press and hold the “0” key.
2	“Delete” key: Deletes one character from the entered characters.
3	“Switch Screen” key: Switches the screen to the Phone (Menu) screen.
4	“OFF_Hook” key: Opens the Outgoing Calls screen and dials the entered phone number. This key is cross-hatched and cannot be selected until the phone number is entered.
5	“Option” key: Opens the Options (volume settings) screen.
6	“Bluetooth Setting” key: Opens the BT Devices Connection screen.

NOTE

The sound quality of the voice heard from the other party’s speaker may be negatively impacted.

Setup

■ Phone settings

▼ “Sound Settings (Sound Settings)” screen

The call and ringtone volume can be adjusted. A ringtone can be selected.

1. Display the “PHONE” screen. Refer to “Quick reference” 84.
2. Select **Option** (Option).
3. Select the desired item to be set.

- Select to adjust the volume of the telephone function.
- On the PHONE screen, the screen changes to the Options screen when you select the “Option” key.

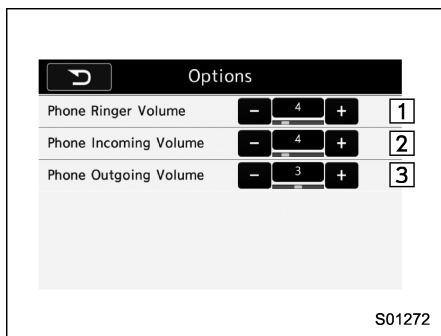

Options (volume settings) screen

No.	Function
1	Phone Ringer Volume +/- keys: Adjusts the ringtone volume. The “-” key lowers the volume, and the “+” key increases the volume. (Default volume: 4 out of a total of 16 volume levels)
2	Phone Incoming Volume +/- keys: Adjusts the receive volume. The “-” key lowers the volume, and the “+” key increases the volume. (Default volume: 4 out of a total of 16 volume levels)
3	Phone Outgoing Volume +/- keys: Adjusts the transmit volume. The “-” key lowers the volume, and the “+” key increases the volume. (Default volume: 3 out of a total of 5 volume levels)

NOTE

• Depending on the type of phone, certain functions may not be available.
 • Contact data is managed independently for every registered phone. When one phone is connected, another phone’s registered data cannot be read.

▼ Update contacts from phone

Operation methods differ between PBAP compatible and PBAP incompatible but OPP compatible Bluetooth phones.

If your cellular phone is neither PBAP nor OPP compatible, the contacts cannot be transferred.

For PBAP compatible Bluetooth phones

1. Select **Download Contacts** (Download Contacts).
 - Contacts are transferred automatically.
2. Check that a confirmation screen is displayed when the operation is complete.
 - This operation may be unnecessary depending on the type of cellular phone.

- If another Bluetooth device is connected when transferring contact data, depending on the phone, the connected Bluetooth device may need to be disconnected.
- Depending on the type of Bluetooth phone being connected, it may be necessary to perform additional steps on the phone.

For PBAP incompatible but OPP compatible Bluetooth phones

This operation cannot be performed while driving.

1. Select **Download Contacts** (Download Contacts).
Select Download 1 Entry.
2. Transfer the contact data to the system using a Bluetooth phone.
 - This operation may be unnecessary depending on the type of cellular phone.
 - To cancel this function, select **Cancel** (Cancel).
3. Check that a confirmation screen is displayed when the operation is complete.

▼ Deleting the contact data

1. Select **Delete All** (Delete All).
2. Select **OK** (OK) when the confirmation screen appears.

Refer to “By contacts list”  91.

NOTE

For deleting data, all items are deleted.

What to do if...

■ Troubleshooting

If there is a problem with the hands-free system or a Bluetooth device, first check the table below.

When using the hands-free system with a Bluetooth device

Symptom	Likely cause	Solution	Page	
			Cellular phone	This system
The hands-free system or Bluetooth device does not work.	The connected device may not be a compatible Bluetooth cellular phone.	For USA customers, please visit www.subaru.com for details. Outside of the USA customers, contact your local dealer to arrange a demonstration in order to confirm whether or not the device can be paired with the vehicle.	*	—
	The Bluetooth version of the connected cellular phone may be older than the specified version.	Use a cellular phone with Bluetooth version 1.1 or higher (recommended: Ver. 2.1 + EDR or higher).	*	80

*: For details, refer to the owner's manual that came with the cellular phone.

When registering/connecting a cellular phone

Symptom	Likely cause	Solution	Page	
			Cellular phone	This system
A cellular phone cannot be registered.	An incorrect passcode was entered on the cellular phone.	Enter the correct passcode on the cellular phone.	*	—
	The registration operation has not been completed on the cellular phone side.	Complete the registration operation on the cellular phone (approve registration on the phone).	*	—
	Old registration information remains on either this system or the cellular phone.	Delete the existing registration information from both this system and the cellular phone, then register the cellular phone you wish to connect to this system.	*	81
A Bluetooth connection cannot be made.	Another Bluetooth device is already connected.	Manually connect the cellular phone you wish to use to this system.	—	81
	Bluetooth function is not enabled on the cellular phone.	Enable the Bluetooth function on the cellular phone.	*	—
	Automatic Bluetooth connection on this system is set to off.	Set automatic Bluetooth connection on this system to on when the ignition switch is turned to the "ACC" or "ON" position.	—	81
"Unable to dial. Please check your phone. (Unable to dial. Please check your phone.)"	Bluetooth function is not enabled on the cellular phone.	Enable the Bluetooth function on the cellular phone.	*	—
	Old registration information remains on either this system or the cellular phone.	Delete the existing registration information from both this system and the cellular phone, then register the cellular phone you wish to connect to this system.	*	81

*: For details, refer to the owner's manual that came with the cellular phone.

When making/receiving a call

Symptom	Likely cause	Solution	Page	
			Cellular phone	This system
A call cannot be made/received.	Your vehicle is in a "No Service (No Service)" area.	Move to where "No Service (No Service)" no longer appears on the display.	—	—

When using the phonebook

Symptom	Likely cause	Solution	Page	
			Cellular phone	This system
Phonebook data cannot be transferred manually.	The profile version of the connected cellular phone may not be compatible with transferring phonebook data.	For USA customers, please visit www.subaru.com for details. Outside of the USA customers, contact your local dealer to arrange a demonstration in order to confirm whether or not the device can be paired with the vehicle.	*	—
	Transfer operation on the cellular phone has not completed.	Complete transfer operation on the cellular phone (approve transfer operation on the phone).	*	—
Phonebook data cannot be edited.	Editing function is not available on this system.	—	—	99

*: For details, refer to the owner's manual that came with the cellular phone.

In other situations

Symptom	Likely cause	Solution	Page	
			Cellular phone	This system
Even though all conceivable measures have been taken, the symptom status does not change.	The cellular phone is not close enough to this system.	Bring the cellular phone closer to this system.	—	—
	The cellular phone is the most likely cause of the symptom.	Turn the cellular phone off, remove and reinstall the battery pack, and then restart the cellular phone.	*	—
		Enable the cellular phone's Bluetooth connection.	*	—
		Stop the cellular phone's security software and close all applications.	*	—
		Before using an application installed on the cellular phone, carefully check its source and how its operation might affect this system.	*	—

*: For details, refer to the owner's manual that came with the cellular phone.

Voice command system operation

■ Voice command system

The voice command system enables the audio, hands-free systems, etc. to be operated using voice commands.

Refer to the “Command list” 107 for samples of voice commands.

▼ Using the voice command system

▽ Talk button

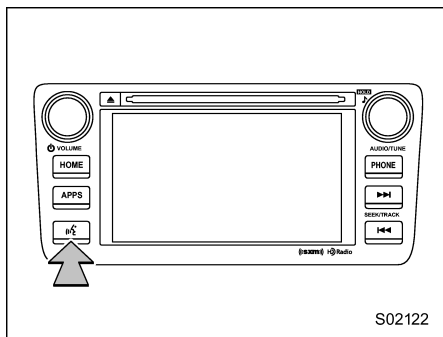

- Press the talk button to start the voice command system.
- To cancel voice recognition, press and hold the talk button.

▽ Microphone

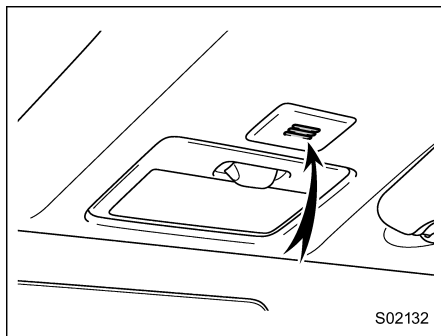

- It is unnecessary to speak directly into the microphone when giving a command.

NOTE

- Wait for the confirmation beep before speaking a command.
- Voice commands may not be recognized if:
 - Spoken too quickly.
 - Spoken at a low or high volume.
 - The roof or windows are open.
 - Passengers are talking while voice commands are spoken.
 - The air conditioning speed is set high.
 - The air conditioning vents are turned towards the microphone.
- In the following conditions, the sys-

tem may not recognize the command properly and using voice commands may not be possible:

- The command is incorrect or unclear. Note that certain words, accents or speech patterns may be difficult for the system to recognize.
- There is excessive background noise, such as wind noise.

▼ Voice command system operation

1. Press the talk button.
 - After the voice command top screen has been displayed, speech guidance will commence.

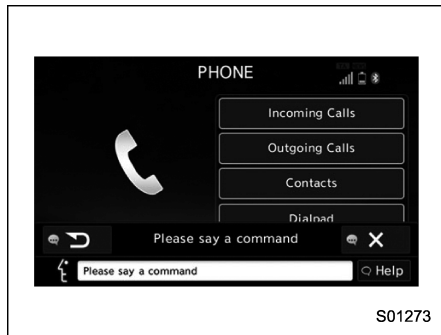

NOTE

When the voice command mode is audio mode, voice guidance for the voice command system can be skipped by pressing the talk button.

2. Say the command.
 - Say "Help" or "Phone".

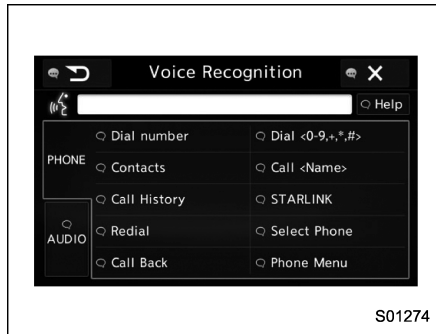

- Say "Audio".

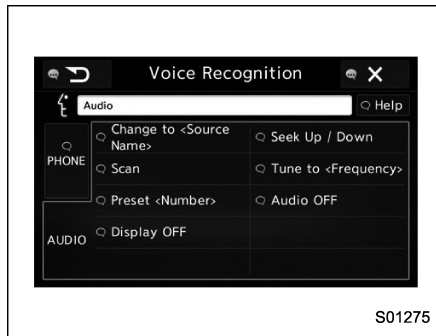

- Commands related with each function are displayed on the screen of the each function tab. Some commonly

used commands are displayed on the screen of the main tab. Even if any tab is selected, all commands can be operated.

- Saying **Help** (Help) prompts guidance to offer examples of commands and operation methods.
- To cancel voice recognition, select "×", or press and hold the talk button.

NOTE

If the system does not respond or the confirmation screen does not disappear, press the talk button and try again.

▽ Voice command example: Call name

1. Press the talk button.
2. Say "**Call <contacts>**".
 - A confirmation screen will be displayed showing the recognition results. If multiple matching items are found, a selection screen will be displayed. Say "**<number>**" or select the number.

NOTE

- In the same manner as it is displayed on the screen, "**Call <contacts>**" (Call <contacts>), after saying

“Call a contact” say the name of a contact. For example: **“Call a contact”, “John Smith”** or **“Call a contact”, “Mary Davis”**

- Short or abbreviated names in the contacts list may not be recognized. Change names in the contacts list to full names.

- Sometimes a voice recognition result confirmation screen will be displayed. After confirming the result, say **“Yes”** or **“No”**.

- When the system recognizes multiple names from the contacts list, a name candidate list will be displayed on the screen. If the desired name is not displayed on the top of the screen, say or select the number of the name from the candidate list (number 1, number 2, etc.) to select a name from the candidate list.

- When a contact has multiple phone numbers registered in the contacts list, a candidate list will be displayed. If the desired phone number is not displayed on the top of the screen, say or select the number of the desired phone number from the candidate list (number 1, number 2, etc.) to select a phone number from the candidate list.

▽ Voice command example: Dial number

1. Press the talk button.
2. Say the phone number.
 - In the same manner as it is displayed on the screen, **“Dial <number>”** (Dial <number>), after saying **“Dial a number”** say the phone number.
 - Say the phone number one digit at a time.

For example, if the phone number is 2345678:

Say **“two three four five six seven eight”**

Do not say **“twenty three forty five sixty seven eight”**

Calling to the following phone numbers

- 3 digit numbers (911, 411, 611)
- 7 digit numbers (Local phone numbers)
- 10 digit numbers (Area code + Local phone number)
- 11 digit phone numbers (1 + Area code + Local phone number)
- As the system cannot recognize additional numbers, say the complete number without stopping.

Calling to other phone numbers

3. Say **“Dial”** or press the **PHONE** button.
 - When the system recognizes multiple phone numbers, a phone number candidate list will be displayed on the screen. Pressing the **PHONE** button makes a call to the top entry on the list. If the desired phone number is not displayed on the top of the screen, say the number of the desired phone number from the candidate list to select a phone number from the candidate list.

▼ Casual speech recognition

Due to natural language speech recognition technology, this system enables recognition of a command when spoken naturally. However, the system cannot recognize every variation of each command. In some situations, it is possible to omit the command for the procedure and directly state the desired operation. Not all voice commands are displayed in the function menu.

NOTE

If the command cannot be recognized completely, the command input screen will be displayed. (Search results will be shown based on the part of the command that was recognized.)

▽ **Expression examples for each function**

Command	Expression examples
"Dial <phone number>"	<i>Phone <phone number>.</i>

Command list

Recognizable voice commands and their actions are shown below.

- Some voice commands may not be available depending on the countries, vehicle specifications or the device connection status.
- Frequently used commands are listed in the following tables.
- For devices that are not installed in the vehicle, the related commands will not be displayed in the screen. Also, according to conditions, other commands may not be displayed in the screen.
- The functions available may vary according to the system installed.
- Voice recognition language can be changed. Refer to "Other settings" 9.

NOTE

- **The notations used in the commands are as follows.**
 - [000]: **Commands that need not to be spoken**
 - <000>: **Numbers, titles, or names to be spoken**

Basic command

Voice command	Phrase	Function
System back	Back	Go back one hierarchy or cancel the voice recognition (voice command top screen)
System help	Help	Ask for help with the current task
System cancel (Close)	Cancel, Close	Cancel the current task
Yes	Yes	
No	No	
Display OFF	Display OFF	Turns the display off
Audio ON	Audio ON	Turns the audio system on
Audio OFF	Audio OFF	Turns the audio system off
STARLINK mode change	STARLINK	Switch to APPS mode

Commands for changing the radio mode

Voice command	Phrase	Function
AM mode change	Change to AM	Switch to AM mode
	Change to AM1	Switch to AM mode band 1
	Change to AM2	Switch to AM mode band 2
FM mode change	Change to FM	Switch to FM mode
	Change to FM1	Switch to FM mode band 1
	Change to FM2	Switch to FM mode band 2
	Change to FM3	Switch to FM mode band 3
SXM radio mode change	Change to SiriusXM	Switch to XM mode
Bluetooth Audio mode change	Change to BT Audio	Switch to Bluetooth Audio mode
CD mode change	Change to CD	Switch to CD mode
USB mode change	Change to USB	Switch to USB mode
iPod mode change	Change to iPod	Switch to iPod mode
Aha radio mode change	Change to Aha	Switch to Aha radio mode

Voice command	Phrase	Function
Pandora mode change	Change to Pandora	Switch to Pandora mode
AUX mode change	Change to AUX	Switch to AUX mode

Commands for Hands Free

Voice command	Phrase	Function
Dial number calling	Dial Number → <0-9, +, *, #> → Change number, Dial	Places a call to the said phone number
	Dial <0-9, +, *, #> → Change number, Dial	
Contacts (Phonebook)	Contacts, Phonebook → <Name> → <1-5> → Dial	Make a call by using the phonebook
Call <Name>	Call <Name> → <1-5> → Dial	

Voice command	Phrase	Function
Recent calls	Call History → Incoming call, Outgoing call → Next (page), Previous (page) → <1-5> → Dial	Make a call by using the call history
Incoming calls	Incoming Calls	Display the call history screen
Outgoing calls	Outgoing Calls	Display the call history screen
Redial	Redial	Places a call to the phone number of the latest outgoing call
Callback	Callback	Places a call to the phone number of the latest incoming call
Select phone	Select Phone → <1-5>	Display the phone select screen
Show phone menu	Phone Menu	Display the hands free top screen

Commands for Pandora

Voice command	Phrase	Function
Like	Like	Mark "Like" flag
Dislike	Dislike	Mark "Dislike" flag
Skip	Skip, Next	Skip to the next song

Commands for aha

Voice command	Phrase	Function
Thumbs up	Thumbs Up, Heart, Like	Mark "Like" flag
Thumbs down	Thumbs Down, Ban, Dislike	Mark "Dislike" flag
Update	Refresh	Refresh the selected station to get the latest information
Content up	Content Up	Playback next Content
Content down	Content Down	Playback previous Content

Commands for AM/FM control

Voice command	Phrase	Function
Seek up	Seek Up	Tunes in the higher frequency direction
Seek down	Seek Down	Tunes in the lower frequency direction
Scan	Scan	Switch to the scan mode
Direct frequency tuning	Tune to <Frequency>	Designate the frequency to switch to a specific radio station
Preset number tuning	Preset <pre-set number>	Designate the preset channel to switch to specific radio station
Tag	Tag	iTunes Tagging for HD Radio

Commands for SiriusXM radio control

Voice command	Phrase	Function
Preset number tuning	Preset <pre-set number>	Designate the preset channel to switch to specific radio station
Scan	Scan	Switch to the scan mode
Channel number tuning	Channel <Channel number>	Designate the channel to switch to specific radio station
Category	Category	Displays the category list screen

Commands for CD control

Voice command	Phrase	Function
Track up, next track	Track Up	Select the next track
Track down, previous track	Track Down	Select the current track
Scan	Scan	Switch to the scan mode
1 Track Repeat	1 Track Repeat	Repeat single track
Repeat All	Repeat All	Repeat all tracks
Shuffle	Shuffle	Plays randomly

Commands for MP3/WMA/AAC, USB control

Voice command	Phrase	Function
Track up, next track	Track Up	Select the next track
Track down, previous track	Track Down	Select the current track
Folder up	Folder Up	Plays from the start of the next folder

Voice command	Phrase	Function
Folder down	Folder Down	Plays from the start of the previous folder
Scan	Scan	Switch to the scan mode
1 track repeat	1 Track Repeat	Repeat single track
Repeat folder	Repeat Folder	Repeat of the folder
Repeat all	Repeat All	Repeat all tracks
Shuffle folder	Shuffle Folder	Plays randomly of the folder
Shuffle all	Shuffle All	Plays randomly

Commands for iPod control

Voice command	Phrase	Function
Track up, next track	Track Up	Select the next track
Track down, previous track	Track Down	Select the current track
Repeat one	Repeat One	Repeat single track
Repeat all	Repeat All	Repeat all tracks
Shuffle track	Shuffle Track	Shuffle all tracks
Shuffle album	Shuffle Album	Shuffle all tracks
Shuffle OFF	Shuffle OFF	Turn off shuffle

Commands for Bluetooth audio control

Voice command	Phrase	Function
Pause	Pause	Pause play
Track up, next track	Track Up	Select the next track
Track down, previous track	Track Down	Select the current track
1 Track repeat	1 Track Repeat	Repeat single track
Repeat all	Repeat All	Repeat all tracks
Group repeat	Group Repeat	Repeat tracks on group
Shuffle all	Shuffle All	Shuffle all tracks
Group shuffle	Group Shuffle	Shuffle tracks on group
Shuffle OFF	Shuffle OFF	Turn off shuffle

Appendix

■ Certification

● Bluetooth

The Bluetooth word mark and logo are registered trademarks of Bluetooth SIG, Inc. and any use of such marks by Clarion Co., Ltd. is under license.



● SiriusXM Satellite Radio (if equipped)

SiriusXM™ and all related marks and logos are trademarks of SiriusXM Radio Inc. All rights reserved.



● Pandora (if equipped)

Pandora, the Pandora logo, and other Pandora marks are trademarks or registered trademarks of Pandora Media, Inc., or its subsidiaries worldwide.

If you have any issues with the Pandora application on your mobile phone, please direct them to pandora-support@pandora.com.

P

● iPod

“Made for iPod” and “Made for iPhone” mean that an electronic accessory has been designed to connect specifically to iPod or iPhone respectively, and has been certified by the developer to meet Apple performance standards. Apple is not responsible for the operation of this device or its compliance with safety and regulatory standards. Please note that the use of this accessory with iPod or iPhone may affect wireless performance.

iPhone, iPod, iPod classic, iPod nano, iPod touch, and iTunes are trademarks of Apple Inc., registered in the U.S. and other countries.



● How to get the source code using the open source

This system implements software using the open source. For customers who would like to get the source code of the software, it is available by downloading it from the web site of Clarion Co., Ltd.

For details, refer to the following web site. <http://www.clarion.com/us/en/support/in->

dex.html

■ Certification for the Hands-free system

This device complies with Part 15 of FCC Rules. Operation is subject to the following two conditions: (1) this device may not cause harmful interference, and (2) this device must accept any interference received, including interference that may cause undesired operation.

This equipment complies with FCC radiation exposure limits set forth for an uncontrolled environment and meets the FCC radio frequency (RF) Exposure Guidelines in Supplement C to OET65. This equipment has very low levels of RF energy that it deemed to comply without maximum permissive exposure evaluation (MPE).

FCC CAUTION

Changes or modifications not expressly approved by the party responsible for compliance could void the user's authority to operate the equipment.

This transmitter must not be co-located or operated in conjunction with any other antenna or transmitter.

■ Certification for Mexico models

IFETEL RCPCLPF14-0253-A5

Clarion PF-3764

La operación de este equipo está sujeta a las siguientes dos condiciones:

(1) es posible que este equipo o dispositivo no cause interferencia perjudicial y
(2) este equipo o dispositivo debe aceptar cualquier interferencia, incluyendo la que pueda causar su operación no deseada.



S01731